

BEARING, SHAFTS, CLAMPS, COLLARS, HUBS & KEYS

Table of Contents

HUBS

Gear, Dial and Sprocket Assemblies - Tech Info.	2
Phase Adjustable Hub	3
Hubs - Quick To Lock	4
Gear, Sprocket and Dial Hubs	5 - 7
Dual Gear Hubs	8

CLAMPS

Split Hub Clamps	9 - 13
Shaft Clamp	14
Threaded Shaft Clamp	15
Squeeze Clamp	16

COLLARS

Set Screw Collars	17 - 18
-----------------------------	-----------

SHAFTS

Plastic Rod Stock	19
Threaded Stock	20
Case Hardened and Ground Shafts	21
Stainless Ground Shafts	22 - 26
Ultra Ground Shafting	27

WOODRUFF KEYS	28
--------------------------------	----

BEARINGS

Dyna-Speed Needle Roller Bearings	29
Ball Bearings	30 - 36
Angular Contact Ball Bearings	37
Oil-Less Bearings	38 - 41
Precision Bearings	42 - 43
Thermoplastic Bearings - Reference Chart	44
Thermoplastic Bearings	45 - 46
Journal Bearings	47 - 48
Composit Annular Bearings	49
Composit Spherical Bearings	50
Spherical Bearings	51
Thermoplastic Spherical Bearings	52
Thrust Bearings	53
Roller Thrust Bearings	54



GEAR, DIAL AND SPROCKET ASSEMBLIES

Technical Information

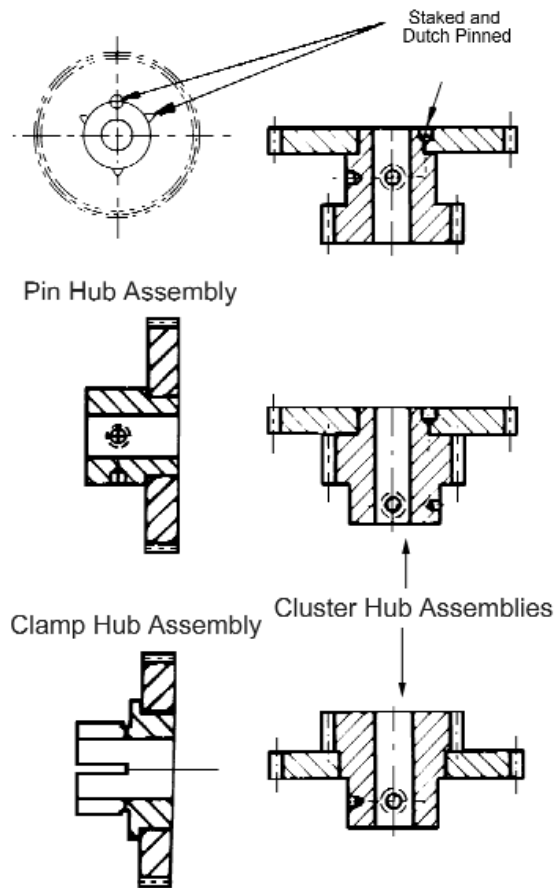

W.M. Berg has a wide selection of hub sizes and styles to select from. Our all stainless steel hubs are available in bore diameters ranging from 5/64" to 1 1/4".

See the following pages for pin hub, clamp hubs and dual hubs, see index for cluster gears. W.M. Berg assembles hubless gears, sprockets or dials to hubs for a nominal assembly charge. Contact our Customer Service Department for more information.

PHASE ADJUSTABLE HUB

BORE	TYPE	MATERIAL
.1200" TO .2498"	PIN HUB 360° ADJUSTABLE BI-DIRECTIONAL	303 STAINLESS STEEL

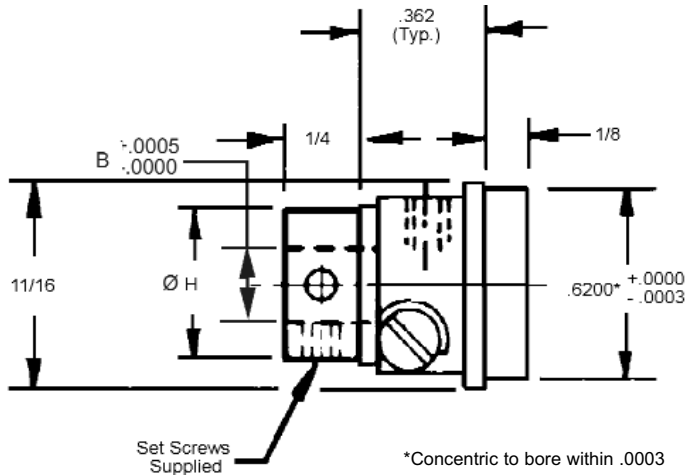

STOCK NO.	B BORE	ØH
PH6-4	.1200	5/16
PH6-1	.1248	5/16
PH6-2	.1873	3/8
PH6-3	.2498	1/2

BORE	TYPE	MATERIAL
.1200" TO .2498"	CLAMP HUB 360° ADJUSTABLE BI-DIRECTIONAL	303 STAINLESS STEEL

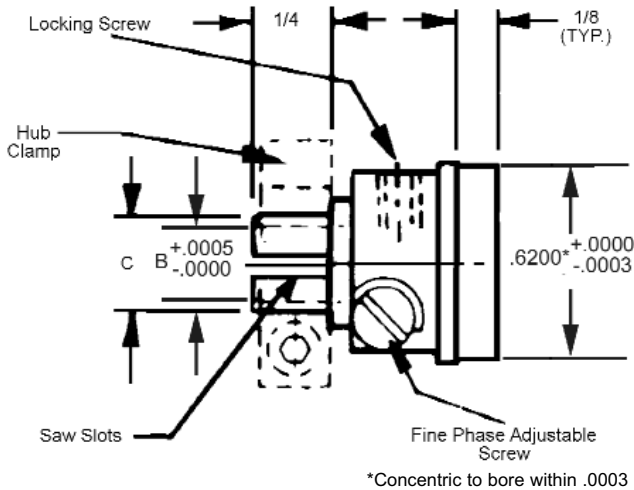

STOCK NO.	B BORE	C	HUB CLAMP NO. (ORDER SEPARATELY)
CH6-4	.1200	3/16	CG1-25
CH6-1	.1248	3/16	CG1-25
CH6-2	.1873	1/4	CG1-9
CH6-3	.2498	5/16	CG1-12

HUBS - QUICK TO LOCK

BORE	TYPE	MATERIAL
3/16" TO 3/4"	CLAMP HUB	303 STAINLESS STEEL

STOCK NO.	ØB	ØD	L	E	A	C	MAX. TRANSMISSIBLE		CONTACT PRESSURE		INSTALLATION TORQUE ON NUT IN. LBS	WT. OZ.
							TORQUE IN. LBS.	THRUST LBS.	ON HUB LBS./SQ.IN	ON SHAFT LBS./SQ.IN		
QH-3S	3/16	5/8	3/4	3/8	1/2	1/8	100	700	5200	6800	125	1/2
QH-4S	1/4	5/8	3/4	3/8	1/2	1/8	150	788	5200	5700	125	1/2
QH-5S	5/16	3/4	7/8	7/16	5/8	1/8	200	892	3700	3650	150	1
QH-6S	3/8	3/4	7/8	7/16	5/8	1/8	250	925	3700	3050	150	1
QH-8S	1/2	7/8	1	1/2	3/4	3/16	350	980	2700	2500	175	1 1/2
QH-10S	5/8	1	1 1/8	5/8	7/8	3/16	450	995	1800	1580	200	2
QH-11S	11/16	1 1/2	1 1/2	3/4	1 1/4	3/16	1800	3500	5000	5500	1200	8
QH-12S	3/4	1 1/2	1 1/2	3/4	1 1/4	3/16	1800	4000	5000	5000	1200	8

BORE	TYPE	MATERIAL
3/16" TO 3/4"	CLAMP HUB	TOOL STEEL

STOCK NO.	ØB	ØD	L	E	A	C	MAX. TRANSMISSIBLE		CONTACT PRESSURE		INSTALLATION TORQUE ON NUT IN. LBS	WT. OZ.
							TORQUE IN. LBS.	THRUST LBS.	ON HUB LBS./SQ.IN	ON SHAFT LBS./SQ.IN		
QH-3T	3/16	5/8	3/4	3/8	1/2	1/8	100	700	5200	6800	125	1/2
QH-4T	1/4	5/8	3/4	3/8	1/2	1/8	150	788	5200	5700	125	1/2
QH-5T	5/16	3/4	7/8	7/16	5/8	1/8	200	892	3700	3650	150	1
QH-6T	3/8	3/4	7/8	7/16	5/8	1/8	250	925	3700	3050	150	1
QH-8T	1/2	7/8	1	1/2	3/4	3/16	350	980	2700	2500	175	1 1/2
QH-10T	5/8	1	1 1/8	5/8	7/8	3/16	450	995	1800	1580	200	2
QH-11T	11/16	1 1/2	1 1/2	3/4	1 1/4	3/16	1800	3500	5000	5500	1200	8
QH-12T	3/4	1 1/2	1 1/2	3/4	1 1/4	3/16	1800	4000	5000	5000	1200	8

- Quick and easy installation - just tighten the nut
 - Positive release for removal or adjustment
 - Eliminates expensive machining operations such as cutting of keyways, turning of snap ring grooves, splines, shoulders and threads for lock nuts, drilling and pinning
 - Drastically relaxes shaft and hub tolerances, permitting the use of commercially finished shafting
 - Smaller diameter shafts (and bearings) may be used, offering equal strength and stiffness because of the rigidizing effect of quick-2-lock and because of the elimination of keyways
 - Infinite lateral and easy circumference positioning
 - Quick and easy removal
 - Excellent concentricity ØB to ØD within .002"
 - Greater shaft strength and stiffness
 - Unaffected by vibration and torque reversal
 - Available in metric shaft sizes 5mm through 16mm
- The "torque on nut" column represents values which are necessary to obtain the maximum transmissible torque/thrust.

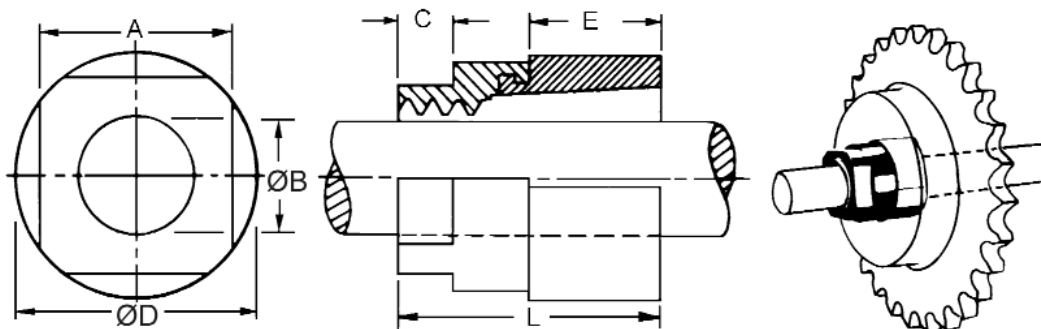

GEAR, SPROCKET AND DIAL HUBS

BORE				TYPE				MATERIAL																															
5/64" TO 1 1/4"				PIN HUB				303 STAINLESS STEEL																															
STOCK NO.	B +.0005 +.0000	A +.0005 +.0000	T	L	H	SPOT DRILL	SET SCREW	STOCK NO.	B +.0005 +.0000	A +.0005 +.0000	T	L	H	SPOT DRILL	SET SCREW																								
PH4-27 PH4-28	.0781	.3750	.062 .125	.22	7/16	#69	#2-56	PH1-20 PH1-62 PH4-62 PH4-63 PH2-7 PH2-5 PH2-23	.3748	.6875	.062 .093 .125 .187 .250 .375 .575	.50	1	#42	#8-32																								
PH4-29 PH4-30	.0900		.062 .125					PH1-24 PH1-64 PH4-64 PH4-65 PH1-27 PH1-28 PH1-36 PH2-29			.062 .093 .125 .187 .250 .375 .500 .575																												
PH4-31 PH4-32	.0937		.062 .125					PH1-30 PH1-31 PH1-32 PH1-33 PH1-34 PH2-35			1/8 3/16 1/4 3/8 1/2 .575																												
PH4-7 PH4-8	.1200		.062 .125					PH1-38 PH1-39 PH1-40 PH1-41 PH1-42 PH2-43			1/8 3/16 1/4 3/8 1/2 .575																												
PH4-1 PH1-3 PH4-2 PH2-12 PH2-1 PH2-10	.1248	.3750	.062 .093 .125 .187 .250 .575	.22	7/16	#69	#2-56	PH1-27 PH1-28 PH1-36 PH2-29	.4998	.6875	.062 .093 .125 .187 .250 .375 .500 .575	.50	1 1/4	#42	#8-32																								
PH4-33 PH4-34			.1562					.062 .125			PH1-30 PH1-31 PH1-32 PH1-33 PH1-34 PH2-35					1/8 3/16 1/4 3/8 1/2 .575																							
PH4-3 PH1-8 PH4-4 PH2-13 PH2-2 PH2-11			.1873					.3750			.062 .093 .125 .187 .250 .575					.22	7/16	#60	#4-40	PH1-38 PH1-39 PH1-40 PH1-41 PH1-42 PH2-43	.7500	1.374	1/8 3/16 1/4 3/8 1/2 .575	.75	1 1/2	#31	1/4-20												
PH4-35 PH4-36											.2405									.062 .125			PH1-46 PH1-47 PH1-48 PH1-49 PH1-50 PH2-51					1/8 3/16 1/4 3/8 1/2 .575											
PH4-5 PH1-13 PH4-6 PH2-14 PH2-3 PH2-15											.2498									.3750			.062 .093 .125 .187 .250 .575					.25	1/2	#50	#6-32	PH1-46 PH1-47 PH1-48 PH1-49 PH1-50 PH2-51	1.0000	1.374	1/8 3/16 1/4 3/8 1/2 .575	1.00	1 3/4	#22	3/8-16
PH2-4																							.3123									.250			PH1-54 PH1-55 PH1-56 PH1-57 PH1-58 PH2-59				
PH1-16 PH1-60 PH4-61 PH2-8 PH2-9 PH2-19	.3123	.6875		.062 .093 .125 .187 .250 .375 .575	.50	7/8	#42		#8-32	PH1-54 PH1-55 PH1-56 PH1-57 PH1-58 PH2-59		1.2500	1.374	1/8 3/16 1/4 3/8 1/2 .575	1.00								1 3/4									#22			3/8-16				
PH1-16 PH1-60 PH4-61 PH2-8 PH2-9 PH2-19				.3123						.6875				.062 .093 .125 .187 .250 .375 .575																									

* Diameters A & B are concentric within .0005.

- Fasten component to hub with epoxy cement or stake and dutch pin
- Assembly by Berg available.

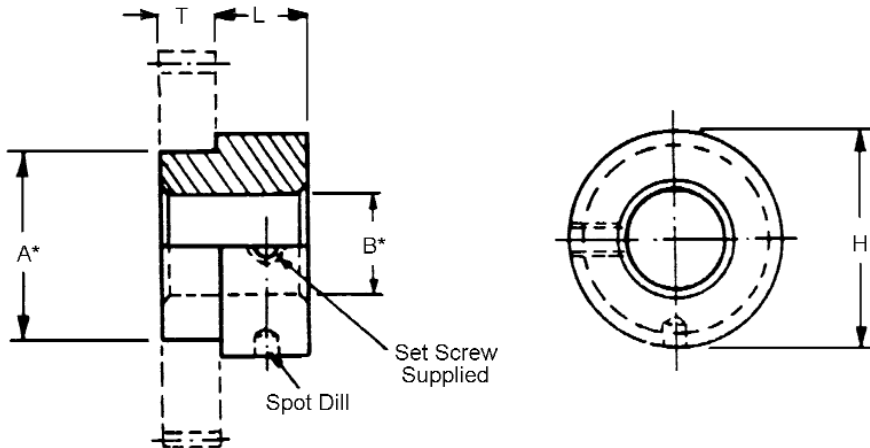

GEAR, SPROCKET AND DIAL HUBS

BORE	TYPE	MATERIAL
.0900 TO .2498	PIN HUB	303 STAINLESS STEEL

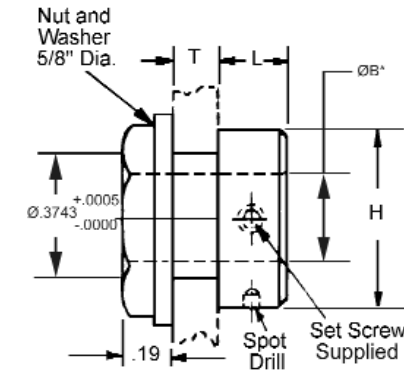

* Concentric within .0005

STOCK NO.	ØB +.0005 -.0000	T	H	L
PH4-19 PH4-20	.0900	.062 .125	7/16	.22
PH4-21 PH4-22	.0937	.062 .125		
PH4-15 PH4-16	.1200	.062 .125		
PH4-9 PH4-10	.1248	.062 .125		
PH4-23 PH4-24	.1562	.062 .125		
PH4-11 PH4-12	.1873	.062 .125		
PH4-25 PH4-26	.2405	.062 .125	1/2	.25
PH4-13 PH4-14	.2498	.062 .125		

BORE	TYPE	MATERIAL
.0900 TO .2498	CLAMP HUB	303 STAINLESS STEEL

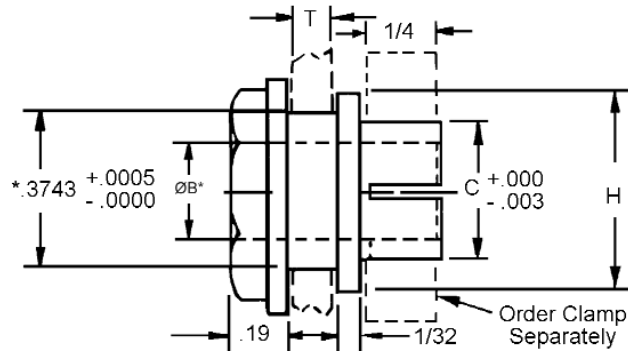

* Concentric within .0005

STOCK NO.	ØB +.0005 -.0000	T	H	C	CLAMP STOCK NO.
CH2-19 CH2-20	.0900	.062 .125	7/16	.188	CG1-5
CH2-21 CH2-22	.0937	.062 .125			
CH2-15 CH2-16	.1200	.062 .125			
CH2-9 CH2-10	.1248	.062 .125			
CH2-23 CH2-24	.1562	.062 .125			
CH2-11 CH2-12	.1873	.062 .125			
CH2-25 CH2-26	.2405	.062 .125	1/2	.312	CG1-12
CH2-13 CH2-14	.2498	.062 .125			

GEAR, SPROCKET AND DIAL HUBS

BORE	TYPE	MATERIAL
5/64" TO 1/2"	CLAMP HUB	303 STAINLESS STEEL

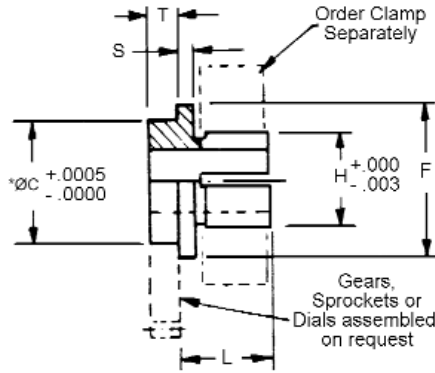
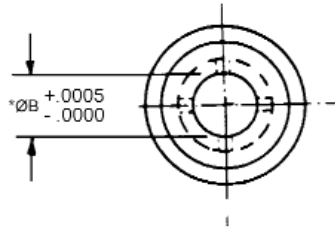

* Concentric within .0005

STOCK NO.	B	C	T	L	H	F	S	CLAMP STOCK NO.
CH2-27 CH2-28	.0781	.3750	.062 .125	.281	3/16	7/16	.031	CG1-5
CH2-29 CH2-30	.0900	.3750	.062 .125	.281	3/16	7/16	.031	CG1-5
CH2-31 CH2-32	.0937	.3750	.062 .125	.281	3/16	7/16	.031	CG1-5
CH2-7 CH2-8	.1200	.3750	.062 .125	.281	3/16	7/16	.031	CG1-5
CH2-1 CH1-3 CH2-2 CH1-35	.1248	.3750	.062 .093 .125 .187	.281 .250 .281 .281	3/16	7/16	.031 .046 .031 .046	CG1-5
CH2-33 CH2-34	.1562	.3750	.062 .125	.281	1/4	7/16	.031	CG1-9
CH2-3 CH1-7 CH2-4 CH1-40	.1873	.3750	.062 .093 .125 .187	.281 .313 .281 .281	1/4	7/16	.031 .046 .031 .046	CG1-9
CH2-35 CH2-36	.2405	.3750	.062 .125	.281	5/16	1/2	.031	CG1-12
CH2-5 CH1-11 CH2-6 CH1-43	.2498	.3750	.062 .093 .125 .187	.281 .313 .281 .344	5/16	1/2 7/16 1/2 7/16	.031 .046 .031 .046	CG1-12
CH1-13 CH1-52 CH2-60 CH2-61	.3123	.6875	.062 .093 .125 .187	.375	3/8	7/8	.062	CG1-15
CH1-16 CH1-54 CH2-62 CH2-63	.3748	.6875	.062 .093 .125 .187	.375	7/16	1	.062	CG1-18
CH1-19 CH1-56 CH2-64 CH2-65 CH1-22 CH1-23	.4998	.6875	.062 .093 .125 .187 .250 .375	.375	9/16	1 1/4	.062	CG1-19

DUAL GEAR HUBS

BORE	TYPE	MATERIAL
1/8" TO 1/2"	PIN HUB	303 STAINLESS STEEL

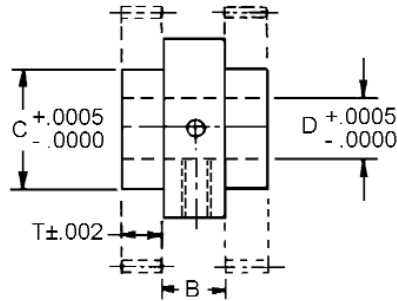
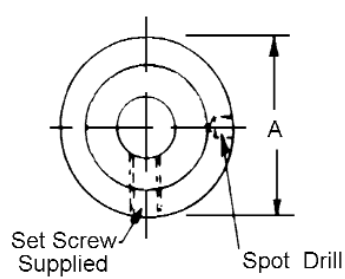

STOCK NO.	D	C	T	A	B
PH3-1	.1248	.3750	1/8	7/16	1/4
PH3-2	.1873	.3750	1/8	7/16	1/4
PH3-3	.2498	.3750	1/8	1/2	1/4
PH3-4	.3123	.3750	1/8	1/2	1/4
PH3-5	.3748	.6872	3/8	1	1/2
PH3-6	.4998	.6872	1/4	1 1/4	1/2

- Assembly available
- Gears are triple staked and dutch pinned at assembly
- Components may also be assembled to hubs with epoxy cement
- Order gears separately

SPLIT HUB CLAMPS

BORE	TYPE	MATERIAL
.103" TO .562"	COMPACT CLAMP DESIGN	303 STAINLESS STEEL OR ALUMINUM ANODIZED

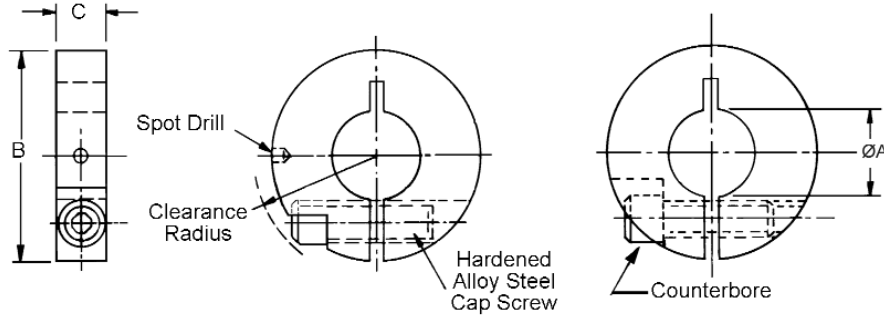

Note: Some sizes may be full or semi-counterbored or step cut at manufacturer's option.

STAINLESS STEEL STOCK NO.	ANODIZED ALUMINUM STOCK NO.	ØA DIA.	B DIA.	C	CLEAR. RADIUS	CAP SCREW THREAD	SPOT DRILL DIA.	SPLIT HUB INSIDE DIA. (Ref.)
CG1-1	CG1-1-A	.103	1/2	5/32	5/16	#3-48	1/16	-
CG1-2	CG1-2-A	.125	1/2	5/32	5/16	#3-48	1/16	-
CG1-20	CG1-20-A	.125	9/16	5/32	3/8	#2-56	-	-
CG1-21	CG1-21-A	.125	5/8	5/32	3/8	#2-56	-	-
CG1-3	CG1-3-A	.141	1/2	5/32	5/16	#3-48	1/16	-
CG1-22	CG1-22-A	.188	9/16	1/8	3/8	#1-72	-	-
CG1-23	CG1-23-A	.188	9/16	5/32	3/8	#2-56	-	5/64
CG1-4	CG1-24-A	.188	5/8	5/32	11/32	#2-56	-	TO
CG1-5	-	.188	5/8	3/16	3/8	#4-40	1/16	1/8
CG1-25	CG1-25-A	.188	7/8	1/4	33/64	#6-32	-	-
CG1-6	-	.219	5/8	5/32	11/32	#2-56	1/16	-
CG1-26	CG1-26-A	.250	9/16	1/8	3/8	#1-72	-	-
CG1-27	CG1-27-A	.250	9/16	5/32	3/8	#2-56	-	5/32
CG1-28	CG1-28-A	.250	5/8	5/32	3/8	#2-56	-	& 3/16
CG1-8	CG1-8-A	.250	7/8	3/16	31/64	#4-40	1/8	-
CG1-9	CG1-9-A	.250	7/8	1/4	33/64	#6-32	-	-
CG1-10	-	.281	7/8	1/4	33/64	#6-32	1/8	-
CG1-11	-	.312	7/8	3/16	31/64	#4-40	1/8	.2405
CG1-12	CG1-12-A	.312	7/8	1/4	33/64	#6-32	-	& 1/4
CG1-14	CG1-14-A	.375	1 1/8	1/4	21/32	#8-32	3/16	-
CG1-15	CG1-15-A	.375	1 1/4	5/16	11/16	#8-32	-	5/16
CG1-31	-	.375	1 1/4	5/16	5/8	#8-32	-	-
CG1-17	CG1-17-A	.437	1 1/8	1/4	21/32	#8-32	3/16	-
CG1-18	CG1-18-A	.437	1 1/4	5/16	11/16	#8-32	-	3/8
CG1-32	-	.437	1 1/4	5/16	5/8	#8-32	-	-
CG1-19	CG1-19-A	.562	1 1/4	5/16	11/16	#8-32	-	1/2
CG1-33	-	.562	1 1/4	5/16	5/8	#8-32	-	-

Special clamps are available on request.

SPLIT HUB CLAMPS

SHAFT SIZE	MATERIAL
1/8" TO 3/8"	STAINLESS STEEL AND MILD STEEL

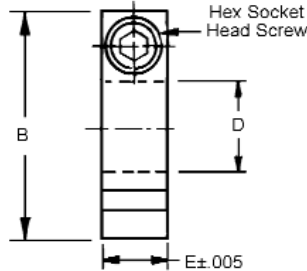
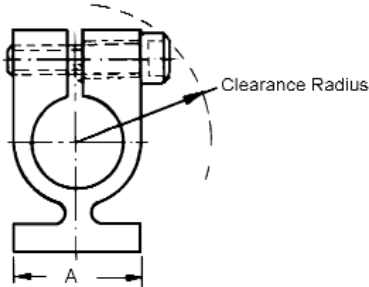

STOCK NO.	MATERIAL	D	A	B	CLEAR. RADIUS	E	SCREW	FINISH	SHAFT SIZE
CG3-1	416 STAINLESS STEEL	.188	.312	.687	7/16	.240	# 6-32	CLEAR PASS.	1/8
CG3-2	416 STAINLESS STEEL					.240	# 6-32	BLACK PASS	
CG3-7	303 STAINLESS STEEL					.250	# 6-32	CLEAR PASS.	
CG3-28	MILD STEEL					.140	# 2-56	CAD.PLATE	
CG3-3	416 STAINLESS STEEL	.251	.378	.812	33/64	.240	# 6-32	CLEAR PASS.	3/16
CG3-4	416 STAINLESS STEEL					.240	# 6-32	BLACK PASS	
CG3-9	303 STAINLESS STEEL					.250	# 6-32	CLEAR PASS.	
CG3-30	MILD STEEL					.140	# 2-56	CAD. PLATE	
CG3-5	416 STAINLESS STEEL	.313	.437	.812	9/16	.240	# 6-32	CLEAR PASS.	1/4
CG3-6	416 STAINLESS STEEL					.240	# 6-32	BLACK PASS	
CG3-11	303 STAINLESS STEEL					.250	# 6-32	CLEAR PASS.	
CG3-32	MILD STEEL					.140	# 2-56	CAD.PLATE	
CG3-13	303 STAINLESS STEEL	.376	.500	.875	9/16	.250	# 6-32	CLEAR PASS.	5/16
CG3-14	MILD STEEL					.250	# 6-32	CAD.PLATE	
CG3-34	MILD STEEL					.140	# 2-56	CAD.PLATE	
CG3-15	303 STAINLESS STEEL	.438	.625	1.032	43/64	.250	# 6-32	CLEAR PASS.	3/8
CG3-16	MILD STEEL					.250	# 6-32	CAD. PLATE	
CG3-36	MILD STEEL					.140	# 2-56	CAD. PLATE	

SHAFT SIZE	TYPE	MATERIAL
1/8" TO 3/8"	BALANCED CLAMP	STAINLESS STEEL AND MILD STEEL

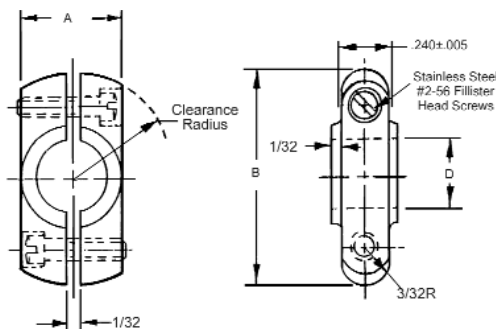

STOCK NO.	D	A	B	TYPE CLEAR. RADIUS	SPLIT HUB OF BALANCE	INSIDE DIA. (REF.)
CG2-1	.188	.312	.718	3/8	DYNAMICALLY BALANCED	1/8
CG2-3	.251	.374	.750	13/32		3/16
CG2-5	.313	.436	.875	15/32		1/4
CG2-2	.188	.312	.718	3/8	AS CAST	1/8
CG2-4	.251	.374	.750	13/32		3/16
CG2-6	.313	.436	.875	15/32		1/4

SPLIT HUB CLAMPS

SHAFT SIZE	TYPE	MATERIAL
1/8" TO 3/8"	BALANCED CLAMP	416 STAINLESS STEEL AND 303 STAINLESS STEEL

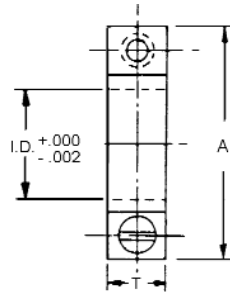
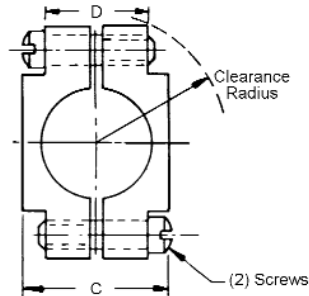

STOCK NO.	MATERIAL	INSIDE DIA.	T	A	C	D	SCREW	SPLIT HUB CLEARANCE RADIUS	INSIDE DIA. (Ref.)
CG2-7	416 STAINLESS STEEL	.187	.156	.500	.286	.176	#2-56	9/32	1/8
CG2-8		.250	.187	.590	.350	.235	#3-48	11/32	3/16
CG2-9		.312	.187	.687	.420	.286	#4-40	13/32	1/4
CG2-10		.375	.187	.781	.510	.336	#4-40	15/32	5/16
CG2-11		.437	.250	.890	.636	.365	#6-32	35/64	3/8
CG2-27	303 STAINLESS STEEL	.187	.156	.500	.286	.176	#2-56	9/32	1/8
CG2-28		.250	.187	.590	.350	.235	#3-48	11/32	3/16
CG2-29		.312	.187	.687	.420	.286	#4-40	13/32	1/4
CG2-30		.375	.187	.781	.510	.336	#4-40	15/32	5/16
CG2-31		.437	.250	.890	.636	.365	#6-32	35/64	3/8

SHAFT SIZE	TYPE	MATERIAL
1/8" TO 1/4"	BALANCED CLAMP	303 STAINLESS STEEL OR 2024 ALUMINUM ANODIZED

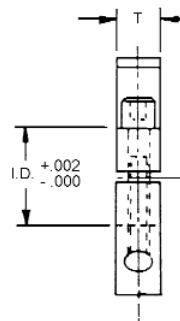
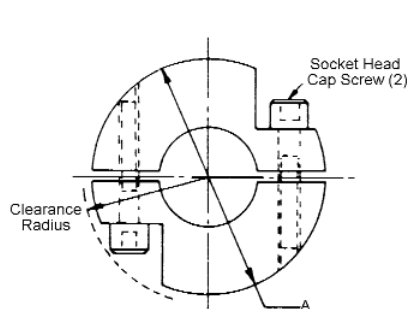

STOCK NO.	MATERIAL	INSIDE DIA.	T	A	SCREW	SPLIT HUB CLEARANCE RADIUS	SPLIT HUB INSIDE DIA. (REF.)
CG2-12-S	STAINLESS STEEL	.125					-
CG2-12-A	ALUMINUM	.125					-
CG2-13-S	STAINLESS STEEL	.188	.156	.562	#2-56	25/64	1/8
CG2-13-A	ALUMINUM	.188					1/8
CG2-15-S	STAINLESS STEEL	.250					3/16
CG2-15-A	ALUMINUM	.250					3/16
CG2-14-S	STAINLESS STEEL	.188					1/8
CG2-14-A	ALUMINUM	.188					1/8
CG2-16-S	STAINLESS STEEL	.250					3/16
CG2-16-A	ALUMINUM	.250	.250	.875	#6-32	33/64	3/16
CG2-17-S	STAINLESS STEEL	.313					1/4
CG2-17-A	ALUMINUM	.313					1/4

SPLIT HUB CLAMPS

SHAFT SIZE	TYPE	MATERIAL
1/8" TO 1/2"	SCREW TYPE CLAMP	303 STAINLESS STEEL OR 2024 ALUMINUM ANODIZED

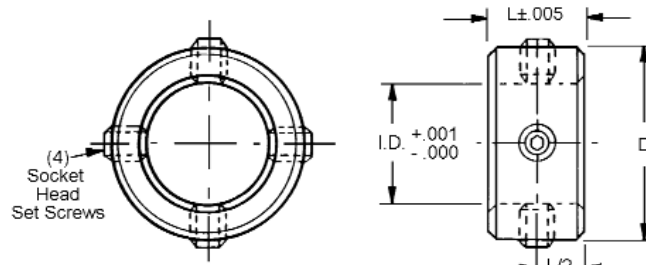

STAINLESS STEEL STOCK NO.	ALUMINUM STOCK NO.	INSIDE DIA.	D	L	SET SCREW	SPLIT HUB INSIDE DIA. (Ref.)
CS-36	-	.0995	.312	.125	#2-56	-
CS-28	CS-32	.1255	.375	.250	#4-40	-
CS-29	CS-33	.1880	.375	.250	#4-40	1/8
CS-30	CS-34	.2505	.500	.250	#6-32	3/16
CS-31	CS-35	.3130	.500	.250	#6-32	1/4
CS-40	CS-43	.3750	.750	.312	#10-32	5/16
CS-41	CS-44	.4370	.750	.312	#10-32	3/8
CS-42	CS-45	.5620	.875	.312	#10-32	1/2



SHAFT SIZE	TYPE	MATERIAL
1/8" TO 3/16"	SCREW TYPE CLAMP	416 STAINLESS STEEL

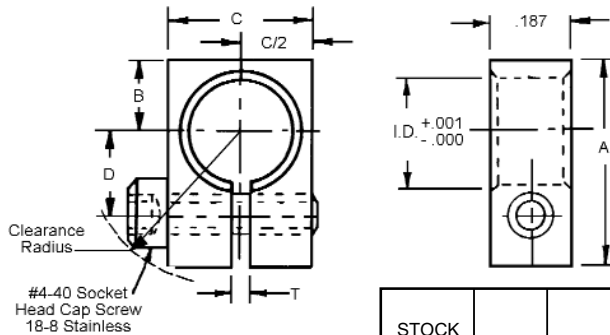

STOCK NO.	I.D.	A	C	D	B	T	CLEAR. RADIUS	SPLIT HUB INSIDE DIA. (Ref.)
CG4-1	.125	23/64	.218	.133	.109	.031	21/64	-
CG4-2	.187	27/64	.281	.165	.141	.040	25/64	1/8
CG4-3	.250	31/64	.344	.196	.172	.040	7/16	3/16

SPLIT HUB CLAMPS

SHAFT SIZE	TYPE	MATERIAL
1/8" TO 3/8"	TYPE I AND TYPE II	303 STAINLESS STEEL, MILD STEEL CADMIUM PLATED OR 416 STAINLESS STEEL RC 38-45

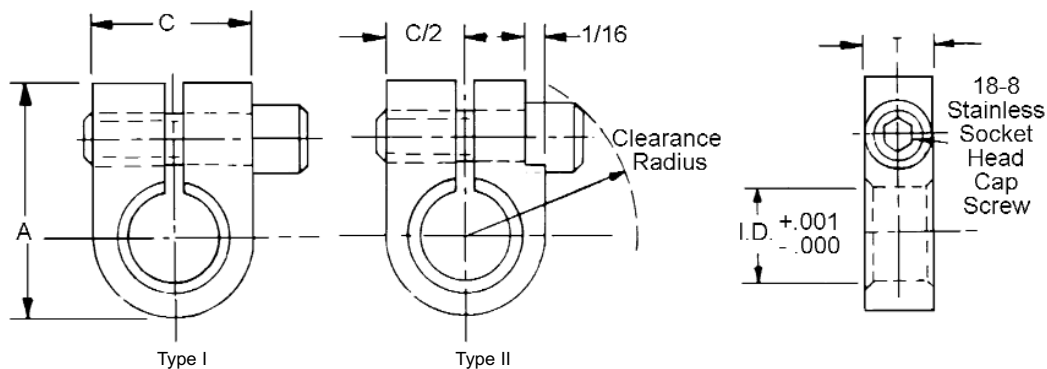

TYPE I								
STOCK NO.	MATERIAL	INSIDE DIA.	C	A	T	SCREW THREAD	SPLIT HUB CLEARANCE RADIUS	INSIDE DIA. (Ref.)
CG5-24	MILD STEEL	.188	.312	.468	.140	#2-56	11/32	1/8
CG5-25	MILD STEEL	.251	.375	.500	.140	#2-56	25/64	3/16
CG5-26	MILD STEEL	.313	.437	.593	.140	#2-56	7/16	1/4
CG5-27	MILD STEEL	.376	.500	.656	.140	#2-56	15/32	5/16
CG5-28	MILD STEEL	.438	.625	.781	.140	#2-56	9/16	3/8
CG5-14	MILD STEEL	.188	.312	.468	.250	#6-32	27/64	1/8
CG5-15	MILD STEEL	.251	.375	.562	.250	#6-32	1/2	3/16
CG5-16	MILD STEEL	.313	.437	.593	.250	#6-32	33/64	1/4
CG5-17	MILD STEEL	.376	.500	.656	.250	#6-32	9/16	5/16
CG5-18	MILD STEEL	.438	.625	.781	.250	#6-32	41/64	3/8
CG5-29	303	.188	.312	.468	.250	#6-32	27/64	1/8
CG5-30	303	.251	.375	.562	.250	#6-32	1/2	3/16
CG5-31	303	.313	.437	.593	.250	#6-32	33/64	1/4
CG5-32	303	.376	.500	.656	.250	#6-32	9/16	5/16
CG5-33	303	.438	.625	.781	.250	#6-32	41/64	3/8
CG5-34	416	.188	.312	.468	.250	#6-32	27/64	1/8
CG5-35	416	.251	.375	.562	.250	#6-32	1/2	3/16
CG5-36	416	.313	.437	.593	.250	#6-32	33/64	1/4
CG5-37	416	.376	.500	.656	.250	#6-32	9/16	5/16
CG5-38	416	.438	.625	.781	.250	#6-32	41/64	3/8

TYPE II								
STOCK NO.	MATERIAL	INSIDE DIA.	C	A	T	SCREW THREAD	SPLIT HUB CLEARANCE RADIUS	INSIDE DIA. (Ref.)
CG5-19	MILD STEEL	.188	.312	.468	.140	#2-56	5/16	1/8
CG5-20	MILD STEEL	.251	.375	.500	.140	#2-56	23/64	3/16
CG5-21	MILD STEEL	.313	.437	.593	.140	#2-56	25/64	1/4
CG5-22	MILD STEEL	.376	.500	.656	.140	#2-56	7/16	5/16
CG5-23	MILD STEEL	.438	.625	.781	.140	#2-56	33/64	3/8
CG5-9	MILD STEEL	.188	.312	.468	.250	#6-32	3/8	1/8
CG5-10	MILD STEEL	.251	.375	.562	.250	#6-32	29/64	3/16
CG5-11	MILD STEEL	.313	.437	.593	.250	#6-32	15/32	1/4
CG5-12	MILD STEEL	.376	.500	.656	.250	#6-32	33/64	5/16
CG5-13	MILD STEEL	.438	.625	.781	.250	#6-32	19/32	3/8
CG5-39	303	.188	.312	.468	.250	#6-32	3/8	1/8
CG5-40	303	.251	.375	.562	.250	#6-32	29/64	3/16
CG5-41	303	.313	.437	.593	.250	#6-32	15/32	1/4
CG5-42	303	.376	.500	.656	.250	#6-32	33/64	5/16
CG5-43	303	.438	.625	.781	.250	#6-32	19/32	3/8
CG5-44	416	.188	.312	.468	.250	#6-32	3/8	1/8
CG5-45	416	.251	.375	.562	.250	#6-32	29/64	3/16
CG5-46	416	.313	.437	.593	.250	#6-32	15/32	1/4
CG5-47	416	.376	.500	.656	.250	#6-32	33/64	5/16
CG5-48	416	.438	.625	.781	.250	#6-32	19/32	3/8

SHAFT CLAMP

SHAFT SIZE	MATERIAL
3/32" TO 3/16"	416 STAINLESS STEEL

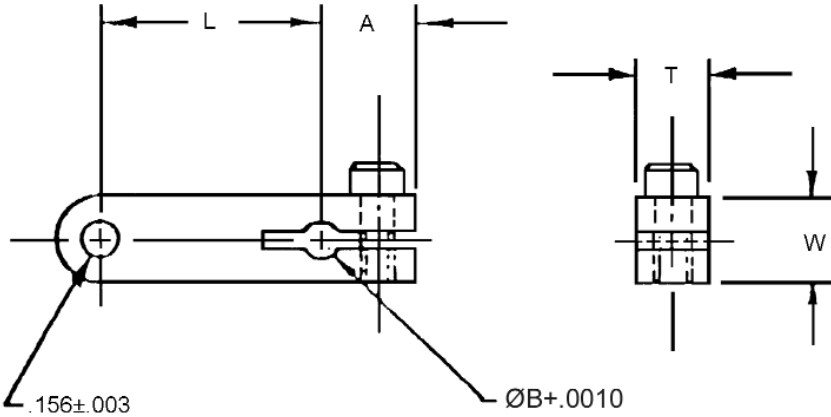

STOCK NO	A	ØB	L	T	W
CG7-1	.250	.0938	.625	.190	.250
CG7-2	.250	.1250	.625	.190	.250
CG7-3	.250	.1875	.625	.190	.312



THREADED SHAFT CLAMP

THREAD SIZE	MATERIAL
1/4 X 20 TO 3/4 X10	12L14 STEEL

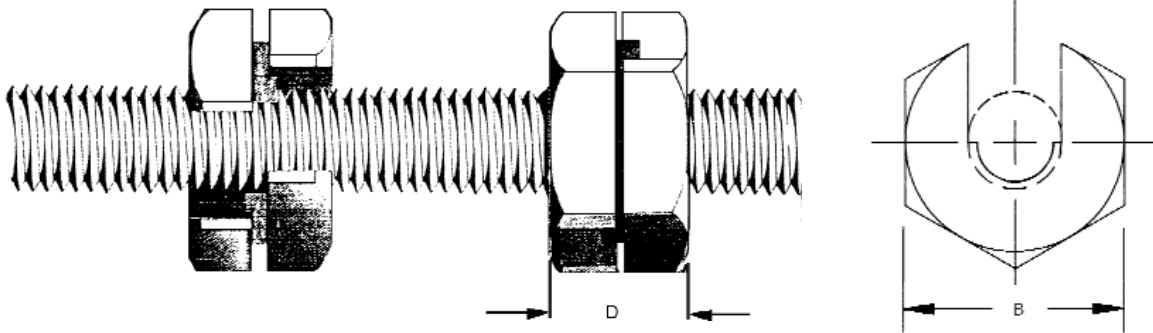

STOCK NO.	THREAD	B	D (APPROX)	MAX.* LOAD (lbs.)
TSC-25	1/4 x 20	.63	.38	650
TSC-37	3/8 x 16	.88	.47	2,000
TSC-50	1/2 x 13	1.06	.63	4,000
TSC-62	5/8 x 11	1.31	.66	5,000
TSC-75	3/4 x 10	1.63	.83	8,000

* Or as limited by rod.



SQUEEZE CLAMP

SHAFT SIZE	MATERIAL
3/16" TO 9/16"	NUT - STAINLESS STEEL BUSHING - BRONZE

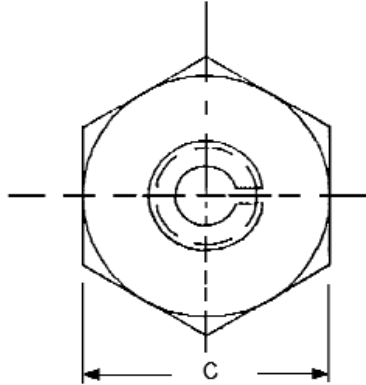
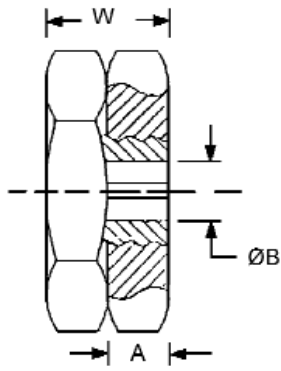

STOCK NO.	ØB	A	W	C	REF. SHAFT SIZE	SPLIT HUB INSIDE DIA. (Ref.)
SCL-1	.187	.125	.250	5/8	3/16	5/64 - 1/8
SCL-2	.250	.125	.250	5/8	1/4	5/32 - 3/16
SCL-3	.312	.125	.250	3/4	5/16	.2405 - 1/4
SCL-4	.375	.125	.250	3/4	3/8	5/16
SCL-5	.437	.155	.310	7/8	7/16	3/8
SCL-6	.562	.155	.310	7/8	9/16	1/2

- High clamping force
- Clamp directly to shafting or over a split hub

SET SCREW COLLARS

BORE SIZE	MATERIAL
5/64" TO 1 1/4" PRECISION BORE	303 STAINLESS STEEL

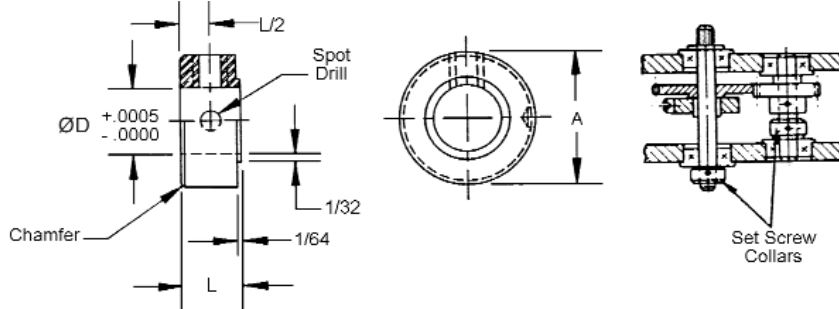

STOCK NO.	SHAFT SIZE	ØD	L	A	SPOT DRILL	SET SCREW
CS-1	5/64	.0779	.120	7/32	#78 (.016)	#0-80
CS-2	3/32	.0935	.120	1/4	#78 (.016)	#0-80
CS-3	1/8	.1248	.180	5/16	#69 (.028)	#2-56
CS-4	5/32	.1560	.180	5/16	#69 (.028)	#2-56
CS-5	3/16	.1873	.220	3/8	#60 (.040)	#4-40
CS-6	.2405	.2405	.250	1/2	#50 (.070)	#6-32
CS-7	1/4	.2498	.250	1/2	#50 (.070)	#6-32
CS-8	5/16	.3123	.250	1/2	#50 (.070)	#6-32
CS-9	3/8	.3748	.375	3/4	#31 (.120)	#10-24
CS-10	1/2	.4998	.437	1	#25 (.149)	1/4-20
CS-11	5/8	.6248	.500	1 1/4	#25 (.149)	1/4-20
CS-12	3/4	.7498	.562	1 1/2	#22 (.157)	3/8-16
CS-13	1	.9998	.625	2	#22 (.157)	3/8-16
CS-14	1 1/4	1.2498	.750	2 1/4	#22 (.157)	3/8-16

- No shim spacers required
- Used to pre-load bearing

BORE SIZE	MATERIAL
1/8" TO 1 1/4" COMMERCIAL BORE	COLD ROLLED STEEL ZINC PLATED

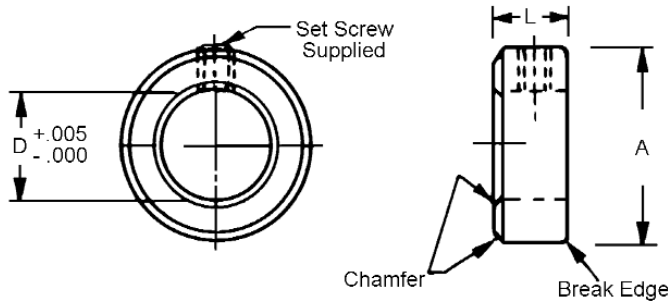

STOCK NO.	D	A	L	SET SCREW
CS-50	.125	3/8	1/4	#6
CS-51	.188	7/16	1/4	#8
CS-52	.250	1/2	9/32	#10
CS-53	.313	5/8	5/16	#10
CS-54	.375	3/4	3/8	1/4
CS-55	.500	1	7/16	1/4
CS-56	.625	1 1/8	1/2	5/16
CS-57	.750	1 1/4	9/16	5/16
CS-58	1.000	1 5/8	5/8	5/16
CS-59	1.250	2	11/16	3/8

SET SCREW COLLARS

BORE SIZE	MATERIAL
5/64" TO 1/2" PRECISION BORE	303 STAINLESS STEEL

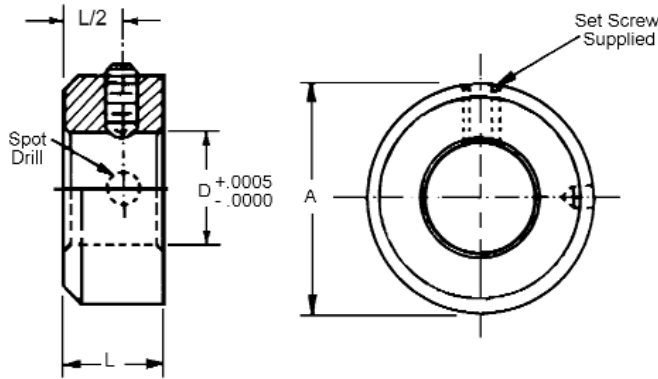

STOCK NO.	SHAFT SIZE	D	L	A	SPOT DRILL	SET SCREW
CS-26	5/64	.0779	.120	7/32	#78 (.016)	#0-80
CS-27	3/32	.0935	.120	1/4	#78 (.016)	#0-80
CS-23	.1200	.1200	.180	5/16	#69 (.028)	#2-56
CS-20	1/8	.1248	.180	5/16	#69 (.028)	#2-56
CS-24	5/32	.1560	.180	5/16	#69 (.028)	#2-56
CS-21	3/16	.1873	.220	3/8	#60 (.040)	#4-40
CS-25	.2405	.2405	.250	1/2	#50 (.070)	#6-32
CS-22	1/4	.2498	.250	1/2	#50 (.070)	#6-32
CS-37	5/16	.3123	.280	9/16	#50 (.070)	#6-32
CS-38	3/8	.3748	.375	3/4	#31 (.120)	#10-32
CS-39	1/2	.4998	.500	1	#25 (.149)	1/4-20

BORE SIZE	MATERIAL
1/8" TO 1/2" COMMERCIAL BORE	303 STAINLESS STEEL OR 2024T-4 ALUMINUM ANODIZED

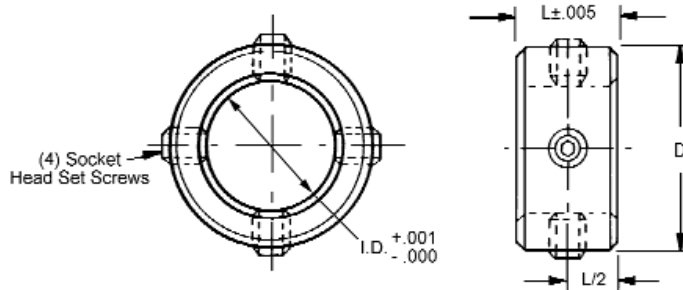

STAINLESS STEEL STOCK NO.	ALUMINUM STOCK NO.	SHAFT SIZE	I.D.	D	L	SET SCREW
CS-28	CS-32	1/8	.1255	.375	.250	#4-40
CS-29	CS-33	3/16	.1880	.375	.250	#4-40
CS-30	CS-34	1/4	.2505	.500	.250	#6-32
CS-31	CS-35	5/16	.3130	.500	.250	#6-32
CS-40	CS-43	3/8	.3750	.750	.312	#10-32
CS-41	CS-44	7/16	.4370	.750	.312	#10-32
CS-46	CS-47	1/2	.5000	.875	.312	#10-32

PLASTIC ROD STOCK

DIAMETER	MATERIAL
1/16" TO 3"	NYLON 101 OR DELRIN

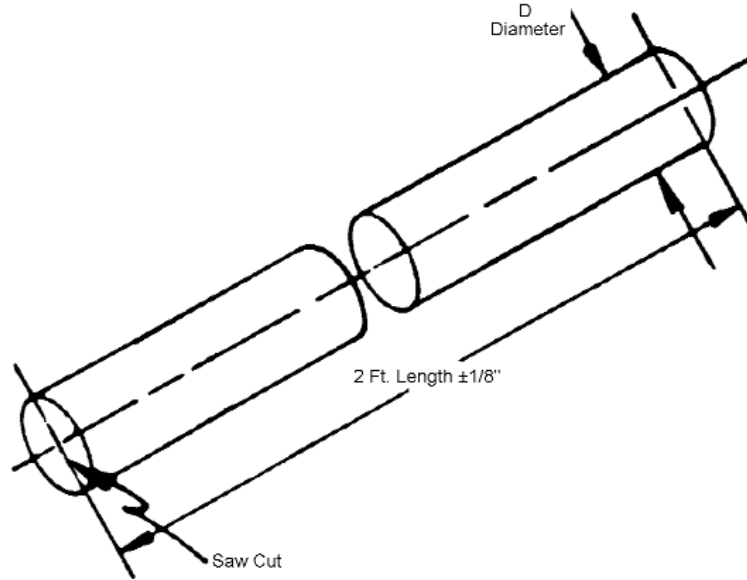

NYLON 101 STOCK NO.	DELRIN 500 STOCK NO.	D
PR-N-1	-	1/16
PR-N-51	-	3/32
PR-N-2	-	1/8
PR-N-3	PR-D-3	3/16
PR-N-4	PR-D-4	1/4
PR-N-6	PR-D-6	3/8
PR-N-8	PR-D-8	1/2
PR-N-10	PR-D-10	5/8
PR-N-12	PR-D-12	3/4
PR-N-16	PR-D-16	1
PR-N-20	PR-D-20	1 1/4
PR-N-24	PR-D-24	1 1/2
PR-N-28	PR-D-28	1 3/4
PR-N-32	PR-D-32	2
PR-N-40	PR-D-40	2 1/2
PR-N-48	PR-D-48	3

THREADED STOCK

THREAD	MATERIAL
#2-56 TO 1-14	18-8 STAINLESS STEEL

STOCK NO.	THREAD SIZE	LENGTH	DIA.	THREAD PITCH
T1-1	#2-56	12	.086	.018
T1-2	#4-40	12	.112	.025
T1-23	#4-40	24	.112	.025
T1-3	#6-32	12	.138	.031
T1-24	#6-32	24	.138	.031
T1-4	#8-32	12	.164	.031
T1-25	#8-32	24	.164	.031
T1-20	#10-24	16	.190	.042
T1-5	#10-24	24	.190	.042
T1-21	#10-32	16	.190	.031
T1-6	#10-32	24	.190	.031
T1-7	1/4-20	24	1/4	.050
T1-8	1/4-28	24	1/4	.036
T1-9	5/16-18	24	5/16	.055
T1-26	5/16-24	24	5/16	.042
T1-10	3/8-16	24	3/8	.062
T1-27	3/8-24	24	3/8	.042
T1-22	3/8-32	24	3/8	.031
T1-12	1/2-13	36	1/2	.077
T1-13	1/2-20	36	1/2	.050
T1-14	5/8-11	36	5/8	.091
T1-15	5/8-18	36	5/8	.056
T1-16	3/4-10	36	3/4	.100
T1-17	3/4-16	36	3/4	.062
T1-18	1-8	36	1	.125
T1-19	1-14	36	1	.071

THREAD	MATERIAL
#4-40 TO 1/2-13	MOLDED NYLON

STOCK NO.	THREAD SIZE	LENGTH	DIA.	THREAD PITCH
T2-1	#4-40	24	.112	.025
T2-2	#6-32	24	.138	.031
T2-3	#8-32	24	.164	.031
T2-4	#10-24	24	.190	.042
T2-5	#10-32	24	.190	.031
T2-6	1/4 - 20	24	1/4	.050
T2-7	5/16 - 18	24	5/16	.055
T2-8	3/8 - 16	24	3/8	.062
T2-9	1/2 - 13	24	1/2	.077

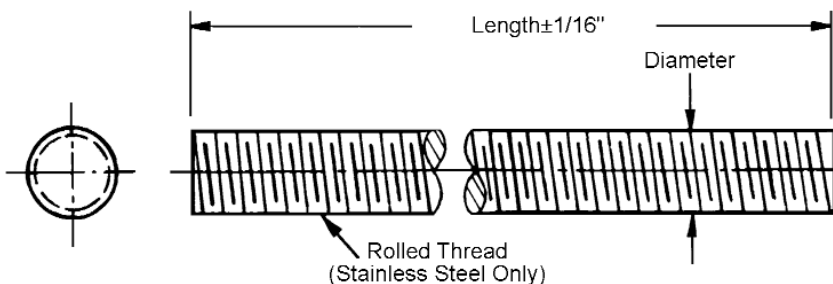

Special sizes and lengths are available on request. See index for threaded studs.
Straightness: .001 in/in

CASE HARDENED AND GROUND SHAFTS

DIAMETER	MATERIAL
1/4" TO 2"	C1060 STEEL HARDENED C60-65 OR 440 STAINLESS STEEL HARDENED C50-55

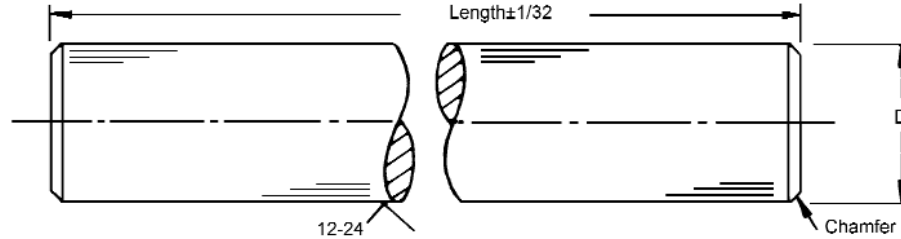

C1060 STEEL STOCK NO. (36" long)	C1060 STEEL STOCK NO. (12" long)	440 STAINLESS STEEL STOCK NO. (36" long)	NOM. DIA.	D DIAMETER	MAX. LENGTH AVAILABLE TO ORDER
LMS-4-36	-	-	1/4	.2490-.0005	8 ft.
LMS-5-36	-	-		.2495-.0005	
LMS-6-36	-	-	3/8	.3740-.0005	11 ft.
LMS-7-36	-	-		.3745-.0005	
LMS-46-36	LMS-46-12	-		.3750-.0005	
LMS-8-36	-	LMT-8-36	1/2	.4990-.0005	11 ft.
LMS-9-36	-	LMT-9-36		.4995-.0005	
LMS-48-36	LMS-48-12	-		.5000-.0005	
LMS-50-36	LMS-50-12	-	5/8	.6250-.0005	11 ft.
LMS-12-36	-	LMT-12-36	3/4	.7490-.0005	11 ft.
LMS-13-36	-	LMT-13-36		.7495-.0005	
LMS-52-36	LMS-52-12	-		.7500-.0005	
LMS-16-36	-	LMT-16-36	1	.9990-.0005	12 ft.
LMS-17-36	-	LMT-17-36		.9995-.0005	
LMS-56-36	LMS-56-12	-		1.0000-.0005	
LMS-20-36	-	-	1 1/4	1.2490-.0005	11 ft.
LMS-21-36	-	-		1.2495-.0005	
LMS-60-36	LMS-60-12	-		1.2500-.0005	
LMS-24-36	-	-	1 1/2	1.4989-.0005	11 ft.
LMS-25-36	-	-		1.4994-.0005	
LMS-64-36	LMS-64-12	-		1.5000-.0005	
LMS-32-36	-	-	2	1.9987-.0005	11 ft.
LMS-33-36	-	-		1.9994-.0007	
LMS-72-36	LMS-72-12	-		2.0000-.0005	

Straightness

LMS-4, LMS-5 best efforts basis

LMS-6 to LMS-72 within .001"-.002"/FT.

Note: Shafting available in other lengths. Specify by similar stock number and length required.

Example: LMS-21-56" (1.2495 Diameter 56" Long)

STAINLESS GROUND SHAFTS

DIAMETER	MATERIAL
1/32" TO 1 1/4"	303 STAINLESS STEEL ROCKWELL B75-90

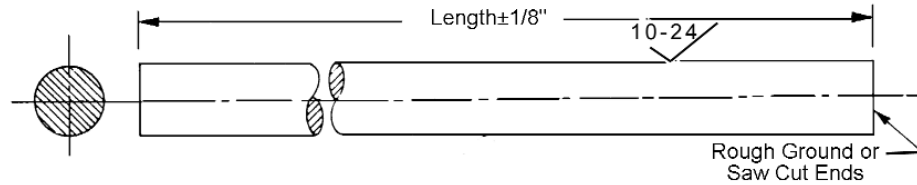

STOCK NO.	FRACT. DIA. (Ref.)*	ACTUAL DIA.	DIA. TOL. +.0000	L
S1-1	1/32	.0313	-.0002	12
S1-39		.0317	-.0002	12
S1-84	3/64	.0467	-.0002	12
S1-85	1/16	.0548	-.0002	12
S1-40		.0622	-.0002	12
S1-2		.0626	-.0002	12
S1-41		.0630	-.0002	12
S1-36	5/64	.0778	-.0002	12
S1-3		.0778	-.0002	14
S1-38		.0781	-.0002	12
S1-4		.0781	-.0002	14
S1-42	.0786	-.0002	12	
S1-37	3/32	.0934	-.0002	12
S1-5		.0934	-.0002	18
S1-30		.0938	-.0002	12
S1-6		.0938	-.0002	18
S1-43		.0942	-.0002	12
S1-8	1/8	.1247	-.0002	24
S1-9		.1250	-.0002	24
S1-31		.1251	-.0002	12
S1-7		.1251	-.0002	24
S1-44		.1255	-.0002	24
S1-45	5/32	.1559	-.0002	24
S1-10		.1562	-.0002	24
S1-46		.1567	-.0002	24
S1-11	3/16	.1872	-.0002	24
S1-12		.1875	-.0002	24
S1-47		.1880	-.0002	24
S1-48	7/32	.2184	-.0002	24
S1-13		.2187	-.0002	24
S1-49		.2192	-.0002	24
S1-72		.2490	-.0003	36
S1-73	1/4	.2495	-.0003	36
S1-14		.2497	-.0002	24
S1-50		.2497	-.0002	36
S1-15		.2500	-.0002	24
S1-51		.2500	-.0002	36
S1-52		.2505	-.0002	36

STOCK NO.	FRACT. DIA. (Ref.)*	ACTUAL DIA.	DIA. TOL. +.0000	L
S1-16	5/16	.3122	-.0002	24
S1-17		.3125	-.0002	24
S1-53		.3130	-.0002	24
S1-74	3/8	.3740	-.0003	36
S1-75		.3745	-.0003	36
S1-33		.3747	-.0002	16
S1-18		.3747	-.0002	36
S1-32		.3750	-.0002	16
S1-19		.3750	-.0002	36
S1-54		.3755	-.0002	36
S1-76	1/2	.4990	-.0005	36
S1-77		.4995	-.0005	36
S1-35		.4997	-.0002	16
S1-20		.4997	-.0002	36
S1-34		.5000	-.0002	16
S1-21	.5000	-.0002	36	
S1-55	.5005	-.0002	36	
S1-22	5/8	.6247	-.0004	36
S1-56		.6250	-.0004	36
S1-57		.6255	-.0004	36
S1-78	3/4	.7490	-.0005	36
S1-79		.7495	-.0005	36
S1-23		.7497	-.0004	36
S1-58		.7500	-.0004	36
S1-59		.7505	-.0004	36
S1-80	1	.9990	-.0005	36
S1-81		.9995	-.0005	36
S1-24		.9997	-.0004	36
S1-60		1.0000	-.0004	36
S1-61	1.0005	-.0004	36	
S1-82	1 1/4	1.2490	-.0005	36
S1-83		1.2495	-.0005	36
S1-25		1.2497	-.0004	36

* Straightness: Best efforts basis up to 3/16" diameter, straightness .0004 in/in for 7/32" diameter and up.

STAINLESS GROUND SHAFTS

DIAMETER	MATERIAL
1/8"	303 STAINLESS STEEL

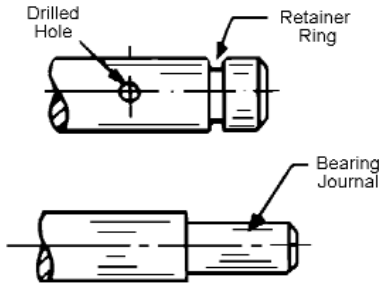
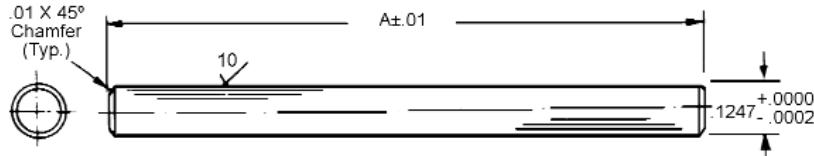

TYPICAL MODIFICATIONS

- Precision ground finish
- Straight within .0003 in./in.
- Send sketch for quotation on modifications

Available on request:

- Retainer ring grooves
- Special shaft lengths
- Journals
- Drilled holes
- Milled flats

STOCK NO.	A
S2-10	1.000
S2-11	1.125
S2-12	1.250
S2-13	1.375
S2-15	1.500
S2-16	1.625
S2-17	1.750
S2-18	1.875
S2-20	2.000
S2-21	2.125
S2-22	2.250
S2-23	2.375
S2-25	2.500
S2-26	2.625
S2-27	2.750
S2-28	2.875
S2-30	3.000
S2-31	3.125
S2-32	3.250
S2-33	3.375
S2-35	3.500
S2-36	3.625

STOCK NO.	A
S2-37	3.750
S2-38	3.875
S2-40	4.000
S2-41	4.125
S2-42	4.250
S2-43	4.375
S2-45	4.500
S2-46	4.625
S2-47	4.750
S2-48	4.875
S2-50	5.000
S2-51	5.125
S2-52	5.250
S2-53	5.375
S2-55	5.500
S2-56	5.625
S2-57	5.750
S2-60	6.000
S2-62	6.250
S2-63	6.375
S2-65	6.500
S2-66	6.625

STOCK NO.	A
S2-67	6.750
S2-70	7.000
S2-72	7.250
S2-75	7.500
S2-77	7.750
S2-80	8.000
S2-82	8.250
S2-83	8.375
S2-85	8.500
S2-90	9.000
S2-95	9.500
S2-100	10.000
S2-110	11.000
S2-120	12.000
S2-130	13.000
S2-140	14.000
S2-150	15.000
S2-160	16.000
S2-180	18.000
S2-200	20.000
S2-220	22.000
S2-240	24.000

DIAMETER	MATERIAL
3/16"	303 STAINLESS STEEL

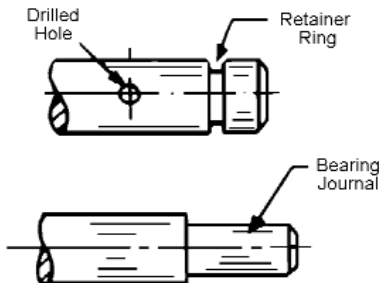
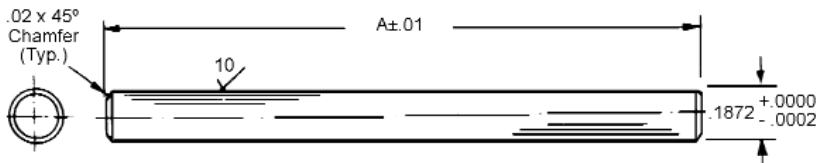

TYPICAL MODIFICATIONS

- Precision ground finish
- Straight within .0003 in./in.
- Send sketch for quotation on modifications

Available on request:

- Retainer ring grooves
- Special shaft lengths
- Journals
- Drilled holes
- Milled flats

STOCK NO.	A
S3-10	1.000
S3-11	1.125
S3-12	1.250
S3-13	1.375
S3-15	1.500
S3-16	1.625
S3-17	1.750
S3-18	1.875
S3-20	2.000
S3-21	2.125
S3-22	2.250
S3-23	2.375
S3-25	2.500
S3-26	2.625
S3-27	2.750
S3-28	2.875
S3-30	3.000
S3-31	3.125
S3-32	3.250
S3-33	3.375
S3-35	3.500
S3-36	3.625
S3-37	3.750

STOCK NO.	A
S3-38	3.875
S3-40	4.000
S3-41	4.125
S3-42	4.250
S3-43	4.375
S3-45	4.500
S3-46	4.625
S3-47	4.750
S3-48	4.875
S3-50	5.000
S3-51	5.125
S3-52	5.250
S3-53	5.375
S3-55	5.500
S3-57	5.750
S3-60	6.000
S3-62	6.250
S3-63	6.375
S3-65	6.500
S3-66	6.625
S3-67	6.750
S3-68	6.875
S3-70	7.000

STOCK NO.	A
S3-71	7.125
S3-72	7.250
S3-75	7.500
S3-77	7.750
S3-80	8.000
S3-81	8.125
S3-85	8.500
S3-90	9.000
S3-95	9.500
S3-100	10.000
S3-108	10.875
S3-110	11.000
S3-113	11.375
S3-120	12.000
S3-126	12.625
S3-130	13.000
S3-140	14.000
S3-150	15.000
S3-160	16.000
S3-180	18.000
S3-200	20.000
S3-220	22.000
S3-240	24.000

STAINLESS GROUND SHAFTS

DIAMETER	MATERIAL
1/4"	303 STAINLESS STEEL

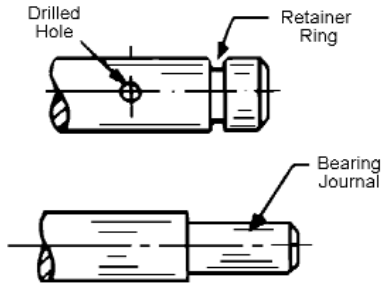
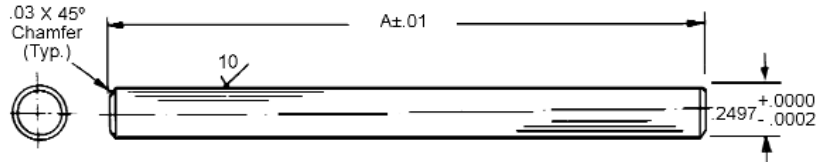

TYPICAL MODIFICATIONS

- Precision ground finish
- Straight within .0003 in./in.
- Send sketch for quotation on modifications

Available on request:

- Retainer ring grooves
- Special shaft lengths
- Journals
- Drilled holes
- Milled flats

STOCK NO.	A
S4-10	1.000
S4-11	1.125
S4-12	1.250
S4-13	1.375
S4-15	1.500
S4-16	1.625
S4-17	1.750
S4-18	1.875
S4-20	2.000
S4-21	2.125
S4-22	2.250
S4-23	2.375
S4-25	2.500
S4-26	2.625
S4-27	2.750
S4-28	2.875
S4-30	3.000
S4-31	3.125
S4-32	3.250
S4-33	3.375
S4-35	3.500
S4-36	3.625

STOCK NO.	A
S4-37	3.750
S4-38	3.875
S4-40	4.000
S4-41	4.125
S4-42	4.250
S4-43	4.375
S4-45	4.500
S4-46	4.625
S4-47	4.750
S4-48	4.875
S4-50	5.000
S4-51	5.125
S4-52	5.250
S4-53	5.375
S4-55	5.500
S4-56	5.625
S4-57	5.750
S4-58	5.875
S4-60	6.000
S4-62	6.250
S4-65	6.500
S4-67	6.750

STOCK NO.	A
S4-70	7.000
S4-72	7.250
S4-75	7.500
S4-77	7.750
S4-80	8.000
S4-82	8.250
S4-85	8.500
S4-90	9.000
S4-95	9.500
S4-100	10.000
S4-105	10.500
S4-110	11.000
S4-117	11.750
S4-120	12.000
S4-130	13.000
S4-140	14.000
S4-150	15.000
S4-160	16.000
S4-180	18.000
S4-200	20.000
S4-220	22.000
S4-240	24.000

DIAMETER	MATERIAL
5/16"	303 STAINLESS STEEL

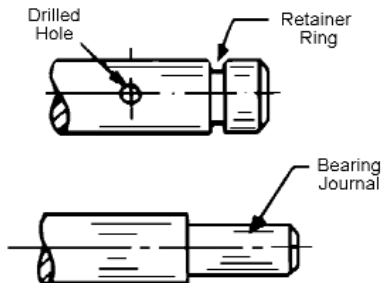
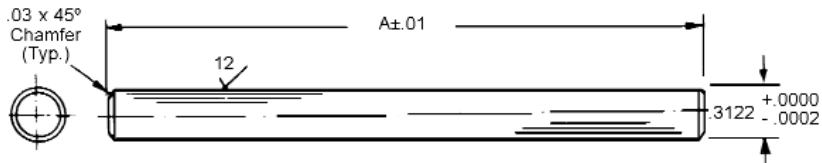

TYPICAL MODIFICATIONS

- Precision ground finish
- Straight within .0004 in./in.
- Send sketch for quotation on modifications

Available on request:

- Retainer ring grooves
- Special shaft lengths
- Journals
- Drilled holes
- Milled flats

STOCK NO.	A
S5-13	1.375
S5-15	1.500
S5-16	1.625
S5-17	1.750
S5-18	1.875
S5-20	2.000
S5-21	2.125
S5-22	2.250
S5-23	2.375
S5-25	2.500
S5-26	2.625
S5-27	2.750
S5-28	2.875
S5-30	3.000
S5-31	3.125
S5-32	3.250
S5-33	3.375
S5-35	3.500
S5-37	3.750

STOCK NO.	A
S5-38	3.875
S5-40	4.000
S5-41	4.125
S5-42	4.250
S5-43	4.375
S5-45	4.500
S5-47	4.750
S5-48	4.875
S5-50	5.000
S5-51	5.125
S5-53	5.375
S5-55	5.500
S5-56	5.625
S5-57	5.750
S5-58	5.875
S5-60	6.000
S5-62	6.250
S5-65	6.500
S5-67	6.750

STOCK NO.	A
S5-70	7.000
S5-72	7.250
S5-75	7.500
S5-77	7.750
S5-80	8.000
S5-85	8.500
S5-90	9.000
S5-95	9.500
S5-100	10.000
S5-110	11.000
S5-120	12.000
S5-130	13.000
S5-140	14.000
S5-150	15.000
S5-160	16.000
S5-180	18.000
S5-200	20.000
S5-220	22.000
S5-240	24.000

STAINLESS GROUND SHAFTS

DIAMETER	MATERIAL
3/8"	303 STAINLESS STEEL

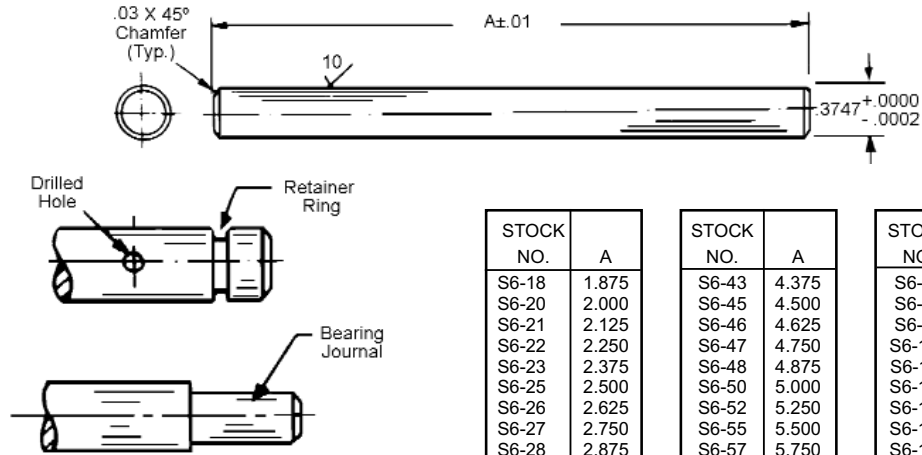

TYPICAL MODIFICATIONS

- Precision ground finish
- Straight within .0004 in./in.
- Send sketch for quotation on modifications

Available on request:

- Retainer ring grooves
- Special shaft lengths
- Journals
- Drilled holes
- Milled flats

STOCK NO.	A
S6-18	1.875
S6-20	2.000
S6-21	2.125
S6-22	2.250
S6-23	2.375
S6-25	2.500
S6-26	2.625
S6-27	2.750
S6-28	2.875
S6-30	3.000
S6-31	3.125
S6-32	3.250
S6-33	3.375
S6-35	3.500
S6-36	3.625
S6-37	3.750
S6-38	3.875
S6-40	4.000
S6-41	4.125
S6-42	4.250

STOCK NO.	A
S6-43	4.375
S6-45	4.500
S6-46	4.625
S6-47	4.750
S6-48	4.875
S6-50	5.000
S6-52	5.250
S6-55	5.500
S6-57	5.750
S6-60	6.000
S6-62	6.250
S6-65	6.500
S6-67	6.750
S6-70	7.000
S6-72	7.250
S6-75	7.500
S6-77	7.750
S6-80	8.000
S6-82	8.250
S6-85	8.500

STOCK NO.	A
S6-87	8.750
S6-90	9.000
S6-95	9.500
S6-100	10.000
S6-110	11.000
S6-120	12.000
S6-130	13.000
S6-140	14.000
S6-150	15.000
S6-160	16.000
S6-180	18.000
S6-200	20.000
S6-220	22.000
S6-240	24.000
S6-260	26.000
S6-280	28.000
S6-300	30.000
S6-320	32.000
S6-340	34.000
S6-360	36.000

DIAMETER	MATERIAL
1/2"	303 STAINLESS STEEL

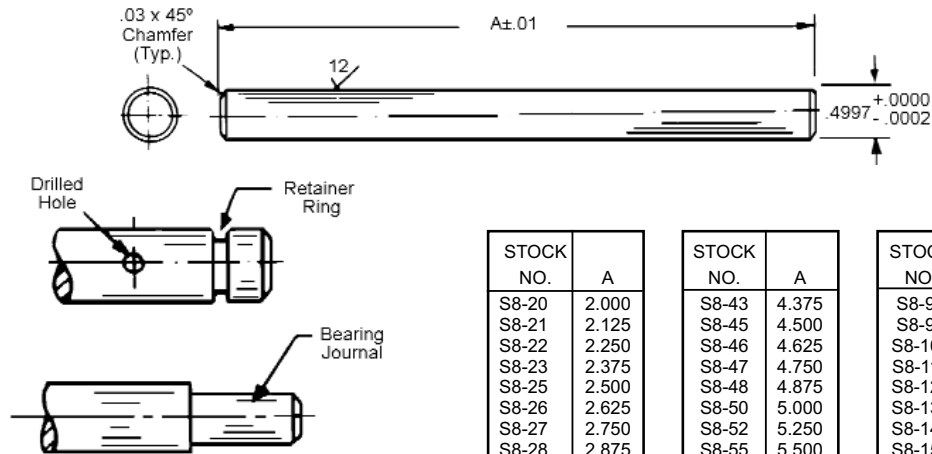

TYPICAL MODIFICATIONS

- Precision ground finish
- Straight within .0004 in./in.
- Send sketch for quotation on modifications

Available on request:

- Retainer ring grooves
- Special shaft lengths
- Journals
- Drilled holes
- Milled flats

STOCK NO.	A
S8-20	2.000
S8-21	2.125
S8-22	2.250
S8-23	2.375
S8-25	2.500
S8-26	2.625
S8-27	2.750
S8-28	2.875
S8-30	3.000
S8-31	3.125
S8-32	3.250
S8-33	3.375
S8-35	3.500
S8-36	3.625
S8-37	3.750
S8-38	3.875
S8-40	4.000
S8-41	4.125
S8-42	4.250

STOCK NO.	A
S8-43	4.375
S8-45	4.500
S8-46	4.625
S8-47	4.750
S8-48	4.875
S8-50	5.000
S8-52	5.250
S8-55	5.500
S8-57	5.750
S8-60	6.000
S8-62	6.250
S8-65	6.500
S8-67	6.750
S8-70	7.000
S8-72	7.250
S8-75	7.500
S8-77	7.750
S8-80	8.000
S8-85	8.500

STOCK NO.	A
S8-90	9.000
S8-95	9.500
S8-100	10.000
S8-110	11.000
S8-120	12.000
S8-130	13.000
S8-140	14.000
S8-150	15.000
S8-160	16.000
S8-180	18.000
S8-200	20.000
S8-220	22.000
S8-240	24.000
S8-260	26.000
S8-280	28.000
S8-300	30.000
S8-320	32.000
S8-340	34.000
S8-360	36.000

GROUND SHAFTING

DIAMETER	MATERIAL
1/8" TO 1 1/4"	COLD ROLLED STEEL 12L14 OR 12L15 ROCKWELL B75-95 (OILED TO PREVENT RUSTING)

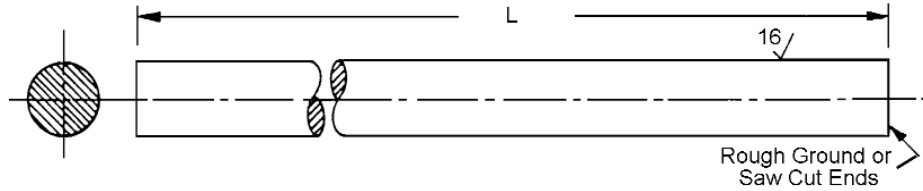

STOCK NO.	FRACT. DIA. (Ref.)	ACTUAL DIA.	L ± 1/8
S20-1	1/8	.1247	35
S20-2	3/16	.1872 +.0000	
S20-3	1/4	.2497 -.0002	
S20-4	5/16	.3122	
S20-5	3/8	.3747	
S20-6	1/2	.4997	35
S20-7	5/8	.6247 +.0000	
S20-8	3/4	.7497 -.0004	
S20-9	1	.9997	
S20-10	1 1/4	1.2497	

ULTRA GROUND SHAFTING

DIAMETER	MATERIAL
1/8"	303 STAINLESS STEEL

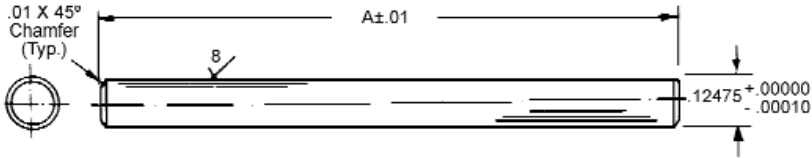

Straight within .0002 in./in.

STOCK NO.	A
S2-10-U	1.000
S2-11-U	1.125
S2-12-U	1.250
S2-13-U	1.375
S2-15-U	1.500
S2-16-U	1.625
S2-17-U	1.750
S2-18-U	1.875
S2-20-U	2.000
S2-21-U	2.125

STOCK NO.	A
S2-22-U	2.250
S2-23-U	2.375
S2-25-U	2.500
S2-26-U	2.625
S2-27-U	2.750
S2-28-U	2.875
S2-30-U	3.000
S2-31-U	3.125
S2-32-U	3.250
S2-35-U	3.500

STOCK NO.	A
S2-37-U	3.750
S2-40-U	4.000
S2-45-U	4.500
S2-50-U	5.000
S2-55-U	5.500
S2-60-U	6.000
S2-65-U	6.500
S2-70-U	7.000
S2-75-U	7.500
S2-80-U	8.000

DIAMETER	MATERIAL
3/16"	303 STAINLESS STEEL

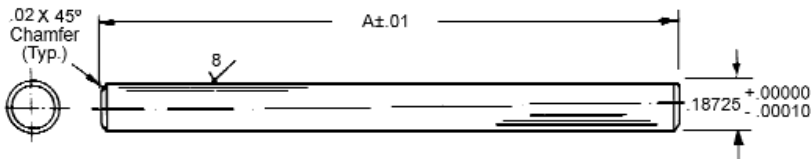

Straight within .00015 in./in.

STOCK NO.	A
S3-10-U	1.000
S3-11-U	1.125
S3-12-U	1.250
S3-13-U	1.375
S3-15-U	1.500
S3-16-U	1.625
S3-17-U	1.750
S3-18-U	1.875
S3-20-U	2.000
S3-21-U	2.125

STOCK NO.	A
S3-22-U	2.250
S3-23-U	2.375
S3-25-U	2.500
S3-26-U	2.625
S3-27-U	2.750
S3-28-U	2.875
S3-30-U	3.000
S3-31-U	3.125
S3-32-U	3.250
S3-35-U	3.500

STOCK NO.	A
S3-37-U	3.750
S3-40-U	4.000
S3-45-U	4.500
S3-50-U	5.000
S3-55-U	5.500
S3-60-U	6.000
S3-65-U	6.500
S3-70-U	7.000
S3-75-U	7.500
S3-80-U	8.000

DIAMETER	MATERIAL
1/4"	303 STAINLESS STEEL

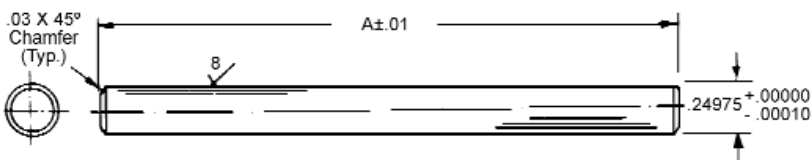

Straight within .0002 in./in.

STOCK NO.	A
S4-10-U	1.000
S4-11-U	1.125
S4-12-U	1.250
S4-13-U	1.375
S4-15-U	1.500
S4-16-U	1.625
S4-17-U	1.750
S4-18-U	1.875
S4-20-U	2.000
S4-21-U	2.125
S4-22-U	2.250

STOCK NO.	A
S4-23-U	2.375
S4-25-U	2.500
S4-27-U	2.750
S4-30-U	3.000
S4-31-U	3.125
S4-32-U	3.250
S4-33-U	3.375
S4-35-U	3.500
S4-36-U	3.625
S4-37-U	3.750
S4-40-U	4.000

STOCK NO.	A
S4-45-U	4.500
S4-50-U	5.000
S4-55-U	5.500
S4-60-U	6.000
S4-65-U	6.500
S4-70-U	7.000
S4-75-U	7.500
S4-80-U	8.000
S4-85-U	8.500
S4-90-U	9.000
S4-100-U	10.000

Special shaft length and modifications are available on request. Send sketch or print for quotation.

WOODRUFF KEYS

TYPE	MATERIAL
ANSI B17.2 - 1967, R 1978	303 STAINLESS STEEL

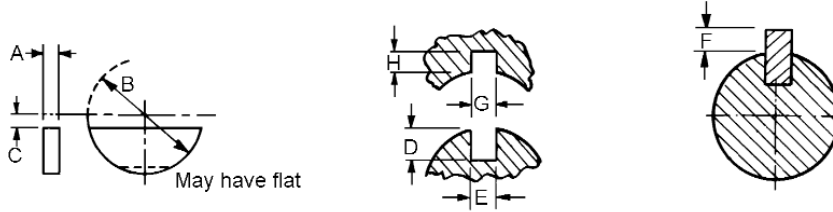

STOCK NO.	ANSI KEY NO. (Ref.)	KEY SIZE		C	D +.005	F +.010	H +.005	G +.002	E +.0015
		A +.001	B -.010						
K1-1	202	.0625	.250	.016	.0728	.0262	.0372	.0635	.0615
K1-2	202.5	.0625	.312	.016	.1038	.0262	.0372	.0635	.0615
K1-3	302.5	.0938	.312	.016	.0882	.0419	.0529	.0948	.0928
K1-4	203	.0625	.375	.016	.1358	.0262	.0372	.0635	.0615
K1-5	303	.0938	.375	.016	.1202	.0419	.0529	.0948	.0928
K1-6	403	.1250	.375	.016	.1045	.0575	.0685	.1260	.1240
K1-7	204	.0625	.500	.047	.1668	.0262	.0372	.0635	.0615
K1-8	304	.0938	.500	.047	.1511	.0419	.0529	.0948	.0928
K1-10	404	.1250	.500	.047	.1355	.0575	.0685	.1260	.1240
K1-11	305	.0938	.625	.062	.1981	.0419	.0529	.0948	.0928
K1-12	405	.1250	.625	.062	.1825	.0575	.0685	.1260	.1240
K1-9	505	.1563	.625	.062	.1669	.0731	.0841	.1573	.1553

DYNA-SPEED NEEDLE ROLLER BEARING

TYPE	MATERIAL
DRAWN CUP DESIGN FOR 1/8" TO 1" HARDENED SHAFTS	ROLLER CUP - CASE HARDENED STEEL NEEDLE ROLLERS - 52100 HARDENED STEEL BEARING CAGE - LOW HARDENED STEEL (**PLASTIC)

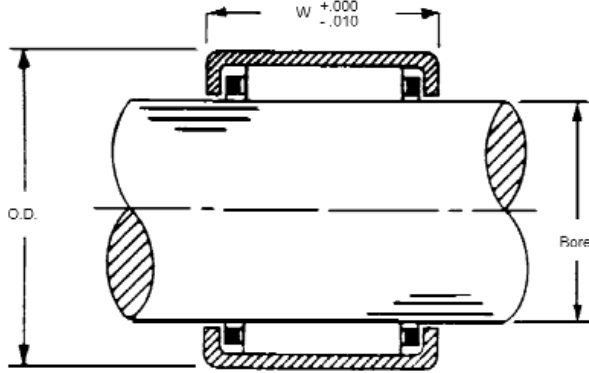

STOCK NO.	BORE	BEARING OUTSIDE DIA. (Ref.)	HOUSING BORE DIA.	BEARING W	MAX. SPEED RPM	LOAD CAPACITIES DYNAMIC (lbs.)	STATIC (lbs.)	HARDENED SHAFTING (ORDER SEPARATELY) STOCK LENGTH 12 INCHES OTHER LENGTHS ON REQUEST	
								SHAFTING STOCK NO.	SHAFT DIA.
NRB-24	1/8	.250	.2500- .2505	.250	70,000	240	165	-	.1250- .1247
NRB-34	3/16	.343	.3432- .3437	.250	70,000	400	305	-	.1875- .1872
NRB-36	3/16	.343	.3432- .3437	.375	70,000	620	530	-	.1875- .1872
NRB-44	1/4	.437	.4370- .4380	.250	55,000	360	260	-	.2500- .2495
NRB-47	1/4	.437	.4370- .4380	.438	55,000	920	870	-	.2500- .2495
NRB-55	5/16	.500	.4995- .5005	.312	44,000	650	590	-	.3125- .3120
NRB-59	5/16	.500	.4995- .5005	.562	44,000	1340	1480	-	.3125- .3120
NRB-65	3/8	.562	.5620- .5630	.312	37,000	650	610	LMS-46-12	.3750- .3745
NRB-610	3/8	.562	.5620- .5630	.625	37,000	1660	2040	LMS-46-12	.3750- .3745
NRB-86	1/2	.687	.6870- .6880	.375	27,000	1040	1210	LMS-48-12	.5000- .4995
NRB-812	1/2	.687	.6870- .6880	.750	27,000	2230	3200	LMS-48-12	.5000- .4995
NRB-107	5/8	.812	.8120- .8130	.438	22,000	1480	2100	LMS-50-12	.6250- .6245
NRB-1012	5/8	.812	.8120- .8130	.750	22,000	2700	4450	LMS-50-12	.6250- .6245
NRB-126	3/4	1.000	.9995- 1.0005	.375	18,000	1600	1860	LMS-52-12	.7500- .7495
NRB-1212	3/4	1.000	.9995- 1.0005	.750	18,000	4150	5300	LMS-52-12	.7500- .7495
NRB-168	1	1.250	1.2495- 1.2505	.500	14,000	2850	4300	LMS-56-12	1.0000- .9995
NRB-1616	1	1.250	1.2495- 1.2505	1.000	14,000	6500	10,400	LMS-56-12	1.0000- .9995

- Extremely high speed
- High load capacity
- Low profile, Light weight
- Caged needle bearings offer up to 3 times the speed of uncaged designs
- Extremely low rolling friction
- High lubrication capacity
- Low sensitivity to misalignment

BALL BEARINGS

BORE SIZE	TYPE	MATERIAL
3/64" TO 1/2"	SINGLE ROW PRECISION ABEC-3 AND ABEC-7	440C STAINLESS STEEL

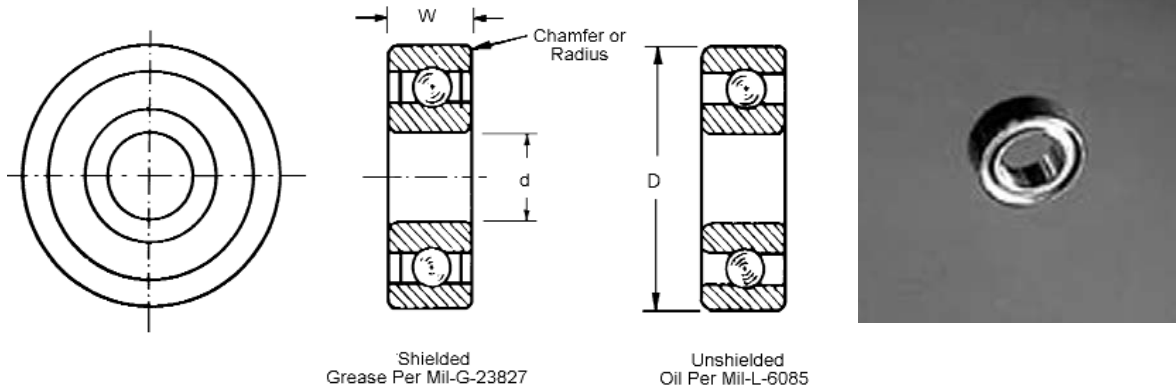

ABEC-3 STOCK NO.	ABEC-7 STOCK NO.	d	D	w	SHIELD DATA	DYNAMIC LOAD (LBS.)	STATIC LOAD (LBS.)
B1-37-Q3 B1-37-S-Q3	B1-37 B1-37-S	.0469	.1562	.0625 .0937	UNSHIELDED SHIELDED	17	6
B1-38-Q3 B1-38-S-Q3	B1-38 B1-38-S	.0550	.1875	.0781 .1094	UNSHIELDED SHIELDED	26	9
B1-33-Q3 B1-33-S-Q3	B1-33 B1-33-S	.0781	.2500	.0937 .1406	UNSHIELDED SHIELDED	36	14
B1-34-Q3 B1-34-S-Q3	B1-34 B1-34-S	.0937	.3125	.1094 .1406	UNSHIELDED SHIELDED	60	24
B1-35-Q3 B1-35-S-Q3 B1-36-Q3 B1-36-S-Q3 B1-24-Q3 B1-5-Q3	B1-35 B1-35-S B1-36 B1-36-S B1-24 B1-5	.1250	.2500 .3125 .3750	.0937 .1094 .1094 .1406 .1562 .1562	UNSHIELDED SHIELDED UNSHIELDED SHIELDED UNSHIELDED SHIELDED	33 60 68	13 24 28
B1-42-Q3 B1-42-S-Q3	B1-42 B1-42-S	.1562	.3125	.1094 .1250	UNSHIELDED SHIELDED	33	14
B1-40-Q3 B1-40-S-Q3 B1-25-Q3 B1-27-Q3 B1-26-Q3 B1-7-Q3	B1-40 B1-40-S B1-25 B1-27 B1-26 B1-7	.1875	.3125 .3750 .5000	.1094 .1250 .1250 .1562 .1960	UNSHIELDED SHIELDED UNSHIELDED SHIELDED UNSHIELDED SHIELDED	33 76 141	14 33 67
B1-29-Q3 B1-30-Q3 B1-31-Q3 B1-32-Q3 B1-28-Q3 B1-9-Q3	B1-29 B1-30 B1-31 B1-32 B1-28 B1-9	.2500	.3750 .5000 .6250	.1250 .1250 .1250 .1875 .1960 .1960	UNSHIELDED SHIELDED UNSHIELDED SHIELDED UNSHIELDED SHIELDED	37 114 158	17 57 78
B1-43-Q3 B1-43-S-Q3	B1-43 B1-43-S	.3125	.5000	.1562 .1562	UNSHIELDED SHIELDED	56	31
B1-39-Q3 B1-13-Q3	B1-39 B1-13	.3750	.8750	.2188 .2812	UNSHIELDED SHIELDED	356	176
B1-44-Q3 B1-44-S-Q3 B1-15-Q3	B1-44 B1-44-S B1-15	.5000	.8750 1.1250	.2188 .2812 .3125	UNSHIELDED SHIELDED SHIELDED	203 827	114 464

See Section K (Reference Section) for Bearing Tolerances.

BALL BEARINGS

BORE SIZE	TYPE	MATERIAL
3/64" TO 1/2"	SINGLE ROW - FLANGED PRECISION ABEC-3 AND ABEC-7	440C STAINLESS STEEL

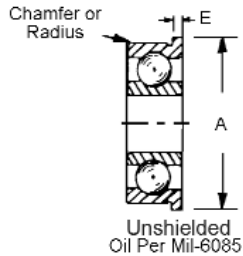
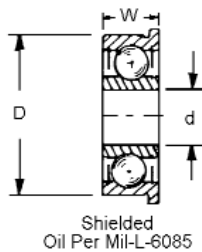
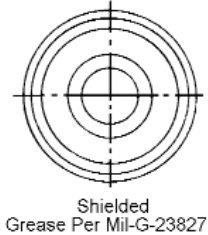

ABEC-3 STOCK NO.	ABEC-7 STOCK NO.	d	D	w	A	SHIELD DATA	E	DYNAMIC LOAD (LBS.)	STATIC LOAD (LBS.)
B2-16-Q3 B2-16-S-Q3	B2-16 B2-16-S	.0469	.1562	.0625 .0937	.203	UNSHIELDED SHIELDED	.013 .031	17	6
B2-17-Q3 B2-17-S-Q3	B2-17 B2-17-S	.0550	.1875	.0781 .1094	.234	UNSHIELDED SHIELDED	.023 .031	26	9
B2-12-Q3 B2-12-S-Q3	B2-12 B2-12-S	.0781	.2500	.0937 .1406	.296	UNSHIELDED SHIELDED	.023 .031	36	14
B2-13-Q3 B2-13-S-Q3	B2-13 B2-13-S	.0937	.3125	.1094 .1406	.359	UNSHIELDED SHIELDED	.023 .031	60	24
B2-14-Q3 B2-14-S-Q3	B2-14 B2-14-S	.1250	.2500	.0937 .1094	.296	UNSHIELDED SHIELDED	.023 .031	33	13
B2-15-Q3 B2-15-S-Q3	B2-15 B2-15-S		.3125	.1094 .1406	.359	UNSHIELDED SHIELDED	.023 .031	60	24
B2-5-Q3 B2-5-S-Q3	B2-5 B2-5-S		.3750	.1562 .1562	.440	UNSHIELDED SHIELDED	.030 .030	68	28
B2-20-Q3 B2-20-S-Q3	B2-20 B2-20-S	.1562	.3125	.1094 .1250	.359	UNSHIELDED SHIELDED	.023 .036	33	14
B2-18-Q3 B2-18-S-Q3	B2-18 B2-18-S	.1875	.3125	.1094 .1250	.359	UNSHIELDED SHIELDED	.023 .036	33	14
B2-9-Q3 B2-9-S-Q3	B2-9 B2-9-S		.3750	.1250 .1250	.422	UNSHIELDED SHIELDED	.023 .031	76	33
B2-6-Q3 B2-6-S-Q3	B2-6 B2-6-S		.5000	.1960 .1960	.565	UNSHIELDED SHIELDED	.042 .042	141	67
B2-10-Q3 B2-10-S-Q3	B2-10 B2-10-S	.2500	.3750	.1250 .1250	.422	UNSHIELDED SHIELDED	.023 .036	37	17
B2-11-Q3 B2-11-S-Q3	B2-11 B2-11-S		.5000	.1250 .1875	.547	UNSHIELDED SHIELDED	.023 .045	114	57
B2-7-Q3 B2-7-S-Q3	B2-7 B2-7-S		.6250	.1960 .1960	.690	UNSHIELDED SHIELDED	.042 .042	158	78
B2-21-Q3 B2-21-S-Q3	B2-21 B2-21-S		.3125	.5000	.1562 .1562	.547	UNSHIELDED SHIELDED	.031 .031	56
B2-8-Q3 B2-8-S-Q3	B2-8 B2-8-S	.3750	.8750	.2812 .2812	.969	UNSHIELDED SHIELDED	.062 .062	356	176
B2-22-S-Q3	B2-22-S	.5000	1.1250	.3125	1.225	SHIELDED	.062	827	464

See Section K (Reference Section) for Bearing Tolerances.

BALL BEARINGS

BORE SIZE	TYPE	MATERIAL
1/8" TO 3/4"	OPEN - PLAIN PRECISION ABEC-5	440C STAINLESS STEEL

Lubrication: Oil Per Mil-L-6085

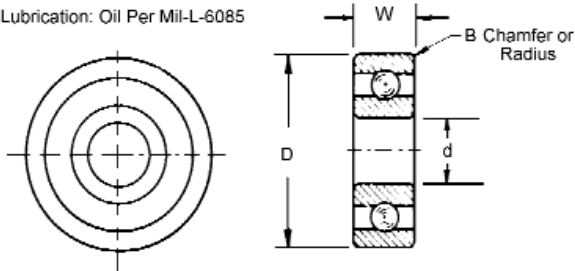

STOCK NO.	d	D	W	DYNAMIC LOAD (LBS)	STATIC LOAD (LBS)
B10-5	.1250	.3125	.1094	62	24
B10-6	.1875	.3750	.1250	79	33
B10-7	.2500	.5000	.1250	128	55
B10-8	.3125	.5000	.1562	95	47
B10-1	.3750	.6250	.1562	95	49
B10-2	.5000	.7500	.1562	111	66
B10-3	.6250	.8750	.1562	114	75
B10-4	.7500	1.0000	.1562	126	92

See Section K (Reference Section) for Bearing Tolerances.

BORE SIZE	TYPE	MATERIAL
1/8" TO 5/16"	SHIELDED - FLANGED PRECISION ABEC-3	440C STAINLESS STEEL

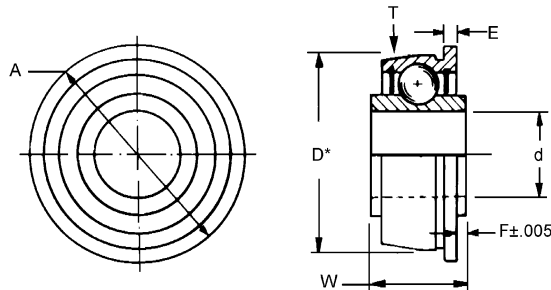

STOCK NO.	SHAFT SIZE	d	D	w	A	F	E	DYNAMIC LOAD (LBS)	STATIC T IN/FT.	TAPER
B2-1	1/8	.1250	.3757	.189	.4380		.037	69	16	.075
B2-2	3/16	.1875	.5632	.251	.6250	.015	.042	198	51	.068
B2-3	1/4	.2500	.6257	.251	.6875		.042	233	68	.068
B2-4	5/16	.3125	.6882	.251	.7500		.042	240	72	.068

*Measured at the midpoint of the raceway.

See Section K (Reference Section) for Bearing Tolerances.

BALL BEARINGS

BORE SIZE	TYPE	MATERIAL
1/8" TO 1 1/4"	SINGLE ROW - UNFLANGED PRECISION ABEC-1	52100 CHROME STEEL

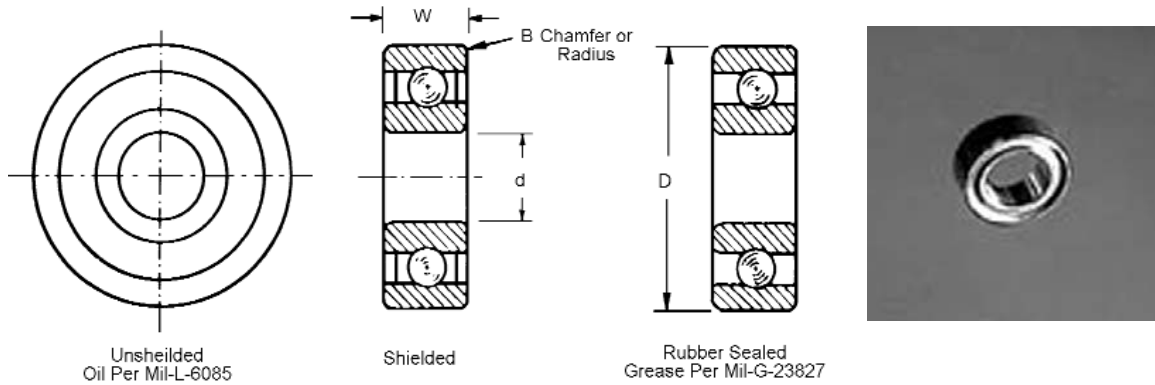

STOCK NO.	d	D	W	B	SHIELD AND LUBE DATA	DYNAMIC LOAD (LBS) CAPACITY	STATIC LOAD (LBS) CAPACITY
B11-1	.1250	.3750	.156	.005	UNSHIELDED SHIELDED RUBBER SEALED	71	29
B11-2			.156	.005			
B11-3			.156	.005			
B11-4	.1875	.5000	.156	.012	UNSHIELDED SHIELDED RUBBER SEALED	139	60
B11-5			.196	.012			
B11-6			.196	.012			
B11-7	.2500	.6250	.196	.012	UNSHIELDED SHIELDED RUBBER SEALED	159	71
B11-8			.196	.012			
B11-9			.196	.012			
B11-10	.3750	.8750	.218	.016	UNSHIELDED SHIELDED RUBBER SEALED	451	219
B11-11			.281	.016			
B11-12			.281	.016			
B11-13	.5000	1.1250	.250	.016	UNSHIELDED SHIELDED RUBBER SEALED	880	500
B11-14			.312	.016			
B11-15			.312	.016			
B1-17	.6250	1.3750	.343	.031	SHIELDED	1175	710
B1-19	.7500	1.6250	.437	.031	SHIELDED	1630	1073
B1-21	1.0000	2.0000	.500	.031	SHIELDED	2015	1408
B1-23	1.2500	2.2500	.375	.031	UNSHIELDED	1940	1582

See Section K (Reference Section) for Bearing Tolerances.

BALL BEARINGS

BORE SIZE	TYPE	MATERIAL
1/8" TO 3/8"	SINGLE ROW - FLANGED PRECISION ABEC-1	52100 CHROME STEEL

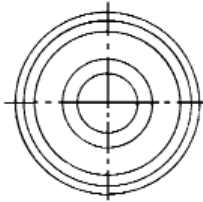

Unshielded
Oil Per Mil-L-6085

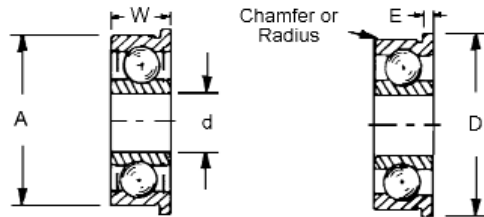

Shielded
Grease Per Mil-G-23827



STOCK NO.	d	D	W	A	SHIELD AND LUBE DATA	E	DYNAMIC LOAD (LBS) CAPACITY	STATIC LOAD (LBS) CAPACITY
B13-1			.156		UNSHIELDED			
B13-2	.1250	.3750	.156	.440	SHIELDED	.030	71	29
B13-4			.156		UNSHIELDED			
B13-5	.1875	.5000	.196	.565	SHIELDED	.042	139	60
B13-7			.196		UNSHIELDED			
B13-8	.2500	.6250	.196	.690	SHIELDED	.042	159	71
B13-10			.281		UNSHIELDED			
B13-11	.3750	.8750	.281	.969	SHIELDED	.062	451	219

See Section K (Reference Section) for Bearing Tolerances.

BORE SIZE	TYPE	MATERIAL
1/4" TO 1"	SINGLE ROW	316 STAINLESS STEEL RACEWAYS AND BALLS

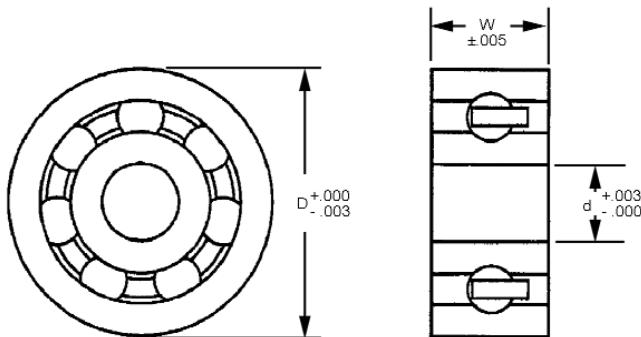

STOCK NO.	d	D	w	MAXIMUM RPM WITH NO LOAD	DYNAMIC LOAD (LBS) CAPACITY	STATIC LOAD (LBS) CAPACITY
B11-7-6	1/4	5/8	.196	2,352	89	51
B11-8-6	1/4	3/4	7/32	2,352	78	51
B11-9-6	1/4	3/4	9/32	2,352	78	51
B11-10-6	3/8	7/8	7/32	1,600	126	99
B11-11-6	3/8	7/8	9/32	1,600	126	99
B11-13-6	1/2	1 1/8	1/4	1,142	165	129
B11-14-6	5/8	1 1/8	1/4	1,142	165	129
B11-15-6	3/8	1 1/8	3/8	1,142	165	129
B11-16-6	1/2	1 1/8	3/8	1,142	165	129
B11-18-6	5/8	1 3/8	7/16	1,069	207	138
B11-19-6	3/4	1 5/8	5/16	840	234	156
B11-21-6	1	2	1/2	729	276	183

Load and speed calculations are for reference only. W.M. Berg recommends testing in actual environment to be encountered.

BALL BEARINGS

BORE SIZE	TYPE	MATERIAL
1/4" TO 1"	DOUBLE ROW	316 STAINLESS STEEL RACEWAYS AND BALLS

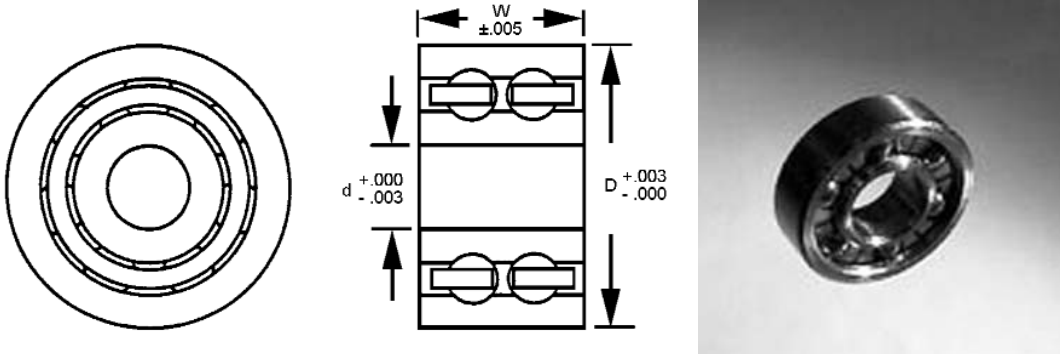

STOCK NO.	d	D	W	MAXIMUM RPM WITH NO LOAD	DYNAMIC LOAD (LBS) CAPACITY	STATIC LOAD (LBS) CAPACITY
B11D-7-6	1/4	5/8	3/8	2,352	117	76
B11D-10-6	3/8	7/8	1/2	1,600	189	148
B11D-13-6	1/2	1 1/8	7/16	1,142	247	193
B11D-17-6	5/8	1 3/8	7/16	1,069	310	207
B11D-19-6	3/4	1 5/8	5/8	840	351	234
B11D-21-6	1	2	3/4	729	414	274

Load and speed calculations are for reference only. W.M. Berg recommends testing in actual environment to be encountered.

BALL BEARINGS

BORE SIZE	TYPE	MATERIAL
3/16" TO 1"	SINGLE ROW	316 STAINLESS STEEL BALLS ACETAL PLASTIC RACEWAYS

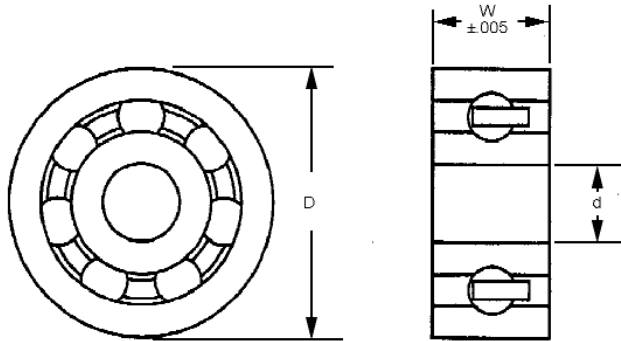

STOCK NO.	d*	D*	W	MAXIMUM RPM WITH NO LOAD	DYNAMIC LOAD (LBS) CAPACITY	STATIC LOAD (LBS) CAPACITY
B11A-4-6	3/16	1/2	5/32	3,167	17	11
B11A-5-6	3/16	5/8	.196	2,352	26	17
B11A-7-6	1/4	5/8	.196	2,352	26	17
B11A-8-6	1/4	3/4	7/32	2,352	26	17
B11A-9-6	1/4	3/4	9/32	2,352	26	17
B11A-10-6	3/8	7/8	7/32	1,600	42	33
B11A-11-6	3/8	7/8	9/32	1,600	42	33
B11A-13-6	1/2	1 1/8	1/4	1,142	55	43
B11A-15-6	3/8	1 1/8	3/8	1,142	55	43
B11A-17-6	5/8	1 3/8	3/8	1,069	69	46
B11A-18-6	5/8	1 3/8	7/16	1,069	69	46
B11A-19-6	3/4	1 5/8	5/16	840	78	52
B11A-21-6	1	2	1/2	729	92	61

* Inner and Outer Diameter Tolerancing:
 $D = 1/2" - 7/8" +.000 / -.003$
 $D = 1 1/8" - 2" +.000 / -.004$
 $d = 3/16" - 3/4" +.003 / -.000$
 $d = 1" +.004 / -.000$

Load and speed calculations are for reference only. W.M. Berg recommends testing in actual environment to be encountered.

BORE SIZE	TYPE	MATERIAL
1/4" TO 1"	DOUBLE ROW	316 STAINLESS STEEL BALLS ACETAL PLASTIC RACEWAYS

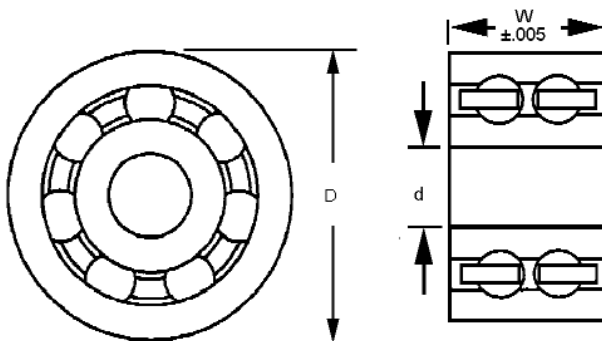

STOCK NO.	d*	D*	W	MAXIMUM RPM WITH NO LOAD	DYNAMIC LOAD (LBS) CAPACITY	STATIC LOAD (LBS) CAPACITY
B11AD-7-6	1/4	5/8	3/8	1,881	37	20
B11AD-8-6	1/4	3/4	3/8	1,881	37	20
B11AD-10-6	3/8	7/8	1/2	1,280	60	43
B11AD-13-6	1/2	1 1/8	7/16	913	78	61
B11AD-17-6	5/8	1 3/8	7/16	855	85	68
B11AD-19-6	3/4	1 5/8	5/8	672	92	75
B11AD-21-6	1	2	3/4	583	127	110

* Inner and Outer Diameter Tolerancing:
 $D = 5/8" - 7/8" +.000 / -.003$
 $D = 1 1/8" - 2" +.000 / -.004$
 $d = 1/4" - 3/4" +.003 / -.000$
 $d = 1" +.004 / -.000$

Load and speed calculations are for reference only. W.M. Berg recommends testing in actual environment to be encountered.

ANGULAR CONTACT BALL BEARINGS

BORE SIZE	TYPE	MATERIAL
1/8" TO 1/4"	NON-SEPARABLE ABEC-7	400 SERIES MARTENSITIC STAINLESS STEEL

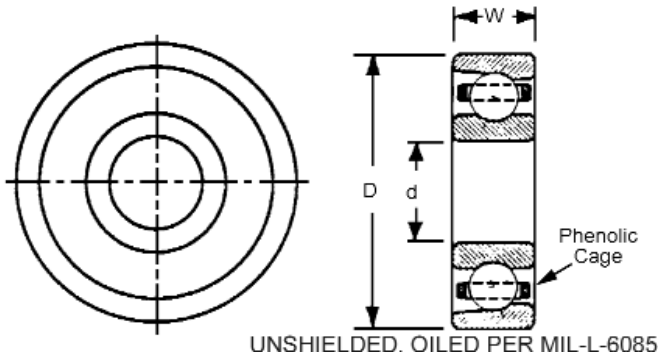

STOCK NO.	d	D	W	MAX. SPEED (RPM)	STATIC RADIAL LOAD (LBS.)	DYNAMIC RADIAL LOAD (LBS.)	STATIC THRUST LOAD (LBS)
B14-1	.1250	.3750	.1562	85,000	27	97	76
B14-2	.1875	.5000	.1562	55,000	52	190	167
B14-3	.2500	.6250	.1960	49,000	63	229	229

See Section K (Reference Section) for Bearing Tolerances.

OIL-LESS BEARINGS

BORE SIZE	TYPE	MATERIAL
3/64" TO 1/2"	PLAIN ULTRA PRECISION	SINTERED BRONZE MIL-B-5687A TYPE 1 VACUUM IMPREGNATED MIL-L-6085

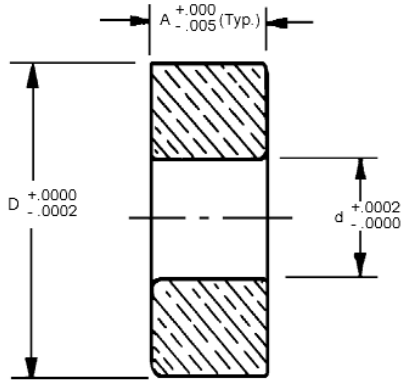

STOCK NO.	SHAFT SIZE	d	D	A
B3-1	3/64	.0469	.1563	.093
B3-2	1.4 MM	.0550	.1876	.109
B3-3	1/16	.0627	.2501	.093
B3-17	5/64	.0781	.2500	.094
B3-4	5/64	.0783	.2501	.093
B3-18	3/32	.0937	.3125	.109
B3-5	3/32	.0939	.3126	.109
B3-19	1/8	.1250	.2500	.094
B3-20	1/8	.1250	.3125	.109
B3-13	1/8	.1250	.3750	.156
B3-6	1/8	.1252	.3751	.140
B3-7	5/32	.1564	.3126	.125
B3-14	3/16	.1875	.5000	.156
B3-15	3/16	.1875	.5000	.196
B3-21	3/16	.1875	.3750	.125
B3-8	3/16	.1877	.5001	.156
B3-16	1/4	.2500	.6250	.196
B3-22	1/4	.2500	.5000	.188
B3-9	1/4	.2502	.6251	.196
B3-10	5/16	.3127	.6876	.250
B3-11	3/8	.3752	.8751	.281
B3-12	1/2	.5002	1.1251	.312



BORE SIZE	TYPE	MATERIAL
3/64" TO 1/2"	FLANGED ULTRA PRECISION	SINTERED BRONZE MIL-B-5687A TYPE 1 VACUUM IMPREGNATED MIL-L-6085

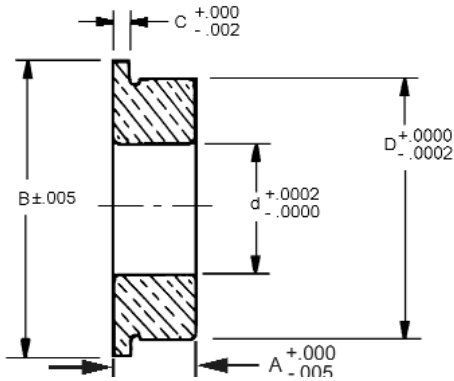

STOCK NO.	SHAFT SIZE	d	D	A	B	C
B4-1	3/64	.0469	.1563	.093	.203	.031
B4-2	1.4 MM	.0550	.1876	.109	.234	.031
B4-3	1/16	.0627	.2501	.093	.296	.031
B4-16	5/64	.0781	.2500	.094	.296	.023
B4-4	5/64	.0783	.2501	.093	.296	.031
B4-17	3/32	.0937	.3125	.109	.359	.023
B4-5	3/32	.0939	.3126	.109	.359	.031
B4-18	1/8	.1250	.2500	.094	.296	.023
B4-19	1/8	.1250	.3125	.109	.359	.023
B4-13	1/8	.1250	.3750	.156	.440	.030
B4-6	1/8	.1252	.3751	.140	.422	.031
B4-7	5/32	.1564	.3126	.125	.359	.036
B4-14	3/16	.1875	.5000	.196	.565	.042
B4-21	3/16	.1875	.3750	.125	.422	.031
B4-8	3/16	.1877	.5001	.156	.565	.042
B4-15	1/4	.2500	.6250	.196	.690	.042
B4-22	1/4	.2500	.5000	.188	.547	.045
B4-9	1/4	.2502	.6251	.196	.690	.042
B4-10	5/16	.3127	.6876	.250	.750	.042
B4-11	3/8	.3752	.8751	.281	.969	.062
B4-12	1/2	.5002	1.1251	.312	1.250	.062

OIL-LESS BEARINGS

SHAFT SIZE	TYPE	MATERIAL
1/8" TO 1/2"	PLAIN GRADE S.A.E 30	SINTERED BRONZE MIL-B-5687 TYPE 1 OIL IMPREGNATED

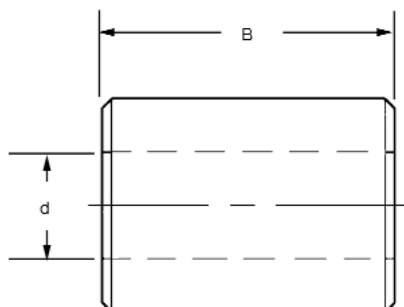
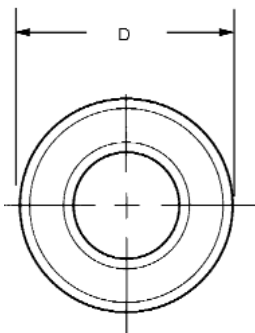

STOCK NO.	SHAFT SIZE	d +.002	D -.002	B ±.005	SHAFT STOCK NO.
B6-1 B6-2 B6-3 B6-4	1/8	.125	.252 .315	.125 .250 .375 .500	S1-8
B6-5 B6-6 B6-7 B6-30 B6-8	3/16	* * * * .1875	.315	.250 .375 .500 .625 .750	S1-11
B6-9 B6-10 B6-11 B6-12 B6-54	1/4	.250	.378	.250 .375 .500 .625 .750	LMS-5-36
B6-37 B6-13 B6-14 B6-15 B6-16 B6-55	5/16	** *** *** ** .3125 .3125	.440	.250 .375 .500 .625 .750 1.000	S1-16
B6-41 B6-42 B6-17 B6-18 B6-19 B6-20	3/8	.375	.503	.250 .375 .500 .625 .750 1.000	LMS-7-36
B6-46 B6-21 B6-22 B6-23 B6-24 B6-57	1/2	.500	.628	.375 .500 .625 .750 1.000 1.250	LMS-9-36

* d = .1875 - .1895
 ** d = .3135 - .3155
 *** d = .3135 - .3155

OIL-LESS BEARINGS

SHAFT SIZE	TYPE	MATERIAL
1/8" TO 1/2"	PLAIN AND FLANGED STYLE	TEFLON-MIL-P-19468

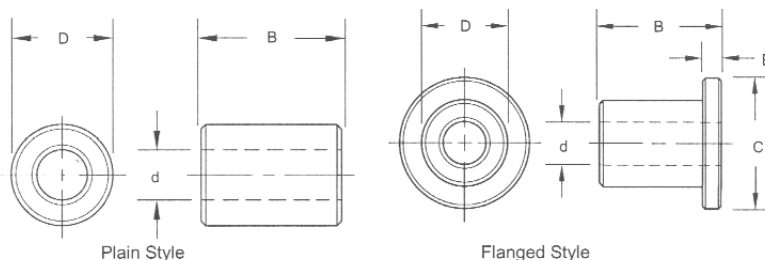

- Long Life
- Smooth Operation
- No Lubrication Required
- Minimal Breakaway Torque Resistance
- Max. PV = 10,000
- 450° F Max. Temperature Use

PLAIN STYLE	FLANGED STYLE					FLANGED ONLY		
STOCK NO.	STOCK NO.	SHAFT SIZE	d +.005	D -.000 -.003	B ±.010	C ±.010	E ±.005	SHAFT STOCK NO.
B8-1 --- B8-2 B8-3	B9-1 B9-2 B9-3 ---	1/8	.126	.254	.125 .187 .250 .375	.312	.047	S1-8
--- B8-5 B8-6 B8-7	B9-5 B9-6 B9-7 ---	3/16	.188	.317	.125 .250 .375 .500	.375	.047	S1-11
B8-9 B8-10 B8-11 B8-12	B9-9 B9-10 B9-11 ---	1/4	.251	.379	.250 .375 .500 .625	.500	.047	S1-73
--- B8-13 B8-14 B8-15 B8-16	B9-13 B9-14 B9-15 B9-16 ---	5/16	.313	.441	.250 .375 .500 .625 .750	.562	.093	S1-16
B8-17 B8-18 B8-19 B8-20	B9-17 B9-18 B9-19 B9-20	3/8	.376	.504	.375 .500 .625 .750		.093	S1-75
B8-21 B8-22 B8-23 B8-24	B9-21 B9-22 B9-23 B9-24	1/2	.501	.629	.500 .625 .750 1.000	.875	.125	S1-77

OIL-LESS BEARINGS

SHAFT SIZE	TYPE	MATERIAL
1/8" TO 1/2"	FLANGED GRADE S.A.E 30	SINTERED BRONZE MIL-B-5687 TYPE 1 OIL IMPREGNATED

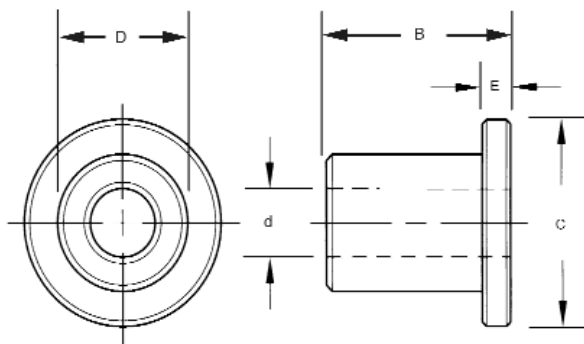

STOCK NO.	SHAFT SIZE	d +.002	D -.002	B ±.005	C ±.005	E ±.005	SHAFT STOCK NO.
B7-30 B7-31 B7-32	1/8	.125	.252	.125 .250 .375	.360	.047	S1-8
B7-1 B7-2	1/8	.125	.315	.250 .375	.375	.047	
B7-6 B7-7 B7-8 B7-35 B7-36	3/16	.187 * * * *	.315	.125 .250 .375 .500 .625	.370	.047	S1-11
B7-9 B7-10 B7-11 B7-12 B7-52	1/4	.250	.378	.250 .375 .500 .625 .750	.500	.047	LMS-5-36
B7-37 B7-38 B7-39 B7-40 B7-53	5/16	** *** *** ** .3125	.440	.250 .375 .500 .625 .750	.563 .560 .560 .563 .625	.062	S1-16 ----- ----- S1-16
B7-41 B7-42 B7-43 B7-44 B7-45 B7-54	3/8	.375	.503	.250 .375 .500 .625 .750 1.000	.625 .687	.062 .093	LMS-7-36
B7-46 B7-47 B7-48 B7-49 B7-50	1/2	.500	.628	.375 .500 .625 .750 1.000	.875	.062	LMS-9-36

* d = .188 - .189
 ** d = .313 - .314
 *** d = .3115 - .3125

PRECISION BEARINGS

SHAFT SIZE	TYPE	MATERIAL
3/16" TO 1/2"	FLANGED	6061-T6 ALUMINUM BODY WITH FRELON LINING

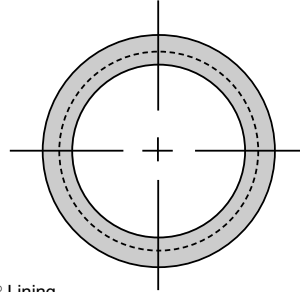
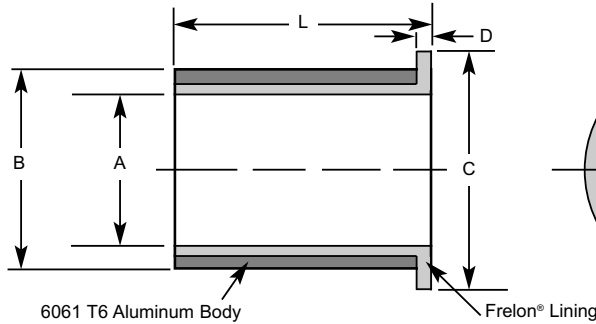

STOCK NO.	NOMINAL BEARING SIZE			A BEARING I.D.		B O.D.		C FLANGE O.D.	D FLANGE	L LENGTH	
	A	B	L	Min.	Max.	Min.	Max.	Max.	Max.	Min.	Max.
BPSF0305-2	3/16	5/16	1/4	0.1890	0.1900	0.3135	0.3145	0.4370	.0625	0.230	0.250
BPSF0305-4	3/16	5/16	1/2	0.1890	0.1900	0.3135	0.3145	0.4370	.0625	0.480	0.500
BPSF0405-2	1/4	3/8	1/4	0.2515	0.2525	0.3760	0.3770	0.5000	.0625	0.230	0.250
BPSF0405-3	1/4	3/8	3/8	0.2515	0.2525	0.3760	0.3770	0.5000	.0625	0.355	0.375
BPSF0405-4	1/4	3/8	1/2	0.2515	0.2525	0.3760	0.3770	0.5000	.0625	0.480	0.500
BPSF0610-4	3/8	5/8	1/2	0.3765	0.3775	0.6260	0.6270	0.8750	0.125	0.480	0.500
BPSF0610-6	3/8	5/8	3/4	0.3765	0.3775	0.6260	0.6270	0.8750	0.125	0.730	0.750
BPSF0710-6	7/16	5/8	3/4	0.4390	0.4400	0.6260	0.6270	0.9375	0.125	0.730	0.750
BPSF0812-4	1/2	3/4	1/2	0.5015	0.5025	0.7510	0.7520	1.0000	0.125	0.980	1.000
BPSF0812-6	1/2	3/4	3/4	0.5015	0.5025	0.7510	0.7520	1.0000	0.125	0.730	0.750
BPSF0812-8	1/2	3/4	1	0.5015	0.5025	0.7510	0.7520	1.0000	0.125	0.980	1.000

Factors Affecting Wear Rate / Life

Shafting requirements for Frelon® bearing material.

Best Performance:

- Finish of 8-12 RMS / Hardness of RC60

Acceptable Performance:

- Finish of 8-16 RMS / Hardness of RC35
- Rougher shafting can be used, but both bearing and shafting will wear at accelerated rates and binding may occur.

Chrome Plated Shafting Is Not Recommended!

Lubrication

Reduces friction 50%, and reduces heat buildup allowing greater speeds.

Recommended:

- Waylube Oil, Light Weight Oils, Petroleum Based Grease; 3-in-1 Oils

Not Recommended

- WD-40, PTFE Sprays, Fluorocarbon, Silicon

SHAFT SIZE	TYPE	MATERIAL
3/16" TO 1/2"	SLEEVE	6061-T6 ALUMINUM BODY WITH FRELON LINING

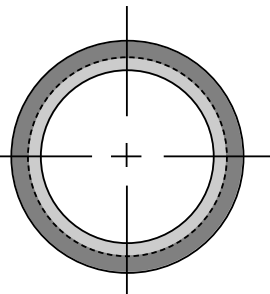
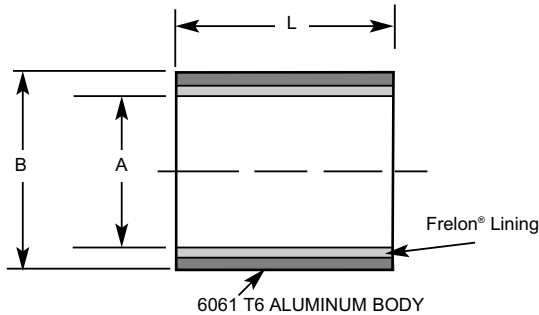

STOCK NO.	NOMINAL BEARING SIZE			A BEARING I.D.		B O.D.		L LENGTH	
	A	B	L	Min.	Max.	Min.	Max.	Min.	Max.
BPS0305-2	3/16	5/16	1/4	0.1890	0.1900	0.3135	0.3145	0.230	0.250
BPS0305-4	3/16	5/16	1/2	0.1890	0.1900	0.3135	0.3145	0.480	0.500
BPS0406-2	1/4	3/8	1/4	0.2515	0.2525	0.3760	0.3770	0.230	0.250
BPS0406-3	1/4	3/8	3/8	0.2515	0.2525	0.3760	0.3770	0.355	0.375
BPS0406-4	1/4	3/8	1/2	0.2515	0.2525	0.3760	0.3770	0.480	0.500
BPS0610-4	3/8	5/8	1/2	0.3765	0.3775	0.6260	0.6270	0.480	0.500
BPS0610-6	3/8	5/8	3/4	0.3765	0.3775	0.6260	0.6270	0.730	0.750
BPS0710-6	7/16	5/8	3/4	0.4390	0.4400	0.6260	0.6270	0.730	0.750
BPS0812-4	1/2	3/4	1/2	0.5015	0.5025	0.7510	0.7520	0.480	0.500
BPS0812-6	1/2	3/4	3/4	0.5015	0.5025	0.7510	0.7520	0.730	0.750
BPS0812-8	1/2	3/4	1	0.5015	0.5025	0.7510	0.7520	0.980	1.000

Factors Affecting Wear Rate / Life

Shafting requirements for Frelon® bearing material.

Best Performance:

- Finish of 8-12 RMS / Hardness of RC60

Acceptable Performance:

- Finish of 8-16 RMS / Hardness of RC35
- Rougher shafting can be used, but both bearing and shafting will wear at accelerated rates and binding may occur.

Chrome Plated Shafting Is Not Recommended!

Lubrication

Reduces friction 50%, and reduces heat buildup allowing greater speeds.

Recommended:

- Waylube Oil, Light Weight Oils, Petroleum Based Grease; 3-in-1 Oils

Not Recommended

- WD-40, PTFE Sprays, Fluorocarbon, Silicon

PRECISION BEARINGS

Additional Dimensional Information

STOCK NO.		MAXIMUM STATIC LOAD (LBS.)	BEARING WEIGHT	RECOMMENDED HOUSING BORE			
				SLIP FIT & EPOXY		PRESS FIT	
FLANGED	SLEEVE		OZ.	Min.	Max.	Max.	Max.
BPSF0305-2	BPS0305-2	130	0.023	.3145	0.3155	0.3125	0.3130
BPSF0305-4	BPS0305-4	272	0.044	.3145	0.3155	0.3125	0.3130
BPSF0406-2	BPS0406-2	174	0.031	.3770	0.3780	0.3750	0.3755
BPSF0406-3	BPS0406-3	268	0.044	.3770	0.3780	0.3750	0.3755
BPSF0406-4	BPS0406-4	362	0.055	.3770	0.3780	0.3750	0.3755
BPSF0610-4	BPS0610-4	542	0.20	0.6270	0.6280	0.6250	0.6255
BPSF0610-6	BPS0610-6	824	0.25	0.6270	0.6280	0.6250	0.6255
BPSF0710-6	BPS0710-6	962	0.20	0.6270	0.6280	0.6250	0.6255
BPSF0812-4	BPS0812-4	722	0.25	0.7520	0.7530	0.7500	0.7505
BPSF0812-6	BPS0812-6	1098	0.30	0.7520	0.7530	0.7500	0.7505
BPSF0812-8	BPS0812-8	1474	0.40	0.7520	0.7530	0.7500	0.7505

Installation Instructions

- Slip the bearing sleeve into the housing and epoxy into place with bonding agent. CAUTION: Do NOT let any of the adhesive touch the bearing liner. It will harden and interfere with the running clearance.
- Freeze the bearing at 0°F (-17.75°C) for 30-45 minutes. Using gloves, remove the bearings from the freezer and slip them into housing. As they heat to room temperature, full contact between the bearing and housing will be achieved. The greatest advantage to his technique over traditional pressing is greater accuracy in alignment.
- Temperature Range (-400°F/+500°F, -240°C/+260°C)

Speed Characteristics

Exceeding these speeds causes frictional heat and accelerates liner wear.

Bearing Material	No Lube Continuous Motion	No Lube Intermittent Motion	With Lubrication
Frelon® Gold	300 sfm 60 in/sec. 1.524 m/sec.	825 sfm 165 in/sec. 4.19 m/sec.	825 sfm 165 in/sec. 4.19 m/sec.

Performance Ratings (For Linear Motion)

Plane bearings are rated by their limiting PV which is a combination of load over a given surface area and velocity.

Bearing Material	Max. "PV"	Max. "P"	Max. "V" (No Lubrication)
Frelon® Gold	20,000 (psi) x ft/Min or 430 (kgf/cm ² x m/min)	3000 psi or 210.9 (kgf/cm ² x m/min)	300 sfm or 91.44 m/min.

PV = The performance measurement of plane bearings. P x V where P = pressure (load) in psi (kgf/cm²). V = velocity (speed) in sfm (m/min.)

THERMOPLASTIC BEARING

Reference Chart

The B15/16 Series is a thick-walled light-duty bearing used in many types of machinery to dampen vibration and shock loads. They are dimensionally interchangeable with most sintered metal bearings, and can be retro-fitted without changing the housing bore or shaft. Typically they're used in agricultural and exercise equipment and machinery such as woodworking, packaging, and welding equipment.

The B17/18 Series is available for situations where even the excellent abrasion resistance of the B19/20 Series is insufficient. It's superior characteristics are especially well suited for high performance requirements. Applications include, for example, pneumatic cylinders, lifting equipment, fitness machinery, industrial brakes, clutches and automotive components in general.

The B19/20 Series was initially designed for applications in chemical processing equipment. This material is a unique combination of exotic materials best suited for high load, temperature and speed applications. It is resistant to virtually any substance except for concentrated sulfuric acids. At present, this material is unique and unequalled. Applications include chemical mountings and pumps, oven manufacture, semi-conductors, film developing equipment, equipment for industrial-sized kitchens, etc.

	B15/16 SERIES	B17/18 SERIES	B19/20 SERIES
MAX. LOAD (PSI)	2,300	9,425	21,750
TEMP. RANGE			
LONG TERM.	-40f	-40f	-149f
SHORT TERM.	240f	275f	485f
WEAR BARRIER	390f	410f	600f
	175f	250f	410f
MAX. PV (NO LUB.)	9,800	28,000	100,000
SPEEDS (FPM)			
OSCILLATING (CONTINUOUS)	195	390	585
OSCILLATING (SHORT TERM)	390	590	780
ROTATIONAL (CONTINUOUS)	195	295	295
ROTATIONAL (SHORT TERM)	390	490	685
LINEAR (CONTINUOUS)	585	975	975
LINEAR (SHORT TERM)	975	1,180	1,170
COEFFICIENT OF FRICTION. DYNAMIC STEEL, DRY.	.18-.30	.08-.15	.11-.17
MAINTENANCE FREE	YES	YES	YES
DRY OPERATION	YES	YES	YES
COMPRESSIVE STRENGTH	2610 PSI	9425 PSI	21,750 PSI
SPACE REQUIREMENTS	MEDIUM WALL THICKNESS	THIN WALLED	THIN WALLED
DENSITY 1B/IN3	.040	.051	.053
MODULUS OF ELASTICITY PSI	246,500	797,500	957,000
H ₂ O ABSORPTION @50% HUM. & 72 ° F (%)	1.6	.65	.10

THERMOPLASTIC BEARINGS

BORE SIZE	SHAFT SIZE	TYPE
1/8" TO 1/2"	.1250 TO .5000	SLEEVE AND FLANGED

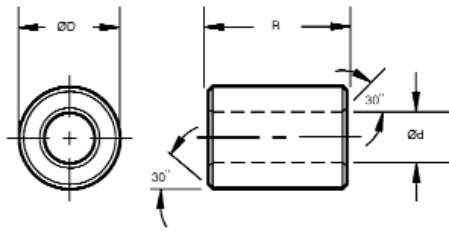

Sleeve

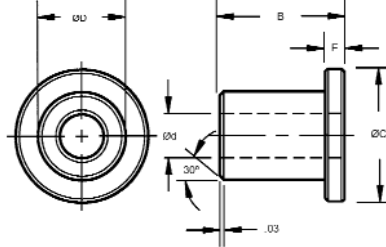

Flanged



SLEEVE STOCK NO.	FLANGED STOCK NO.	NOMINAL SIZES Ød	ØD	B	ØC	E (+0./-0055)	I.D. AFTER PRESS FIT		HOUSING BORE		SHAFT SIZE	
							MAX.	MIN.	MAX.	MIN.	MAX.	MIN.
B15-1	B16-1	1/8	1/4	1/8	.360	.047	.1280	.1262	.2515	.2510	.1250	.1241
B15-2	B16-2	1/8	1/4	3/16	.360	.047	.1280	.1262	.2515	.2510	.1250	.1241
B15-3	B16-3	1/8	1/4	1/4	.360	.047	.1280	.1262	.2515	.2510	.1250	.1241
B15-4	B16-4	1/8	1/4	3/8	.360	.047	.1280	.1262	.2515	.2510	.1250	.1241
B15-5	B16-5	3/16	1/4	1/4	.375	.032	.1905	.1887	.2515	.2510	.1875	.1866
B15-6	B16-6	3/16	1/4	3/8	.375	.032	.1905	.1887	.2515	.2510	.1875	.1866
B15-7	B16-7	3/16	1/4	1/2	.375	.032	.1905	.1887	.2515	.2510	.1875	.1866
B15-8	B16-8	3/16	5/16	3/16	.370	.047	.1905	.1887	.3140	.3135	.1875	.1866
B15-9	B16-9	3/16	5/16	1/4	.370	.047	.1905	.1887	.3140	.3135	.1875	.1866
B15-10	B16-10	3/16	5/16	5/16	.370	.047	.1905	.1887	.3140	.3135	.1875	.1866
B15-11	B16-11	3/16	5/16	3/8	.370	.047	.1905	.1887	.3140	.3135	.1875	.1866
B15-12	B16-12	3/16	5/16	1/2	.370	.047	.1905	.1887	.3140	.3135	.1875	.1866
B15-13	B16-13	1/4	5/16	1/4	.438	.032	.2539	.2516	.3140	.3135	.2500	.2491
B15-14	B16-14	1/4	5/16	3/8	.438	.032	.2539	.2516	.3140	.3135	.2500	.2491
B15-15	B16-15	1/4	5/16	1/2	.438	.032	.2539	.2516	.3140	.3135	.2500	.2491
B15-16	B16-16	1/4	3/8	3/16	.560	.047	.2539	.2516	.3765	.3760	.2500	.2491
B15-17	B16-17	1/4	3/8	1/4	.560	.047	.2539	.2516	.3765	.3760	.2500	.2491
B15-18	B16-18	1/4	3/8	5/16	.560	.047	.2539	.2516	.3765	.3760	.2500	.2491
B15-19	B16-19	1/4	3/8	3/8	.560	.047	.2539	.2516	.3765	.3760	.2500	.2491
B15-20	B16-20	1/4	3/8	1/2	.560	.047	.2539	.2516	.3765	.3760	.2500	.2491
B15-21	B16-21	1/4	3/8	5/8	.560	.047	.2539	.2516	.3765	.3760	.2500	.2491
B15-22	B16-22	1/4	3/8	3/4	.560	.047	.2539	.2516	.3765	.3760	.2500	.2491
B15-23	B16-23	5/16	3/8	1/4	.500	.032	.3164	.3141	.3765	.3760	.3125	.3116
B15-24	B16-24	5/16	3/8	3/8	.500	.032	.3164	.3141	.3765	.3760	.3125	.3116
B15-25	B16-25	5/16	3/8	1/2	.500	.032	.3164	.3141	.3765	.3760	.3125	.3116
B15-26	B16-26	5/16	7/16	3/16	.560	.062	.3164	.3141	.4390	.4385	.3125	.3116
B15-27	B16-27	5/16	7/16	1/4	.560	.062	.3164	.3141	.4390	.4385	.3125	.3116
B15-28	B16-28	5/16	7/16	5/16	.560	.062	.3164	.3141	.4390	.4385	.3125	.3116
B15-29	B16-29	5/16	7/16	3/8	.560	.062	.3164	.3141	.4390	.4385	.3125	.3116
B15-30	B16-30	5/16	7/16	1/2	.560	.062	.3164	.3141	.4390	.4385	.3125	.3116
B15-31	B16-31	5/16	7/16	5/8	.560	.062	.3164	.3141	.4390	.4385	.3125	.3116
B15-32	B16-32	5/16	7/16	3/4	.560	.062	.3164	.3141	.4390	.4385	.3125	.3116
B15-33	B16-33	3/8	7/16	1/4	.563	.032	.3789	.3766	.4390	.4385	.3750	.3741
B15-34	B16-34	3/8	7/16	3/8	.563	.032	.3789	.3766	.4390	.4385	.3750	.3741
B15-35	B16-35	3/8	7/16	1/2	.563	.032	.3789	.3766	.4390	.4385	.3750	.3741
B15-36	B16-36	3/8	1/2	3/16	.625	.062	.3789	.3766	.5015	.5010	.3750	.3741
B15-37	B16-37	3/8	1/2	1/4	.625	.062	.3789	.3766	.5015	.5010	.3750	.3741
B15-38	B16-38	3/8	1/2	5/16	.625	.062	.3789	.3766	.5015	.5010	.3750	.3741
B15-39	B16-39	3/8	1/2	3/8	.625	.062	.3789	.3766	.5015	.5010	.3750	.3741
B15-40	B16-40	3/8	1/2	1/2	.625	.062	.3789	.3766	.5015	.5010	.3750	.3741
B15-41	B16-41	3/8	1/2	5/8	.625	.062	.3789	.3766	.5015	.5010	.3750	.3741
B15-42	B16-42	3/8	1/2	3/4	.625	.062	.3789	.3766	.5015	.5010	.3750	.3741
B15-43	B16-43	3/8	1/2	1	.625	.062	.3789	.3766	.5015	.5010	.3750	.3741
B15-44	B16-44	7/16	9/16	3/8	.687	.062	.4422	.4395	.5635	.5625	.4375	.4365
B15-45	B16-45	7/16	9/16	1/2	.687	.062	.4422	.4395	.5635	.5625	.4375	.4365
B15-46	B16-46	1/2	5/8	1/4	.875	.062	.5047	.5020	.6260	.6250	.5000	.4990
B15-47	B16-47	1/2	5/8	5/16	.875	.062	.5047	.5020	.6260	.6250	.5000	.4990
B15-48	B16-48	1/2	5/8	3/8	.875	.062	.5047	.5020	.6260	.6250	.5000	.4990
B15-49	B16-49	1/2	5/8	1/2	.875	.062	.5047	.5020	.6260	.6250	.5000	.4990
B15-50	B16-50	1/2	5/8	5/8	.875	.062	.5047	.5020	.6260	.6250	.5000	.4990
B15-51	B16-51	1/2	5/8	3/4	.875	.062	.5047	.5020	.6260	.6250	.5000	.4990
B15-52	B16-52	1/2	5/8	1	.875	.062	.5047	.5020	.6260	.6250	.5000	.4990

THERMOPLASTIC BEARINGS

BORE SIZE	SHAFT SIZE	TYPE
1/8" TO 1/2"	.1250 TO .5000	SLEEVE AND FLANGED

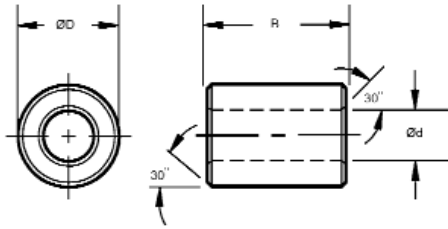

Sleeve

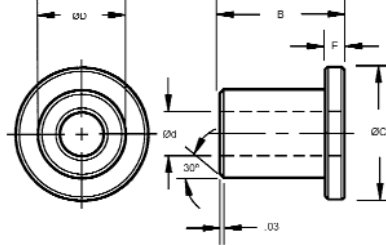

Flanged



SLEEVE STOCK NO.	FLANGED STOCK NO.	NOMINAL SIZES Ød	ØD	B	ØC	E (+0./-0055)	I.D. AFTER PRESS FIT		HOUSING BORE		SHAFT SIZE	
							MAX.	MIN.	MAX.	MIN.	MAX.	MIN.
B17-1	B18-1	1/8	3/16	3/16	.312	.032	.1269	.1251	.1878	.1873	.1243	.1236
B17-2	B18-2	1/8	3/16	1/4	.312	.032	.1269	.1251	.1878	.1873	.1243	.1236
B17-3	B18-3	1/8	3/16	3/8	.312	.032	.1269	.1251	.2503	.1873	.1243	.1236
B17-4	B18-4	3/16	1/4	1/4	.375	.032	.1892	.1873	.2503	.2497	.1865	.1858
B17-5	B18-5	3/16	1/4	3/8	.375	.032	.1892	.1873	.2503	.2497	.1865	.1858
B17-6	B18-6	3/16	1/4	1/2	.375	.032	.1892	.1873	.2503	.2497	.1865	.1858
B17-7	B18-7	1/4	5/16	1/4	.500	.032	.2521	.2498	.3128	.3122	.2490	.2481
B17-8	B18-8	1/4	5/16	3/8	.500	.032	.2521	.2498	.3128	.3122	.2490	.2481
B17-9	B18-9	1/4	5/16	1/2	.500	.032	.2521	.2498	.3128	.3122	.2490	.2481
B17-10	B18-10	5/16	3/8	1/4	.562	.032	.3148	.3125	.3753	.3747	.3115	.3106
B17-11	B18-11	5/16	3/8	3/8	.562	.032	.3148	.3125	.3753	.3747	.3115	.3106
B17-12	B18-12	5/16	3/8	1/2	.562	.032	.3148	.3125	.3753	.3747	.3115	.3106
B17-13	B18-13	5/16	3/8	3/4	.562	.032	.3148	.3125	.3753	.3747	.3115	.3106
B17-14	B18-14	3/8	15/32	1/4	.687	.046	.3773	.3750	.4691	.4684	.3740	.3731
B17-15	B18-15	3/8	15/32	3/8	.687	.046	.3773	.3750	.4691	.4684	.3740	.3731
B17-16	B18-16	3/8	15/32	1/2	.687	.046	.3773	.3750	.4691	.4684	.3740	.3731
B17-17	B18-17	3/8	15/32	3/4	.687	.046	.3773	.3750	.4691	.4684	.3740	.3731
B17-18	B18-18	7/16	17/32	1/2	.750	.046	.4406	.4379	.5316	.5309	.4365	.4355
B17-19	B18-19	1/2	19/32	1/4	.875	.046	.5030	.5003	.5941	.5934	.4990	.4980
B17-20	B18-20	1/2	19/32	3/8	.875	.046	.5030	.5003	.5941	.5934	.4990	.4980
B17-21	B18-21	1/2	19/32	1/2	.875	.046	.5030	.5003	.5941	.5934	.4990	.4980
B17-22	B18-22	1/2	19/32	3/4	.875	.046	.5030	.5003	.5941	.5934	.4990	.4980
B17-23	B18-23	1/2	19/32	1	.875	.046	.5030	.5003	.5941	.5934	.4990	.4980
B19-1	B20-1	1/8	3/16	3/16	.312	.032	.1269	.1251	.1878	.1873	.1243	.1236
B19-2	B20-2	1/8	3/16	3/8	.312	.032	.1269	.1251	.1878	.1873	.1243	.1236
B19-3	B20-3	3/16	1/4	1/4	.375	.032	.1892	.1873	.2503	.2497	.1865	.1858
B19-4	B20-4	3/16	1/4	3/8	.375	.032	.1892	.1873	.2503	.2497	.1865	.1858
B19-5	B20-5	3/16	1/4	1/2	.375	.032	.1892	.1873	.2503	.2497	.1865	.1858
B19-6	B20-6	1/4	5/16	1/4	.500	.032	.2521	.2498	.3128	.3122	.2490	.2481
B19-7	B20-7	1/4	5/16	3/8	.500	.032	.2521	.2498	.3128	.3122	.2490	.2481
B19-8	B20-8	1/4	5/16	1/2	.500	.032	.2521	.2498	.3128	.3122	.2490	.2481
B19-9	B20-9	5/16	3/8	1/4	.562	.032	.3148	.3125	.3753	.3747	.3115	.3106
B19-10	B20-10	5/16	3/8	3/8	.562	.032	.3148	.3125	.3753	.3747	.3115	.3106
B19-11	B20-11	5/16	3/8	1/2	.562	.032	.3148	.3125	.3753	.3747	.3115	.3106
B19-12	B20-12	3/8	15/32	1/4	.687	.046	.3773	.3750	.4691	.4684	.3740	.3731
B19-13	B20-13	3/8	15/32	3/8	.687	.046	.3773	.3750	.4691	.4684	.3740	.3731
B19-14	B20-14	3/8	15/32	1/2	.687	.046	.3773	.3750	.4691	.4684	.3740	.3731
B19-15	B20-15	3/8	15/32	3/4	.687	.046	.3773	.3750	.4691	.4684	.3740	.3731
B19-16	B20-16	7/16	17/32	1/2	.750	.046	.4406	.4379	.5316	.5309	.4365	.4355
B19-17	B20-17	1/2	19/32	3/8	.875	.046	.5030	.5003	.5941	.5934	.4990	.4980
B19-18	B20-18	1/2	19/32	1/2	.875	.046	.5030	.5003	.5941	.5934	.4990	.4980
B19-19	B20-19	1/2	19/32	3/4	.875	.046	.5030	.5003	.5941	.5934	.4990	.4980
B19-20	B20-20	1/2	19/32	1	.875	.046	.5030	.5003	.5941	.5934	.4990	.4980

JOURNAL BEARINGS

BORE SIZE	TYPE	MATERIAL
.2530 TO .6280	PLAIN THIN WALL	DURALON WITH TFE LINER

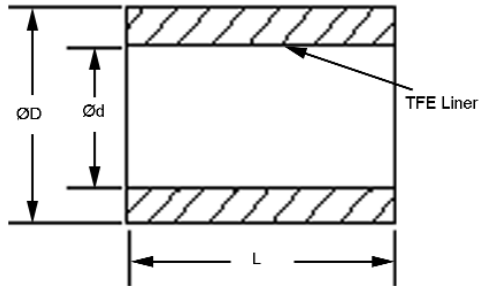

STOCK NO.	Ød +.001 -.000	ØD +.000 -.001	HOUSING BORE	WT.(REF) LB./IN.	BEARING AREA FACTOR*	L +.000 -.020
701-00004-008	.2530	.3767		.0043	.082	.250
701-00004-012	.2530	.3767		.0043	.145	.375
701-00004-016	.2530	.3767		.0043	.209	.500
701-00004-020	.2530	.3767	.3755	.0043	.273	.625
701-00004-024	.2530	.3767	.3745	.0043	.337	.750
701-00004-028	.2530	.3767		.0043	.400	.875
701-00004-032	.2530	.3767		.0043	.464	1.000
701-00004-036	.2530	.3767		.0043	.528	1.125
701-00006-008	.3780	.5017		.0060	.099	.250
701-00006-012	.3780	.5017		.0060	.177	.375
701-00006-016	.3780	.5017		.0060	.255	.500
701-00006-020	.3780	.5017	.5005	.0060	.332	.625
701-00006-024	.3780	.5017	.4995	.0060	.410	.750
701-00006-028	.3780	.5017		.0060	.488	.875
701-00006-032	.3780	.5017		.0060	.565	1.000
701-00006-036	.3780	.5017		.0060	.643	1.125
701-00008-008	.5030	.6267		.0077	.114	.250
701-00008-012	.5030	.6267		.0077	.204	.375
701-00008-016	.5030	.6267		.0077	.293	.500
701-00008-020	.5030	.6267	.6255	.0077	.382	.625
701-00008-024	.5030	.6267	.6245	.0077	.471	.750
701-00008-028	.5030	.6267		.0077	.561	.875
701-00008-032	.5030	.6267		.0077	.650	1.000
701-00008-036	.5030	.6267		.0077	.739	1.125
701-00010-012	.6280	.7517		.0094	.227	.375
701-00010-016	.6280	.7517		.0094	.326	.500
701-00010-020	.6280	.7517		.0094	.426	.625
701-00010-024	.6280	.7517		.0094	.526	.750
701-00010-028	.6280	.7517	.7505	.0094	.625	.875
701-00010-032	.6280	.7517	.7495	.0094	.725	1.000
701-00010-036	.6280	.7517		.0094	.824	1.125
701-00010-040	.6280	.7517		.0094	.924	1.250
701-00010-044	.6280	.7517		.0094	1.023	1.375

*The Bearing Area Factor is a numerical index of a bearing's dynamic performance ability and is based upon effective bearing area.

JOURNAL BEARINGS

BORE SIZE	TYPE	MATERIAL
.7530 TO 1.0030	PLAIN THIN WALL	DURALON WITH TFE LINER

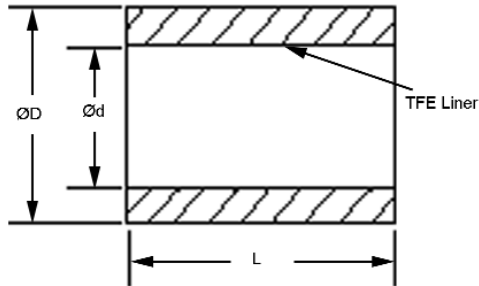

STOCK NO.	$\varnothing d$ +.001 -.000	$\varnothing D$ +.000 -.001	HOUSING BORE	WT.(REF) LB./IN.	BEARING AREA FACTOR*	L +.000 -.020
701-00012-012	.7530	.8767		.0111	.248	.375
701-00012-016	.7530	.8767		.0111	.357	.500
701-00012-020	.7530	.8767		.0111	.466	.625
701-00012-024	.7530	.8767		.0111	.574	.750
701-00012-028	.7530	.8767	.8755	.0111	.683	.875
701-00012-032	.7530	.8767	.8745	.0111	.792	1.000
701-00012-036	.7530	.8767		.0111	.901	1.125
701-00012-040	.7530	.8767		.0111	1.010	1.250
701-00012-044	.7530	.8767		.0111	1.119	1.375
701-00014-016	.8780	1.0642		.0199	.385	.500
701-00014-020	.8780	1.0642		.0199	.502	.625
701-00014-024	.8780	1.0642		.0199	.620	.750
701-00014-028	.8780	1.0642	1.0630	.0199	.737	.875
701-00014-032	.8780	1.0642	1.0620	.0199	.854	1.000
701-00014-036	.8780	1.0642		.0199	.971	1.125
701-00014-040	.8780	1.0642		.0199	1.089	1.250
701-00014-044	.8780	1.0642		.0199	1.206	1.375
701-00014-048	.8780	1.0642		.0199	1.323	1.500
701-00016-016	1.0030	1.1892		.0224	.411	.500
701-00016-020	1.0030	1.1892		.0224	.536	.625
701-00016-024	1.0030	1.1892		.0224	.661	.750
701-00016-028	1.0030	1.1892		.0224	.786	.875
701-00016-032	1.0030	1.1892	1.1880	.0224	.912	1.000
701-00016-036	1.0030	1.1892	1.1870	.0224	1.037	1.125
701-00016-040	1.0030	1.1892		.0224	1.162	1.250
701-00016-044	1.0030	1.1892		.0224	1.288	1.375
701-00016-048	1.0030	1.1892		.0224	1.413	1.500
701-00016-056	1.0030	1.1892		.0224	1.663	1.750
701-00016-064	1.0030	1.1892		.0224	1.914	2.000

*The Bearing Area Factor is a numerical index of a bearing's dynamic performance ability and is based upon effective bearing area.

COMPOSITE ANNULAR BEARINGS

BORE SIZE	TYPE	MATERIAL
.504 TO 1.254	SPLIT OUTER RACE	DURALON WITH TFE LINER

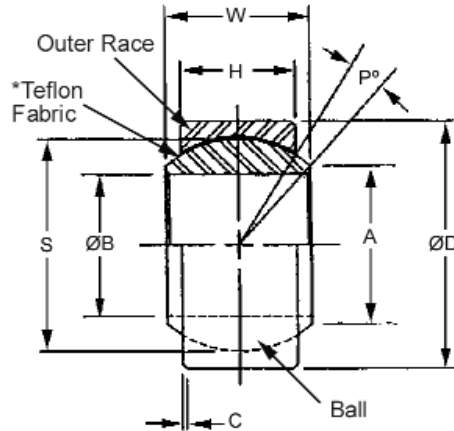

STOCK NO.	ØB MAX / MIN	ØD MAX / MIN	W +.000 -.005	H +.000 -.005	A (REF)	C HOUSING FILLET RADIUS (MAX)	P DEG MAX	S BALL OUTSIDE DIA. REF	RADIAL LIMIT LOADING RATING (LB.)
831-08-14-01	.504 .503	.8750 .8745	.437	.375	.571	.022	6	.7190	3,750
831-12-20-01	.754 .753	1.2500 1.2495	.656	.562	.858	.032	6	1.0800	8,430
831-14-23-01	.879 .878	1.4375 1.4370	.765	.656	.999	.032	6	1.2580	11,480
831-16-26-01	1.004 1.003	1.6250 1.6245	.875	.750	1.140	.032	6	1.4370	15,000
831-20-32-01	1.254 1.253	2.0000 1.9995	1.093	.937	1.424	.032	6	1.7950	23,425
838-08-14-01	.504 .503	.8750 .8745	.437	.375	.571	.022	6	.7190	3,750
838-12-20-01	.754 .753	1.2500 1.2495	.656	.562	.858	.032	6	1.0800	8,430
838-14-23-01	.879 .878	1.4375 1.4370	.765	.656	.999	.032	6	1.2580	11,480
838-16-26-01	1.004 1.003	1.6250 1.6245	.875	.750	1.140	.032	6	1.4370	15,000
838-20-32-01	1.254 1.253	2.0000 1.9995	1.093	.937	1.424	.032	6	1.7950	23,425

* Model Nos. 831 indicates no teflon fabric on the ball O.D. Model Nos. 838 indicates teflon fabric on the ball O.D.

Note: Duralon is a registered trademark of Rexnord Corporation.
Teflon is a registered trademark of E.I. DuPont.

COMPOSITE SPHERICAL BEARINGS

BORE SIZE	TYPE	MATERIAL
.252 TO 1.002	SELF LUBRICATING SPHERICAL ANNULAR	17-4 STAINLESS STEEL OUTER RACE

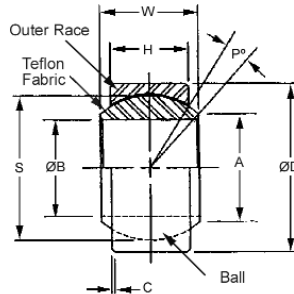

STOCK NO.	ØB +.000 -.001	ØD +.0000 -.0005	W +.000 -.010	H ±.003	A (REF)	C ±.005	P DEG MAX	S BALL OUTSIDE DIA. REF	LIMIT LOAD RATING (LB.)
821-04-10-01	.252	.6562	.343	.250	.405	.020	12	.5300	6,300
821-05-12-01	.315	.7500	.375	.281	.419	.020	11	.5625	7,490
821-06-13-01	.377	.8125	.406	.312	.475	.025	10	.6250	9,060
821-07-14-01	.440	.9062	.437	.343	.529	.025	9	.6865	11,380
821-08-16-01	.502	1.0000	.500	.390	.640	.030	9	.8125	15,750
821-09-18-01	.565	1.0937	.562	.437	.671	.030	10	.8750	18,980
821-10-19-01	.627	1.1875	.625	.500	.739	.030	9	.9680	24,180
821-12-23-01	.752	1.4375	.750	.593	.920	.030	9	1.1870	36,170
821-14-25-01	.877	1.5625	.875	.703	.978	.030	9	1.3120	48,160
821-16-28-01	1.002	1.7500	1.000	1.000	.797	.030	9	1.5000	63,100

Note: Duralon is a registered trademark of Rexnord Corporation.
Teflon is a registered trademark of E.I. DuPont.

BORE SIZE	TYPE	MATERIAL
.500 TO 2.000	SELF ALIGNING SPHERICAL ANNULAR	17-4 STAINLESS STEEL OUTER RACE

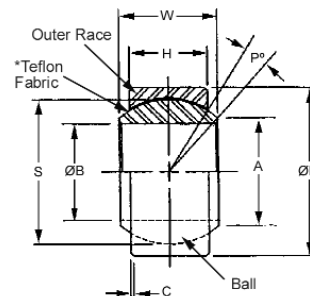

STOCK NO.	ØB +.000 -.001	ØD +.001 -.000	W +.000 -.005	H +.000 -.005	A (REF)	C +.010 -.010	P DEG MAX	S BALL OUTSIDE DIA. REF	LIMIT LOAD RATING (LB.)
801-08-14-01	.500	.8750	.437	.375	.571	.015	6	.719	5,400
801-12-20-01	.750	1.2500	.656	.562	.858	.015	6	1.080	12,140
801-14-23-01	.875	1.4375	.765	.656	.999	.015	6	1.258	16,500
801-16-26-01	1.000	1.6250	.875	.750	1.140	.015	6	1.437	21,560
801-20-32-01	1.250	2.0000	1.093	.937	1.424	.015	6	1.795	33,640
801-22-35-01	1.375	2.1875	1.187	1.031	1.531	.015	6	1.937	40,000
801-24-39-01	1.500	2.4375	1.312	1.125	1.710	.015	6	2.155	48,480
801-28-45-01	1.750	2.8125	1.531	1.312	1.995	.015	6	2.515	66,000
801-32-51-01	2.000	3.1875	1.750	1.500	2.281	.015	6	2.875	86,250

Note: Duralon is a registered trademark of Rexnord Corporation.
Teflon is a registered trademark of E.I. DuPont.

SPHERICAL BEARINGS

BORE SIZE	TYPE	MATERIAL
.1900 TO .6250	SELF LUBRICATING	440C R/C 55-62 BALL, 410 RC 23-25 HOUSING, RACE TEFLON FABRIC COATED PERM. BONDE (I.D.)

- High radial and thrust load
- Long life cycle
- Temperature range
-65°F to + 250° F

Options Available:
Bore diameters under .1900
and other materials.

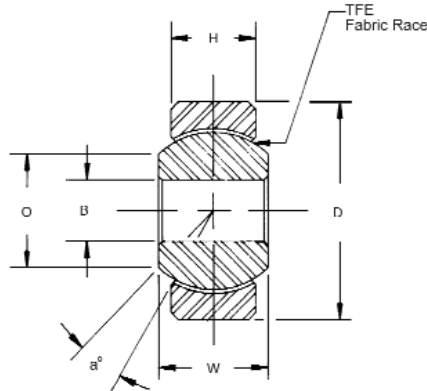

STAINLESS STEEL STOCK NUMBER	B +.0000 -.0005	D +.0000 -.0005	W +.000 -.002	H ±.005	O FLAT DIA. REF.	BALL DIA REF.	aβ	RADIAL STATIC LOAD LIMIT Lbs.
RJS-3	.1900	.5625	.281	.218	.293	.406	10	3,975
RJS-4	.2500	.6562	.343	.250	.364	.500	10	6,040
RJS-5	.3125	.7500	.375	.281	.419	.562	10	8,750
RJS-6	.3750	.8125	.406	.312	.515	.656	9	10,540
RJS-7	.4375	.9062	.437	.343	.570	.718	8	13,200
RJS-8	.5000	1.0000	.500	.390	.641	.813	8	17,900
RJS-10	.6250	1.1875	.625	.500	.739	.968	8	30,500

BORE SIZE	TYPE	MATERIAL
.1900 TO .6250	LUBRICATION REQUIRED	52100 STEEL R/C 56 MIN. HARD CHROME PLATED BALL, LOW CARBON STEEL HOUSING, RACE BRASS

- High radial and thrust load
- Long life cycle
- Temperature range
-65°F to + 250° F

Options Available:
Bore diameters under .1900 and
other materials.

** Bore diameter .3765/3745,
Housing material is low carbon
steel oil coated on outside
diameter, and race material is
low carbon steel.

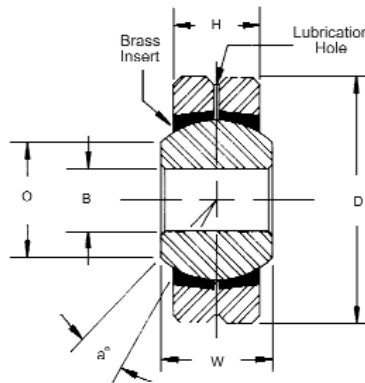

CARBON STEEL STOCK NUMBER	B +.0000 -.0005	D +.0000 -.0005	W +.000 -.005	H +.005	O FLAT DIA. REF.	BALL DIA REF.	aβ	RADIAL STATIC LOAD LIMIT Lbs.
RJC-3	.1900	.6250	.281	.187	.293	.406	12.0	2,961
RJC-4	.2500	.7500	.375	.281	.354	.515	12.5	5,246
RJC-5	.3125	.8750	.437	.313	.447	.625	12.0	6,554
RJC-6**	-	1.0000	.500	.375	.517	.718	10.5	10,785
RJC-7	.4375	1.1875	.562	.437	.586	.812	8.5	11,100
RJC-8	.5000	1.3125	.687	.531	.637	.937	10.0	15,600
RJC-10	.6250	1.5625	.875	.687	.802	1.187	10.0	25,700

THERMOPLASTIC SPHERICAL BEARINGS

BORE SIZE	TYPE	MATERIAL
.1900 TO .7500	SELF LUBRICATING	REINFORCED THERMOPLASTIC HOUSING, BALL B15/16 BEARING THERMOPLASTIC

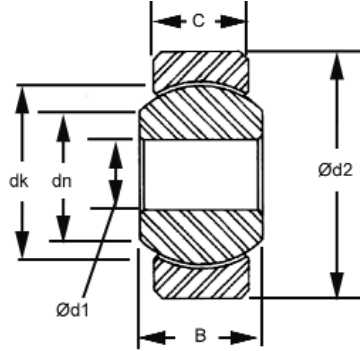

STOCK NUMBER	$\text{Ø}d1$	$\text{Ø}d2$	dn	dk REF	B	C
SKGLI-03	.1900	.5625	.307	.438	.312	.218
SKGLI-04	.2500	.6562	.354	.516	.375	.250
SKGLI-05	.3125	.7500	.447	.625	.437	.281
SKGLI-06	.3750	.8125	.504	.718	.500	.312
SKGLI-07	.4375	.9062	.600	.828	.562	.343
SKGLI-08	.5000	1.0000	.700	.938	.625	.390
SKGLI-10	.6250	1.1875	.838	1.125	.750	.500
SKGLI-12	.7500	1.4375	.978	1.312	.875	.593

THRUST BEARINGS

BORE SIZE	MATERIAL
.128 TO 1.253	410 STAINLESS STEEL OR C1075 CARBON STEEL

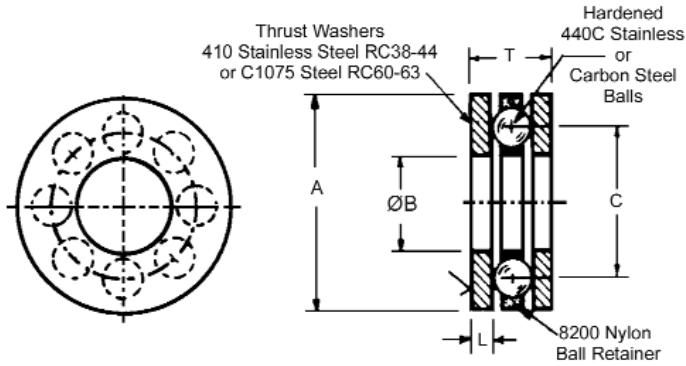

STAINLESS STEEL STOCK NUMBER	CARBON STEEL STOCK NUMBER	ØB ⁺ .005 -.000	A ⁺ .000 -.005	C	T	L ± .002	NO. OF BALLS	STAINLESS STEEL LOAD RATING AT 15 RPM	CARBON STEEL LOAD RATING AT 15 RPM
B5-1-SS	B5-1	.128	.434	9/32	.195	.050	6	63 LBS.	89 LBS.
B5-2-SS	B5-2	.190	.497	11/32	.195	.050	7	73 LBS.	104 LBS.
B5-3-SS	B5-3	.253	.559	13/32	.195	.050	8	83 LBS.	119 LBS.
B5-4-SS	B5-4	.315	.622	15/32	.195	.050	9	94 LBS.	134 LBS.
B5-5-SS	B5-5	.378	.809	19/32	.249	.062	6	104 LBS.	149 LBS.
B5-6-SS	B5-6	.503	.934	23/32	.249	.062	8	139 LBS.	198 LBS.
B5-7-SS	B5-7	.628	1.122	7/8	.342	.093	6	170 LBS.	243 LBS.
B5-8-SS	B5-8	.753	1.247	1"	.342	.093	8	255 LBS.	322 LBS.
B5-10-SS	B5-10	1.003	1.622	1-5/16	.437	.125	10	347 LBS.	496 LBS.
B5-12-SS	B5-12	1.253	1.872	1-9/16	.437	.125	14	486 LBS.	694 LBS.

ROLLER THRUST BEARINGS

BORE SIZE	MATERIAL
.252 TO 1.252	52100 CHROME STEEL ROLLERS CAGE 1008 CARBON STEEL, WASHERS 1074 STEEL

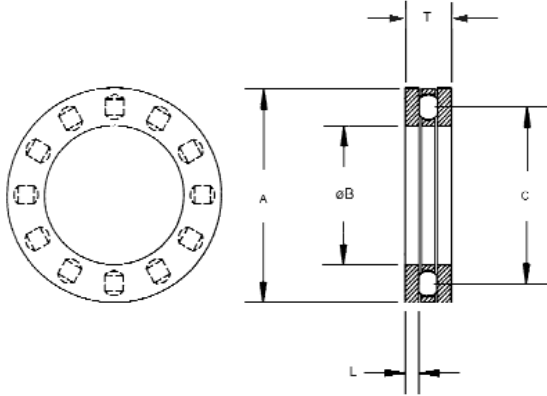

STOCK NUMBER	ØB +.005 -.000	A +.000 -.020	C	T	L +.000 -.003	DYNAMIC LOAD RATING (Lbs.)
BR5-1	.252	.677	.45	.142	.032	1,100
BR5-2	.377	.802	.58	.142	.032	1,300
BR5-3	.502	.927	.71	.142	.032	1,550
BR5-4	.627	1.115	.87	.268	.095	1,750
BR5-5	.752	1.240	.99	.268	.095	1,950
BR5-6	.877	1.427	1.14	.330	.126	2,480
BR5-7	1.002	1.552	1.27	.330	.126	2,700
BR5-8	1.252	1.927	1.58	.330	.126	3,850