

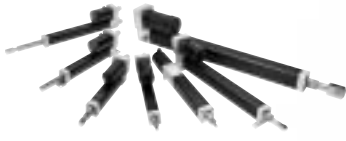

If you're in the need of linear motion components or positioning systems, you've come to the right place. In the pages of this catalog, you will find a sampling of one of the most comprehensive ranges of electric linear actuators, mechanical positioning stages, ball screws, lead screws and rotary positioning systems available from any manufacturer in the world.



ELECTRIC CYLINDERS

Primarily designed to apply a force through an extendable rod, applications for IDC Electric Cylinders have gone from being a clean and efficient replacement for hydraulic actuators and pneumatic cylinders to becoming a common alternative to many types of linear transmissions. A wide variety of mounting and coupling alternatives significantly increases the problem solving potential of IDC Electric Cylinders.



RODLESS ACTUATORS

Need more load carrying capability? Long travel, quiet operation and high moment loading differentiates IDC Rodless Actuators from other mechanical transmissions. The dichotomy of the high-force screw drive option and the high-speed belt option makes these products and ideal solution in many applications.



CARTESIAN SYSTEMS

Let Danaher Motion's experts completely design and, if you wish, assemble a multi-axis electromechanical system for you. IDC Cartesian systems are made by combining our moderate and heavy-duty actuators into 2 and 3-axis linear motion systems covering over 6048 square inches of work area. Put our engineers and technicians to work for you.



POSITIONING STAGES

IDC's family of positioning stages work best where accurate and repeatable motion is critical. IDC offers a wide variety of single and multi-axis configurations, open and closed frame stages, ball screw, lead screw or linear motor driven and overhung and constant-support geometry configurations.



ROTARY TABLES



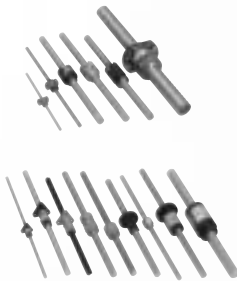



IDC rotary tables provide high rotary positioning repeatability and accuracy in driven and direct-drive models.



www.DanaherMotion.com • 815-226-2222

IDC SELECTION OVERVIEW

ACTUATORS, STAGES

Product Description			Maximum Speed mm/sec (in/sec)(Note 3)
Electric Cylinder Rod Type SEE PAGE 98		Highest Force (Thrust) Clean, Hydraulic Replacement Compact Cross Section Extends into Work Area	1300 (51.3)
Rodless Actuators Screw Drive SEE PAGE 99		Highest Force (Thrust) High Repeatability Long Travel Load Carrying Capability	1000 (40)
Rodless Actuators Belt Drive SEE PAGE 99		Very High Speed Quiet Operation Long Travel Load Carrying Capability	3000 (120)
Cartesian Systems Complete 2 & 3 Axis Assemblies SEE PAGES 100-101		Fully Engineered Multi-Axis Systems Large Work Area – 60x108 inches Multiple & Custom Configurations Long Travel	3000 (120)
Positioning Stages SEE PAGES 102-105		Smoothest Motion High Precision (Straightness & Flatness) Highest Moment Loads High Accuracy XY, XYZ, and XYθ Configurations	1300 (51.3)
Positioning Stages High Precision Ballscrew Stage SEE PAGES 107-109		Smoothest Motion High Accuracy Ideal for Vertical Applications	250 (9.8)
Positioning Stages Linear Shuttle Stage SEE PAGES 110-111		Highest Speed High Accuracy Longest Travel	3000 (120)
Positioning Stages Crossed Roller Ballscrew Stage SEE PAGE 106		Smoothest Motion High Precision High Accuracy Low-Profile Monolithic Design	250 (9.8)

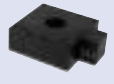
Product Description			Maximum Speed rev/sec (rev/min)
Rotary Table SEE PAGES 104-105		Accuracy to 3 arc minutes Ratios to 36:1 to 180:1 Low Static Torque Low Backlash	1.5 (900) input 0.42 (25) output
Direct Drive Rotary Table SEE PAGES 112-113		Accuracy to 0.6 arc minutes Free of Backlash and Torque Variations Compact Cross-section and Footprint High Precision	10 (600) output

Note 1: Electric Cylinders are designed primarily for thrust applications where loads are supported externally.

Note 2: Thrust ratings are based on mechanical limits rather than motor limits unless indicated.

Note 3: Maximum Speed and Thrust ratings are not necessarily achievable simultaneously.

IDC SELECTION OVERVIEW

ACTUATORS, STAGES

Repeatability mm (in) (Note 5)	Maximum Thrust N (lbs) (Notes 2 & 3)	Maximum Payload N (lbs)	Maximum Travel mm (in)
0.013 (to 0.0005)	25000 (5620)	(Note 1)	1524 (60)
0.013 (to 0.0005)	3110 (to 700)	1335 (300)	2743 (108)
0.1 (to 0.004)	1335 (300)	1335 (300)	2743 (108)
(667) (Note 6)	(1524x2743) (Note6)	to 150	60x108
0.004 (to 0.00016) bi-directional	1041 (to 234)	6592 (to 1482)	1524 (to 60)
0.001 (0.0004) bi-directional	Note 7	185 (407)	250 (10)
0.001 (0.0004) bi-directional	Note 7	75 (165)	915 (36)
0.001 (0.0004) bi-directional	Note 7	80 kg (175)	250x250 (10x10)

Repeatability arc minutes	Axial Load N (lbs)	Radial Load N (lbs)	Diameter mm (in)
0.3	480 (to 214)	152 to 304.8 (to 108)	100 to 305
0.14	980	490	100, 200 (4, 8)

Note 4: Repeatability is dependent on encoder resolution, load, friction, settling time and gain settings in the servo control.
 Note 5: Repeatability is uni-directional unless otherwise specified.
 Note 6: Cartesian systems can be configured using a combination of IDC technologies. Repeatability and Max. Thrust are dependent on the technology selected.
 Note 7: Electric Cylinders and Rodless Actuators are preferred for higher thrust applications. Consult factory for axial load applications requiring precision stages.

www.DanaherMotion.com • 815-226-2222

IDC ELECTRIC CYLINDER

ACTUATORS



IDC ELECTRIC CYLINDER

The year 2000 marked 25 years since IDC pioneered the “electric cylinder” technology as a hydraulic and pneumatic alternative. Twenty-five years of research, design and application experience are represented by IDC’s N Series and EC Series of electric cylinders. The terms robust, flexible and quick delivery are best used to contrast these product lines. Introduced in ‘98, the robust design of IDC’s EC line of electric cylinders delivers industry leading performance and specifications. High grade components are used to create a more durable, reliable and forgiving actuator.

After selling tens of thousands of special and standard N Series cylinders to thousands of customers in hundreds of applications, IDC introduced the next generation N cylinder, the N2. Years of development makes the N2 the industry’s most flexible electric cylinder available. Odds are that if you need it, an N series cylinder has done it.

Flexible – The N2 is IDC’s follow-up to the popular N Series cylinder which has found its way into thousands of applications throughout the world. Regardless of the environment or requirement, IDC has likely solved your application before with a standard or modified N Series cylinders. The new design of the N2 adds improved durability and ease-of-use to the industry’s largest selection of factory engineered options available today.

Robust – The EC series is IDC’s highest performance line of electric cylinders. Designed for the most demanding applications, the EC series is Ideal when the maximum available performance and the longest cycle life are required. Precision rolled ballscrews provide smooth motion, accurate positioning, and quiet operation.

An Electric Cylinder is Preferred When:

- Positioning an externally guided and supported load.
- Moving a load that pivots.
- There is a high concentration of airborne contaminants (rodless actuators are inherently less well protected)
- Replacing a hydraulic or pneumatic cylinder with an electro-mechanical solution.

EC Series

- Highest performance
- Precision rolled ballscrews: for smoothness and accuracy
- Robust: designed for highest loads and longest life possible
- Environmentally sealed (IP54/optional IP65)
- Metric dimensions ISO6431
- Acme screw versions available

N Series

- Smallest package
- Most flexible: (largest selection of factory-engineered options in the industry)
- English NFPA dimensions
- Improved durability
- Quick delivery
- Acme screw versions available

SPECIFICATIONS

	EC2	EC3	EC4	EC5	N2
Thrust					
N (lbs)	3600 (810)	7200 (1620)	12000 (2700)	25000 (5620)	2670 (600)
Speed					
mm/s (in/s)	1280 (50.4)	1280 (50.4)	1330 (52.4)	1330 (52.4)	760 (29.9)
Stroke					
mm (in)	600 (23.6)	750 (29.5)	1500 (59.1)	1500 (59.1)	420 (16.5)



IDC RODLESS ACTUATOR

ACTUATORS



IDC RODLESS ACTUATOR

The name "Rodless Actuator" comes from this technology's close relationship to Electric Cylinders sharing many of the same components. Rather than having a rod, Rodless Actuators incorporate a carriage supported by linear bearings. Where Electric Cylinders are designed to extend in and out of the work area delivering force or thrust, Rodless Actuators are designed to be load carrying mechanisms (up to 300 lbs) incorporating ballscrew, leadscrew, or belt drive transmissions with optional integrated gearboxes.

Rodless Actuators also share many of the fundamental design characteristics of Precision Positioning Tables. Precision Tables are designed to carry larger payloads and deliver superior repeatability and accuracy performance, Rodless Actuators offer longer travels (up to 108") and higher speeds (belt drives maximum speed 120 in/sec) at a lower price.

The R Series Rodless Actuator also forms the basis of IDC's Cartesian products. Rodless Actuators and Electric Cylinders can be combined to form a formidable XYZ positioning solution. See page 100-101.

Use Rodless Actuators (vs. Electric Cylinders) When You Need:

- To position and guide a load for the lowest system cost.
- To save space by eliminating external guides and ways.
- The shortest overall work envelope (extended length equals retracted length).
- To combine multiple units into Cartesian systems.
- To complete, compact linear positioning system.

R Series

- Ballscrew, Acme Screw & Belt Versions
- Integrated load carrying support bearing
- Integrated seal strip
- Ideal system option
- English and metric actuator carriage mounting

SPECIFICATIONS

	R2A Screw Driven	R2A Belt Driven	R3 Screw Driven	R3 Belt Driven	R4 Screw Driven	R4 Belt Driven
Thrust N (lbs)	450 (100)	100	600	200	800	300
Speed mm/s (in/s)	760 (30)	2000 (80)	760 (30)	3000 (120)	1000 (40)	3000 (120)
Travel mm (in)	1830 (72)	1830 (72)	1830 (72)	1830 (72)	2740 (108)	2740 (108)
Loading N (lbs)	220 (50)	220 (50)	440 (100)	440 (100)	1300 (300)	1300 (300)



IDC CARTESIAN SYSTEMS OVERVIEW

ACTUATOR SYSTEMS



IDC CARTESIAN SYSTEMS

Overview

Cartesian Actuator Systems combine R3 or R4 Series rodless actuators to create two and three-axis linear motion systems. Work areas range up to 4 by 8 feet, depending on mechanical configuration, with optional Z-axis options up to 12 inches. IDC offers a complete system, including motors and controls, a driveshaft, interface brackets, and cable track kits. Factory-based engineering services include component selection assistance, CAD drawings of your system, and your choice of shipped assembled, or as components.

Design Services

To assist in the integration process, IDC's engineering staff offers the following:

- Component sizing and part number selection
- System configuration
- Verifying available work area, load/actuator interference checking
- Dimensional/layout drawing of Assembled System
- Shipped as a fully assembled, crated system (optional)

Cartesian Actuator Capabilities

- Speeds up to 120 in/sec
- Payloads from 0 to 150 lb
- Speed/Thrust performance characterized for all cataloged motors
- 2", 3" and 4" Brushless Servo Motors
- NEMA 23, 34, and 42 Step Motors

Custom Capabilities

Consult the factory regarding the following options:

- Larger work areas
- Higher payloads
- Precision planetary gearheads, mounted between motor and actuator, for lower backlash or alternate speed range
- Custom carriage options for special Z-axis or special mounting hole pattern
- Complete Cartesian Systems, pre-assembled by our factory technical staff
- High flex cables for motors, limit switches

MULTI-AXIS INTEGRATION COMPONENTS

Driveshaft

Tubular driveshaft with high torque flexible couplings, available in lengths as required by your application.



Idler/Driven Actuators

Idler actuators provide external bearing support to build low-cost systems when actuators are mounted less than 15" apart. Driven actuators are used with a driveshaft.



Brackets/Adapters

Standard mounting brackets are available for the following:

- Z-axis actuators
- A second Y actuator for added stiffness
- Inverted Y axis actuator(s)
- X-axis adapter to aluminum framing vendors (universal for Item, 80/20, Bosch and others)

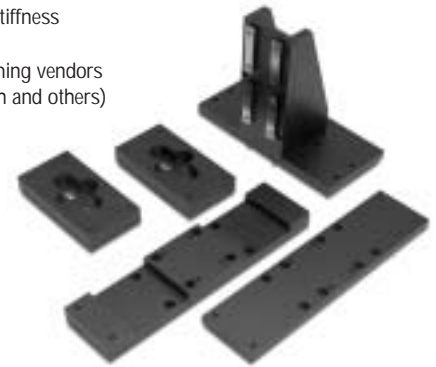

Cable Track Kits

Flexible cable track for routing motor, feedback, and limit switch cables to Y and Z axes.

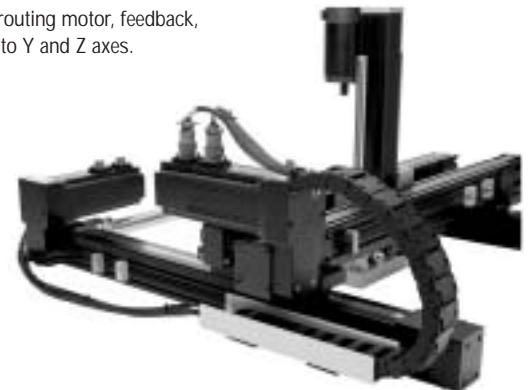

IDC CARTESIAN SYSTEMS OVERVIEW

ACTUATOR SYSTEMS

COMMON SYSTEM TYPES

TYPE 1 - DUAL X WITH DRIVESHAFT, SINGLE Y-AXIS

- Basic Cartesian system
- Driveshaft increases accuracy
- Y-axis travel up to 60" (1.5 m)

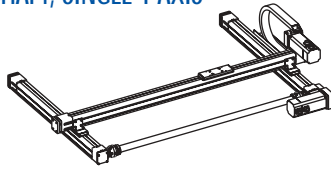

X/X': Two R3 or R4 Series, coupled with driveshaft
 Y: One R3 or R4 Series

Sample Components List

- X-axis: R3S33V-50T-S-24-AR-ASE
 X'-axis: R3-T-SR-24-ASE
 Y-axis: R3S23V-20T-18-BR-ASE
 Driveshaft: DS-R3-25
 Cable Track: CT-R3-R3-24-B
 Limit Switches: 2 RPI-25 (home),
 4 RP2-25 (end of travel)

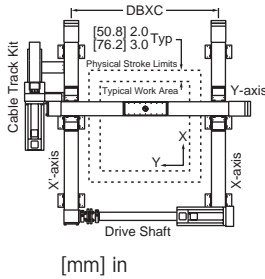

TYPE 2 - DUAL X WITH DRIVESHAFT, DUAL Y-AXIS

- Recommended for Z-axis application
- Stiffest Y-axis configuration
- Driveshaft increases accuracy
- Y-axis travel up to 60" (1.5 m)

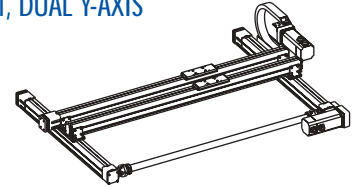

X/X': Two R3 or R4 Series, coupled with driveshaft
 Y: Two R3 or R4 Series: One with motor, one Idler

Sample Components List

- X-axis: R3B32-50T-S-60-AR-ASE
 X'-axis: R3-T-SR-60-ASE
 Y-axis: R3B32-50T-S-42-AR-ASE
 Y'-axis: R3-IDLER-42-ASE
 Driveshaft: DS-R3-49
 Cable Track: CT-R3-R3-60-A
 Limit Switches: 2 RPI-25 (home),
 4 RP2-25 (end of travel)
 Mtg. Brackets: 2 MB-2R3-R3 (mounts Y & Y' to X & X' carriages)

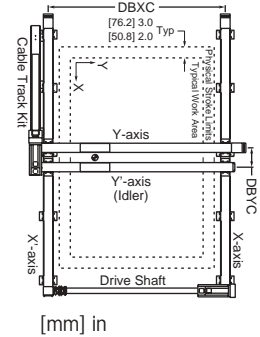

TYPE 3 - DUAL X WITH IDLER, SINGLE Y-AXIS

- Lowest cost X-Y system
- 15" max. spacing between X and X'

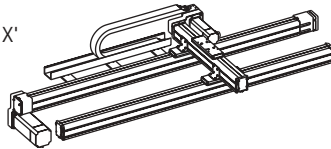

X/X': Two R3 or R4 Series: Screw or belt, one with motor, one Idler
 Y: One R3 or R4 Series

Sample Components List

- X-axis: R4B41-100T-36-CR-ASE
 X'-axis: R4-IDLER-36-ASE
 Y-axis: R4B32-501B-12-PR-ASE
 Driveshaft: Not required
 Cable Track: Optional
 Limit Switches: 2 RPI-25 (home),
 4 RP2-25 (end of travel)
 Mtg. Brackets: 6 MB-R4-AF1 (mounts X & X' to aluminum framing)

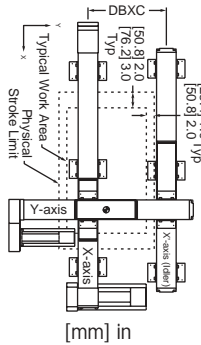

TYPE 4 - DUAL X WITH IDLER, DUAL Y-AXIS

- Lowest cost Z-axis capable system
- 15" max. spacing between X and X'
- Increased roll stiffness (Y-axis)

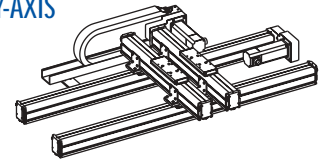

X/X': Two R3 or R4 Series: One with motor, one Idler, screw or belt
 Y: Two R3 or R4 Series: One with motor, one Idler

Sample Components List

- X-axis: R3B23-105B-24-PR-ASE
 X'-axis: R3-IDLER-24-ASE
 Y-axis: R3B23-102B-18-PR-ASE
 Y'-axis: R3-IDLER-18-ASE
 Driveshaft: Not required
 Cable Track: Optional
 Limit Switches: 2 RPI-25 (home),
 4 RP2-25 (end of travel)
 Mtg. Brackets: 2 MB-2R3-R3 (mounts Y & Y' to X & X' carriages)

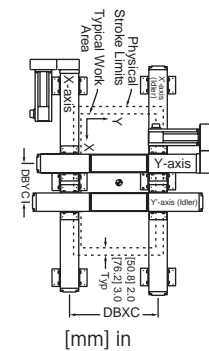

		R3/R3 Driveshaft (Type 1, 2)	R4/R4 Driveshaft (Type 1, 2)	R3/R3 Idler (Type 3, 4)	R4/R4 Idler (Type 3, 4)
Max Travel Area (X by Y)	mm (in)	2750 x 1520 (108 x 60)	2750 x 1520 (108 x 60)	2750 x 610 (108 x 24)	1220 x 610 (48 x 24)
Max. Spacing Between X & X'	mm (in)	1700 (to 67)	1700 (to 67)	380 (to 15)	380 (to 15)
Load Capacity	N (lb)	220 (0-50)	660 (0-150)	220 (0-50)	660 (0-150)
Max. Speed	mm/s (in/s)	3000 (120)	3000 (120)	3000 (120)	3000 (120)
Repeatability (per axis)	mm (in)	±0.004 (±0.10)	±0.004 (±0.10)	±0.004 (±0.10)	±0.004 (±0.10)
Backlash					
20T, 30T models	mm (in)	±0.75 (0.03)	±0.75 (0.03)	±0.75 (0.03)	±0.75 (0.03)
50T, 70T, 100T models	mm (in)	±1.50 (0.06)	±1.50 (0.06)	±1.50 (0.06)	±1.50 (0.06)
Motor Types Available		1.8' Step Motor Brushless Servo	1.8' Step Motor Brushless Servo	1.8' Step Motor Brushless Servo	1.8' Step Motor Brushless Servo

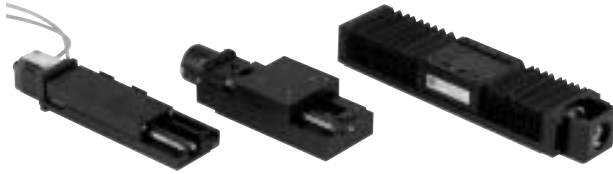

IDC STAGES

Do I need a Precision Table?

The first step toward choosing the correct motion system for your application, before considering specific performance parameters or technologies, is to consider which type of motion system might be the best fundamental fit for your application goals.

Electric Cylinders are essentially thrust producing devices that are best suited for applications requiring high axial force with the moment and side loads already properly supported. Screw driven Rodless Actuators are also thrust producing devices that are best for axial force applications where the space is limited and a payload must also be supported or carried. As individual components, Rodless Actuators are not well suited for moment loading; however, they can be effectively combined into complete Cartesian Systems for some multi-axis applications. For higher speed, lower thrust applications, Rodless Actuators can be repeatably driven with a timing belt instead of a screw. Linear Motor Actuators are ideal for high throughput applications that require repeatability and high system dynamics. Precision Positioning Tables are best suited for applications where the accuracy and repeatability requirements are more important than axial thrust of the drive train. Precision Positioning Tables can also be used in less precise applications where adequate moment load support is necessary. Precision Positioning Tables are ideal building blocks for complete multi-axis positioning systems.



STAGES SELECTION OVERVIEW

STAGES

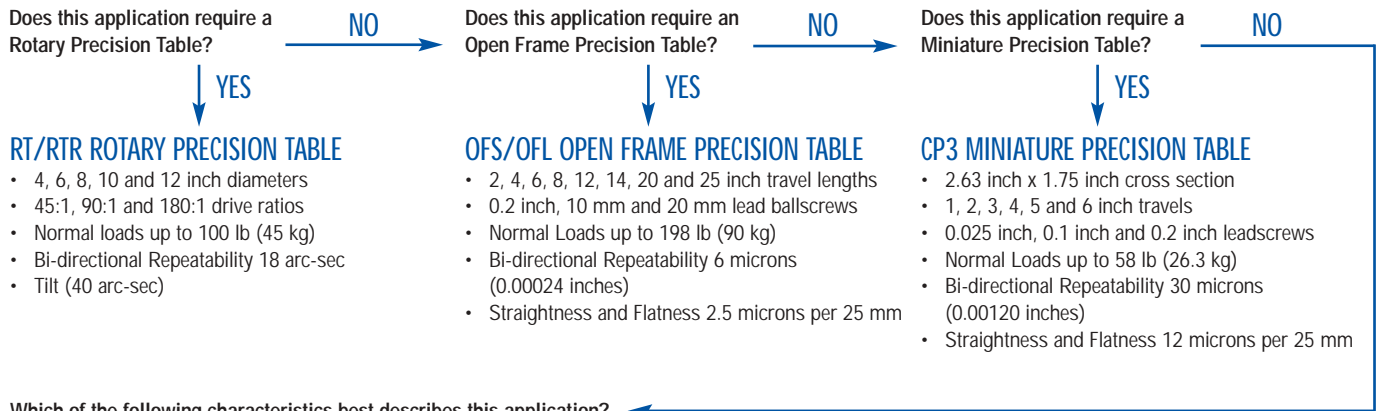

Non-recirculating Bearings

- Shorter Travels
- No Heavy Moment Loading
- Cantilevered Top
- Ultra Smooth Motion
- No Heavy Impact Loading
- Acceleration up to 1.0 g

Recirculating Bearings

- Longer Travels
- Moment Loading
- Protective Covers
- Very Smooth Motion
- Impact Loading
- Acceleration up to 2.0 g

Does this application require a small footprint or protective covers? **NO** → Does this application require a wider footprint or longer travel? **NO** → Please refer to the Recirculating Bearing Precision Table Choices.

YES → **PB4 ULTRA PRECISION TABLE**

- 4 inch x 2.5 inch cross section
- 2 and 4 inch travels
- 2.5 mm and 0.2 inch lead ballscrews
- Normal Loads up to 79 lb (35.8 kg)
- Bi-directional Repeatability 6 microns (0.00024 inches)
- Straightness and Flatness 2 microns per 25 mm
- Protective neoprene bellows covers

YES → **CP8 ULTRA PRECISION TABLE**

- 8 inch x 2.5 inch cross section
- 5, 7, 9 and 12 inch travels
- 2.5 mm, 0.2 inch and 0.5 inch lead ballscrews
- Normal Loads up to 279 lb (127 kg)
- Bi-directional Repeatability 6 microns (0.00024 inches)
- Straightness and Flatness 2 microns per 25 mm

Does this application require normal loading or travel up to the following limits? (If the answer to these questions is more, please contact IDC to discuss your application.)

97 lb (44 kg)

RB4A HIGH PRECISION TABLE

- 4 inch x 2.5 inch cross section
- 2, 4, 6, 8, 12 and 16 inches
- 2.5 mm, 0.2 inch and 0.5 inch lead ballscrews
- Normal Loads up to 97 lb (44 kg)
- Bi-directional Repeatability 6 microns (0.00024 inches)
- Straightness and Flatness 2 microns per 25 mm
- Protective neoprene bellows covers

425 lb (193 kg)

RB6 AND RC6 HIGH PRECISION TABLES

- 6 inch x 3.5 inch cross section
- 6, 12, 18, 24, 30, 36, 42 and 48 inch travels
- 0.2 inch, 10 mm and 20 mm lead ballscrews
- Normal Loads up to 425 lb (193 kg)
- Bi-directional Repeatability 6 microns (0.00024 inches)
- Straightness and Flatness 2 microns per 25 mm

1250 lb (567 kg)

RB8 HIGH PRECISION TABLE

- 8 inch x 3.5 inch cross section
- 6, 12, 18, 24, 30, 36, 42, 48, 54 and 60 inch travels
- 0.2 inch, 10 mm and 1.0 inch lead ballscrews
- Normal Loads up to 1250 lb (567 kg)
- Bi-directional Repeatability 6 microns (0.00024 inches)
- Straightness and Flatness 2 microns per 25 mm
- Protective neoprene bellows covers

Which covers are needed?

Protective Bellows

Aluminum Plate

RB6 HIGH PRECISION TABLE

RC6 HIGH PRECISION TABLE

IDC STAGE DATA

STAGES

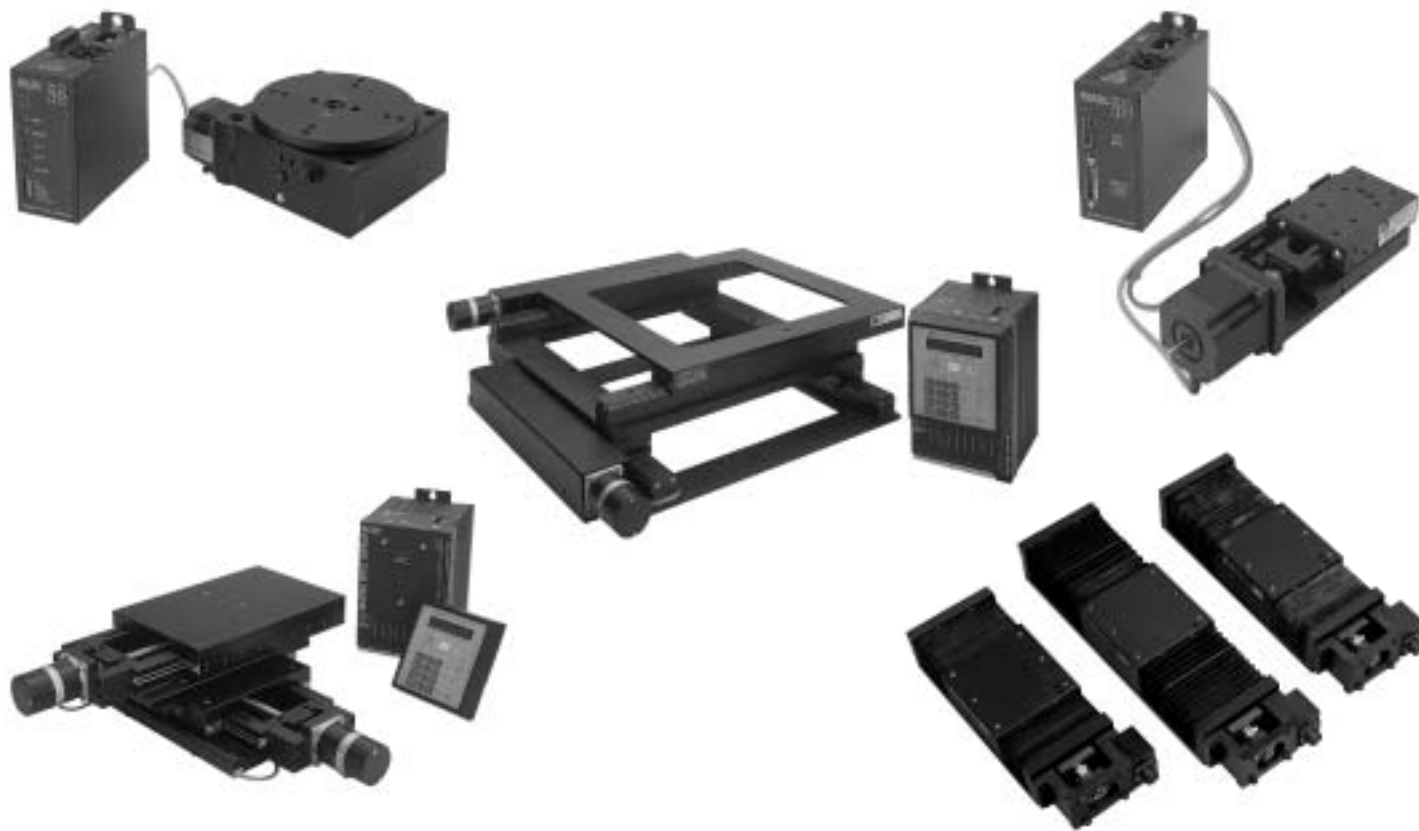

STAGE DATA

	RTR	OFS/OFL	CP3	PB4	CP8
Type	Rotary Axis	Linear Axis	Linear Axis	Linear Axis	Linear Axis
Series	Precision	Precision	Precision	Ultra Precision	Ultra Precision
Travel or Diameter (in)	4, 6, 8, 10, 12	2, 4, 6, 8, 12, 14, 20, 25	1, 2, 3, 4, 5, 6	2, 4	5, 7, 9, 12
Normal Load (lb)	100	198	up to 58	up to 79	up to 279
Height (in)	2.5	varies	1.75	2.5	2.5
Width (in)	varies with diameter	varies with travel	2.63	4.0	8.0
Drive Screw	Worm Gear	Ballscrew, Leadscrew	Leadscrew	Ballscrew	Ballscrew
Lead or Ratio	45:1, 90:1, 180:1	2 mm, 5 mm, 0.1 mm, 0.2 mm	0.025 in, 0.1 in, 0.2 in	2.5 mm, 0.2 in	2.5 mm, 0.2 in, 0.5 in
Bearing Style	Rotary Recirculating	Non-recirculating	Non-recirculating	Non-recirculating	Non-recirculating
Bearing Type	Ball Bearing or Cross Roller	Ball Bearing	Cross Roller	Cross Roller	Cross Roller
Bi-directional Repeatability	18 arc-sec	6 microns	30 microns	6 microns	6 microns
Straightness & Flatness (Precision Option)	(tilt) 40 arc-sec*	2.5 microns per 25 mm N/A	12 microns per 25 mm N/A	2 microns per 25 mm 1 micron per 25 mm	2 microns per 25 mm 1 micron per 25 mm
Covers	N/A	N/A	N/A	Neoprene Bellows	N/A
Motor Type	Stepper or Servo	Stepper or Servo	Stepper or Servo	Stepper or Servo	Stepper or Servo
NEMA Motor Size	23	23	17 or 23	23	23
Encoder Resolution (um)	N/A	5, 1, 0.5, 0.1	1, 2	1, 2	1, 2

* Tilt is measured instead of Straightness and Flatness for RG Rotary Precision Tables.

IDC STAGE DATA

STAGES



STAGE DATA

	RB4A	RB6	RC6	RB8
Type	Linear Axis	Linear Axis	Linear Axis	Linear Axis
Series	High Precision	High Precision	High Precision	High Precision
Travel or Diameter (in)	2, 4, 6, 8, 12, 16	6, 12, 18, 24, 30, 36, 42, 48	6, 12, 18, 24, 30, 36, 42, 48	6, 12, 18, 24, 30, 36, 42, 48, 54, ??
Normal Load (lb)	97	425	425	1250
Height (in)	2.5	3.5	3.5	3.5
Width (in)	4.0	6.0	6.0	8.0
Drive Screw	Ballscrew	Ballscrew	Ballscrew	Ballscrew
Lead or Ratio	2.5 mm, 0.2 in, 0.5 in	0.2 in, 10 mm, 20 mm	0.2 in, 10 mm, 20 mm	0.2 in, 10 mm, 1.0 in
Bearing Style	Recirculating	Recirculating	Recirculating	Recirculating
Bearing Type	Linear Guideway	Linear Guideway	Linear Guideway	Linear Guideway
Bi-directional Repeatability	6 microns	6 microns	6 microns	6 microns
Straightness & Flatness (Precision Option)	2 microns per 25 mm 1 micron per 25 mm	2 microns per 25 mm 1 micron per 25 mm	2 microns per 25 mm 1 micron per 25 mm	2 microns per 25 mm 1 micron per 25 mm
Covers	Neoprene Bellows	Neoprene Bellows	Aluminum Plate	Neoprene Bellows
Motor Type	Stepper or Servo	Stepper or Servo	Stepper or Servo	Stepper or Servo
NEMA Motor Size	23	23 or 34	23 or 34	34
Encoder Resolution (um)	1, 2	1, 2	1, 2	1, 2

IDC XYRB



Features

- Low profile, monolithic design
- Precision crossed roller for high stiffness
- High speed, precision ground ballscrews
- Travels from 2" 2" to 10" x 10"
- Stage limits adjustable to any range of motion

IDC XYRB CROSSED ROLLER BALLSCREW STAGE

IDC XYRB crossed roller stages are low profile stages designed for a wide range of applications. Common uses include factory automation, microelectronics assembly, and laser machining. These tables use 3 mm crossed roller ways and provide high stiffness. Precision ground preloaded ballscrews allow higher speeds speeds with excellent repeatability.

The XYRB stages are built using a monolithic, three piece design which precisely locates the critical duplex and radial bearing journals within the massive center section. This design results in the lowest profile available for an X-Y table (4.0"), and "machined-in" orthogonality, which is determined solely by the center section machining.

Both motors are mounted to the center section and move with the lower axis. Pinch cover protection is also standard, eliminating any safety concerns. Motors, couplings, adjustable hall-effect limits, and locking connectors are included. Standard travels range from 2" x 2" to 10" x 10".

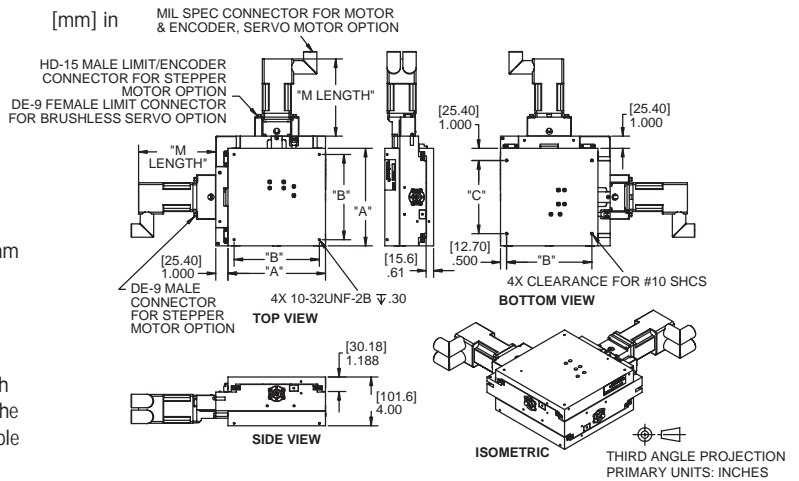

Model	A	B	C	Motor Options	M Length
XYRB-4040	4.00	3.00	2.00	Stepper	
XYRB-6060	6.00	5.00	4.00	150 oz-in, 200 step/rev	6.27
XYRB-8080	8.00	7.00	6.00	150 oz-in, 200 step/rev w/Brake	8.05
XYRB-1010	10.00	9.00	8.00	118 oz-in, 400 step/rev	5.45
XYRB-1212	12.00	11.00	10.00	118 oz-in, 400 step/rev w/Brake	7.23
				Brushless Servo	6.34
				Brushless Servo w/Brake	8.12

SPECIFICATIONS

	XYRB-4040	XYRB-6060	XYRB-8080	XYRB-1010	XYRB-1212
SPECIFICATIONS					
Travel (in)	2 x 2	4 x 4	6 x 6	8 x 8	10 x 10
Overall Height (in)	4.0	4.0	4.0	4.0	4.0
Accuracy (microns)	13	15	20	25	30
Bi-directional Repeatability (microns)	1.0	1.0	1.0	1.0	1.0
Load Capacity (kg)	25	35	50	75	80
Axial Load Capacity (kg)①	20	20	20	20	20
Moment Load Capacity (N-m)②	19	25	34	42	53
Moving Mass					
Upper Axis (kg)	0.5	1.0	1.7	2.5	3.6
Lower Axis (kg)	3.4	6.3	9.2	14.1	20.0
Total Mass (kg)	3.9	7.3	10.9	16.6	23.6
Pitch & Yaw (arc-seconds)③	< 20	< 25	< 30	< 35	< 40
Flatness & Straightness (microns)③	6	8	10	12	14
Orthogonality (arc seconds)	20	20	20	20	20
OPTIONS					
Ballscrew Lead (mm)	2, 5	2, 5	2, 5	2, 5	2, 5
Motor Stepper (oz-in, 200 step/rev)	150	150	150	150	150
Motor Stepper (oz-in, 400 step/rev)	118	118	118	118	118
Motor Servo, Brushless (oz-in)	61	61	61	61	61
Brake	Optional	Optional	Optional	Optional	Optional
Encoder Stepper (cts/rev)④	2000, 4000	2000, 4000	2000, 4000	2000, 4000	2000, 4000

① Upper axis only.
 ② Calculated from centerline of stage table.
 ③ With nominal 2 kg payload.
 ④ Servo motor 2048 cts/rev std.

IDC RBS



IDC RBS BALLSCREW SHUTTLE STAGE

IDC RBS ballscrew driven stages are a companion line to our SAS™ linear motor stages. Both lines share a common base, bearing guideways, and moving carriage. The principal difference is the actuator; RBS stages employ precision ground ballscrews while SAS stages incorporate linear motors.

RBS stages offer significant mechanical advantages and are better in applications where larger payloads and/or axial forces are present. These include vertically oriented applications for which an optional motor-mounted brake is available.

The ballscrew is available with leads of 2 mm, 5 mm, and 10 mm, providing a wide range of linear resolutions and speeds. The inherent symmetry of its center-mounted design avoids the offset torques present in side-driven stages. Flexible bellows are a standard feature and protect the guideways and ballscrew from environmental dirt and debris. With its compact, 3" x 8" cross-section and space-saving recirculating shuttle design, RBS stages combine high performance positioning with a minimal footprint.

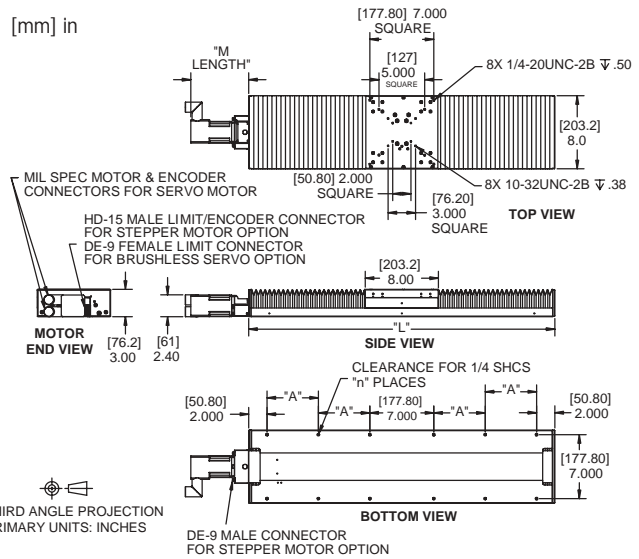

Model	Travel	Length	N	A	Motor Options	M Length
RBS-800	8.00	22	8		Stepper	
RBS-1200	12.00	26	8		150 oz-in, 200 step/rev	6.27
RBS-1800	18.00	32.5	12	7.625	150 oz-in, 200 step/rev w/Brake	8.05
RBS-2400	24.00	39.5	12	9.125	118 oz-in, 400 step/rev	5.45
					118 oz-in, 400 step/rev w/Brake	7.23
					Brushless Servo	6.34
					Brushless Servo w/Brake	8.12
					High Torque Brushless Servo	8.18
					High Torque Brushless Servo w/Brake	9.96

SPECIFICATIONS

	RBS-800	RBS-1200	RBS-1800	RBS-2400
SPECIFICATIONS				
Travel (in)	8	12	18	24
Overall Height (in)	3.0	3.0	3.0	3.0
Accuracy (microns)	9.0	12.0	18.0	24.0
Bi-directional Repeatability (microns)	1.0	1.0	1.0	1.0
Load Capacity (kg)	75	75	75	75
Axial Load Capacity (kg)	35	35	35	35
Moment Load Capacity (N-m) ^①	90	90	90	90
Moving Mass (kg)	5.0	5.0	5.0	5.0
Total Mass (kg)	18	21	25	30
Pitch & Yaw (arc-seconds) ^②	< 15	< 20	< 35	< 30
Flatness & Straightness (microns) ^②	5	7	10	15
OPTIONS				
Ballscrew Lead (mm)	2, 5, 10	2, 5, 10	2, 5, 10	2, 5, 10
Motor Stepper (oz-in, 200 step/rev)	150	150	150	150
Motor Stepper (oz-in, 400 step/rev)	118	118	118	118
Motor Servo, Brushless (oz-in)	61, 192	61, 192	61, 192	61, 192
Brake	Optional	Optional	Optional	Optional
Encoder Stepper (cts/rev) ^③	2000, 4000	2000, 4000	2000, 4000	2000, 4000

① Calculated from centerline of stage table.

② With nominal 2 kg payload.

③ Servo motor 2048 cts/rev std.



IDC FM HEAVY DUTY BALLSCREW STAGE

IDC FM tables are ideal for applications requiring low angular errors and high speeds. This unit utilizes precision ground interface surfaces and crossed roller ways to achieve exceptionally low angular errors and high stiffness. Its center-driven ballscrew design allows speeds to 500 mm/second, and the stage cross-section is only 3 inches high. The inherent symmetry of its center-driven design avoids offset torques that can be created by side-driven stages. Convenient ballscrew access makes servicing easy, and a way cover provides pinch point protection, eliminating any safety concerns. These units include a motor with coupling, Hall-effect limit sensors, and locking motor and limit/encoder connectors with strain-relieved cables. FM stages are an ideal choice for automation and inspection systems, disk drive testing, and laser machining applications.

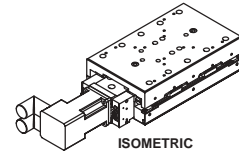
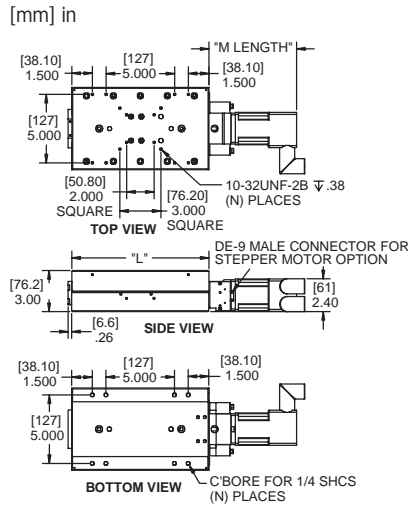

ISOMETRIC
HD-15 MALE LIMIT/ENCODER CONNECTOR FOR STEPPER MOTOR OPTION
DE-9 FEMALE LIMIT CONNECTOR FOR BRUSHLESS SERVO OPTION

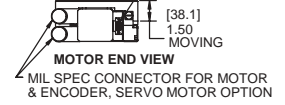

MOTOR END VIEW
MIL SPEC CONNECTOR FOR MOTOR & ENCODER, SERVO MOTOR OPTION
THIRD ANGLE PROJECTION
PRIMARY UNITS: INCHES

Model	Travel	L	N
FM-400	4	8.00	4
FM-600	6	10.00	8
FM-800	8	12.00	8

Motor Options	M Length
Stepper	
150 oz-in, 200 step/rev	6.27
150 oz-in, 200 step/rev w/Brake	8.05
118 oz-in, 400 step/rev	5.45
118 oz-in, 400 step/rev w/Brake	7.23
Brushless Servo	6.34
Brushless Servo w/Brake	8.12
High Torque Brushless Servo	8.18
High Torque Brushless Servo w/Brake	9.96

SPECIFICATIONS

	FM-400	FM-600	FM-800
SPECIFICATIONS			
Travel (in)	4	6	8
Overall Height (in)	3.0	3.0	3.0
Accuracy (microns)	8	12	16
Bi-directional Repeatability (microns)	1.0	1.0	1.0
Load Capacity (kg)	125	150	185
Axial Load Capacity (kg)	38	38	38
Moment Load Capacity			
Pitch (N-m)①	100	117	123
Roll (N-m)①	48	62	79
Moving Mass (kg)	0.7	0.9	1.1
Moving Mass (kg)	2.7	3.2	3.6
Total Mass (kg)	6.4	8.2	10.0
Pitch & Yaw (arc-seconds)②	< 10	< 15	< 20
Flatness & Straightness (microns)②	4	6	8
Maximum Ballscrew Speed (rps)	50	50	50
OPTIONS			
Ballscrew Lead (mm)	2, 5	2, 5	2, 5
Motor Stepper (oz-in, 200 step/rev)	150	150	150
Motor Stepper (oz-in, 400 step/rev)	118	118	118
Motor Servo, Brushless (oz-in)	61, 192	61, 192	61, 192
Brake	Optional	Optional	Optional
Encoder Stepper (cts/rev)③	2000, 4000	2000, 4000	2000, 4000

① Calculated from centerline of stage table.
 ② With nominal 2 kg payload.
 ③ Servo motor 2048 cts/rev std.

IDC LMB

STAGES



IDC LMB BALLSCREW STAGE

The LMB ballscrew driven positioner is a high performance variant of our popular LM stage, and shares many of its features. These include a compact 2.5" high x 4.0" wide cross-section, as well as base and table mounting hole locations. The principal difference lies in the LMB's incorporation of a precision ground ballscrew as the linear actuator. This delivers a substantial increase in the top speed of the stage, as well as higher acceleration capability. As a result, the LMB series is well suited to applications that seek to maximize throughput (moves per second), and it permits much higher duty cycles than conventional friction screw designs. The centered leadscrew also avoids the offset torques common to stages with side-mounted screws.

The precision ground ballscrew provides higher axial stiffness, as does the high capacity duplex angular contact bearing, resulting in a high natural frequency and excellent servo bandwidth capability. The LMB stage is ideal for vertical orientations for which an optional motor mounted brake is available to prevent back driving. LMB stages feature a monolithic design which machines the critical guideway surfaces and leadscrew bearing bores into a single base, maintaining accurate

alignment throughout the service life. Any two LMB stages can be bolted directly together to form an X-Y configuration without the need for adapter plates. The LMB series is available in travels from 2" to 10" in 2" increments.

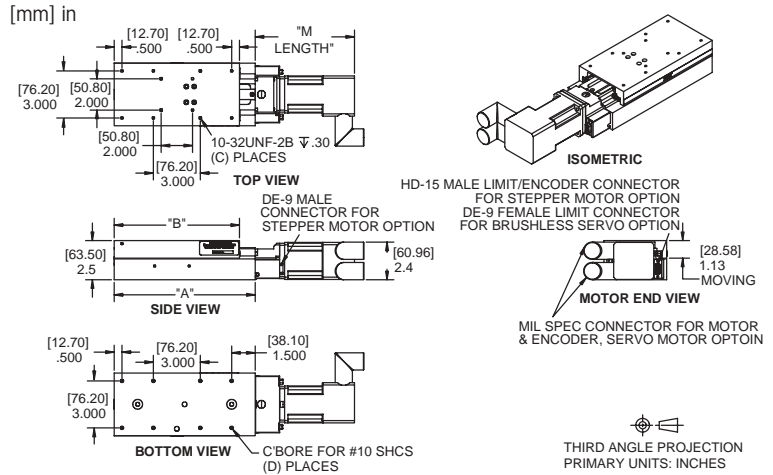

Model	Travel	A	B	C	D	Motor Options	M Length
LMB-200	2	5.00	4.00	8	4	Stepper	
LMB-400	4	7.00	6.00	12	8	150 oz-in, 200 step/rev	6.27
LMB-600	6	9.00	8.00	12	8	150 oz-in, 200 step/rev w/Brake	8.05
LMB-800	8	11.00	10.00	12	8	118 oz-in, 400 step/rev	5.45
LMB-1000	10	13.00	12.00	12	8	118 oz-in, 400 step/rev w/Brake	7.23
						Brushless Servo	6.34
						Brushless Servo w/Brake	8.12

SPECIFICATIONS

	LMB-200	LMB-400	LMB-600	LMB-800	LMB-1000
SPECIFICATIONS					
Travel (in)	2	4	6	8	10
Overall Height (in)	2.5	2.5	2.5	2.5	2.5
Accuracy (microns)	13	15	20	25	30
Bi-directional Repeatability (microns)	1.0	1.0	1.0	1.0	1.0
Load Capacity (kg)	25	35	50	75	80
Axial Load Capacity (kg)	20	20	20	20	20
Moment Load Capacity					
Pitch (N-m)①	56	68	68	68	76
Roll (N-m)①	20	27	35	44	55
Moving Mass	0.5	0.7	0.9	1.1	1.4
Total Mass (kg)	2.5	3.2	3.9	4.6	5.2
Pitch & Yaw (arc-seconds)②	< 15	< 20	< 25	< 30	< 35
Flatness & Straightness (microns)②	5	6	8	10	12
OPTIONS					
Ballscrew Lead (mm)	2, 5	2, 5	2, 5	2, 5	2, 5
Motor Stepper (oz-in, 200 step/rev)	150	150	150	150	150
Motor Stepper (oz-in, 400 step/rev)	118	118	118	118	118
Motor Servo, Brushless (oz-in)	62	62	62	62	62
Brake	Optional	Optional	Optional	Optional	Optional
Encoder Stepper (cts/rev)③	2000, 4000	2000, 4000	2000, 4000	2000, 4000	2000, 4000

① Calculated from centerline of stage table.
 ② With nominal 2 kg payload.
 ③ Servo motor 2048 cts/rev std.

IDC SAS



IDC SAS LINEAR MOTOR SHUTTLE STAGE

SAS single-axis shuttle stages provide high speed in a very compact design. The stage design uses recirculating bearings to minimize the overall moving envelope. Its brushless linear servo motor allows high speeds with smooth positioning, making it ideal for use in high throughput applications.

Two types of linear motors are available; the SAS-IC stages incorporate ironcore motors while the SAS-IL stages use ironless motors. Each one provides characteristics that are optimal depending on the application. Iron core motors, which have their coils wound on steel laminates, maximize force with a single-sided magnet way. Their high thrust force makes them ideal for accelerating and moving large masses and maintaining position during process forces. Ironless motors have no ferrous material in their coil assemblies, therefore, these motors have zero cogging and no attractive forces between the coil and the magnetic way. These motor characteristics make them ideal for applications which require constant velocity control.

A linear encoder is standard and available in two resolutions. The bearings and lubricants have been optimized for a low and uniform coefficient of friction. Standard units include flexible bellows. The unit's cabling terminates on a static base plate, simplifying external wiring for convenient integration.

Vacuum and signal lines can also be made available on the stationary base plate, and routed to the top plate. These units can be stacked into an X-Y configuration with 15 arc-second orthogonality.

[mm] in

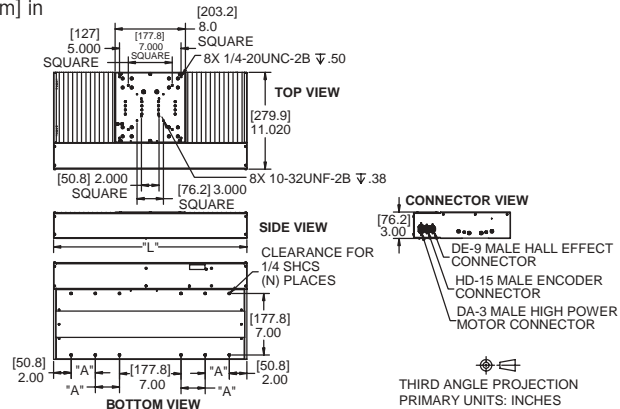

Model	Travel	Length	N	A
SAS-800	8.00	22	8	
SAS-1200	12.00	26	8	
SAS-1800	18.00	32.5	8	7.375
SAS-2400	24.00	39.5	12	9.125
SAS-3600	36.00	53	12	12.5

SPECIFICATIONS

	SAS-IC-800	SAS-IC-1200	SAS-IC-1800	SAS-IC-2400	SAS-IC-3600	SAS-IL-800	SAS-IL-1200	SAS-IL-1800	SAS-IL-2400	SAS-IL-3600
Travel (in)	8	12	18	24	36	8	12	18	24	36
Overall Height (in)	3.0	3.0	3.0	3.0	3.0	3.0	3.0	3.0	3.0	3.0
Positional Accuracy (microns)	6	9	11	13	21	6	9	11	13	21
Resolution (microns)	1.0, 0.5	1.0, 0.5	1.0, 0.5	1.0, 0.5	1.0, 0.5	1.0, 0.5	1.0, 0.5	1.0, 0.5	1.0, 0.5	1.0, 0.5
Bi-directional Repeatability	±1 count	±1 count	±1 count	±1 count	±1 count	±1 count	±1 count	±1 count	±1 count	±1 count
Load Capacity (kg)	75	75	75	75	75	75	75	75	75	75
Moment Load Capacity (N·m) ^①	90	90	90	90	90	90	90	90	90	90
Maximum Acceleration (m/s ²) ^②	50	50	50	50	50	40	40	40	40	40
Maximum Velocity (m/s) ^②	3	3	3	3	3	3	3	3	3	3
Moving Mass (kg)	6.6	6.6	6.6	6.6	6.6	5.2	5.2	5.2	5.2	5.2
Total Mass (kg)	20	23	27	32	38	18	21	25	30	36
Pitch & Yaw (arc-seconds)	15	20	25	30	50	15	20	25	30	50
Flatness & Straightness (microns)	3	5	9	13	30	3	5	9	13	30
Motor Force Constant (N/A)	44.6	44.6	44.6	44.6	44.6	16.9	16.9	16.9	16.9	16.9
Fundamental Motor Constant (N/√W)	20.5	20.5	20.5	20.5	20.5	6.6	6.6	6.6	6.6	6.6
Back-emf Constant (V/m/s)	42.0	42.0	42.0	42.0	42.0	13.8	13.8	13.8	13.8	13.8
Coil Resistance (25°C, ohm)	3.0	3.0	3.0	3.0	3.0	3.1	3.1	3.1	3.1	3.1
Coil Inductance (mH)	9.7	9.7	9.7	9.7	9.7	0.65	0.65	0.65	0.65	0.65
Continuous Current (amps)	2.0	2.0	2.0	2.0	2.0	2.6	2.6	2.6	2.6	2.6
Peak Current (amps)	13.7	13.7	13.7	13.7	13.7	14.2	14.2	14.2	14.2	14.2
Continuous Force (N)	120	120	120	120	120	46	46	46	46	46
Peak Force (N)	560	560	560	560	560	240	240	240	240	240
Continuous Power Rating (watts)	35	35	35	35	35	65	65	65	65	65

① Calculated from centerline of stage table.

② Maximum speed and acceleration are load and encoder dependent.

IDC MAG

STAGES



IDC MAG LINEAR MOTOR STAGE

The MAG linear motor stage is a very compact, high performance, direct drive table suitable for use in applications that require high accelerations as well as high performance scanning. The product line has been designed in two versions, the MAG-IC stage, which is best suited for high acceleration point-to-point type moves, and the MAG-IL stage, which is suited for constant velocity applications.

Cross-sections for both MAG-IC and MAG-IL stages are identical at 50 mm tall x 150 mm wide. Any two versions will bolt directly together to form a very stiff, compact X-Y assembly, without the need of adapter plates. MAG stages employ a moving magnet design, which locates all cables and connectors in the stationary base. The absence of any moving cables eliminates motion errors due to cable forces. The precision ground cross roller ways provide high stiffness together with smooth motion, and are capable of supporting torques due to offset loads. Cage creep is eliminated through the use of geared anti-creep cage assemblies.

Two types of linear motors are available; the MAG-IC stages incorporate iron core motors while the MAG-IL stages use ironless motors. Each one

provides characteristics that are optimal depending on the application. Iron core motors, which have their coils wound on steel laminates, maximize force with a single-sided magnet way. Their high thrust force makes them ideal for accelerating and moving large masses and maintaining position during process forces. Ironless motors have no ferrous material in their coil assemblies, therefore, these motors have zero cogging and no attractive forces between the coil and the magnetic way. These motor characteristics make them ideal for applications which require constant velocity control.

The built-in non-contact encoder is available with resolutions of 1.0 micron and 0.5 micron. This encoder plugs directly into Kollmorgen CD and PD products for a complete staging and controller solution, and are available in standard travels of 50 through 250 millimeter in 50 millimeter increments.

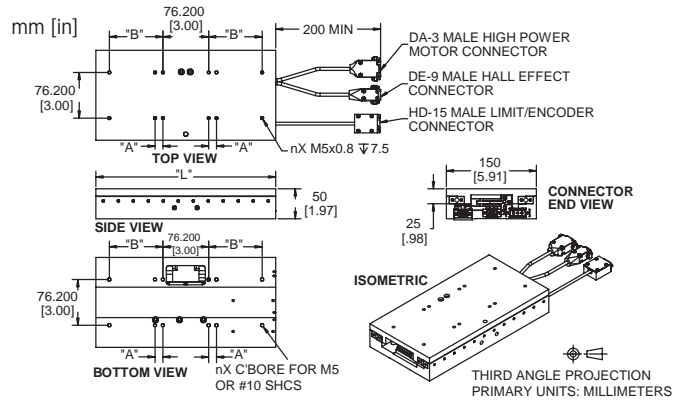

Model	Travel	Length	A	B	N
MAG-50	50 (1.97)	200 (7.87)			8
MAG-100	100 (3.94)	250 (9.80)			8
MAG-150	150 (5.91)	300 (11.81)			8
MAG-200	200 (7.87)	350 (13.78)	55.95 (2.20)	114.3 (4.5)	12
MAG-250	250 (9.84)	400 (15.75)	68.75 (2.71)	125.0 (4.92)	12

SPECIFICATIONS

	MAG-IC-50	MAG-IC-100	MAG-IC-150	MAG-IC-200	MAG-IC-250	MAG-IL-50	MAG-IL-100	MAG-IL-150	MAG-IL-200	MAG-IL-250
Travel (in)	50	100	150	200	250	50	100	150	200	250
Overall Height (in)	50.0	50.0	50.0	50.0	50.0	50.0	50.0	50.0	50.0	50.0
Accuracy (microns)	3	5	8	10	12	3	5	8	10	12
Resolution (microns)	1.0, 0.5	1.0, 0.5	1.0, 0.5	1.0, 0.5	1.0, 0.5	1.0, 0.5	1.0, 0.5	1.0, 0.5	1.0, 0.5	1.0, 0.5
Bi-directional Repeatability	±1 count	±1 count	±1 count	±1 count	±1 count	±1 count	±1 count	±1 count	±1 count	±1 count
Load Capacity (kg)	35	40	50	65	75	35	40	50	65	75
Moment Load Capacity										
Pitch (N-m) ^①	25	36	47	58	67	25	36	47	58	67
Roll (N-m) ^①	67	73	79	85	92	67	73	79	85	92
Maximum Acceleration (m/s ²) ^②	50	50	50	40	30	30	25	20	18	15
Maximum Velocity (m/s) ^②	3	3	3	3	3	3	3	3	3	3
Moving Mass (kg)	2.4	2.7	3.0	4.0	5.0	3.3	4.1	5.0	5.8	6.6
Total Mass (kg)	3.8	4.8	5.5	6.5	9.0	4.9	5.7	7.2	8.4	9.5
Pitch & Yaw (arc-seconds)	10	15	20	25	25	10	15	20	25	25
Flatness & Straightness (microns)	4	5	7	9	11	4	5	7	9	11
Motor Force Constant (N/A)	26.7	26.7	26.7	26.7	26.7	16.8	16.8	16.8	16.8	16.8
Fundamental Motor Constant (N/√W)	10.0	10.0	10.0	10.0	10.0	4.7	4.7	4.7	4.7	4.7
Back-emf Constant (V/m/s)	22	22	22	22	22	13.7	13.7	13.7	13.7	13.7
Coil Resistance (25°C, ohm)	3.2	3.2	3.2	3.2	3.2	6.1	6.1	6.1	6.1	6.1
Coil Inductance (mH)	9.1	9.1	9.1	9.1	9.1	1.3	1.3	1.3	1.3	1.3
Continuous Current (amps)	2.0	2.0	2.0	2.0	2.0	1.3	1.3	1.3	1.3	1.3
Peak Current (amps)	7.9	7.9	7.9	7.9	7.9	7.1	7.1	7.1	7.1	7.1
Continuous Force (N)	40	40	40	40	40	27	27	27	27	27
Peak Force (N)	170	170	170	170	170	120	120	120	120	120
Continuous Power Rating (watts)	15	15	15	15	15	32.5	32.5	32.5	32.5	32.5

① Calculated from centerline of stage table.

② Maximum speed and acceleration are load and encoder dependent.

IDC DRT-100

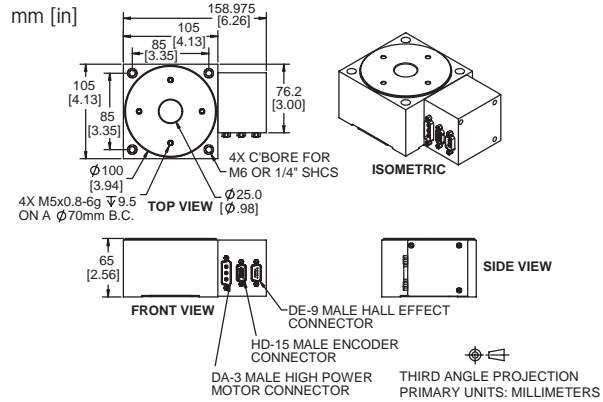

IDC DRT-100 DIRECT DRIVE ROTARY STAGE

IDC's DRT-100 Rotary Stage is a compact, direct drive rotary table that establishes a new level of price, performance, and compactness. Its direct drive technology eliminates the gear wear, torque variations, and backlash conventional rotary tables encounter. Speed, resolution, and repeatability are also increased by a factor of ten or more over gear driven rotary tables. Despite its high level of performance, the DRT-100 Stage is very compact, with body dimensions of 105 mm x 105 mm x 65 mm. Its 25 mm through-bore allows convenient routing of optical beam paths or vacuum/pneumatic lines.

The DRT-100 Table offers a standard resolution of 20 micro-radians (~4 arc-seconds, or 0.0011°); due to its direct drive technology, the repeatability is +/- 1 count, or +/- 20 micro-radians. Speeds to 10 revolutions per second, and accelerations to 400 revolutions per second², permit rapid point-to-point moves. Settling times are minimized due to the direct drive design, which allows high servo bandwidths. Unlike other direct drive rotary tables, the electronic interface is completely standard, with digital A Quad B encoder outputs, a standard three phase brushless motor, and three digital Hall commutation sensors. This allows the DRT-100 Stage to be driven by any commercial motion controller/amplifier that can drive standard three phase brushless motors. The 4 point contact ball bearing provides a high degree of axial and torsional stiffness, and a once per revolution index sensor allows a unique home location to be defined.

SPECIFICATIONS

Table Diameter (mm)	100
Through-bore Diameter (mm)	25
Accuracy - uncompensated (micro-radians (arc-seconds))	± 875 (± 180)
Accuracy - compensated (micro-radians (arc-seconds))	± 88 (± 18)
Resolution (micro-radians (arc-seconds))	20 (4)
Bi-directional Repeatability (micro-radians)	± 20
Maximum Speed (rev/sec (MHz))	10 (3.15)
Maximum Acceleration (rev/sec ²) ^①	400
Axial Motion (microns)	< 5
Radial Motion (microns)	< 5
Tilt Motion (micro-radians)	< 100
Axial Load Capacity (N)	400
Radial Load Capacity (N)	200
Moment Load Capacity (N-m) ^②	5
Axial Stiffness (N/m)	0.9 x 10 ⁷
Radial Stiffness (N/m)	0.9 x 10 ⁷
Torsional Stiffness (N-m/radian)	8.0 x 10 ⁴
Total Mass (kg)	2.3
Rotational Inertia (kg-m ²)	8.85 x 10 ⁻⁴
Torque Constant (N-m/amp)	0.49
Motor Constant (N-m/√watt)	0.16
Back-emf Constant (V/rev/sec)	0.42
Coil Resistance (ohms)	6.92
Coil Inductance (mH)	7.5
Continuous Current (amps)	2.4
Peak Current (amps)	6.5
Motor Continuous Torque (N-m)	1.00
Motor Peak Torque (N-m)	2.73
Bearing Torque (N-m)	0.23
Available Continuous Torque (N-m)	0.77
Available Peak Torque (N-m)	2.5

① Maximum speed and acceleration are load and encoder dependent.

② Calculated from centerline of stage table.

IDC DRT-200

STAGES

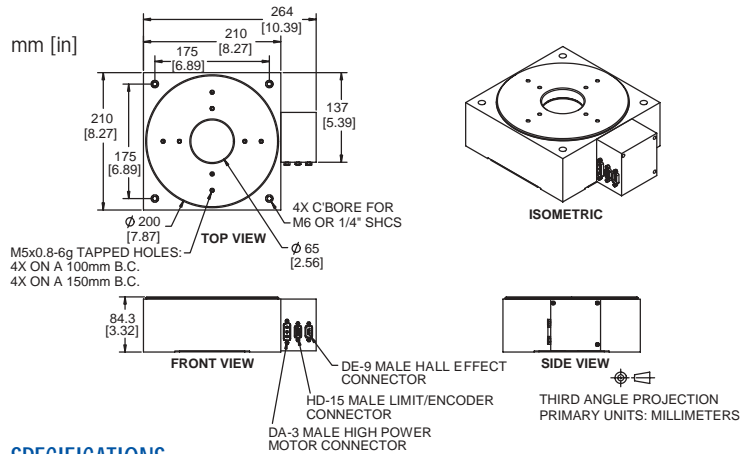

IDC DRT-200 DIRECT DRIVE ROTARY STAGE

IDC's DRT-200 stage is a high torque, direct drive rotary table that establishes a new level of price, performance, and compactness. Its direct drive technology eliminates the gear wear, torque variations, and backlash found in conventional rotary tables. Speed, resolution, and repeatability are also increased by a factor of ten or more over gear driven tables. Despite its high level of performance, the DRT-200 stage has a lower profile than competing tables, with body dimensions of 210 mm x 210 mm x 84.3 mm. Its 65 mm through-bore allows convenient routing of optical beam paths or vacuum/pneumatic lines. In comparison to our popular DRT-100 rotary table, the DRT-200 stage offers substantially higher peak and continuous torque. Its large diameter, four-point contact main bearing provides increased load capacity and increased axial and torsional stiffness.

The DRT-200 table offers a standard resolution of 10 micro-radians (~2 arc-seconds, or 0.00051°); due to its direct drive technology, the repeatability is +/- 1 count, or +/- 10 micro-radians. Speeds to 6 revolutions per second, and accelerations to 400 revolutions per second², permit rapid point-to-point moves. Settling times are minimized due to the direct drive design, which allows high servo bandwidths. Unlike many commercial direct drive rotary tables, the electronic interface is completely standard, with digital A Quad B encoder outputs, a standard three phase brushless motor, and three digital Hall commutation sensors. This allows the DRT-200 stage to be driven by any commercial motion controller/amplifier that can drive standard three phase brushless motors. The DRT-200 table is an excellent match for our SERVOSTAR® CD amplifiers, which close fully digital position, velocity, and current loops, and extract maximum performance from this direct drive rotary table.

SPECIFICATIONS

Table Diameter (mm)	200
Through-bore Diameter (mm)	65
Accuracy - uncompensated (micro-radians (arc-seconds))	± 875 (± 180)
Accuracy - compensated (micro-radians (arc-seconds))	± 88 (± 18)
Resolution (micro-radians (arc-seconds))	10 (2)
Bi-directional Repeatability (micro-radians)	± 10
Maximum Speed (rev/sec (MHz))	6 (3.15)
Maximum Acceleration (rev/sec ²) ^①	400
Axial Motion (microns)	< 5
Radial Motion (microns)	< 5
Tilt Motion (micro-radians)	< 100
Axial Load Capacity (N)	980
Radial Load Capacity (N)	490
Moment Load Capacity (N-m) ^②	145.0
Axial Stiffness (N/m)	2.0 x 10 ⁶
Radial Stiffness (N/m)	3.2 x 10 ⁷
Torsional Stiffness (N-m/radian)	5.0 x 10 ⁴
Total Mass (kg)	7.9
Rotational Inertia (kg-m ²)	9.44 x 10 ⁻³
Torque Constant (N-m/amp)	1.09
Motor Constant (N-m/√watt)	0.66
Back-emf Constant (V/rev/sec)	0.14
Coil Resistance (ohms)	2.8
Coil Inductance (mH)	13.0
Continuous Current (amps)	6.2
Peak Current (amps)	48.0
Motor Continuous Torque (N-m)	6.5
Motor Peak Torque (N-m)	27.7
Bearing Torque (N-m)	0.79
Available Continuous Torque (N-m)	5.7
Available Peak Torque (N-m)	26.9

① Maximum speed and acceleration are load and encoder dependent.

② Calculated from centerline of stage table.