



PHARMA SERIES

PHARMACEUTICAL SHRINK BUNDLER. The PHARMA series shrink bundlers are compact, intermittent motion machines designed to collate and shrink wrap pharmaceutical products. This Polypack model uses a motorized pusher to provide smooth, positive transfers. This pharmaceutical shrink wrapper is capable of handling both rounded and squared containers, such as vitamin bottles and small cartons. These compact bundlers are ideal for nutraceutical, pharmaceutical, and personal care products.

POLYPACK'S PHARMA SERIES integrates state of the art design, construction, operation and safety features. These machines are designed to respond to the needs of the pharmaceutical and nutraceutical industries. These machines are very compact and can multipack small bottles, vials, medicine boxes, medical tubes, and other medical, pharmaceutical and nutraceutical packages of different shapes and sizes.



**WE GOT IT
COVERED**



PHARMA SERIES

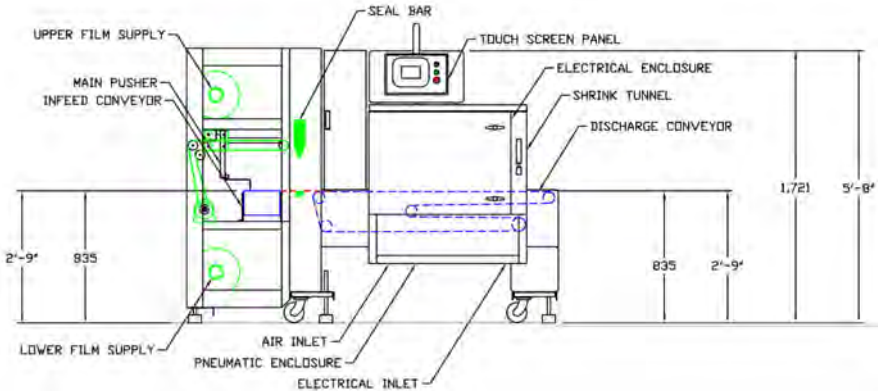
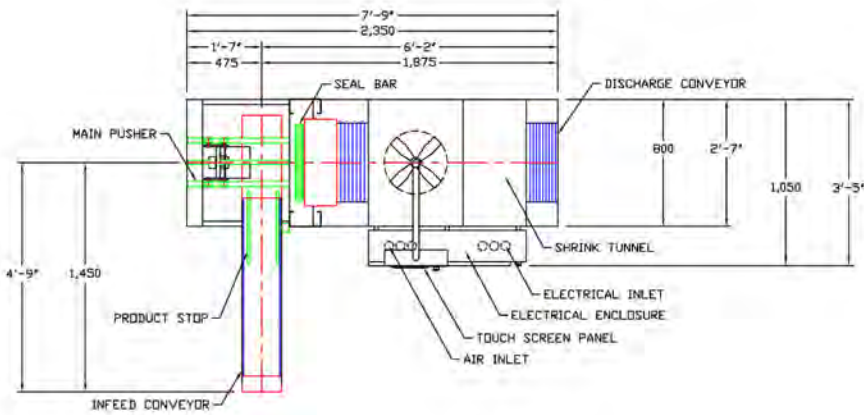

PHARMA SERIES MACHINE FEATURES

- *Heavy Gauge, Stainless Steel Construction
- *Self-Leveling, Teflon[®] Coated Hot Knife Sealbar Assembly
- *Pre-Programmed Collation Modules
- *Self-Adjusting Solid Stainless Steel Rod Tunnel Conveyor (No Belts or Coatings)
- *Engineered as a Single Unit with Integrated Double Insulated Tunnel to Reduce Energy Consumption
- *Polycarbonate Enclosures Ensure Safety and Easy Access to Machine Components
- *Quick, Tool-Free Changeovers
- *PLC Touchscreen Interface

MOTION TECHNOLOGIES PTY LTD



24/22-30 Northumberland Road
Caringbah NSW 2229 Australia
Phone: (02) 9524 4782
Fax: (02) 9525 3878

Unit 13/54 Smith Road
Springvale VIC 3171 Australia
Phone: (03) 8555 3586
Fax: (03) 8555 3553

sales@motiontech.com.au

www.motiontech.com.au

© 30/03/16

**WE GOT IT
COVERED**

**poly
pack** inc.

CORPORATE HEADQUARTERS
3301 GATEWAY CENTRE BLVD.
PINELLAS PARK, FL 33782 USA

POLYPACK.COM
INFO@POLYPACK.COM
727.578.5000

