

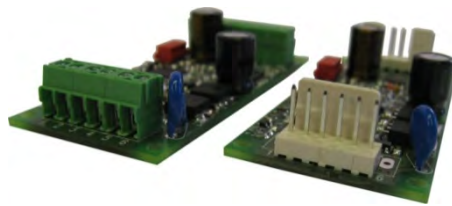

**MOTION TECHNOLOGIES
PTY LTD**

TECHNICAL SPECIFICATIONS ELECTROMEN BRUSH MOTOR POSITIONING CONTROLLERS

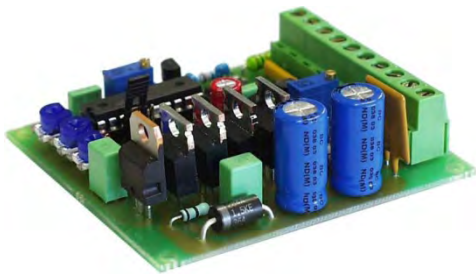

SUMMARY

Continuous Current limit (amps)	Volts	Model #	Command Mode	Page
4	12-24	EM-324-SAF	Analogue	3
4	12-24	EM-324-SPF	Pulse	6
5	12-32	EM-165	Analogue	9
5	12-32	EM-165pf	Pulse	11
4	12-32	EM-143s	Analogue	13
4	12-32	EM-167	Analogue	15
15	12-24	EM-241-SAF	Analogue	17
15	12-24	EM-241-SPF	Pulse	20
12	12-32	EM-160	Analogue	23



Distributors for Australia & New Zealand

MOTION TECHNOLOGIES PTY LTD

24/22-30 Northumberland Road
Caringbah NSW 2229 Australia
Phone: (02) 9524 4782
Fax: (02) 9525 3878

sales@motiontech.com.au
www.motiontech.com.au

© 19/03/19

EM-324-SAF POSITIONING DRIVER 12-24V 4A

FEATURES

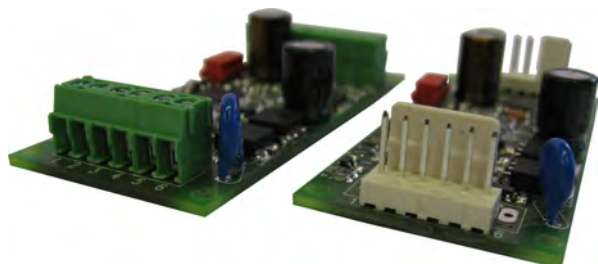

- analog feedback
- multiple dynamic settings
- solid state power stage
- one or two pulse feedback
- voltage or mA control
- position accuracy max. 0.2%
- versatile setting options
- digitally settable parameters
- housing options available
- 2/16kHz pwm frequency options
- CE marked product

EM-324-SAF is a positioning driver to be used with DC-motors. The solid state power stage operates with high efficiency as it is realized with FET-transistors. Its literally everlasting compared to relay solutions. Control and feedback is done with analog signal. Control signal can be a voltage in range of 0 to 11V or current from 0 to 20mA. Feedback signal can be in the range from 0 to 11V. Driver supports also a potentiometer feedback, with auxiliary voltage outputs of 0V and 5,5V to excite the potentiometer. The max. accuracy available for positioning is 0,2% that is adequate for most actuator positioning applications.

The settings and adjustments are done with parameters as in all new generation Electromen products. Movement range can be modified from both ends with SW-limit parameters. Current limits and driving speeds can be set individually for both directions. Driver includes also many other dynamic adjustment possibilities like parameters for load compensation, dead-zone setting (positioning window), start and stop ramps for a smooth direction change and braking zone for well operating positioning.

The parameter setting and status monitoring is done with EM-236 Interface Unit. With EM-236 the right parameters can also be easily copied to other driver units. The on-board LED-light indicates the possible fault situations with blinking codes. If needed, the fault can be forwarded trough combiport to other driver cards. Alternatively this port can be set to give out the "position OK" information or it can even indicate the position with an analog voltage signal. Device is EMC tested for industrial and household environment and operating temperature range is quite wide.

There are also some housing options available for EM-241-SAF driver card.

TECHNICAL DATA

Supply voltage	10-35V
Shut down voltage	8V
Power up voltage	9V
Motor current cont.	4A at 2kHz / 3A at 16kHz mom. 6A (Ta<50°C)
Current limit	0.1-6A (in start max. 8A)
Overtemp. limit	100°C
PWM frequency	2kHz / 16kHz
Analog feedback ranges	0-5V / 0-10V
Control input ranges (position)	0-5,5V / 0-11V / 4-20mA
Positioning potentiometer	10k recom. 22k max.
Input resistor for mA-signal	250ohm (socket on board)
Position out. signal range	0-5V or 0.5 - 4.5V, 0V for FAULT
Digital input levels	high =4-30V, low=0-1V
Digital input impedances	typ. 47kohm
Limit-FW / -BW and pulse inputs	imp. typ 10kohm
COMBIPORT pin.13	
- Fault output, NPN, open coll.	max 30V / 1A
- Disable input	Uin < 1V (NPN)
- position output impedance	1kohm
Connectors for motor and supply	max. 1mm ² cable
Connectors for signals	max. 1mm ² cable
Operating temp(Ta)	-40...60°C
Dimensions	72x32x25mm
Weight	80g
CE-tested for household and industrial environment (EMC)	EN-55022B, EN-61000-4-3, -4, -5, -6 passed

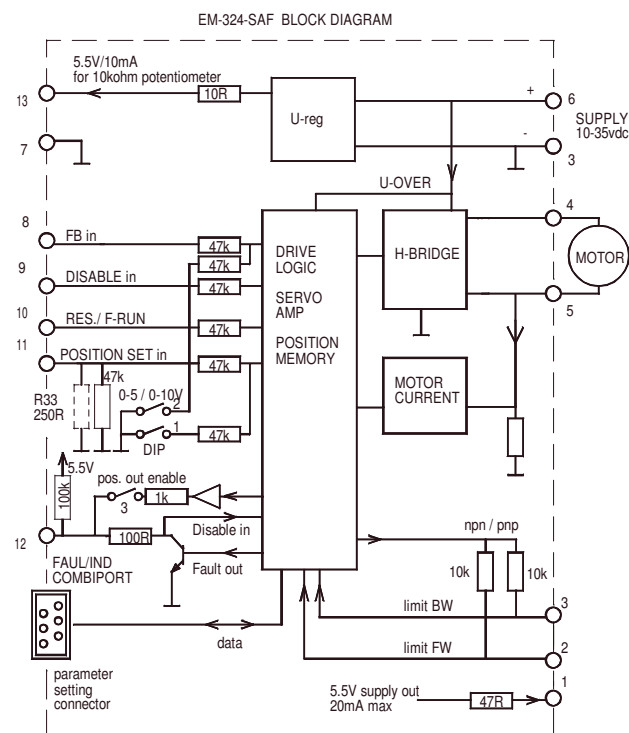

CONNECTION ADVISE

Supply voltage should be in the limits of 10-35Vdc.
Ripple should be lower than 30% even with maximum load.
NOTICES!

1. Wrong supply polarity can damage the device.
2. There is no inbuilt fuse in this device. So use an additive outside fuse and choose it according to your application.
3. The meaning of the terminals can change when changing the parameters (pls.see the parameter list and explanations).

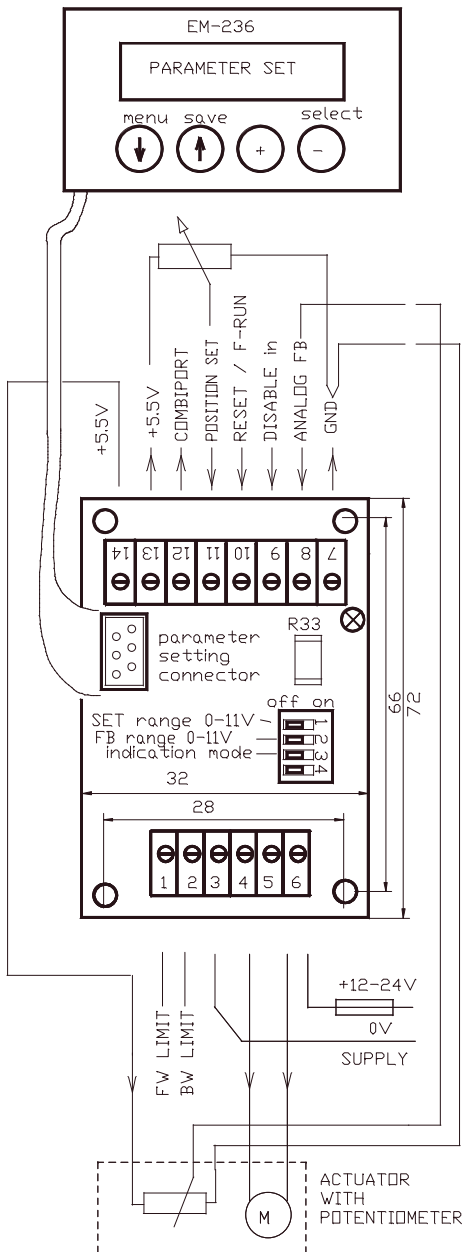

NOTICE !
IF WANT TO USE 4-20mA SET SIGNAL
THEN ADD 250ohm RESISTOR TO
PLACE R33

TAKING IN TO USE

The setting of the driver is done with parameters, and the parameters can be set and edited with EM-236 Interface Unit. This makes changing easy and precise. Also the copying of the same parameters to multiple units is simple and same time accurate. The same parameters that are saved to one unit can be copied to an other unit with just one push of a button.
Start by checking and setting the hardware related parameters. After that the actuator can be connected and operation fine tuned with other parameters.

Control range setting

Options for max. ranges are 0 to 5,5V, and 4 to 20mA if you place a 250ohm resistor to the resistor socket on the driver board. Using 0 to 11V range requires you to set the DIP switch 1 to "ON" position.

An individual control scale you can either set with parameters 21 and 22 as Volts or you can let the driver to measure your min. and max. control values. If you choose to set the min. and max. as Volts, pls. notice that the values are in ratio to the lowest range 0-5,50V, and with 0-11V range you have to divide the actual voltage with two. With current signal you should use the 0-5,5V range, and the right value can be calculated 1×250 . Eg: $4-20mA = 1,0 - 5,0V$. Most precise way is to let the driver to measure the values. So first connect and adjust minimum value to set input (pin.12) and change the par.21 to val. 551. After value stops blinking the display shows the measured value. Then adjust the maximum control value to pin.12, and change par.22 to 551. After a while you will see the measured value in display. Always remember to save with long push to save button, before disconnecting EM-236 and taking power off from the driver.
Notice: If control min. value is set higher than max. value the movement range will be inverted and set accordingly.

Feedback

Feedback range is always 0 to 5,5V as default.
By setting the dip switch 2 to "ON" the range can be multiplied to 0 - 11V.

If the actual feedback signal can not reach the ends of the default range, parameters 23 and 24 can be used to accommodate the ranges. Setting the inner and outer software limits to suitable percentage values will compensate the narrow control signal range to the default range.

Forced run (F-run)

Forced run enables the motor to be driven to the mechanical end. That means that the motor or actuator can be driven beyond the determined software limits. The SW-limits are used to determine the operational movement range. But the parameter 14 value and the use of F-run will enable the wider driving range for service use or for use in some special situations of the application. F-run is started with a long command (>5s) to pin 11. The F-run speed is determined with parameter 5 and the driving is stopped with current trip or limit switch that cuts off the motor current. Motor will return to its servo position right after the signal to pin 11 disappears.
Notice. The same pin 11 is used also as a reset input with short command (<5s).

Positioning dynamics

Dead zone (par.17) is to determine the accuracy of positioning.
This parameter has the major effect to positioning accuracy.

The smaller it is determined the more accurately the positioning is done.
Notice. If it is set too small compared to accuracy level of the mechanics an oscillation or unstability in positioning will occur.

Braking zone (par. 18) is used to optimize the time needed for positioning.
Too high value slows down too early, and too low value will cause an fast position passing and needs a corrective return driving.

Start and stop ramp (par. 19 & 20) are to smoothen the direction change.
Often suitable value for stop ramp is half of start ramp. Too long stop ramp can make the direction change too time consuming and too short can cause mechanical stress and non desired aggressivity.

Load compensation (par.11) when set to right value, will ensure the needed force to start driving and to taking the load in to the right position.
With high load and too low load compensation value, the motor dont have force enough to reach the right position. Start testing with zero value and increase value until motor behaves unstable and twitching. Thumb rule in this point is to decrease the value with 25%.

Current limits (par. 6 and 7)should be set according to the motor nominal max. current or according to the required current of the application.

Indications

Fault situations are indicated with coded blinking of a red LED. Fault alarm can be forwarded out through combiport (pin.13). Fault situation is reset with a short (<5s) command to RES/F-run input (pin.11).

Some faults are reset automatically with a new position command to opposite direction. Instead of fault indication the combiport can be set to inform the status of the positioning as an "on position" output, or it can be set to give an analog position indication with 0-5V or 0.5-4.5V signal. Configuration of the combiport is done with par.9. Notice: If it is set to give analog information out (par.9 val3/4), also the DIP-switch 3 should be set to ON position. If combiport (pin 13) is selected to be fault output (par.9 val.1), it will also work as fault-disable input when externally pulled down.

Adjustments and settings

Parameter setting is done with EM-236 Interface Unit which is connected to a powered controller unit through the red connector. During the start up routine the Interface Unit will display information about itself and then the name and program version of the target device (driver which it was connected to). Then it will stay on displaying EDIT & LOAD. Pushing the "yes" button will upload and show the parameter list of the driver. Now the user can scroll the list with arrows, and make value changes with + and - buttons. Changed value is effective after few seconds when the display stops the blinking. But notice, that the change will not be saved until you give a long press (>5s) with the "save" button. This will save the changed list also to the EM-236s memory. Now it is easy to copy the same parameters to the next driver. Just connect the unit to the next powered driver and after start up routine just press a long "save". You can repeat this until all needed units have been set.

LIST OF PARAMETERS prog. v1.2 (defaults in parentheses)

- 1 No function (0)
- 2 Limit input logic (1)
 - 1= PNP
 - 2= NPN
 - 3= PNP inverted
 - 4= NPN inverted
- 3 Speed FW: 20-100% / 0-100 (100)
- 4 Speed BW: 20-100% / 0-100 (100)
- 5 Speed for F-driving: 20-100% / 20-100 (60)
- 6 Current limit out, FW: 0.1-20A / 1-200 (30)
- 7 Current limit in, BW: 0.1-20A / 1-200 (30)
- 8 Current tripp delay: 0-255ms / 0-255 (20)
(0=tripp not in use)
- 9 Combiport (pin 13) function: 1-4 (1)
 - 1= used as Fault in/out
 - 2= gives the "on position" information with 0V
 - 3= gives position indication with 0 - 5V
 - 4= gives position indication with 0.5-4.5V and fault =0V
- 10 Over voltage limit: 15-40V / 15-40 (35)
- 11 Load compensation: 0-255 / 0-255 (0)
- 12 Time out cut-off: 1-255s. / 1-255 (0= not in use) (0)
- 13 Hour and start counter reset (0)
set value = 1 and press save -> counters are set to zero
- 14 Forced run function with >5s command to pin 11 (1)
 - 1= makes F-run to BW direction
 - 2= makes F-run to FW direction
- 15 Fault reset conditions 0-1 (1)
 - 0= reset with RESET-input or opposite direction request.
 - 1 = fault reset can be done only with RESET-input (pin 11)
- 16 No function (0)
- 17 Dead zone : 0,2-5% / 2-50 (10)
- 18 Braking zone : 1 - 8% / 1 - 8 (3)
- 19 Start ramp : 0,1-2,5s / 0-250 (10)
- 20 Stop ramp : 0,1-2,5s / 0-250 (3)
- 21 Set value min. 0...5,50V / 0-551 (0)
- 22 Set value max. 0...5,50V / 0-551 (550)
- 23 Inner (BW) SW-limit: 0...50% 0-500 (5)
- 24 Outer (FW) SW-limit: 0...+50% 0-500 (5)

FAULT LED -blinking codes

- | | |
|----------------------|----------|
| 1. I-trip | 1 blink |
| 2. time out trip | 2 blinks |
| 3. over temperature | 3 blinks |
| 4. over voltage trip | 4 blinks |

Pls. notice:

when card is powered the LED- blinks onse.

MONITORABLE VALUES

- | | |
|------------------------------------|---------------------------|
| 1 fault code | (see the fault code list) |
| 2 motor current | 0-20A (0-200) |
| 3 target position | 0-100,0% (0-1000) |
| 4 realized position | 0-100,0% (0-1000) |
| 5 hour counter | (max.65535h) |
| 6 start counter | (max.65535 starts) |
| 7 start counters over flow counter | (max. 65535) |

ABOUT PARAMETERS

- 1. No function.
 - This parameter position is not in use in this program.
- 2 Limit switch input terminals (pin 2 and 3) can be set to work with positive or negative logic. Positive =PNP, negative=NPN. The effect can also be inverted so that when signal is ON status is OK, and signal OFF status is "disable by limit".
- 3 & 4 are for speed setting of FW (out) and BW (in) directions.
- 5 the speed setting for "Forced run" (F-run).
- 6 & 7 current limit setting for FW (out) and BW (in) directions
- 8 determines the time the current is allowed to be on the limit value before driving is cut off (driver trips off). Value is in milliseconds and if set to "0", the current tripping feature is disabled.
- 9 Configuring the combiport functions (pin 13). This terminal can work as combined input-output for fault. Or it can give a "position OK" signal after successful positioning. It can also be used to indicate the position with a continuous voltage signal (position signal). If position signal is chosen (val 2 or 3) the DIP3 must be set to "ON".
- 10 Over voltage protection switches the motor to free wheel. This saves the controller or other devices in supply line from over voltage in case the motor generates energy during slowing down or braking. This can happen with eg. in vehicle or lifting applications.
- 11 Load compensation (Rxl-comp) enables good motor torque even with low speeds. It is good to start testing with zero value, but if the motor seems weak when starting with normal load, the value can be increased step by step until there is power enough to start. Notice: Too high value is recognized from oscillation and/or twitching. If it is not possible to see the behavior of the motor and test the effect with momentary loading of a freely running motor the safest value for this parameter is zero.
- 12 Time out tripp will cut off the driving if continuous driving to the same direction exceeds the set value (statet in seconds).
- 13 This parameter is for resetting the start and hour counters. Saving value 1 will set to zero the drivers start and hour counters.
- 14 Parameter for choosing the forced run direction. F-run is started with long >5s command to RES/F-run terminal (pin 11)
- 15 Determines how the controller recovers from fault situation. Val 0. Recovers also with an opposite direction movement request. Val 1. fault requires a short (<5s) reset command to pin 11.
- 16 No function. Value of this parameter position has no effect.
- 17 Dead zone for determining the wanted positioning accuracy. If this window value is small the positioning is tended to be done more accurately. If value is too small the application is not capable to exceed this accuracy, and can not find or maintain the set position steadily. In this case the value should be increased.
- 18 Braking zone value is determined as a percentage of the full movement range. It determines how early driver starts to slow down before reaching the right position. Main rule is that small value for slow applications and high value for fast applications.
- 19 & 20 Start and stop ramps are used to smoothen the speed and direction changes. The parameter value is the time from 0-100% and from 100%-0 speed.
- 21 & 22 are for determining the control signal range limits. Value can be given as Volts, 0 to 550 (0 to 5,5V). The values can also be measured automatically by setting the parameters to value to 551. The card will then measure the range min. and range max. voltages on the POSITION SET input. Pls. read also the chapter "Control range setting".
- 23 & 24 Inner (BW) and outer (FW) SW-limits. With these adjustable limits the movement range can be limited to suite the application. Notice: the forced run will over drive these points.

EM-324-SPF POSITIONING DRIVER 12-24V 4A

FEATURES

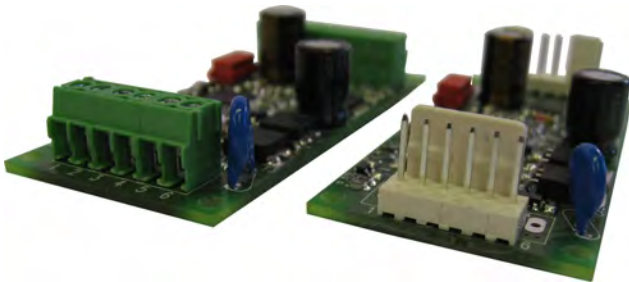

- quadrature pulse counting
- multiple dynamic settings
- solid state power stage
- one or two pulse feedback
- voltage or mA control
- position accuracy max. 0.2%
- versatile setting options
- digitally settable parameters
- housing options available
- 2/16kHz pwm frequency options
- CE marked product

EM-324-SPF is a positioning driver to be used with DC-motors. The solid state power stage operates with high efficiency and as is realized with FET-transistors. Its literally everlasting compared to relay solutions. Feedback is done with one or two line pulse signal. Although position feedback can be done with one pulse line it is always preferred and more secure to do it with two 0°/90° pulse lines. This driver includes an analog control with three signal ranges, 0-5,5V, 0-11V or 4-20mA. Input is freely scalable inside the range. The max. electrical accuracy of the driver and feedback is 0.2% which is adequate for most actuator positioning applications.

The settings and adjustments are done with parameters as in all new generation Electromen products. Included in the parameters is also the learn routine which will help to determine the full movement range fast and easily. Additively the movement range can be modified from both ends with SW-limit parameters. Possible cumulating pulse count errors can be avoided with manually or automatically triggerable home drive. Current limits and driving speeds can be set individually for both directions. Driver includes also many other dynamic adjustment features like parameter for load compensation, dead-zone setting (positioning window), start and stop ramps for smooth direction change and braking zone for well operating positioning.

The parameter setting and status monitoring is done with EM-236 Interface Unit. With EM-236 the right parameters can also be copied easily to other driver units. The on-board LED-light indicates the possible fault situations with blinking codes. If needed, the fault alarm can be also given out trough combiport (pin. 13). This port can be set as "position OK." output or it can work as an analog position signal output. Additively it can work also as disable input. Device is EMC tested for industrial and household environment and operating temperature range is quite wide. There are also same housing options available for EM-324-SPF driver card as for the standard EM-324.

TECHNICAL DATA

Supply voltage	10-35V
Shut down voltage	8V
Power up voltage	9V
Motor current cont.	4A at 2kHz / 3A at 16kHz mom. 6A (Ta<50 °C)
Current limit	0.1-6A (in start max. 8A)
Overtemp. limit	100°C
PWM frequency	2kHz / 16kHz
Pulse sampling rate	0.2ms
Input freq. of pulse lines max	800 Hz
Control input ranges (position)	0-5,5V / 0-11V / 4-20mA
Positioning potentiometer	10k recom. 22k max.
Input resistor for mA-signal	250ohm (socket on board)
Position out. signal range	0-5V or 0.5 - 4.5V, 0V for FAULT
Digital input levels	high=4-30V, low=0-1V
Digital input impedances	typ. 47kohm
Limit-FW / -BW and pulse inputs	imp. typ 10kohm
COMBIPORT pin.13	
- Fault output, NPN, open coll.	max 30V / 1A
- Disable input	Uin < 1V (NPN)
- position output impedance	1kohm
Connectors for motor and supply	max. 2.5mm² cable
Connectors for signals	max. 1mm² cable
Operating temp(Ta)	-40...60 °C
Dimensions	72x42x25mm
Weight	80g
CE-tested for household and industrial environment (EMC)	EN-55022B, EN-61000-4-3, -4, -5, -6 passed

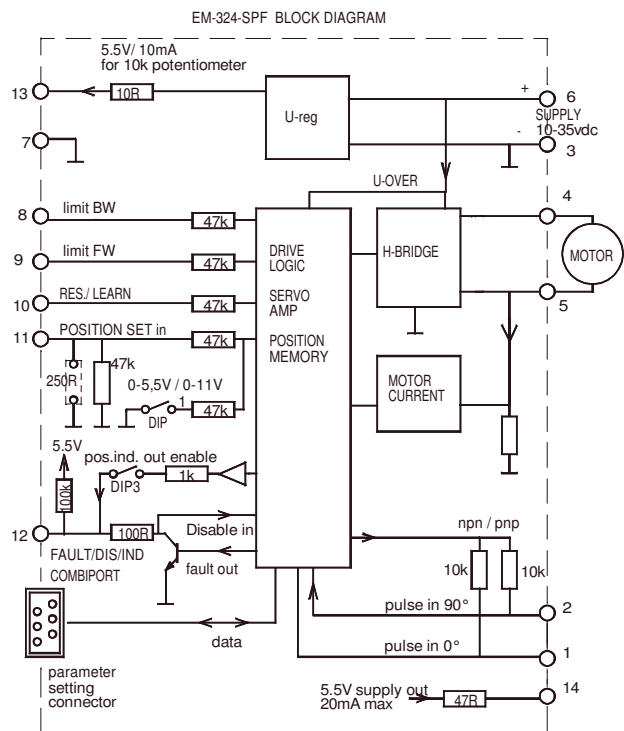

CONNECTION ADVICE

Supply voltage should be in the limits of 10-35Vdc.
Ripple should be lower than 30% even with max. load.
NOTICES !

1. Wrong supply polarity can cause damage the device.
2. There is no inbuilt fuse in this device. Use an external fuse which is chosen according to your application.
3. that function and scale of some of the input and output terminals is depending on the selected parameter values and defined ranges.
Please, see the parameter list and explanations.

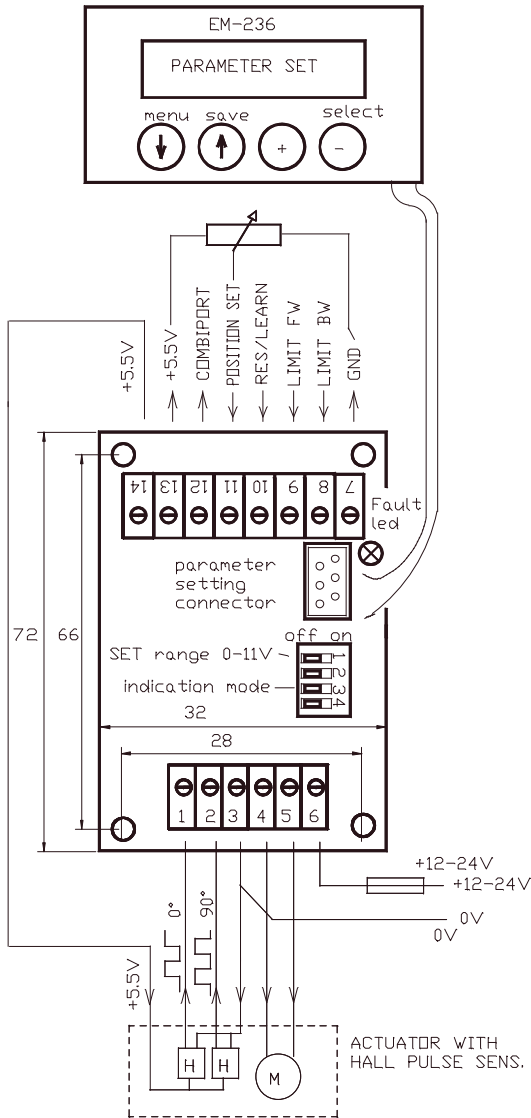

Pulse edges of 1 and 2 pulse lines

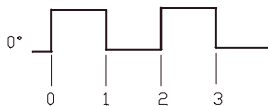

One pulse mode includes no direction information

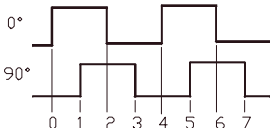

Two pulse, quadrature pulses offers also the direction information

TAKING IN TO USE

The setting of the controller is done with parameters, and the parameters can be set and edited with EM-236 Interface Unit. Making changes is easy and precise. Copying the parameters to multiple units is simple and accurate. The same parameters that are saved to one unit can be copied to another unit with one push of a button. After the two first parameters have been set according to the application, the actuator and control wires can be connected and operation can be adjusted with the remaining parameters.

Position feedback

Select 1 or 2 pulses lines with parameter 1 according to your application. The position information has more risk to be corrupted when controller is used with one pulse line, as the signal does not have information about the direction of the movement. For example in fast direction change with difficult loads few pulses are more easily counted to wrong direction. So it is recommended to use two pulse lines (0° and 90°) when ever available.

Full range

Full range is the full mechanical movement of the linear motor or positioning system. At first it is always needed to determine the full range before it is possible to drive the system. When the full range is determined it is also set to correspond the selected and set control range that can be for example 0-5V. Position feedback is received as pulses, and full range is determined as the number of pulse edges received during the full movement from start to end. If this number is known it can be set as the value of parameter 25 (Full range).

Home run

The position feedback is received as pulses so the driver can not know the right position before its pulse counter is reset in some known position. Home run command will drive the motor to selected end of the full range and there it will reset the pulse edge counter. Before the positioning can be used the home run must be done. After home run the position is saved to the drivers memory and will be valid even after the power is cut off and restored. Home run is configured with parameter 14, values 1 or 2.

Learn routine

Learning is a special option for finding the full range and taking the system in use with out knowing the number of pulses for full range. Learn routine is selected with par. 14 val. 7. and started with 5s command to RES/LEARN input. Learn routine will drive the motor forward (FW) until it reaches the outer end then it starts the motor backwards (BW) and drives to inner end. During this routine the driver "learns" the number of pulse edges for full range and also retrieves the absolute position by resetting the counter in the inner end. After learn routine is done the driver can be used for positioning and par 14 should be set to some suitable value for normal use of the application. Notice: Learn routine is ran to the hard end (or to the limit switches if wired). Notice: To see the learned and right number of the full range pulse edges, you have to down load (OK to Load&Edit) the parameters from driver with EM-236 Interface Unit once again. Or if you are viewing the par. 25 while learn routine you can try to change the value and the EM-236 Interface unit will first display the learned range. After this its possible to edit this reading.

Auto home

Auto home is an automated home run that is triggered during normal operation when ever the motor is run to the FW or BW end switch or close to the software end limit (SW-limit). Well configured auto home can effectively prevent cumulating position error. Its specially useful when working with only one feedback pulse line. Auto home configures with par. 14 (values 3,4,5 or 6). Notice. The auto-home will be ran to the hard end (or to the limit switches if wired). If you choose the auto-home triggered from limit switch inputs or SW-limits, the option of using the 5seconds command to RES/LEARN input is also available.

Control range setting

Options for max. ranges are 0 to 5,5V, and 4 to 20mA if you place a 250ohm resistor to the resistor socket on the driver board. Using 0 to 11V range requires you to set the DIP switch 1 to "ON" position. Your individual control scale you can either set with parameters 21 and 22 as Volts or you can let the driver to measure your min. and max. control values. If you choose to set the min. and max. as Volts, pls. notice that the values are in ratio to the lowest range 0-5,50V, and with 0-11V range you have to divide the actual voltage with two. With current signal the right value is $l \times 250$. Eg: 4-20mA = 1,0 - 5,0V.

Most accurate way is to let the driver to measure the values. So first connect and adjust minimum value to set input (pin.12) and change the par.21 to val. 551, after value stops blinking the display shows the measured value. Then adjust the maximum control value to pin.12, and change par.22 to 551. After a while you will see the measured value in display. Always remember to to save with long push to save button, before disconnecting EM-236 and taking power off from the driver. Notice: If control min. value is set higher than max. value the movement range will be inverted and set accordingly.

Positioning dynamics (continued on the next page)

Dead zone (par. 17) is to determine the accuracy of positioning.

This parameter has the major effect to positioning accuracy. The smaller it is determined the more accurately the positioning is done. Notice. If it is set too small compared to accuracy level of the mechanics an oscillation or unstability in positioning will occur.

Braking zone (par. 18) is used to optimize the time needed for positioning. Too high value slows down too early, and too low value will cause an fast position passing and needs a corrective return driving.

Start and stop ramp (par. 19 & 20) are to smoothen the direction change. Often suitable value for stop ramp is half of start ramp. Too long stop ramp can make the direction change too time consuming and too short can cause mechanical stress and non desired aggressivity.

Load compensation (par.11) when set to right value, will ensure the needed force to start driving and to taking the load in to the right position. With high load and too low load compensation value, the motor dont have force enough to reach the right position. Start testing with zero value and increase value untill motor behaves unstable and twitching. Thumb rule in this point is to decrease the value with 25%.

Current limits should be set according to the motor nominal max. current or according to the required current of the application (if lower than nom).

Indications

Fault situations are indicated with coded blinking of the red LED. Fault alarm can be forwarded out trough combiport (pin.13). Fault situation is reset with a short (<5s) command to RES/LEARN input (pin.11). Some faults are reset automatically with a new position command to opposite direction. Instead of fault indication the combiport can be set to indicate the status of the positioning as an "on position" output, or it can be set to give an analog position information with 0-5V or 0.5-4.5V signal. Configuration of the combiport is done with par.9. Notice: If it is set to give analog information out (par.9 val3/4), also the DIP-switch 3 should be set to ON position. If Combiport (pin 13) is selected to be fault output, it will also work as disable input when externally pulled down. If this terminal is selected to be used for indication the "disable in" function can be set and transferred to work trough limit input terminal pin 9 or pin 10 (par.15).

Adjustment and settings

Parameter setting is done with EM-236 Interface Unit, which is connected to a powered driver unit to the red connector. During the start up routine the Interface Unit will display information about itself and then the name and program version of the target device. Then it will stay on displaying EDIT & LOAD. Pushing the "yes" button will up load and show the parameter list of the controller. Now the user can scroll the parameters with arrows, and make value changes with + and - buttons. Edited value is effective after few seconds when the value stops blinking. But notice, that the change will not be saved untill you give a long push (>2s) to the "save" button. This will save the values to the EM-236s memory also. Now it is easy to copy the same values to another driver. Just connect the unit to a powered driver and after the start up routine just press a long "save". You can repeat this untill all needed units have been configured.

LIST OF PARAMETERS prog. v1.3 (defaults in parentheses)

- 1 Feed-back mode : one-pulse=1, dual-pulse=2 (1)
- 2 Limit and pulse input logic (1)
 - 1= limit inputs PNP / pulse inputs PNP
 - 2= limit inputs PNP / pulse inputs NPN
 - 3= limit inputs PNP inverted / pulse inputs PNP
 - 4= limit inputs PNP inverted / pulse inputs NPN
- 3 Speed FW: 20-100% / 0-100 (100)
- 4 Speed BW: 20-100% / 0-100 (100)
- 5 Speed HOME/LEARN: 20-100% / 20-100 (60)
- 6 Current limit out, FW: 0.1-6A / 1-60 (30)
- 7 Current limit in, BW: 0.1-6A / 1-60 (30)
- 8 Current trip delay: 0-255ms / 0-255 (100)
(0 = tripp not in use)
- 9 Combiport (pin 13) function: 1-4 (1)
 - 1= used as Fault out / Disable in (fault/dis=0V)
 - 2= gives the "on position" data (on pos=0V)
 - 3= gives position info out with 0-5V
 - 4= gives position info with 0.5-4.5V and fault =0V
- 10 Over voltage limit: 15-40V / 15-40 (35)
- 11 Load compensation: 0-255 / 0-255 (0)
- 12 Time out: 1-255s. / 1-255 (0= not in use) (0)
- 13 Hour and start counter reset (0)
set value = 1 and press SAVE -> hour and start counter reset
- 14 Home run / learn function: 1-7 (1)
 - 1= Home run with RES / LEARN input to BW direction (>5s. comm.)
 - 2= Home run with RES / LEARN input to FW direction (>5s. comm.)
 - 3= Auto-Home from BW LIMIT input to BW direction (pin 9)
 - 4= Auto-Home from FW LIMIT input to FW direction (pin 10)
 - 5= Auto-Home triggered with inner soft limit to BW direction
 - 6= Auto-Home triggered with outer soft limit to FW direction
 - 7= Learn routine with >5s command to RES /LEARN input (pin.11)
- 15 Disable input configuration (0)
0= Disable only to pin.13, 1=disable to pin.10, 2=disable to pin.9
- 16 Not in use
- 17 Dead zone : 0,2-5% / 2-50 (10)
- 18 Braking zone : 1-8% / 1-8 (3)
- 19 Start ramp : 0.1-2.5s / 0-25 (10)
- 20 Stop ramp : 0.1-2.5s / 0-25 (3)
- 21 Set value min: 0...5.50V / 0-551 (0)
- 22 Set value max: 0...5.50V / 0-551 (550)
For parameters 21 and 22 value 551 will do an auto setting
- 23 Inner (BW) SW-limit: 0...+50% / 0-500 (5)
- 24 Outer (FW) SW-limit: 0...-50% / 0-500 (5)
- 25 Full range (pulse edges) 100-65535 / 100-65535 (1000)
- 26 PWM frequency 1 = 2kHz, 2=16kHz (1)

FAULT LED -blinking codes

- | | |
|---------------------|---------|
| 1. I-trip | 1 blink |
| 2. pulse lost | 2 blink |
| 3. over temperature | 3 blink |
| 4. over voltage | 4 blink |
| 5. time out trip | 5 blink |
| 6. learn corrupted | 6 blink |

MONITORABLE VALUES (Can be read with EM-236)

- 1 fault code (see above) 1-6
- 2 motor current 0-20A / 0-200
- 3 target position 0-100,0% (0-1000)
- 4 realized position 0-100,0% (0-1000)
- 5 position as pulse edges 0-65535
- 6 hour counter (max.65535h)
- 7 start counter (max.65535)
- 8 start counters over flow counter (max. 65535)

ABOUT PARAMETERS

1. Feedback mode is a mandatory setting to be done according to the application. 1= for one pulse line only, 2= two pulse lines for 0° and 90° pulses.
2. Limit and pulse inputs (pins 9, 10, 2 and 3) can be set to work with positive or negative logic. Signal can be either pulling up =PNP or down to 0V which is often marked as NPN signal.
- 3 & 4 driving speed to FW (out) and BW (in) directions.
- 5 The speed setting for "home run" and "learn" routines.
- 6 & 7 Current limit setting for FW (out) and BW (in) driving directions.
- 8 Current tripp delay time 1-255ms, if set to 0 the tripp is disabled
- 9 Combiport configuration (pin 13). This terminal can work as combined input-output. It can be fault output and disable input or an on position indicator giving an "on position" signal after a succesfull positioning. It can also be used to indicate the position with continuous voltage signal 0-5V (val.3) or 0.5-4.5V + 0V fault (val.4).
Notice: With val. 3 or 4, also the DIP3 must be set to "ON" position.
- 10 Over voltage limit. Motor is switched to free wheel if the selected voltage level is exceed. This saves the driver or other devices in supply line from over voltages in case the motor generates surplus energy during slow down or braking.
This can happen eg. in vehicle or lifting applications.
- 11 Load compensation (Rxl-comp) ensures good torque with low speeds. It is good to start testing with zero value, but if the motor seems weak when starting or slowing down to the right position this value can be increased carefully and step by step.
Notice: Too high value is recognized from oscillation and/or twitching.
- 12 Time out tripp will cut off the driving if continuous driving to the same direction exceeds the set value (statet in seconds).
- 13 Usage counter reset parameter is for manual reset of counters. Choosing and saving value 1 will reset the hour and start counters.
- 14 Home run direction and start condition setting or enabling the learn routine for finding the full movement range.
Home run can allways be started with RES/LEARN input (pin 11). Auto home can be started with actual limit switch inputs or with so called SW-limits (par. 23 and 24). Last special option (value 7) is for starting the learn routine. That is an end to end drive routine to count and determine the real full movement range.
- 15 In case the pin.13 is used for indication, the limit switch inputs pin 9 or 10 can be configured to work as disable input.
- 16 Not in use in this program version.
- 17 Dead zone is for determining the suitable positioning accuracy. If this positioning window value is small the positioning is tended to be done more accurately. If value is too small compared to the accuracy of the other parts of the application, the system might not be able to work properly. Notice. Other parameters like braking zone and FW/BW speed settings will also affect to the positioning behaviour.
- 18 Braking zone value is determined as a percentage of the full movement range. It determines how early driver starts to slow down before reaching the right position. Main rule is that small value for slow applications and high value for fast applications.
- 19 & 20 Start and stop ramps are used to smoothen the speed and direction changes. Its the time from 0-100% or from 100%-0 speed.
- 21 & 22 are for determining the control signal range limits. Value can be given as Volts, 0 to 550 (0 to 5,5V), or the min. and max. values can be measured automatically by setting value to 551.
Then the card will measure the signal in the POSITION SET input. Pls. read also the chapter "Control range setting".
- 23 & 24 Inner (BW) and outer (FW) SW-limits. With these adjustable limits the movement range can be limited to suite the application.
Notice: if either of these SW-limits is used for auto-home (par.14) the motor will drive over the limit when executing the home run.
- 25 The full-range is determined by setting the known or calculated full range pulse edge count to be the parameter value. Alternatively the value can be defined by making the learn run (par.14 val.7)
Notice. The learned pulse edge number is up dated to the EM-236 Interface unit display when you make a new Load & Edit data query or try to change the value right after learn routine.
to change
- 26 PWM frequency selection 2khz offer more current and 16kHz gives quiet run.

EM-165 POSITIONING DRIVER 12-32Vdc

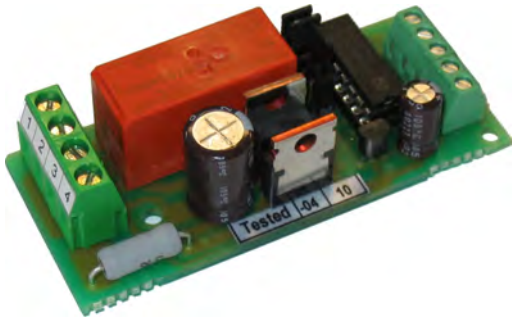

FEATURES

- small in size
- low cost
- pos. accuracy. typ. $\pm 1\%$
- good efficiency $>92\%$
- for motors 5-200W
- start- and stop-ramp
- overload protected
- selectable current limit
- rail base mountable

EM-165 is a low cost positioning driver. It has an inbuilt servo amplifier and a power stage for controlling a dc-motor. It is suitable for driving a spindle motor equipped with feedback potentiometer. EM-165 is best suited for slow and medium speed systems with a transitional period of 2...30s (from end to end). The current limit is settable and can be used to limit the torque of the motor. Current trip feature will shut down the driver in fault situation, if either current is on the limit for over 2s, or if it takes more than 30s to reach the set value. In fault situation the error output will be activated. Reactivation from the trip situation is done by applying a reverse control command.

Positioning is done by giving a new set value using the set value potentiometer or voltage signal 0-5V. The driver compares the feedback value to the set value and starts to drive the motor towards the set value. When these values begin to approach each other, the driver will slow down, and when the values are identical the motor stops. EM-165 is small sized and easy to install. It is possible to use screw fastening or install the driver in to a rail with a rail mounting base which is available as an accessory. The power stage is equipped with self recovery overload and over current protection, but the use of an external fuse is recommended.

TECHNICAL DATA

Operating voltage	12-32Vdc
Idle current	$< 40\text{mA}$
Protections	overheat (self recovery), short circuit approx. 30A
Load capacity	5A continuous 8A 15s "on", 15s "off" 12A 5s "on", 15s "off"
Current limit	2, 4, 7, ja 12A settable
Accuracy	typ. $\pm 1\%$ of range
Input ranges	0-5V (pin 7 & 8)
Input impedance	$>1\text{Mohm}$
Pot.recommendation	1...100kohm.
Ref. voltage pin-5	5V (max. 15mA)
Error out	NPN -open coll. 30V / 50mA
Efficiency	$> 92\%$
Operating temp.	$-20...60^\circ\text{C}$
Dimensions	72.5x31.0x24.0mm
Weight	approx. 40g

BLOCK DIAGRAM EM-165

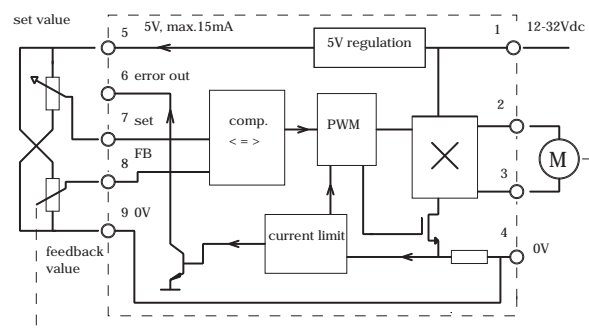

OPERATING INSTRUCTIONS EM-165

IMPORTANT !

Supply voltage must be filtered 12-32 VDC with less than 20% ripple.

Choose the fuse according to the application (max. 15A).
Check the polarity before connecting.

SETTINGS

CURRENT TRIP (DRIVE SHUT DOWN)

The current trip function is activated with jumper named "I-trip". If current trip is activated the driver will be shut down and the error output will appear in the following cases:

- overcurrent situation for over 2s
- positioning takes longer than 30s.

If the current trip is not activated, the driver will not be shut down, but the error output will operate in the same manner as in activated mode.

CURRENT LIMIT (MOTOR TORQUE LIMIT)

There are four settable current limit values. Attached the map of the values and settings.

TAKING ON DUTY

Connect the wiring and make sure, that the current limit is set according to the application (not too high!). Switch the power on. The system should now find right position and follow the adjustment of the set value potentiometer.

If system only moves from end to end, or jam to the other end. Try to switch the motor wires (pin 2 & 3). Check also all other wiring.

If system is working o.k. but working direction is wrong. Switch both, motor wires (pin 2 & 3) and the feedback potentiometer wires (pin 5 & 9) at the same time.

If is needed to adjust the system range, it is possible to add serial trims or resistors to the potentiometer wiring.

APPLICATION 1

Driver working with spindle motor equipped with potentiometer. Adjust trims can be added for range trimming, if needed.

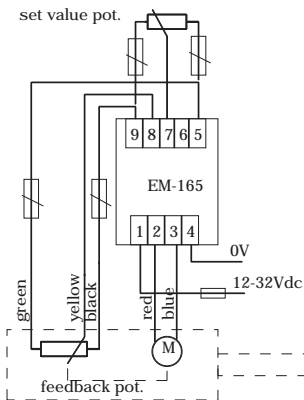

Spindle motor equipped with potentiometer, LINAK LA12

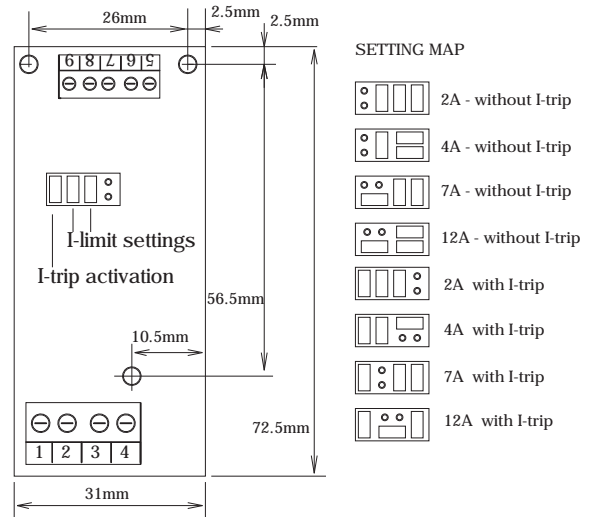

CONNECTION TERMINALS

1. Supply 12-32Vdc
2. Motor
3. Motor
4. Supply 0V, gnd
5. 5V-out, excitation for pots. max. 15mA
6. error-out NPN OPEN-COLL. max. 50mA
7. Set value input, 0-5V or potentiometer
8. Feedback input 0-5V or potentiometer
9. 0V, signal gnd

APPLICATION 2

Device drives angularly adjustable table. Feedback is coming from 0-5V inclinometer. Set value is 0-5V voltage signal.

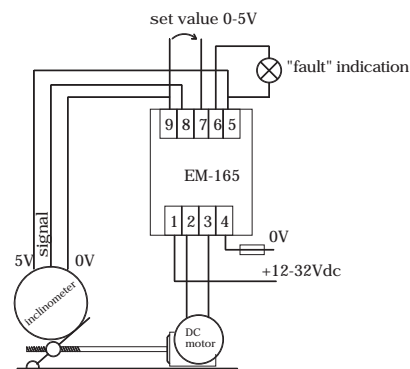

Inclinometer Bosch 0280 122 201 + gearmotor

EM-165pf POSITIONING DRIVER 12-32Vdc

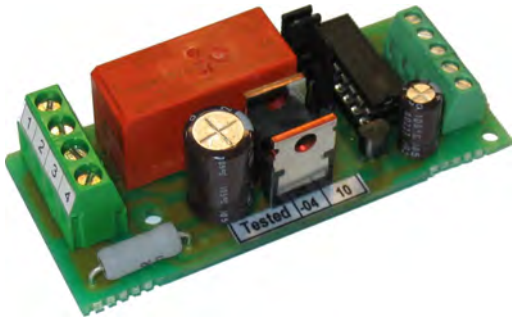

FEATURES

- Pos. accuracy typ. $\pm 1\%$
- High efficiency $> 92\%$
- For motors 5-200W
- Start- and stop-ramp
- Overload protection
- Error indication
- Control value with pot. or voltage
- 128, 256, 512, 1024 pulse ranges
- Adjustable current limit
- Rail base mountable
- EMC-tested (CE)

EM-165pf is a positioning driver for pulse feedback systems. Potentiometer or direct voltage signal can be used as control value. The device has inbuilt up-down counter and servo amplifier for positioning. There are four counter ranges: 128, 256, 512 and 1024 pulses. Additionally the range can be fine-tuned. The power stage of the unit is capable of directly driving a DC-motor. EM-165pf is suitable for example driving a spindle motor equipped with pulse transducer. EM-165pf is best suited for slow and medium speed systems with transitional period of 4...50s (from end to end). The current limit is settable and can be used to limit the torque of the motor. Current trip feature will shut down the driver in fault situation, if either current is on the limit for over 2s, or if it takes more than 50s to reach the set value. In fault situation the error output will be activated. Reactivation from the trip situation is done by applying a reverse control command or by switching power off and back on.

Every time the unit is switched on, it will first drive the mechanism to one end and reset the counter. After this it will drive the mechanism to control value. Every time the unit receives new control value, it starts the motor and begins to compare the counter value with control value. When these two start to approach each other, the controller slows down and finally stops when the values are identical. Besides using one of the pulse ranges, the positioning range can be fine tuned with control value range trim. EM-165pf is small in size and can be mounted into a rail using a rail mounting base or screws. The unit has a self recovery overload protection and short circuit protection. However the use of an external fuse is recommended.

TECHNICAL DATA

Supply	12-32Vdc
Idle current	$< 40\text{mA}$
Protection	self recovery thermal prot. short circuit prot. approx. 30A
Load capacity	5A continuous 8A 50% use max. 30s 12A 20% use max. 10s
Current limit	0- 12A settable
Precision	typ. $\pm 1\%$ range
Control value range	0-5V or 0-10V (pin 7)
Input impedance	100kohm
Potentiometer	1... 10kohm.
Pulse in	4-30V 4.7kohm
Pulse width	$> 5\text{ms}$
Pulse frequency	max 200Hz
Pulse range	128, 256, 512 or 1024
Auxillary pin 5	5V max. 15mA
Error output	NPN -open coll. max. 30V / 50mA
Efficiency	$> 92\%$
Oper. temperature	$-20...60^\circ\text{C}$
Dimensions	73,32,20mm
Weight	approx. 40g

BLOCK DIAGRAM EM-165pf

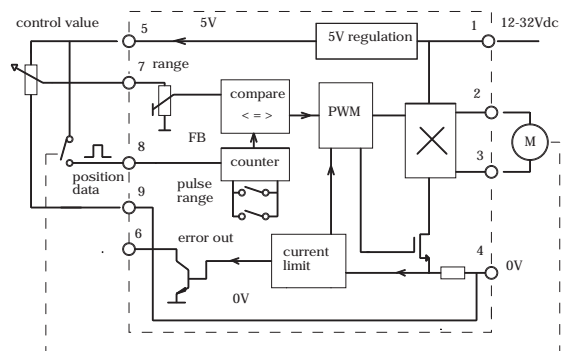

OPERATING INSTRUCTIONS EM-165pf

IMPORTANT !

Supply voltage must be filtered 12-32 VDC with less than 20% ripple. Choose the fuse according to the application (max. 15A). Check the polarity before connecting.

SETTINGS

CURRENT TRIP (DRIVE SHUT DOWN)

When current trip activates, the driver will shut down and the error output will activate. Current trip will activate in either of the following cases:

- overcurrent situation for over 2s
- positioning takes longer than 50s

CURRENT LIMIT (MOTOR TORQUE LIMIT)

Maximum motor current can be limited with current limit trim.

PULSE RANGE

Minimum value is from one end to other end. Setting is done with two jumpers.

RANGE

Control value scale trim, use this to fine tune range.

OPERATING INSTRUCTIONS

Connect the application and make sure the current limit is not set too high. Choose the pulse range according to the application.

When power is switched on, the unit will perform a reset operation, in which positioning count value is set at zero in certain position. In practice the unit drives motor towards the other end until no more pulses are received, in other words system is driven home after which counter is reset. After this process control value is used to drive system to the desired position. Pulse receiving can be ended by using an external limit switch.

Functional direction can be changed by exchanging the motor wiring polarity.

EXAMPLE 1

In this example positioning data is derived from internal pulse switch in spindle motor. Potentiometer is used to set control value. Spindle motor has internal limit switches, which will take care of reset operation.

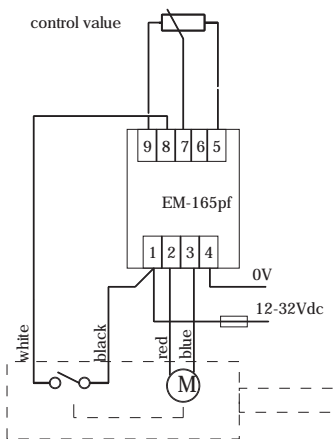

Spindle motor LINAK LA.12 with pulse output.

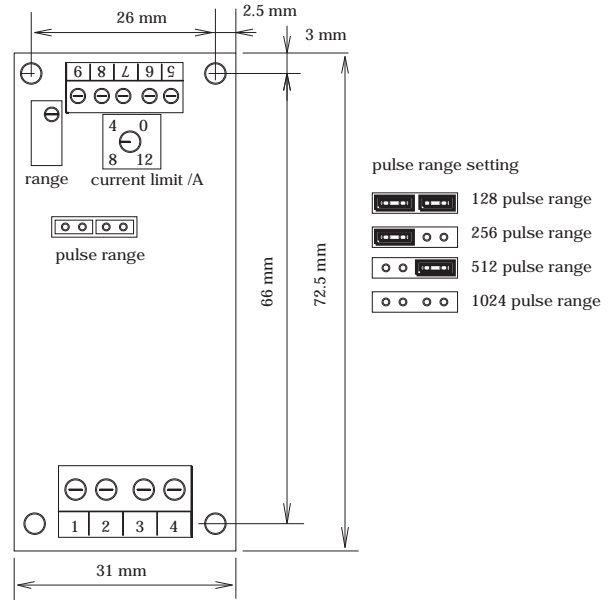

pulse range setting

- 128 pulse range
- 256 pulse range
- 512 pulse range
- 1024 pulse range

TERMINALS

- 12-32Vdc
- Motor
- Motor
- 0V, gnd.
- 5V ref. output max 15mA
- Error output OPEN-COLL. 50mA
- Control value input 50mV-5V, 100mV-10V or pot.
- Positioning data input (4-30V pulse).
- 0V, signal gnd

EXAMPLE 2

Application feedback is derived from pulse sensor. Control value is set with 0-5V or 0-10V voltage signal. "Home"-switch will take care of reset operation, the diode above switch makes it possible to startup in other direction, when positioning starts.

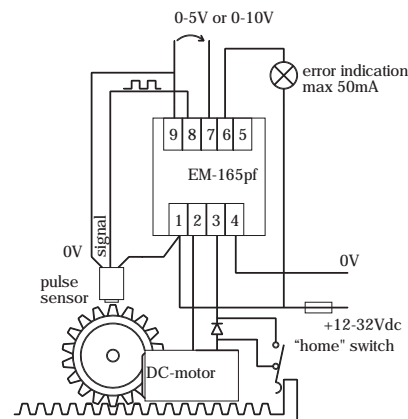

Pulse sensor + gear motor

EM-143s DC-MOTOR SERVOCONTROLLER 12-32V 4A 4-QUAD

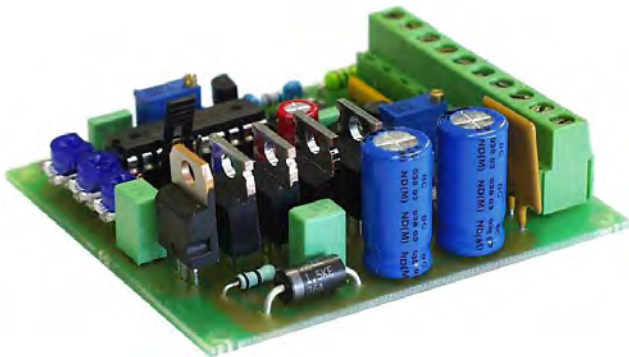

FEATURES:

- Small size
- Positioning precision 1/400
- Four drive quadrants
- High efficiency >92%
- For motors 5-100W
- Rail mounting base fittable
- Adjustable current limit
- Adjustable output current
- Adjustable positioning window
- Settable maximum speed

EM-143s is a motor controller for permanent magnet DC-motors. The unit is primarily designed for positioning usage, where position information is derived from potentiometer or as voltage, for example spindlemotors equipped with potentiometers.

The unit is so called four quadrant controller, in other words it drives and brakes in both directions. The braking is regenerative by nature as it feeds braking energy back to power source. If the power source is not a battery the unit will feed braking energy to motors internal resistance.

EM-143s has a window comparator, which measures the difference between feedback and reference value and uses this to control the motor. The unit has an adjustable positioning window, that specifies the level of difference to occur for correction to take place, in other words the precision of positioning. Range and zero -trims can be used to match the reference value with feedback value. Using the start level adjustment the minimum motor voltage can be suited for the application. Too low start level will result in motor warming and increased current consumption as a consequence of the motor not being able to perform small corrections due to lack of power. Too high start level will cause too rapid corrections or oscillation.

Motor current can be limited using motor current adjustment. It is possible to switch current limit into so called trip mode in which current limitation will switch off drive. If the current limit has been exceeded for one second, the unit won't be active until driven into opposite direction.

The power stage is protected against voltage peaks, overload and momentary shortcut. Reversed polarity connection should be avoided even though the unit is equipped with self recovery fuse.

TECHNICAL DATA

Supply voltage	12-32Vdc
Idle current	< 30mA
Fuse	4A self recovery
Load capacity	4A continuous 8A mom. (8s/30s) 14A mom. (2s/30s)
Current limit	1-14A
Operating freq.	approx. 22kHz
Control voltage	0-5...0-10V
Control potentiometer	1kohm...10kohm
"stop" control	4-30V "stop" <1V or open "drive"
Trip-indication output	NPN -open coll. 30V / 100mA
Input imp.	pins 6 and 9 = 50kohm pin 8 = 35kohm
Efficiency	>92%
Operating temp.	-10...50°C
Dimensions	(72 x 65 x 25) mm
Weight	approx. 80g

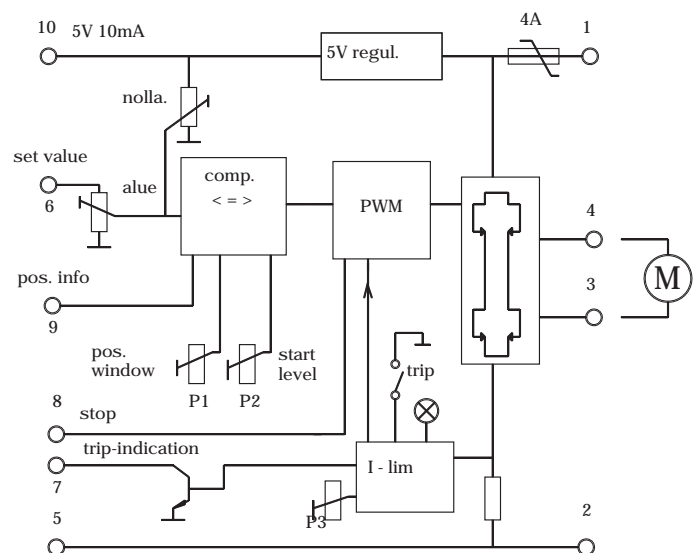

EM-143s USAGE

IMPORTANT !!

Supply voltage filtered (<20% ripple)
12-32VDC.

!! Check the polarity before connecting.

ADJUSTMENTS

Recommended start values in brackets.

START LEVEL (25%)

Adjustment sets motor start level.

Start level should be set so that motor always starts reliably but not too rapidly.

CURRENT LIMIT (= motor nominal current)

Set max. motor current (moment).

A red led indicates the activity of current limit.
At first it's recommended to set current limit low and increase the current to suitable level when the application seems to work.

POSITIONING WINDOW (2%)

Sets so called positioning window dimension.
Suitable value depends on the mechanics of the application. First set to the maximum, then decrease until application starts twitching, then set backwards until twitching ends. START LEVEL and WINDOW adjustment affect each other a little. To obtain best possible precision and positioning window start level must be precisely convenient.

RANGE AND ZERO

Use these adjustments to match reference and feedback values. For example, when using 100mm spindlemotor with only 70mm needed. Range adjustment is used to set frequency and zero for position, for example center. NOTICE that range adjustment also affects zero. Zero doesn't affect range. If these adjustments are inadequate external series resistors can be added to feedback potentiometer.

RANGE RESISTANCE (2.2k) (maximum speed)

Resistors are used to optimize the operation in specific voltage range.

- 1.8k 28V application
- 2.2k 24V application
- 3.3k 18V application
- 4.7k 12V application

EXAMPLE 1

Basic application where both set value and position value is derived from potentiometer.

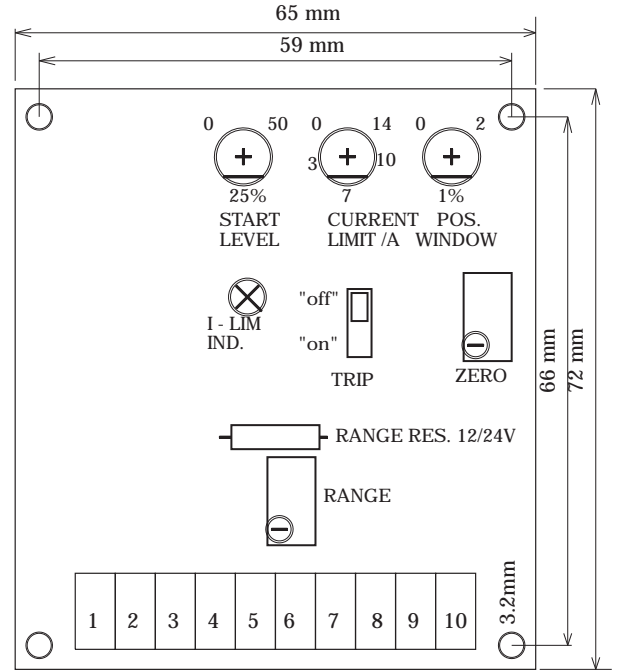
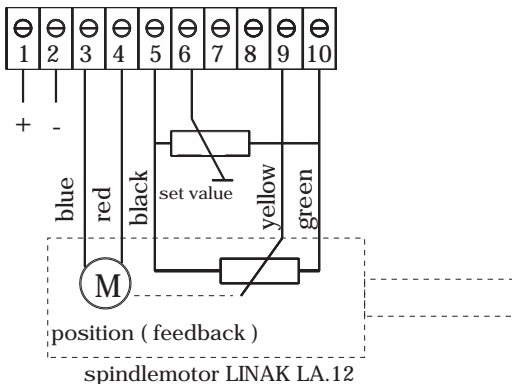

TERMINALS

- | | |
|--------------------------|---------------------------|
| 1. Supply voltage 12-32V | 5. Signal gnd (0V) |
| 2. Supply voltage 0V | 6. Set value in |
| 3. Motor out - | 7. Trip indication 100mA |
| 4. Motor out + | 8. Stop |
| | 9. Position feedback in |
| | 10. 5V 10mA reference out |

INTRODUCTION

Connect the application, adjust set value to approximate center. Switch on, application should seek its way to a certain point. Change the set value and position should change accordingly, if the application runs from one end to the other exchange motor leads with each other (3 and 4). Adjust the precision and dynamic to suit your application as described before.

EXAMPLE 2

In this application set value is given in voltage, and position from potentiometer.

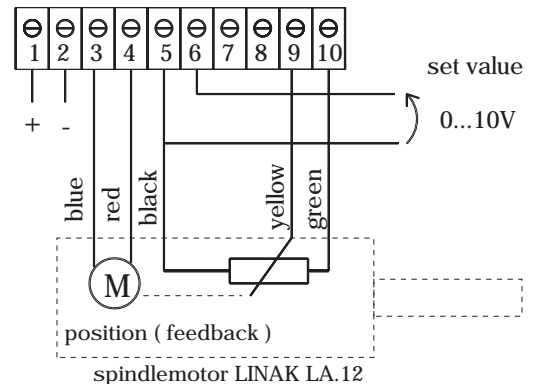

EM-167 COMPACT POSITIONING DRIVER

12-32Vdc



FEATURES

- small size
- pos. accuracy typ. $\pm 1\%$
- good efficiency $> 92\%$
- for motors 5-200W
- start- and stop-ramp
- overload protected
- adjustable current limit
- adjustable range

EM-167 is a compact positioning driver. The unit is equipped with its own set value potentiometer. EM-167 also has an inbuilt servo-amp. and power stage which is capable of driving a DC motor directly. It is suitable for driving a DC spindle motors equipped with feedback potentiometer. EM-167 is best suited for slow and medium speed systems with a transitional period of 2...30s (from end to end). The current limit is adjustable and can be used to limit the torque of the motor. Current trip feature will shut down the driver in fault situation, if either current is on the limit for over 2s, or if it takes more than 30s to reach the set value. In fault situation the error output will be activated. Reactivation from the trip situation is done by applying a reverse control command.

Positioning is done by giving a set value using the EM-167 internal potentiometer. The driver compares the feedback value to the set value and starts to drive the motor towards the set value. When these values begin to approach each other the driver will slow down, and when the values are identical the motor stops. The operating range can be adjusted / limited from both ends with min. and max. adjustments. EM-167 is small-sized and easy to install. Due to its wide temperature range, the unit is suitable also for vehicle use. The power stage is equipped with self recovery overload and over current protection, but the use of an external fuse is recommended.

TECHNICAL DATA

Operating voltage	12-32Vdc
Idle current	< 40mA
Protections	overheat (self recovery) short circuit approx. 30A
Load capacity	4A continuous 8A 10s "on" 20s "off" 15A 3s "on" 30s "off"
Current limit	0-15A adjustable
Range adj.	0-30% low. & 70-100% up.
Accuracy	typ. $\pm 1\%$ of range
Feedback input	potentiometer 1...100kohm or voltage signal 0-5V
Ref. voltage pin-2	5V max. 15mA
Error out	NPN -open coll. 30V / 50mA
Efficiency	> 92%
Operating temp.	-20...60°C
Dimensions	39x39x50mm
Weight	approx. 85g

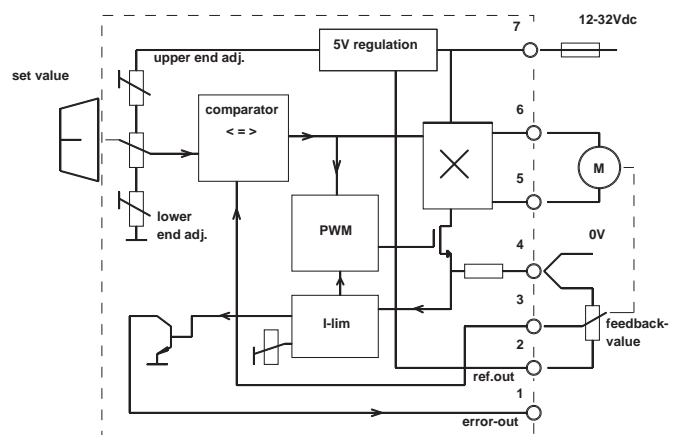

OPERATING INSTRUCTIONS EM-167

IMPORTANT !

Supply voltage must be filtered 12-32 VDC with less than 20% ripple.

Choose the fuse according to the application (max 15A).

Check the polarity before connecting.

ADJUSTMENTS

CURRENT LIMIT (MOTOR TORQUE)

First adjust the current limit equal to the rated motor current. After you get the application up and running, you can adjust the current limit to more suitable value for your application. In other words, use this adjustment to protect your motor and mechanics.

LOWER AND UPPER LIMITS (RANGE ADJUSTMENTS)

With these adjustments the range can be adjusted from both ends. Upper end from 70...100% of range and lower end from 0...30% of range.

For example, if the spindle motor range of movement is at maximum 0...100mm, using these adjustments the range can be reduced to 30...70mm at minimum.

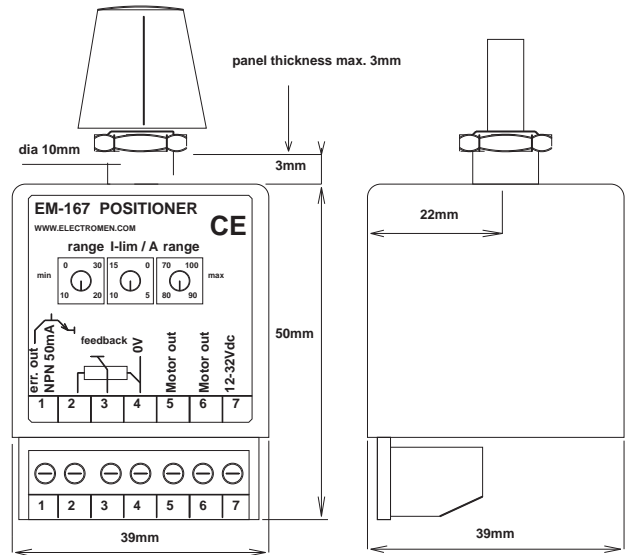

TAKING ON DUTY

Connect the wiring and make sure that the current is adjusted according to the application (not too high!). Switch the power on. The system should now find the right position and follow the adjustment of the set value potentiometer.

If system only moves from end to end, or jam to the other end. Try to switch the motor wires (pin 5 & 6). Check also all other wiring.

If system is working o.k. but working direction is wrong, switch both, motor wires (pin 5 & 6) and the feedback potentiometer wires (pin 2 & 4) at the same time.

CONNECTION TERMINALS

1. error output, 30V / 50mA
2. 5V out, exitation for pot. max 15mA
3. feedback input
4. 0V, gnd
5. Motor
6. Motor
7. Supply 12-32Vdc

APPLICATION 1

Device connected to a spindle motor, feedback coming from spindle motor potentiometer.

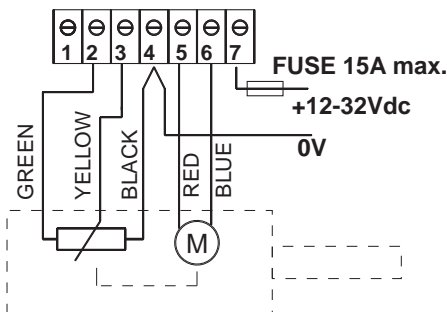

spindlemotor with feedback potentiometer LINAK LA.12

APPLICATION 2

EM-167 drives the angle of a table, the feedback is coming from 0-5V inclinometer.

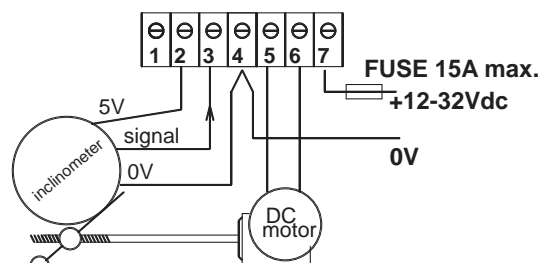

inclinometer Bosch 0280 122 201 + gearmotor

EM-241-SAF POSITIONING DRIVER 12-24V 15A



FEATURES

- analog feedback
- voltage or mA control
- position accuracy max. 0,2%
- solid state power stage
- small size, great performance
- digitally settable parameters
- versatile dynamic settings
- housing options available
- CE marked

EM-241-SAF is a positioning driver to be used with DC-motors. The solid state power stage operates with high efficiency as it is realized with FET-transistors. Its literally everlasting compared to relay solutions. Control and feedback is done with analog signal. Control signal can be a voltage in range of 0 to 11V or current from 0 to 20mA. Feedback signal can be in the range from 0 to 11V. Driver supports also a potentiometer feedback, with auxiliary voltage outputs of 0V and 5,5V to excitate the potentiometer. The max. accuracy available for positioningof is 0,2% that is adequate for most actuator positioning applications.

The settings and adjustments are done with parameters as in all new generation Electromen products. Movement range can be modified from both ends with SW-limit parameters. Current limits and driving speeds can be set individually for both directions. Driver includes also many other dynamic adjustment possibilities like parameters for load compensation, dead-zone setting (positioning window), start and stop ramps for a smooth direction change and braking zone for well operating positioning.

The parameter setting and status monitoring is done with EM-236 Interface Unit. With EM-236 the right parameters can also be easily copied to other driver units. The on-board LED-light indicates the possible fault situations with blinking codes. If needed, the fault can be forwarded trough combiport to other driver cards. Alternatively this port can be set to give out the "position OK" information or it can even indicate the position with an analog voltage signal. Device is EMC tested for industrial and household environment and operating temperature range is quite wide.

There are also some housing options available for EM-241-SAF driver card.

TECHNICAL DATA

Supply voltage	10-35V
Shut down voltage	8V
Power up voltage	9V
Motor current cont.	15A, mom. 30A (Ta<50°C)
Current limit	0.1-20A (in start max. 30A)
Overtemp. limit	100°C
Start and stop ramp	0-5s
PWM frequency	2kHz
Analog feed-back ranges	0-5V / 0-10V
Control input ranges (position)	0-5,5V / 0-11V / 0-20mA
input impedance for mA-signal	250ohm (resistor not incl.)
Position out. signal range	0.5 - 4,5V / 0-5V
Digital input levels	high =4-30V, low=0-1V
Digital input impedances	typ. 47kohm
Limit-FW / -BW input imp.	10kohm
COMBIPORT pin 13	
fault -output NPN, open coll.	max 30V / 1A
fault -input	Uin < 1V (NPN)
indication out impedance	1kohm
Connectors for motor and supply	max. 2.5mm ² cable
Connectors for signals	max. 1mm ² cable
Operating temp(Ta)	-40...60°C
Measures	72x42x25mm
Weight	80g
CE-tested for industrial environment (EMC)	
EN-55022B, EN-61000-4-3, -4, -5, -6 passed	

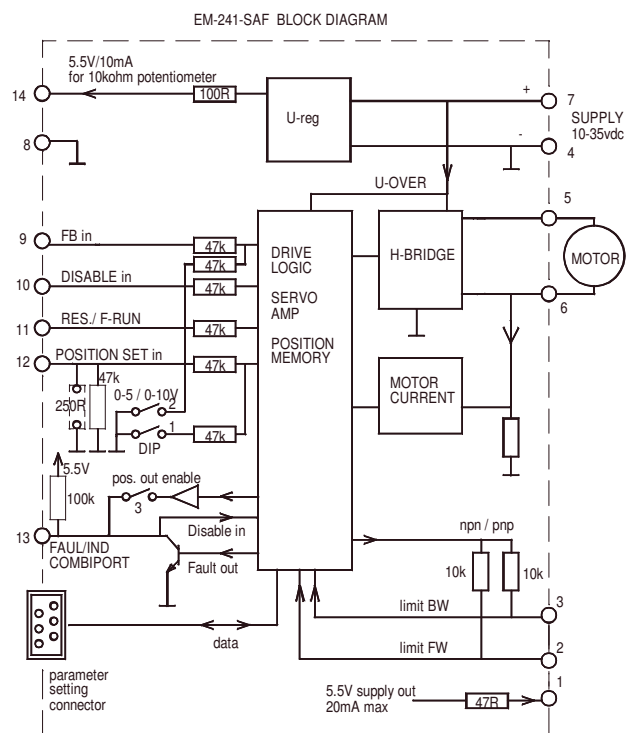

CONNECTION ADVISE

Supply voltage should be in the limits of 10-35Vdc. Ripple should be lower than 30% even with maximum load. NOTICES!

1. Wrong supply polarity can damage the device.
2. There is no inbuilt fuse in this device. So use an additive outside fuse and choose it according to your application.
3. The meaning of the terminals can change when changing the parameters (pls.see the parameter list and explanations).

TAKING IN TO USE

The setting of the driver is done with parameters, and the parameters can be set and edited with EM-236 Interface Unit. This makes changing easy and precise. Also the copying of the same parameters to multiple units is simple and same time accurate. The same parameters that are saved to one unit can be copied to an other unit with just one push of an button. Start by checking and setting the hardware related parameters. After that the actuator can be connected and operation fine tuned with other parameters.

Control range setting

Options for max. ranges are 0 to 5,5V, and 4 to 20mA if you place a 250ohm resistor to the resistor socket on the driver board. Using 0 to 11V range requires you to set the DIP switch 1 to "ON" position.

An individual control scale you can either set with parameters 21 and 22 as Volts or you can let the driver to measure your min. and max. control values. If you choose to set the min. and max. as Volts, pls. notice that the values are in ratio to the lowest range 0-5,50V, and with 0-11V range you have to divide the actual voltage with two. With current signal you should use the 0-5,5V range, and the right value can be calculated $I \times 250$. Eg: 4-20mA = 1,0 - 5,0V. Most precise way is to let the driver to measure the values. So first connect and adjust minimum value to set input (pin.12) and change the par.21 to val. 551. After value stops blinking the display shows the measured value. Then adjust the maximum control value to pin.12, and change par.22 to 551. After a while you will see the measured value in display. Always remember to save with long push to save button, before disconnecting EM-236 and taking power off from the driver. Notice: If control min. value is set higher than max. value the movement range will be inverted and set accordingly.

Feedback

Feedback range is always 0 to 5,5V as default. By setting the dip switch 2 to "ON" the range can be multiplied to 0 - 11V.

If the actual feedback signal can not reach the ends of the default range, parameters 23 and 24 can be used to accommodate the ranges. Setting the inner and outer software limits to suitable percentage values will compensate the narrow control signal range to the default range.

Forced run (F-run)

Forced run enables the motor to be driven to the mechanical end. That means that the motor or actuator can be driven beyond the determined software limits. The SW-limits are used to determine the operational movement range. But the parameter 14 value and the use of F-run will enable the wider driving range for service use or for use in some special situations of the application. F-run is started with a long command (>5s) to pin 11. The F-run speed is determined with parameter 5 and the driving is stopped with current trip or limit switch that cuts off the motor current. Motor will return to its servo position right after the signal to pin 11 disappears. Notice. The same pin 11 is used also as a reset input with short command (<5s).

Positioning dynamics

Dead zone (par.17) is to determine the accuracy of positioning. This parameter has the major effect to positioning accuracy. The smaller it is determined the more accurately the positioning is done. Notice. If it is set too small compared to accuracy level of the mechanics an oscillation or instability in positioning will occur.

Braking zone (par. 18) is used to optimize the time needed for positioning. Too high value slows down too early, and too low value will cause a fast position passing and needs a corrective return driving.

Start and stop ramp (par. 19 & 20) are to smoothen the direction change. Often suitable value for stop ramp is half of start ramp. Too long stop ramp can make the direction change too time consuming and too short can cause mechanical stress and non desired aggressivity.

Load compensation (par.11) when set to right value, will ensure the needed force to start driving and to taking the load in to the right position. With high load and too low load compensation value, the motor dont have force enough to reach the right position. Start testing with zero value and increase value until motor behaves unstable and twitching. Thumb rule in this point is to decrease the value with 25%.

Current limits (par. 6 and 7)should be set according to the motor nominal max. current or according to the required current of the application.

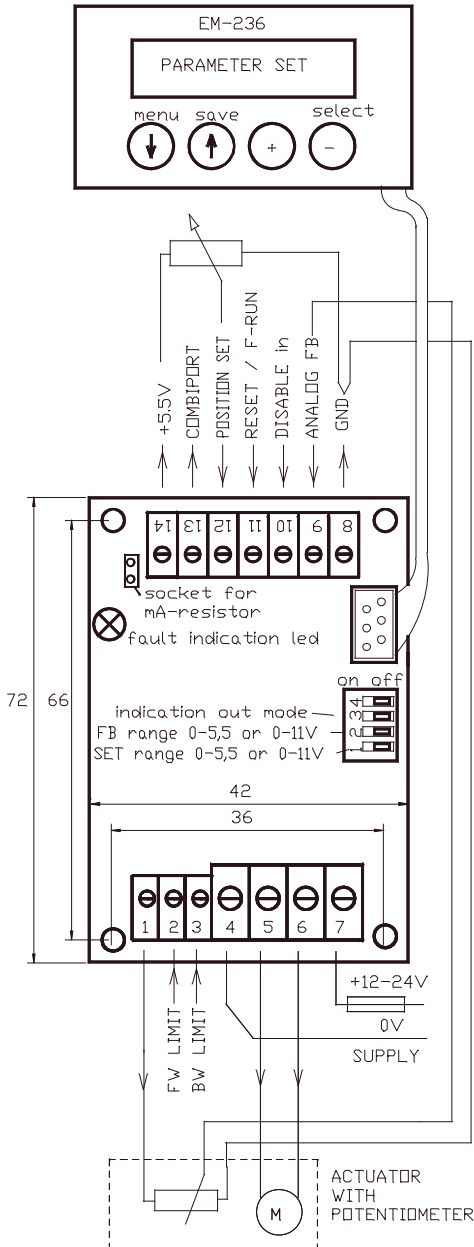

Indications

Fault situations are indicated with coded blinking of a red LED. Fault alarm can be forwarded out through combiport (pin.13). Fault situation is reset with a short (<5s) command to RES/F-run input (pin.11).

Some faults are reset automatically with a new position command to opposite direction. Instead of fault indication the combiport can be set to inform the status of the positioning as an "on position" output, or it can be set to give an analog position indication with 0-5V or 0.5-4.5V signal. Configuration of the combiport is done with par.9. Notice: If it is set to give analog information out (par.9 val3/4), also the DIP-switch 3 should be set to ON position. If combiport (pin 13) is selected to be fault output (par.9 val.1), it will also work as fault-disable input when externally pulled down.

Adjustments and settings

Parameter setting is done with EM-236 Interface Unit which is connected to a powered controller unit through the red connector. During the start up routine the Interface Unit will display information about itself and then the name and program version of the target device (driver which it was connected to). Then it will stay on displaying EDIT & LOAD. Pushing the "yes" button will upload and show the parameter list of the driver. Now the user can scroll the list with arrows, and make value changes with + and - buttons. Changed value is effective after few seconds when the display stops the blinking. But notice, that the change will not be saved until you give a long press (>5s) with the "save" button. This will save the changed list also to the EM-236s memory. Now it is easy to copy the same parameters to the next driver. Just connect the unit to the next powered driver and after start up routine just press a long "save". You can repeat this until all needed units have been set.

LIST OF PARAMETERS prog. v1.1 (defaults in parentheses)

- 1 No function (0)
- 2 Limit input logic (1)
 - 1= PNP
 - 2= NPN
 - 3= PNP inverted
 - 4= NPN inverted
- 3 Speed FW: 20-100% / 0-100 (100)
- 4 Speed BW: 20-100% / 0-100 (100)
- 5 Speed for F-driving: 20-100% / 20-100 (60)
- 6 Current limit out, FW: 0.1-20A / 1-200 (30)
- 7 Current limit in, BW: 0.1-20A / 1-200 (30)
- 8 Current tripp delay: 0-255ms / 0-255 (20)
(0=tripp not in use)
- 9 Combiport (pin 13) function: 1-4 (1)
 - 1= used as Fault in/out
 - 2= gives the "on position" information with 0V
 - 3= gives position indication with 0-5V
 - 4= gives position indication with 0.5-4.5V and fault =0V
- 10 Over voltage limit: 15-40V / 15-40 (35)
- 11 Load compensation: 0-255 / 0-255 (0)
- 12 Time out cut-off: 1-255s. / 1-255 (0= not in use) (0)
- 13 Hour and start counter reset (0)
set value = 1 and press save -> counters are set to zero
- 14 Forced run function with >5s command to pin 11 (1)
 - 1= makes F-run to BW direction
 - 2= makes F-run to FW direction
- 15 Fault reset conditions 0-1 (1)
 - 0= reset with RESET-input or opposite direction request.
 - 1= fault reset can be done only with RESET-input (pin 11)
- 16 No function (0)
- 17 Dead zone : 0,2-5% / 2-50 (10)
- 18 Braking zone : 1 - 8% / 1 - 8 (3)
- 19 Start ramp : 0,1-2,5s / 0-250 (10)
- 20 Stop ramp : 0,1-2,5s / 0-250 (3)
- 21 Set value min. 0...5,50V / 0-551 (0)
- 22 Set value max. 0...5,50V / 0-551 (550)
- 23 Inner (BW) SW-limit: 0...-50% 0-500 (5)
- 24 Outer (FW) SW-limit: 0...+50% 0-500 (5)

FAULT LED -blinking codes

- | | |
|----------------------|----------|
| 1. l-trip | 1 blink |
| 2. time out trip | 2 blinks |
| 3. over temperature | 3 blinks |
| 4. over voltage trip | 4 blinks |

Pls. notice:

when card is powered the LED- blinks onse.

MONITORABLE VALUES (Can be read with EM-236)

- | | |
|------------------------------------|---------------------------|
| 1 fault code | (see the fault code list) |
| 2 motor current | 0-20A (0-200) |
| 3 target position | 0-100,0% (0-1000) |
| 4 realized position | 0-100,0% (0-1000) |
| 5 hour counter | (max.65535h) |
| 6 start counter | (max.65535 starts) |
| 7 start counters over flow counter | (max. 65535) |

ABOUT PARAMETERS

- 1. No function.
This parameter position is not in use in this program.
- 2 Limit switch input terminals (pin 2 and 3) can be set to work with positive or negative logic. Positive =PNP, negative=NPN. The effect can also be inverted so that when signal is ON status is OK, and signal OFF status is "disable by limit".
- 3 & 4 are for speed setting of FW (out) and BW (in) directions.
- 5 the speed setting for "Forced run" (F-run).
- 6 & 7 current limit setting for FW (out) and BW (in) directions
- 8 determines the time the current is allowed to be on the limit value before driving is cut off (driver trips off). Value is in milliseconds and if set to "0", the current tripping feature is disabled.
- 9 Configuring the combiport functions (pin 13). This terminal can work as combined input-output for fault. Or it can give a "position OK" signal after successful positioning. It can also be used to indicate the position with a continuous voltage signal (position signal). If position signal is chosen (val 2 or 3) the DIP3 must be set to "ON".
- 10 Over voltage protection switches the motor to free wheel. This saves the controller or other devices in supply line from over voltage in case the motor generates energy during slowing down or braking. This can happen with eg. in vehicle or lifting applications.
- 11 Load compensation (Rxl-comp) enables good motor torque even with low speeds. It is good to start testing with zero value, but if the motor seems weak when starting with normal load, the value can be increased step by step until there is power enough to start. Notice: Too high value is recognized from oscillation and/or twitching, If it is not possible to see the behavior of the motor and test the effect with momentary loading of a freely running motor the safest value for this parameter is zero.
- 12 Time out tripp will cut off the driving if continuous driving to the same direction exceeds the set value (statet in seconds).
- 13 This parameter is for resetting the start and hour counters. Saving value 1 will set to zero the drivers start and hour counters.
- 14 Parameter for choosing the forced run direction. F-run is started with long >5s command to RES/F-run terminal (pin 11)
- 15 Determines how the controller recovers from fault situation. Val 0. Recovers also with an opposite direction movement request. Val 1. fault requires a short (<5s) reset command to pin 11.
- 16 No function. Value of this parameter position has no effect.
- 17 Dead zone for determining the wanted positioning accuracy. If this window value is small the positioning is tended to be done more accurately. If value is too small the application is not capable to exceed this accuracy, and can not find or maintain the set position steadily. In this case the value should be increased.
- 18 Braking zone value is determined as a percentage of the full movement range. It determines how early driver starts to slow down before reaching the right position. Main rule is that small value for slow applications and high value for fast applications.
- 19 & 20 Start and stop ramps are used to smoothen the speed and direction changes. The parameter value is the time from 0-100% and from 100%-0 speed.
- 21 & 22 are for determining the control signal range limits. Value can be given as Volts, 0 to 550 (0 to 5,5V). The values can also be measured automatically by setting the parameters to value to 551. The card will then measure the range min. and range max. voltages on the POSITION SET input. Pls. read also the chapter "Control range setting".
- 23 & 24 Inner (BW) and outer (FW) SW-limits. With these adjustable limits the movement range can be limited to suite the application. Notice: the forced run will over drive these points.

EM-241-SPF POSITIONING DRIVER 12-24V 15A



FEATURES

- quadrature pulse counting
- multiple dynamic settings
- solid state power stage
- one or two pulse feedback
- voltage or mA control
- position accuracy max. 0.2%
- versatile setting options
- digitally settable parameters
- housing options available
- CE marked product

EM-241-SPF is a positioning driver to be used with DC-motors. The solid state power stage operates with high efficiency and as its realized with FET-transistors. Its literally everlasting compared to relay solutions. Feedback is done with one or two line pulse signal. Although position feedback can be done with one pulse line it is always preferred and more secure to do it with two 0°/90° pulse lines. This driver includes an analog control with three signal ranges, 0-5.5V, 0-11V or 4-20mA. Input is freely scalable inside the range. The max. electrical accuracy of the driver and feedback is 0.2% which is adequate for most actuator positioning applications.

The settings and adjustments are done with parameters as in all new generation Electromen products. Included in the parameters is also the learn routine which will help to determine the full movement range fast and easily. Additively the movement range can be modified from both ends with SW-limit parameters. Possible cumulating pulse count errors can be avoided with manually or automatically triggerable home drive. Current limits and driving speeds can be set individually for both directions. Driver includes also many other dynamic adjustment features like parameter for load compensation, dead-zone setting (positioning window), start and stop ramps for smooth direction change and braking zone for well operating positioning.

The parameter setting and status monitoring is done with EM-236 Interface Unit. With EM-236 the right parameters can also be copied easily to other driver units. The on-board LED-light indicates the possible fault situations with blinking codes. If needed, the fault alarm can be also given out trough combiport (pin. 13). This port can be set as "position OK." output or it can work as an analog position signal output. Additively it can work also as disable input. Device is EMC tested for industrial and household environment and operating temperature range is quite wide. There are also same housing options available for EM-241-SPF driver card as for the standard EM-241.

TECHNICAL DATA

Supply voltage	10-35V
Shut down voltage	8V
Power up voltage	9V
Motor current cont.	15A, mom. 30A (Ta<50°C)
Current limit	0.1-20A (in start max. 30A)
Overtemp. limit	100°C
PWM frequency	2kHz
Pulse sampling rate	0.2ms
Input freq. of pulse lines max	1kHz
Control input ranges (position)	0-5.5V / 0-11V / 4-20mA
Positioning potentiometer	10k recom. 22k max.
Input resistor for mA-signal	250ohm (socket on board)
Position out. signal range	0-5V or 0.5 - 4.5V, 0V for FAULT
Digital input levels	high =4-30V, low=0-1V
Digital input impedances	typ. 47kohm
Limit-FW / -BW and pulse inputs	imp. typ 10kohm
COMBIPORT pin.13	
- Fault output, NPN, open coll.	max 30V / 1A
- Disable -in □	Uin < 1V (NPN)
- Indication out impedance □	1kohm
Connectors for motor and supply	max. 2.5mm² cable
Connectors for signals	max. 1mm² cable
Operating temp(Ta)	-40...60°C
Dimensions	72x42x25mm
Weight	80g
CE-tested for household and industrial environment (EMC)	EN-55022B, EN-61000-4-3, -4, -5, -6 passed

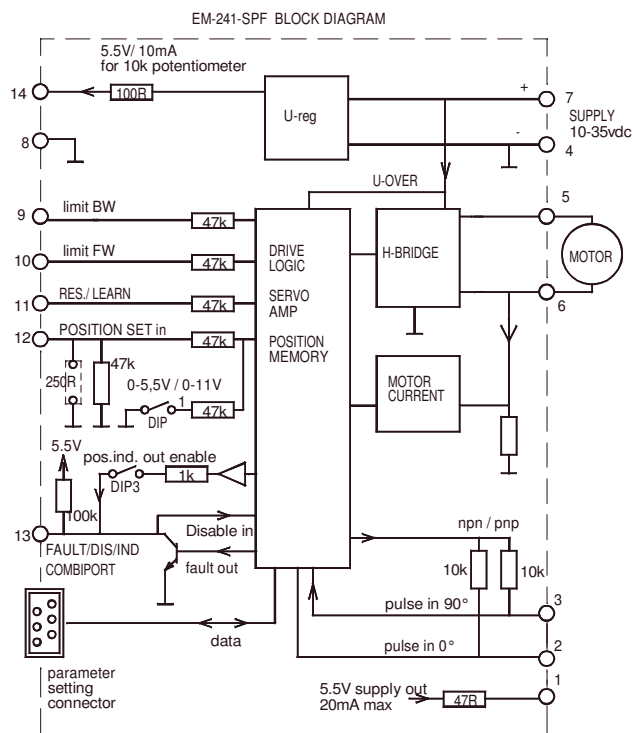

CONNECTION ADVICE

Supply voltage should be in the limits of 10-35Vdc. Ripple should be lower than 30% even with max. load. **NOTICES !**

1. Wrong supply polarity can cause damage the device.
2. There is no inbuilt fuse in this device. Use an external fuse which is chosen according to your application.
3. that function and scale of some of the input and output terminals is depending on the selected parameter values and defined ranges. Please, see the parameter list and explanations.

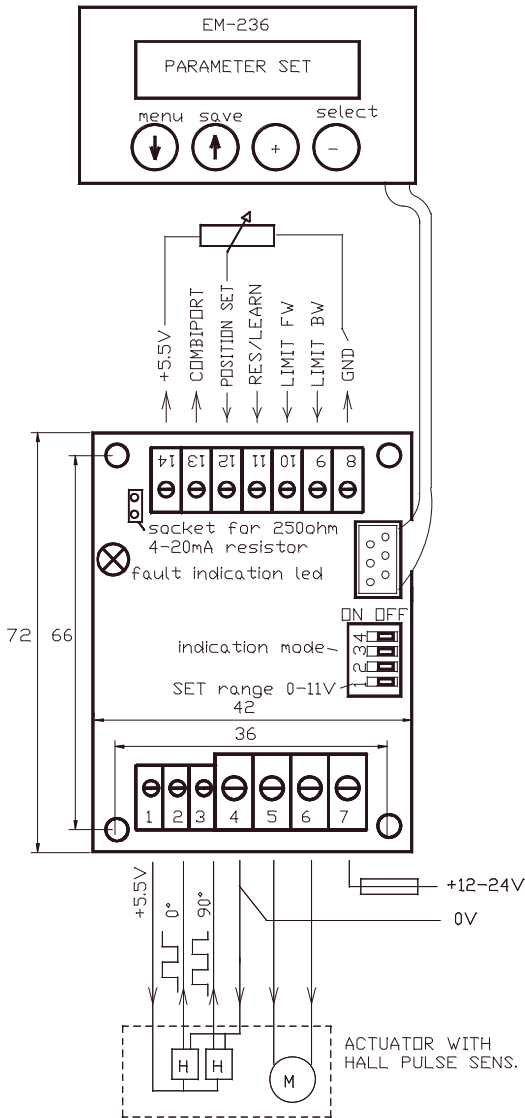

Pulse edges of 1 and 2 pulse lines

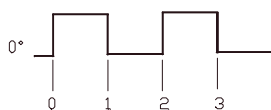

One pulse mode includes no direction information

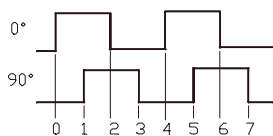

Two pulse, quadrature pulses offers also the direction information

TAKING IN TO USE

The setting of the controller is done with parameters, and the parameters can be set and edited with EM-236 Interface Unit. Making changes is easy and precise. Copying the parameters to multiple units is simple and accurate. The same parameters that are saved to one unit can be copied to another unit with one push of a button. After the two first parameters have been set according to the application, the actuator and control wires can be connected and operation can be adjusted with the remaining parameters.

Position feedback

Select 1 or 2 pulselines with parameter 1 according to your application. The position information has more risk to be corrupted when controller is used with one pulse line, as the signal does not have information about the direction of the movement. For example in fast direction change with difficult loads few pulses are more easily counted to wrong direction. So it is recommended to use two pulse lines (0° and 90°) when ever available.

Full range

Full range is the full mechanical movement of the linear motor or positioning system. At first it is always needed to determine the full range before it is possible to drive the system. When the full range is determined it is also set to correspond the selected and set control range that can be for example 0-5V. Position feedback is received as pulses, and full range is determined as the number of pulse edges received during the full movement from start to end. If this number is known it can be set as the value of parameter 25 (Full range).

Home run

The position feedback is received as pulses so the driver can not know the high position before its pulse counter is reset in some known position. Home run command will drive the motor to selected end of the full range and there it will reset the pulse edge counter. Before the positioning can be used the home run must be done. After home run the position is saved to the drivers memory and will be valid even after the power is cut off and restored. Home run is configured with parameter 14, values 1 or 2.

Learn routine

Learning is a special option for finding the full range and taking the system in use with out knowing the number of pulses for full range. Learn routine is selected with par.14 val.7. and started with 5s command to RES/LEARN input. Learn routine will drive the motor forward (FW) until it reaches the outer end then it starts the motor backwards (BW) and drives to inner end. During this routine the driver "learns" the number of pulse edges for full range and also retrieves the absolute position by resetting the counter in the inner end. After learn routine is done the driver can be used for positioning and par 14 should be set to some suitable value for normal use of the application. Notice: Learn routine is ran to the hard end (or to the limit switches if wired). Notice: To see the learned and right number of the full range pulse edges, you have to down load (OK to Load&Edit) the parameters from driver with EM-236 Interface Unit once again. Or if you are viewing the par.25 while learn routine you can try to change the value and the EM-236 Interface unit will first display the learned range. After this its possible to edit this reading.

Auto home

Auto home is an automated home run that is triggered during normal operation when ever the motor is run to the FW or BW end switch or close to the software end limit (SW-limit). Well configured auto home can effectively prevent cumulating position error. Its specially useful when working with only one feedback pulse line. Auto home configures with par. 14 (values 3,4,5 or 6). Notice. The auto-home will be ran to the hard end (or to the limit switches if wired). If you choose the auto-home triggered from limit switch inputs or SW-limits, the option of using the 5seconds command to RES/LEARN input is also available.

Control range setting

Options for max. ranges are 0 to 5,5V, and 4 to 20mA if you place a 250ohm resistor to the resistor socket on the driver board. Using 0 to 11V range requires you to set the DIP switch 1 to "ON" position. Your individual control scale you can either set with parameters 21 and 22 as Volts or you can let the driver to measure your min. and max. control values. If you choose to set the min. and max. as Volts, pls. notice that the values are in ratio to the lowest range 0-5,50V, and with 0-11V range you have to divide the actual voltage with two. With current signal the right value is l x 250. Eg: 4-20mA = 1,0 - 5,0V. Most accurate way is to let the driver to measure the values. So first connect and adjust minimum value to set input (pin.12) and change the par.21 to val. 551, after value stops blinking the display shows the measured value. Then adjust the maximum control value to pin.12, and change par.22 to 551. After a while you will see the measured value in display. Always remember to to save with long push to save button, before disconnecting EM-236 and taking power off from the driver. Notice: If control min. value is set higher than max. value the movement range will be inverted and set accordingly.

Positioning dynamics (continued on the next page)

Dead zone (par.17) is to determine the accuracy of positioning.

This parameter has the major effect to positioning accuracy. The smaller it is determined the more accurately the positioning is done. Notice. If it is set too small compared to accuracy level of the mechanics an oscillation or unstability in positioning will occur.

Braking zone (par. 18) is used to optimize the time needed for positioning. Too high value slows down too early, and too low value will cause an fast position passing and needs a corrective return driving.

Start and stop ramp (par. 19 & 20) are to smoothen the direction change. Often suitable value for stop ramp is half of start ramp. Too long stop ramp can make the direction change too time consuming and too short can cause mechanical stress and non desired aggressivity.

Load compensation (par.11) when set to right value, will ensure the needed force to start driving and to taking the load in to the right position. With high load and too low load compensation value, the motor dont have force enough to reach the right position. Start testing with zero value and increase value untill motor behaves unstable and twitching. Thumb rule in this point is to decrease the value with 25%.

Current limits should be set according to the motor nominal max. current or according to the required current of the application (if lower than nom).

Indications

Fault situations are indicated with coded blinking of the red LED.

Fault alarm can be forwarded out trough combiport (pin.13).

Fault situation is reset with a short (<5s) command to RES/LEARN input (pin.11). Some faults are reset automatically with a new position command to opposite direction.

Instead of fault indication the combiport can be set to indicate the status of the positioning as an "on position" output, or it can be set to give an analog position information with 0-5V or 0.5-4.5V signal. Configuration of the combiport is done with par.9. Notice: If it is set to give analog information out (par.9 val3/4), also the DIP-switch 3 should be set to ON position.

If Combiport (pin 13) is selected to be fault output, it will also work as disable input when externally pulled down. If this terminal is selected to be used for indication the "disable in" function can be set and transferred to work trough limit input terminal pin 9 or pin 10 (par.15).

Adjustment and settings

Parameter setting is done with EM-236 Interface Unit, which is connected to a powered driver unit to the red connector. During the start up routine the Interface Unit will display information about itself and then the name and program version of the target device. Then it will stay on displaying EDIT & LOAD. Pushing the "yes" button will up load and show the parameter list of the controller. Now the user can scroll the parameters with arrows, and make value changes with + and - buttons. Edited value is effective after few seconds when the value stops blinking. But notice, that the change will not be saved untill you give a long push (>2s) to the "save" button. This will save the values to the EM-236s memory also. Now it is easy to copy the same values to a other driver. Just connect the unit to a powered driver and after the start up routine just press a long "save". You can repeat this untill all needed units have been configured.

LIST OF PARAMETERS prog. v1.3 (defaults in parentheses)

- 1 Feed-back mode : one-pulse=1, dual-pulse=2 (1)
- 2 Limit and pulse input logic (1)
 - 1= limit inputs PNP / pulse inputs PNP
 - 2= limit inputs PNP / pulse inputs NPN
 - 3= limit inputs PNP inverted / pulse inputs PNP
 - 4= limit inputs PNP inverted / pulse inputs NPN
- 3 Speed FW: 20-100% / 0-100 (100)
- 4 Speed BW: 20-100% / 0-100 (100)
- 5 Speed HOME/LEARN: 20-100% / 20-100 (60)
- 6 Current limit out, FW: 0.1-20A / 1-200 (30)
- 7 Current limit in, BW: 0.1-20A / 1-200 (30)
- 8 Current trip delay: 0-255ms / 0-255 (100)

(0 = tripp not in use)
- 9 Combiport (pin 13) function: 1-4 (1)
 - 1= used as Fault out / Disable in (fault/dis=0V)
 - 2= gives the "on position" data (on pos=0V)
 - 3= gives position info out with 0-5V
 - 4= gives position info with 0.5-4.5V and fault =0V
- 10 Over voltage limit: 15-40V / 15-40 (35)
- 11 Load compensation: 0-255 / 0-255 (0)
- 12 Time out: 1-255s / 1-255 (0= not in use) (0)
- 13 Hour and start counter reset (0)

set value = 1 and press SAVE -> hour and start counter reset
- 14 Home run / learn function: 1-7 (1)
 - 1= Home run with RES / LEARN input to BW direction (>5s. comm.)
 - 2= Home run with RES / LEARN input to FW direction (>5s. comm.)
 - 3= Auto-Home from BW LIMIT input to BW direction (pin 9)
 - 4= Auto-Home from FW LIMIT input to FW direction (pin 10)
 - 5= Auto-Home triggered with inner soft limit to BW direction
 - 6= Auto-Home triggered with outer soft limit to FW direction
 - 7= Learn routine with >5s command to RES /LEARN input (pin.11)
- 15 Disable input configuration (0)

0= Disable only to pin.13, 1=disable to pin.10, 2=disable to pin.9
- 16 Not in use
- 17 Dead zone : 0,2-5% / 2-50 (10)
- 18 Braking zone : 1-8% / 1-8 (3)
- 19 Start ramp : 0.1-2.5s / 0-25 (10)
- 20 Stop ramp : 0.1-2.5s / 0-25 (3)
- 21 Set value min: 0...5.50V / 0-551 (0)
- 22 Set value max: 0...5.50V / 0-551 (550)

For parameters 21 and 22 value 551 will do an auto setting
- 23 Inner (BW) SW-limit: 0...+50% / 0-500 (5)
- 24 Outer (FW) SW-limit: 0...-50% / 0-500 (5)
- 25 Full range (pulse edges) 100-65535 / 100-65535 (1000)

FAULT LED -blinking codes

- | | |
|---------------------|---------|
| 1. I-trip | 1 blink |
| 2. pulse lost | 2 blink |
| 3. over temperature | 3 blink |
| 4. over voltage | 4 blink |
| 5. time out trip | 5 blink |
| 6. learn corrupted | 6 blink |

MONITORABLE VALUES (Can be read with EM-236)

- 1 fault code (see above) 1-6
- 2 motor current 0-20A / 0-200
- 3 target position 0-100,0% (0-1000)
- 4 realized position 0-100,0% (0-1000)
- 5 position as pulse edges 0-65535
- 6 hour counter (max.65535h)
- 7 start counter (max.65535)
- 8 start counters over flow counter (max. 65535)

ABOUT PARAMETERS

1. Feedback mode is a mandatory setting to be done according to the application. 1= for one pulse line only, 2= two pulse lines for 0° and 90° pulses.
2. Limit and pulse inputs (pins 9, 10, 2 and 3) can be set to work with positive or negative logic. Signal can be either pulling up =PNP or down to 0V which is often marked as NPN signal.
- 3 & 4 driving speed to FW (out) and BW (in) directions.
- 5 The speed setting for "home run" and "learn" routines.
- 6 & 7 Current limit setting for FW (out) and BW (in) driving directions.
- 8 Current tripp delay time 1-255ms, if set to 0 the tripp is disabled
- 9 Combiport configuration (pin 13). This terminal can work as combined input-output. It can be fault output and disable input or an on position indicator giving an "on position" signal after a succesfull positioning. It can also be used to indicate the position with continuous voltage signal 0-5V (val.3) or 0.5-4.5V + 0V fault (val.4).

Notice: With val. 3 or 4, also the DIP3 must be set to "ON" position.
- 10 Over voltage limit. Motor is switched to free wheel if the selected voltage level is exceed. This saves the driver or other devices in supply line from over voltages in case the motor generates surplus energy during slow down or braking.

This can happen eg. in vehicle or lifting applications.
- 11 Load compensation (Rxl-comp) ensures good torque with low speeds. It is good to start testing with zero value, but if the motor seems weak when starting or slowing down to the right position this value can be increased carefully and step by step.

Notice: Too high value is recognized from oscillation and/or twitching.
- 12 Time out tripp will cut off the driving if continuous driving to the same direction exceeds the set value (statet in seconds).
- 13 Usage counter reset parameter is for manual reset of counters. Choosing and saving value 1 will reset the hour and start counters.
- 14 Home run direction and start condition setting or enabling the learn routine for finding the full movement range.

Home run can allways be started with RES/LEARN input (pin 11). Auto home can be started with actual limit switch inputs or with so called SW-limits (par. 23 and 24). Last special option (value 7) is for starting the learn routine. That is an end to end drive routine to count and determine the real full movement range.
- 15 In case the pin.13 is used for indication, the limit switch inputs pin 9 or 10 can be configured to work as disable input.
- 16 Not in use in this program version.
- 17 Dead zone is for determining the suitable positioning accuracy. If this positioning window value is small the positioning is tended to be done more accurately. If value is too small compared to the accuracy of the other parts of the application, the system might not be able to work properly. Notice. Other parameters like braking zone and FW/BW speed settings will also affect to the positioning behaviour.
- 18 Braking zone value is determined as a percentage of the full movement range. It determines how early driver starts to slow down before reaching the right position. Main rule is that small value for slow applications and high value for fast applications.
- 19 & 20 Start and stop ramps are used to smoothen the speed and direction changes. Its the time from 0-100% or from 100%-0 speed.
- 21 & 22 are for determining the control signal range limits. Value can be given as Volts, 0 to 550 (0 to 5,5V), or the min. and max. values can be measured automatically by setting value to 551. Then the card will measure the signal in the POSITION SET input. Pls. read also the chapter "Control range setting".
- 23 & 24 Inner (BW) and outer (FW) SW-limits. With these adjustable limits the movement range can be limited to suite the application.

Notice: if either of these SW-limits is used for auto-home (par.14) the motor will drive over the limit when executing the home run.
- 25 The full-range is determined by setting the known or calculated full range pulse edge count to be the parameter value. Alternatively the value can be defined by making the learn run (par.14 val.7)

Notice. The learned pulse edge number is up dated to the EM-236 Interface unit display when you make a new Load & Edit data query or try to change the value right after learn routine. to change

EM-160 DC-MOTOR SERVOCONTROLLER 12-32V 12A 4-QUAD



FEATURES:

- Small size
- Positioning precision 1/400
- Four drive quadrants
- High efficiency >92%
- For motors 10-300W
- Rail mounting base fittable
- Adjustable current limit
- Adjustable output current
- Adjustable positioning window
- Settable maximum speed

EM-160 is a motor controller for permanent magnet DC-motors. The unit is primarily designed for positioning usage, where position information is derived from potentiometer or as voltage, for example spindlemotors equipped with potentiometers. The unit is so called four quadrant controller, in other words it drives and brakes in both directions. The braking is regenerative by nature as it feeds braking energy back to power source. If the power source is not a battery the unit will feed braking energy to motors internal resistance. EM-160 has a window comparator, which measures the difference between feedback and reference value and uses this to control the motor. The unit has an adjustable positioning window, that specifies the level of difference to occur for correction to take place, in other words the precision of positioning. Range and zero -trims can be used to match the reference value with feedback value. Using the start level adjustment the minimum motor voltage can be suited for the application. Too low start level will result in motor warming and increased current consumption as a consequence of the motor not being able to perform small corrections due to lack of power. Too high start level will cause too rapid corrections or oscillation. Motor current can be limited using motor current adjustment. It is possible to switch current limit into so called trip mode in which current limitation will switch off drive. If the current limit has been exceeded for one second, the unit won't be active until driven into opposite direction. The power stage is protected against voltage peaks, overload and momentary shortcut. Reversed polarity connection should be avoided even though the unit is equipped with a fuse.

TECHNICAL DATA

Supply voltage	12-32Vdc
Idle current	< 30mA
Fuse	30A "ATO"
Load capacity	12A "ATO"
	20A mom. (8s/30s)
	25A mom. (2s/30s)
Current limit	3-30A
Operating freq.	approx. 22kHz
Control voltage	0-5...0-10V
Control potentiometer	1kohm...10kohm
"stop" control	>4V "stop"
	<1V or open "drive"
Trip-indication output	NPN -open coll. 30V / 100mA
Input imp.	pins 6 and 9 = 50kohm
	pin 8 = 35kohm
Efficiency	>92%
Operating temp.	-10...50°C
Dimensions	(88 x 72 x 30) mm
Weight	approx. 110g

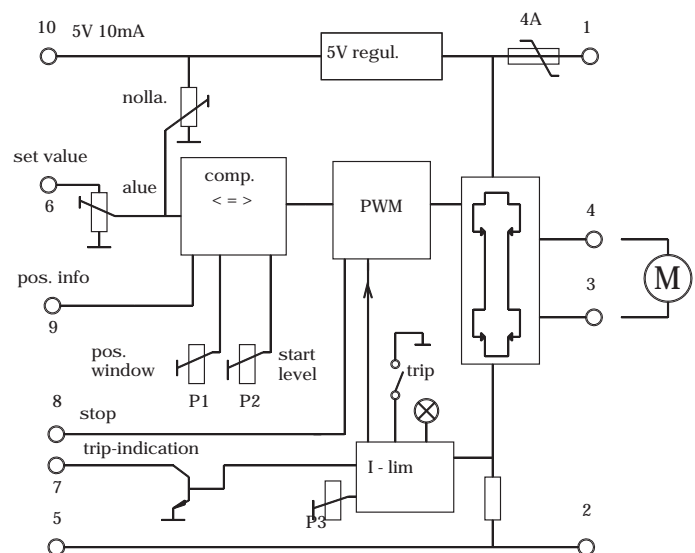

EM-160 USAGE

IMPORTANT !!

Supply voltage filtered (<20% ripple)
12-32VDC.

!! Check the polarity before connecting.

ADJUSTMENTS

Recommended start values in brackets.

START LEVEL (25%)

Adjustment sets motor start level.
Start level should be set so that motor always starts reliably but not too rapidly.

CURRENT LIMIT (= motor nominal current)

Set max. motor current (moment).
A red led indicates the activity of current limit.
At first it's recommended to set current limit low and increase the current to suitable level when the application seems to work.

POSITIONING WINDOW (2%)

Sets so called positioning window dimension.
Suitable value depends on the mechanics of the application. First set to the maximum, then decrease until application starts twitching, then set backwards until twitching ends. START LEVEL and WINDOW adjustment affect each other a little. To obtain best possible precision and positioning window start level must be precisely convenient.

RANGE AND ZERO

Use these adjustments to match reference and feedback values. For example, when using 100mm spindlemotor with only 70mm needed. Range adjustment is used to set frequency and zero for position, for example center. NOTICE that range adjustment also affects zero. Zero doesn't affect range. If these adjustments are inadequate external series resistors can be added to feedback potentiometer.

RANGE RESISTANCE (2.2k) (maximum speed)

Resistors are used to optimize the operation in specific voltage range.

- 1.8k 28V application
- 2.2k 24V application
- 3.3k 18V application
- 4.7k 12V application

EXAMPLE 1

Basic application where both set value and position value is derived from potentiometer.

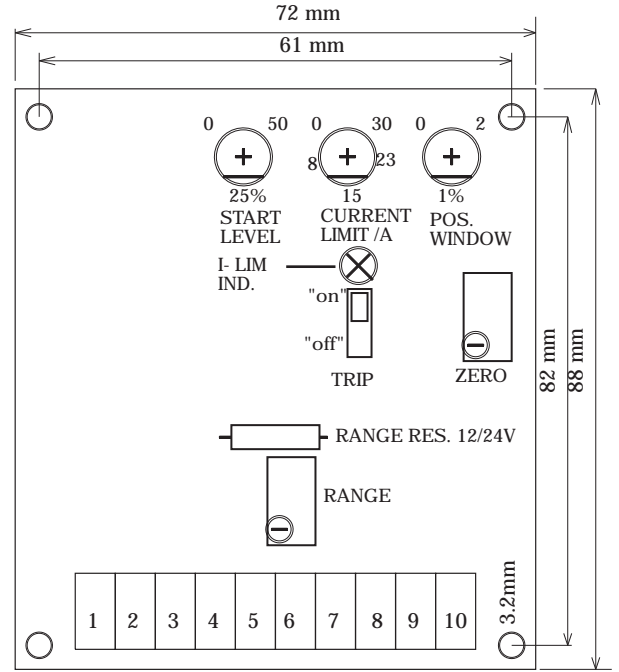
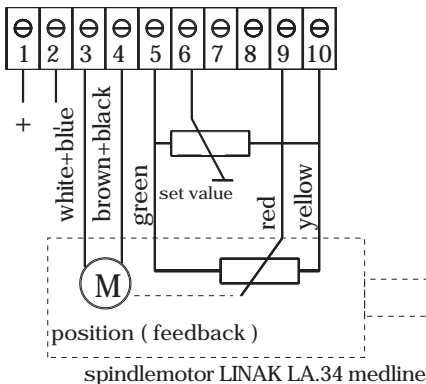

TERMINALS

- | | |
|--------------------------|---------------------------|
| 1. Supply voltage 12-32V | 5. Signal gnd (0V) |
| 2. Supply voltage 0V | 6. Set value in |
| 3. Motor out - | 7. Trip indication 100mA |
| 4. Motor out + | 8. Stop |
| | 9. Position feedback in |
| | 10. 5V 10mA reference out |

INTRODUCTION

Connect the application, adjust set value to approximate center. Switch on, application should seek its way to a certain point. Change the set value and position should change accordingly, if the application runs from one end to the other exchange motor leads with each other (3 and 4). Adjust the precision and dynamic to suit your application as described before.

EXAMPLE 2

In this application set value is given in voltage, and position from potentiometer.

