



# elap

## Magnetic Transducer TM + MP200

The linear magnetic measuring system **TM+MP200** is composed by the magnetic transducer **TM** and the magnetic band **MP200**:

The transducer works contactless, relieving the polarized fields of the magnetic band and converting the measure into digital signals.

The system can be profitably employed in severe industrial environments, in presence of water, oil, grease. The mounting method is easy and cheap and the measure is accurate and repeatable.

The scanning head **TM** is contained in a compact and strong metal case, and it is available with reading resolution 0.1 mm (**TM10**) or 0.01 mm (**TM100**).

An electronic zero pulse is generated each 4 mm (type **TM10C/TM100C**), or matching with one or more external magnets (**TM10E/TM100E**).

**Complying with CE standards**

### Magnetic Band MP200

The magnetic band **MP200** consists of a plasto-ferrite strip, which is polarized at regular distance, and supported by a stainless steel carrier; it is equipped with the adhesive tape for an easy mounting.

As an optional, the magnetic band can be supplied with a magnetically transparent stainless steel cover for physical protection.

### Reading Transducer Specifications

TYPE	TM10C/TM10E	TM100C/TM100E
Reading resolution	0.1 mm	0.01 mm
Accuracy	± 0.1 mm/m	± 0.05 mm/m
Electronic zero pulse	each 4 mm (type C) or matching with external magnet (type E)	
Frequency	32.5 KHz	250 KHz
Sensor distance	0.3 ÷ 1.2 mm	
Phase difference	90° ± 5° electrical degree	
Max. speed	13 m/s	10 m/s
Vibration resistance	(10 Hz + 2 KHz) at 100 m/s <sup>2</sup>	
Shock resistance	1000 m/s <sup>2</sup> (11 m/s)	
Protection degree	IP67	
Operating temperature	0 ÷ 70° C	
Stocking temperature	-20° ÷ 80° C	
Humidity	100% non condensed	
Supply	5 Vdc ±10% 25 mA 10÷30 Vdc 15 mA	5 Vdc ±10% 65 mA 10÷30 Vdc 40 mA
Output signals	Push-pull or line-driver	
Standard cable	Length 2 m	
Electrical protections	for the supply: against polarity inversions for the outputs: against short circuits	

### Magnetic Band Specifications

Pole pitch	2 + 2 mm
Accuracy	0.1 mm
Width	10 mm
Thickness	1.3 mm
Max. length	50 m
Thermal expansion	10.5x10 <sup>-6</sup> °C <sup>-1</sup> ref.t.=20°C±0.1°C
Operating temperature	0 ÷ 70°C
Stocking temperature	-20° ÷ 80°C

### DIMENSIONS

Magnetic Transducer **TM** +  
Magnetic Band **MP200**

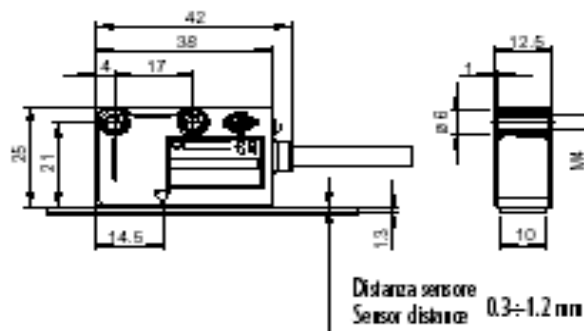

elap

s.p.a. Via Vittorio Veneto, 4 - I-20094 CORSICO (MI) - Tel. ++39.02.4519561  
Fax ++39.02.45103406 E-mail: elapsa@tin.it URL: www.elap.it