

Hybrid Stepper Motors & Brushless Motors

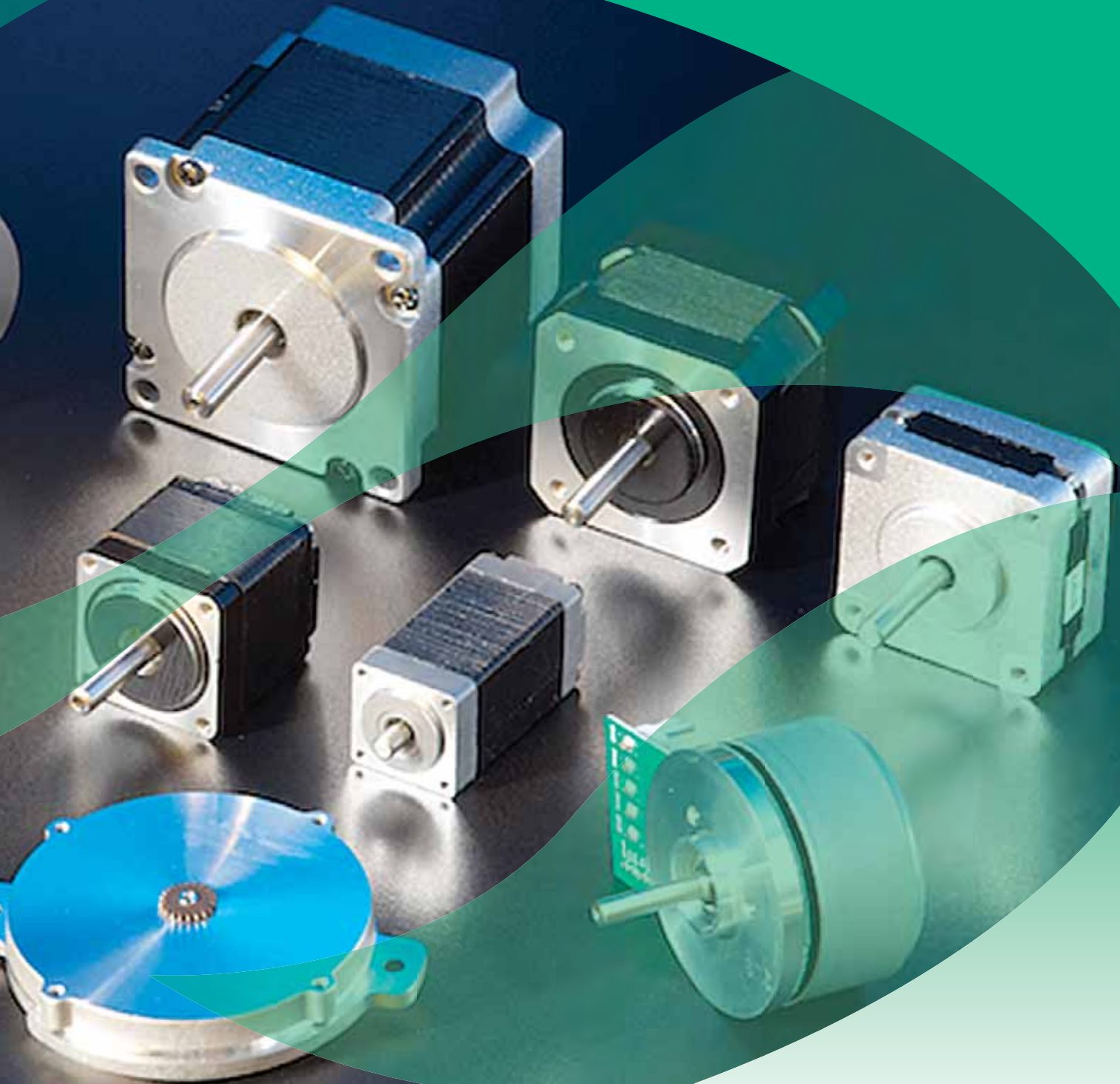

www.motiontech.com.au





Philosophy

Changzhou Fulling Motor Co. Ltd. is an ISO9001 professional manufacturer

As a joint venture of Germany-Italy-China, Changzhou Fulling Motor Co., Ltd was established in year 2000. We are a professional motor manufacturer in Changzhou city, China. Production capacity exceeds more than 2 millions motors per year. Our Company offers three major series of products: Hybrid stepper motors, DC brushless motors and the motor driver.

Changzhou Fulling Motor Co., Ltd also has several joint venture companies who specialized in the production of AC Servo motor, PM stepper motors, AC motors, DC brush motors and DC gearmotors. We sell nearly 5 million motors from our joint venture partners to customers Worldwide every year. We export our motors to more than 30 countries such as Italy, Germany, United States and Russia.

The Fulling product line is sold to major manufacturing Companies for Industry of automation, medical and health care equipment, printer machines, packing devices, Information Technology, household appliance products, and automobile.

We have an Engineering team with many years of experience in application Engineering, design Engineering with the latest advances equipment. Our Engineering Staff provides the finest quality product with service after the product is delivered to our Customers.

Changzhou Fulling Motor Co., Ltd obtained its ISO9001:2000 certification and TS16949 certification authorized by TUV Company in Germany, most of our products are CE, UL approved.

Our Company adheres to principles of "providing green products" and all of our products are RoHS compliant.

As a global supplier, Changzhou Fulling Motor Co., Ltd scrupulously follows the guideline of International Commercial Rules and Practices. We have achieved our reputation of cooperation with our Customers over the years. Our Goal is to "Win the market with quality and service" which is the common voice of every Changzhou Fulling Motor team member.

20 years experience behind our stepper & DC Brushless motors. Working together, growing together!

Quality

Fulling Motor provides 100% quality control during manufacturing process. This process incorporates quality checks on every item after every manufacturing process, from parts acceptance to the finished product. Every **Fulling Motor** product undergoes reliability testing before it is released to the market.

Delivery

Fulling Motor production system allows the processing of an order with little notice, in any quantity requested. Additionally, **Fulling Motor** uses a "one-by-one" process where one item can be manufactured as simply as one thousand items. Over 100 of **Fulling Motor** standard products are available on stock for fast prototypes delivery.

Web

The **Fulling Motor** website is a valuable tool for a design engineers to gather information. There you can find specifications on all our products, download PDF files or check the latest news.

www.fullingmotor.eu

Move innovation



Peripherals - Office automation - Telecommunication - Reprographic and printing machines - Machine tools - Industrial automation - Machines for wood working - Car instruments and servo controls - Sewing machines - Machines for textile and clothes sectors (knitting, shoe) - Machines for farm and food industries - Machines for packing and wrapping laboratory, measuring, electromedical instruments - Spot lights for amusement



Table OF contents



Stepper MOTOR

20SH	20mm 1,8° High Torque Hybrid Stepper motor	6
25SH	25mm 1,8° High Torque Hybrid Stepper motor	7
28SH	28mm 1,8° High Torque Hybrid Stepper motor	8
28S10	28mm 1.8° FLAT Hybrid Stepper motor	11
35SH	35mm 1,8° High Torque Hybrid Stepper motor	12
39SH	39mm 1,8° High Torque Hybrid Stepper motor	13
42SH	42mm 1,8° High Torque Hybrid Stepper motor	16
42SH M	42mm 0,9° High Torque Hybrid Stepper motor	20
57S	57mm 1,8° Standard hybrid Stepper motor	23
57SH	57mm 1,8° High Torque hybrid Stepper motor	27
57SH M	57mm 0,9° High Torque hybrid Stepper motor	31
60 SH	60mm 1,8° High Torque hybrid Stepper motor	34
63S10	63mm 1.8° FLAT Hybrid Stepper motor	35
86S	86mm 1,8° Low Inertia High Torque hybrid Stepper motor	36
86SH	86mm 1,8° High Torque hybrid Stepper motor	37
110SH	110mm 1,8° High Torque hybrid Stepper motor	42

3 Phase Stepper

423P	42mm 1,2° 3 Phase High Torque Hybrid Stepper motor	45
573P	57mm 1,2° 3 Phase High Torque hybrid Stepper motor	47

Brushless MOTOR

22BL	22mm Brushless Motor	52
28BL	28mm Brushless Motor	53
33BL	33mm Brushless Motor	54
36BL	36mm Brushless Motor	55
42BL	42mm Brushless Motor square	56
42BLH	42mm High torque Brushless Motor square	57
42RBL	42mm Brushless Motor round	58
45BLW	45mm FLAT Brushless Motor	59
57BL	57mm Brushless Motor	62
57HBL	57mm High torque Brushless Motor square	63
86BL	86mm Brushless Motor	64

Brushless MOTOR WITH INTEGRATED DRIVER

28BL38-IE	28mm Brushless Motor with integrated driver	65
28BL38-IE2	28mm Brushless Motor with integrated driver fixed speed	66
33BL38-IE	33mm Brushless Motor with integrated driver	67
42BL-IE	42mm Brushless Motor with integrated driver	68
42RBL-IE	42mm Brushless Motor with integrated driver	69
57BL-IE	57mm Brushless Motor with integrated driver	70

Special MOTOR CUSTOMIZATION	72
------------------------------------	----

Stepper MOTOR BASIC	74
----------------------------	----

Brushless MOTOR BASIC	80
------------------------------	----

Fulling MOTOR

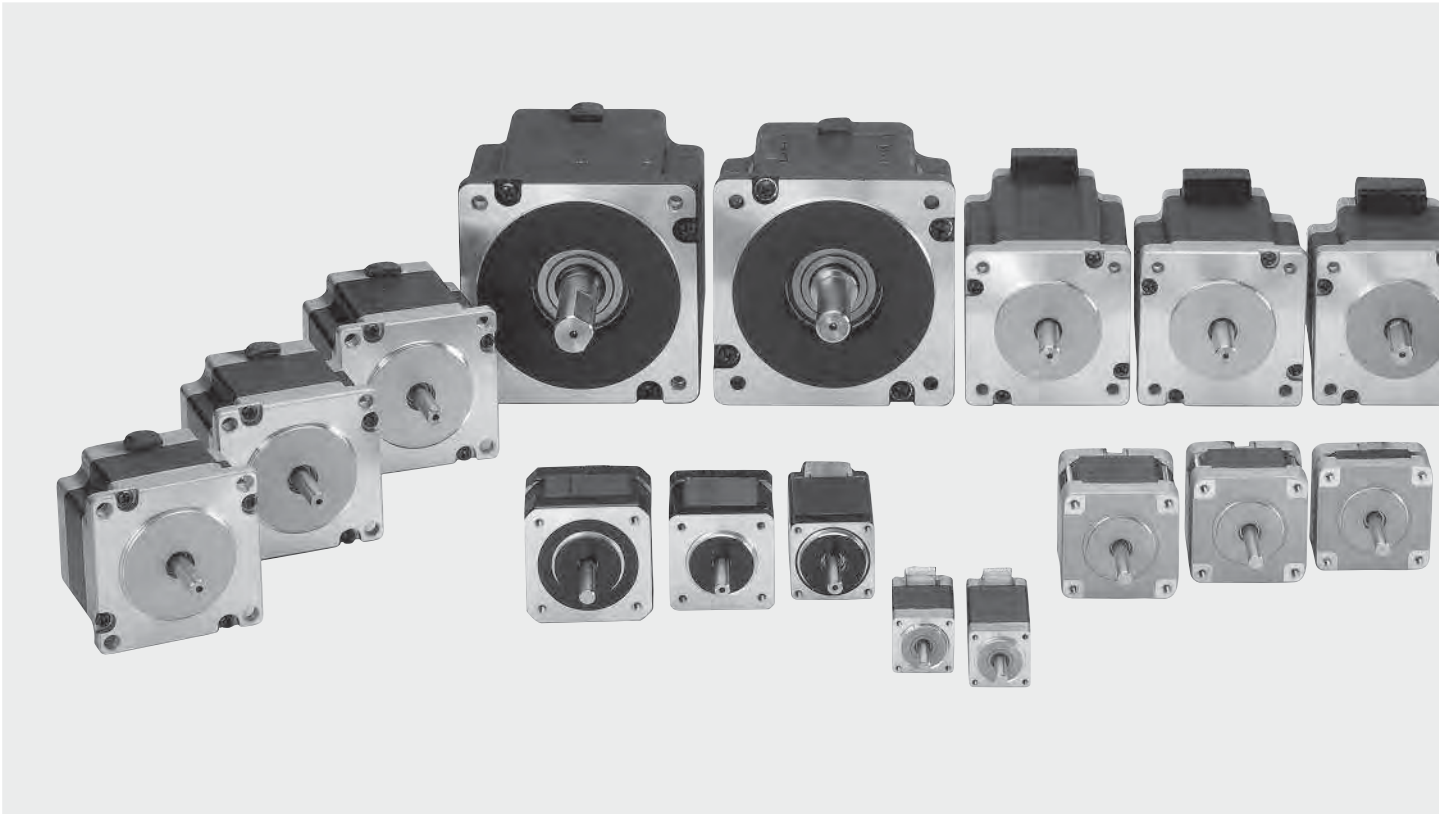

Production Final Test

- Insulation resistance: 500VDC, 100Mohm
- dielectric strength: 620VAC, 1 sec, 2mA
- Resistance/phase
- Inductance/phase
- Holding torque
- Detent torque
- Direction testing

Running Test

- Max. running frequency at no load
- Smooth running
- Noise and vibration

Appearance Testing

- Output shaft
- Lead wires
- Mounting dimension (flange - screw - D-cut - etc)

Quality Control Additional Test

- Frequency vs torque curve
- No load temperature rising



Stepper MOTOR

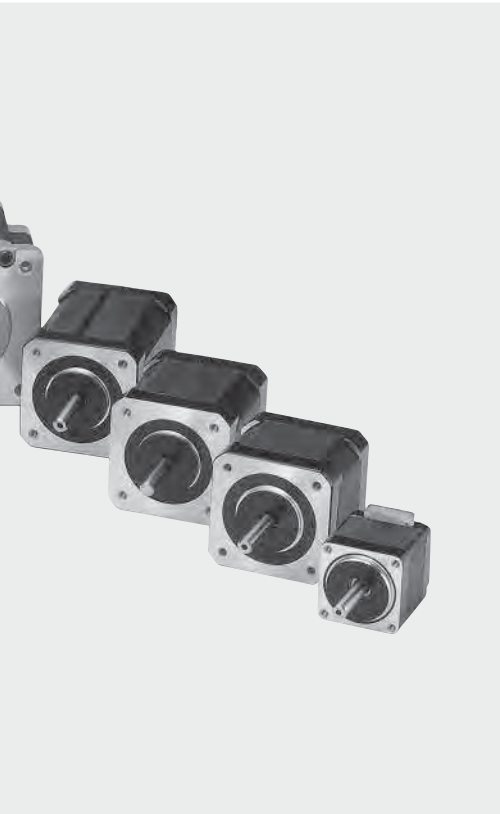

Codification number

42	Size in mm.
S	Motor type: S= standard stepper / SH= stepper high torque
33	Motor length in mm.
xxx	Winding code
x N°	Lead Wires
A	Shaft configuration: A= 1 shaft / B= 2 shaft
M	Null= 200 step/rev - M= 400 step/rev
xxxx	Exec: Number Special configuration

4 Leads
Bipolar connection

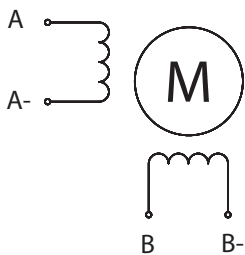

6 Leads
Unipolar connection

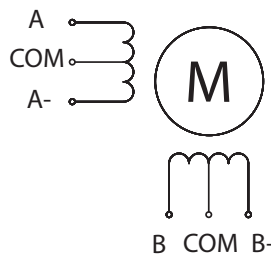

6 Leads
Series connection

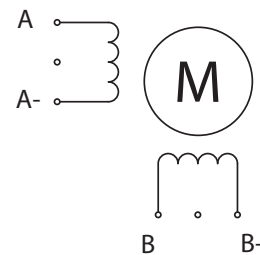

8 Leads
Unipolar connection

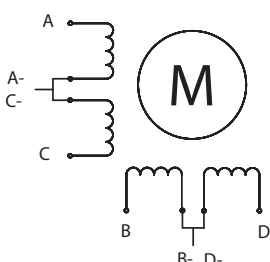

8 Leads
Serial connection

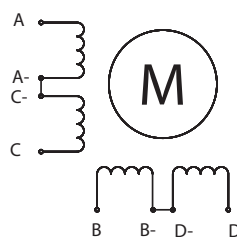

8 Leads
Parallel connection

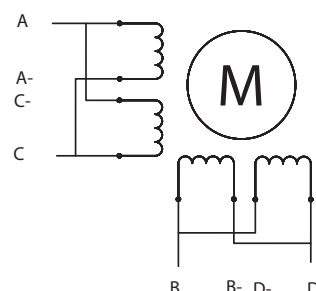

Stepper MOTOR

20SH High Torque Hybrid

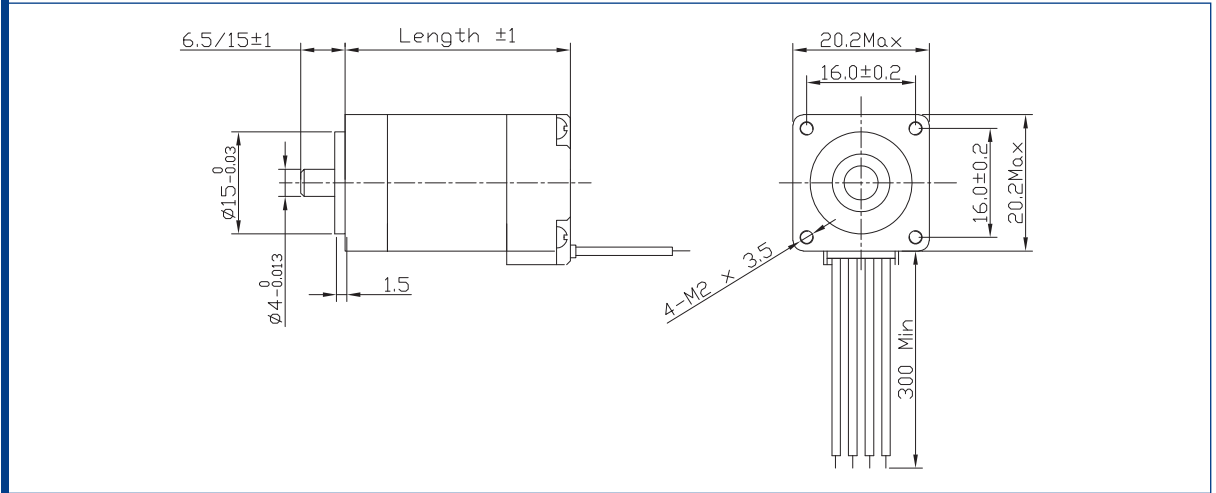

Specification

Model		20SH33-0604A	20SH42-0804A
1 RATED VOLTAGE	V	3,96	4,32
2 CURRENT/PHASE	A	0,6	0,8
3 RESISTANCE/PHASE	Ω	6,5	5,4
4 INDUCTANCE/PHASE	mH	1,7	1,5
5 HOLDING TORQUE	NM	0,0175	0,03
6 ROTOR INERTIA	g-CM ²	2	3,6
7 WEIGHT	KG	0,06	0,08
8 NUMBER OF LEADS	N°	4	4
9 LENGHT	MM	33	42

Characteristics

STEP ANGLE	1,8°
STEP ANGLE ACCURACY	$\pm 5\%$
INSULATION CLASS	B
AMBIENT TEMPERATURE	-20°C +50°C
TEMP. RISE	80°C MAX (RATED CURRENT, 2 PHASE ON)
INSULATION RESISTANCE	100 M OHM MIN. 500 VDC
DIELECTRIC STRENGTH	500 VAC FOR ONE MINUTE
SHAFT RADIAL PLAY	0,02 MAX (450 G LOAD)
SHAFT AXIAL PLAY	0,08 MAX. (450 G LOAD)
MAX RADIAL FORCE	28 N (20 MM FROM FRONT FLANGE)
MAX AXIAL FORCE	10 N

Speed vs. Torque Characteristics

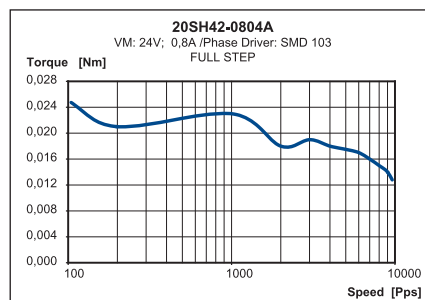
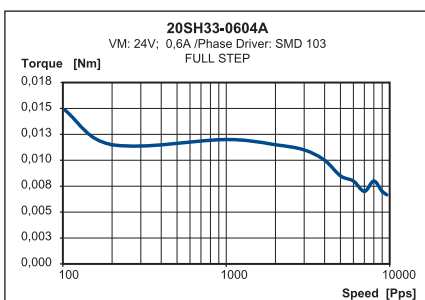

Connection

LEAD N°	COLOR	GAUGE	FUNCTION
1	BLACK	UL1430 AWG28	PHASE A
2	GREEN	UL1430 AWG28	PHASE A-
3	RED	UL1430 AWG28	PHASE B
4	BLUE	UL1430 AWG28	PHASE B-
UNIPOLAR MOTOR			
5	YELLOW	UL1430 AWG28	COM PHASE A
6	WHITE	UL1430 AWG28	COM PHASE B

Stepper MOTOR

25SH23-0704A

25SH23 High Torque Hybrid

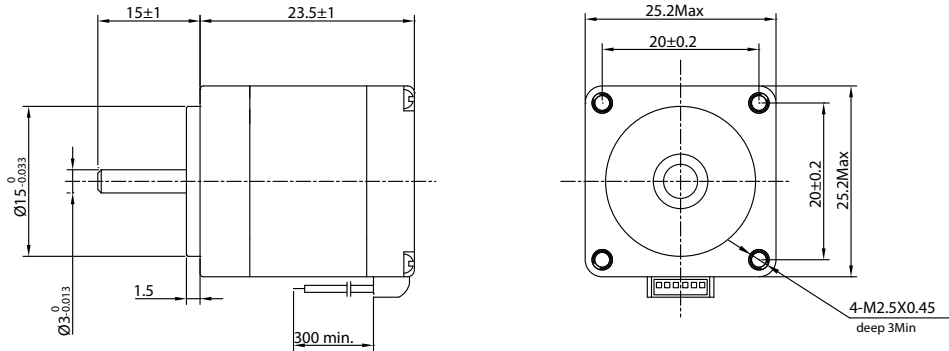

Characteristics

STEP ANGLE
1,8°

STEP ANGLE ACCURACY
± 5%

INSULATION CLASS
B

AMBIENT TEMPERATURE
-20°C +50°C

TEMP. RISE
80°C MAX (RATED CURRENT, 2 PHASE ON)

INSULATION RESISTANCE
100 M OHM MIN. 500 VDC

DIELECTRIC STRENGTH
500 VAC FOR ONE MINUTE

SHAFT RADIAL PLAY
0,02 MAX (450 G LOAD)

SHAFT AXIAL PLAY
0,08 MAX. (450 G LOAD)

MAX RADIAL FORCE
25 N (20 MM FROM FRONT FLANGE)

MAX AXIAL FORCE
10 N

Specification

Model	25SH23-0704A	
1 RATED VOLTAGE	V	3
2 CURRENT/PHASE	A	0.7
3 RESISTANCE/PHASE	Ω	4,3
4 INDUCTANCE/PHASE	mH	2,4
5 HOLDING TORQUE	Nm	0.33
6 ROTOR INERTIA	G-CM ²	2
7 WEIGHT	Kg	0.055
8 NUMBER OF LEADS	N°	4

Connection

PIN N°	COLOR	GAUGE	FUNCTION
1	BLACK	UL1061 AWG26	PHASE A
2	GREEN	UL1061 AWG26	PHASE A-
3	RED	UL1061 AWG26	PHASE B
4	BLUE	UL1061 AWG26	PHASE B-

Speed vs. Torque Characteristics

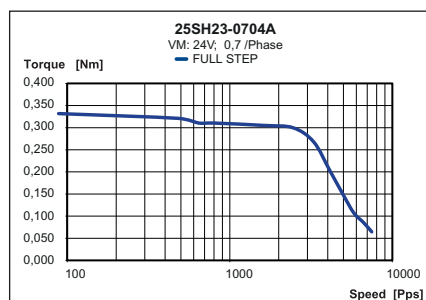

Stepper MOTOR

28SH32 High Torque Hybrid

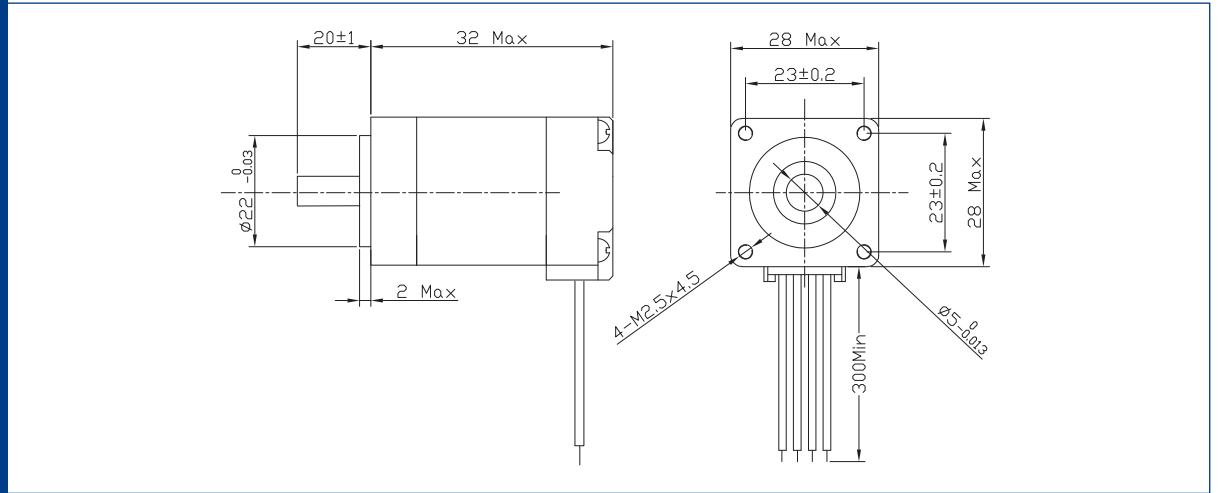

Specification

Model		28SH32-0956A	28SH32-0674A
1 RATED VOLTAGE	V	2,66	3,8
2 CURRENT/PHASE	A	0,95	0,67
3 RESISTANCE/PHASE	Ω	2,8	5,6
4 INDUCTANCE/PHASE	mH	0,8	3,4
5 HOLDING TORQUE	NM	0,043	0,06
6 ROTOR INERTIA	g-CM ²	9	9
7 WEIGHT	KG	0,11	0,11
8 NUMBER OF LEADS	N°	6	4

Characteristics

STEP ANGLE
1,8°

STEP ANGLE ACCURACY
± 5%

INSULATION CLASS
B

AMBIENT TEMPERATURE
-20°C +50°C

TEMP. RISE
80°C MAX (RATED CURRENT, 2 PHASE ON)

INSULATION RESISTANCE
100 M OHM MIN. 500 VDC

DIELECTRIC STRENGTH
500 VAC FOR ONE MINUTE

SHAFT RADIAL PLAY
0,02 MAX (450 G LOAD)

SHAFT AXIAL PLAY
0,08 MAX. (450 G LOAD)

MAX RADIAL FORCE
28 N (20 MM FROM FRONT FLANGE)

MAX AXIAL FORCE
10 N

Speed vs. Torque Characteristics

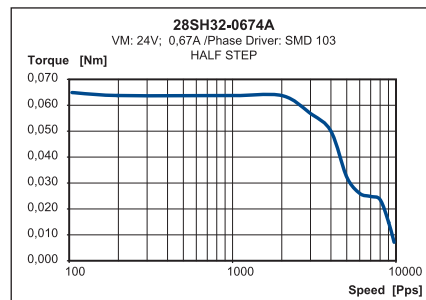
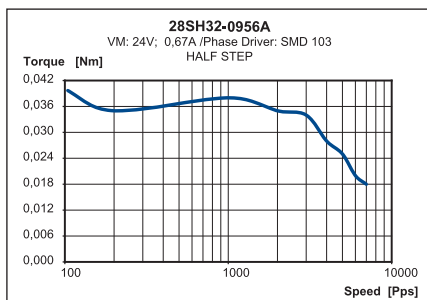

Connection

LEAD N°	COLOR	GAUGE	FUNCTION
1	BLACK	UL1430 AWG26	PHASE A
2	GREEN	UL1430 AWG26	PHASE A-
3	RED	UL1430 AWG26	PHASE B
4	BLUE	UL1430 AWG26	PHASE B-
UNIPOLAR MOTOR			
5	YELLOW	UL1430 AWG26	COM PHASE A
6	WHITE	UL1430 AWG26	COM PHASE B

Stepper MOTOR

28SH51 High Torque Hybrid

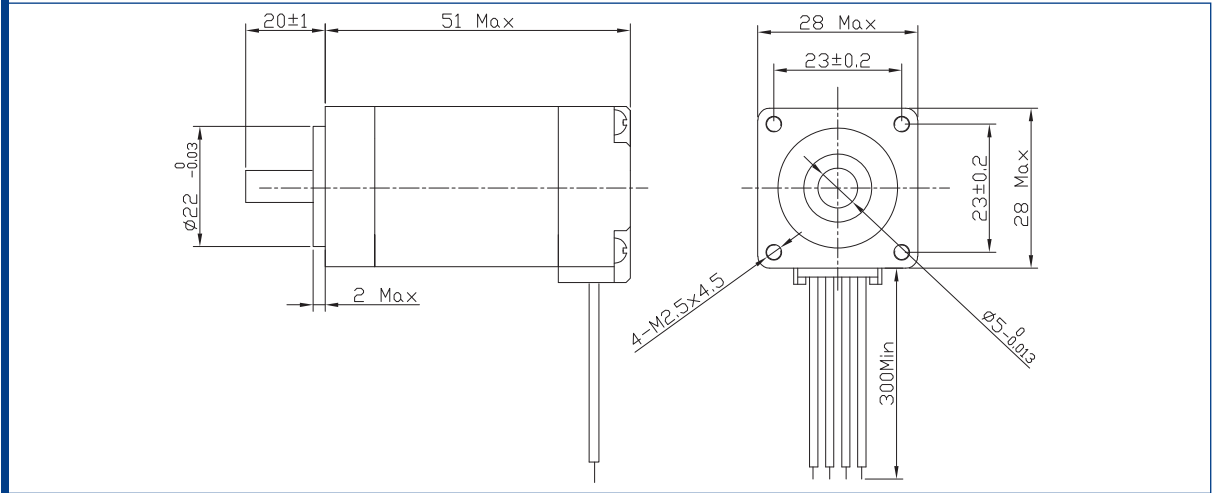

Specification

Model		28SH51-0956A	28SH51-0674A
1 RATED VOLTAGE	V	4,4	6,2
2 CURRENT/PHASE	A	0,95	0,67
3 RESISTANCE/PHASE	Ω	4,6	9,2
4 INDUCTANCE/PHASE	mH	1,8	7,2
5 HOLDING TORQUE	Nm	0,09	0,12
6 ROTOR INERTIA	g-cm ²	18	18
7 WEIGHT	Kg	0,2	0,2
8 NUMBER OF LEADS	N°	6	4

Characteristics

STEP ANGLE	1,8°
STEP ANGLE ACCURACY	± 5%
INSULATION CLASS	B
AMBIENT TEMPERATURE	-20°C +50°C
TEMP. RISE	80°C MAX (RATED CURRENT, 2 PHASE ON)
INSULATION RESISTANCE	100 M OHM MIN. 500 VDC
DIELECTRIC STRENGTH	500 VAC FOR ONE MINUTE
SHAFT RADIAL PLAY	0,02 MAX (450 G LOAD)
SHAFT AXIAL PLAY	0,08 MAX. (450 G LOAD)
MAX RADIAL FORCE	28 N (20 MM FROM FRONT FLANGE)
MAX AXIAL FORCE	10 N

Speed vs. Torque Characteristics

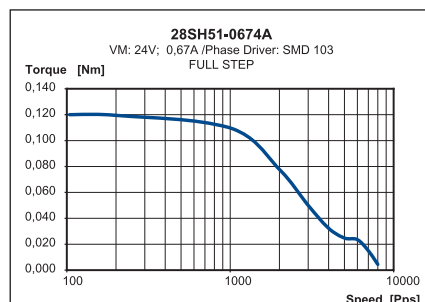
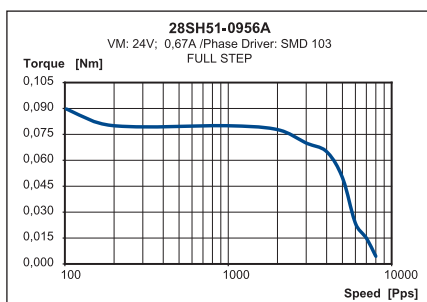

Connection

LEAD N°	COLOR	GAUGE	FUNCTION
1	BLACK	UL1430 AWG26	PHASE A
2	GREEN	UL1430 AWG26	PHASE A-
3	RED	UL1430 AWG26	PHASE B
4	BLUE	UL1430 AWG26	PHASE B-
UNIPOLAR MOTOR			
5	YELLOW	UL1430 AWG26	COM PHASE A
6	WHITE	UL1430 AWG26	COM PHASE B

Stepper MOTOR

28S10 Flat Hybrid Stepper

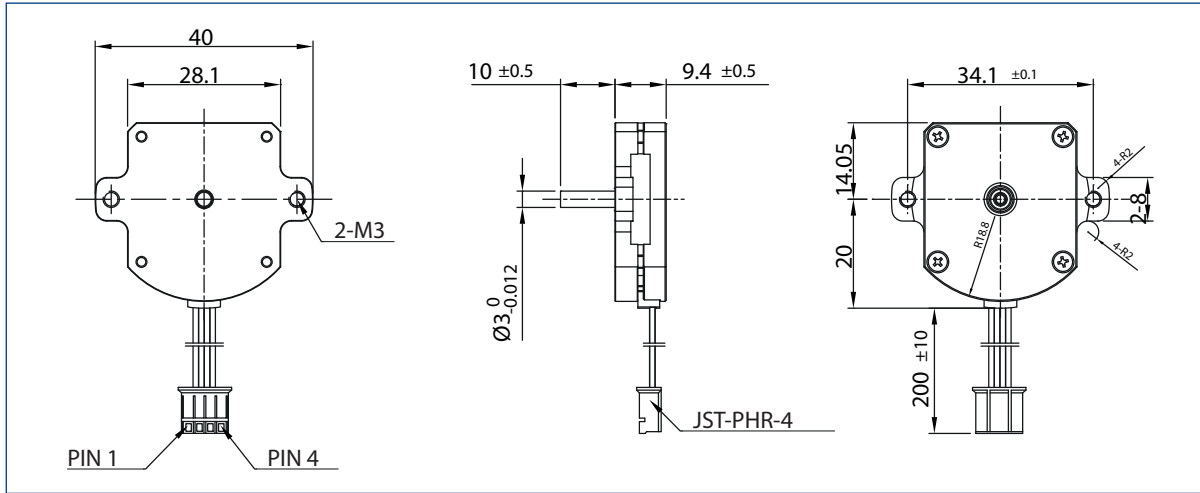

Characteristics

STEP ANGLE
1,8°

STEP ANGLE ACCURACY
± 5%

INSULATION CLASS
B

AMBIENT TEMPERATURE
-20°C +50°C

TEMP. RISE
80°C MAX (RATED CURRENT, 2 PHASE ON)

INSULATION RESISTANCE
100 M OHM MIN. 500 VDC

DIELECTRIC STRENGTH
500 VAC/50Hz/1 SEC/3MA

SHAFT RADIAL PLAY
0,06 MAX (450 G LOAD)

SHAFT AXIAL PLAY
0,04 MAX. (450 G LOAD)

MAX RADIAL FORCE
4.5 N (20 MM FROM FRONT FLANGE)

MAX AXIAL FORCE
4.5 N

Specification

Model	28S10-0504	
1 RATED VOLTAGE	V	1,85
2 CURRENT/PHASE	A	0,5
3 RESISTANCE/PHASE	Ω	3,7
4 INDUCTANCE/PHASE	mH	0,88
5 HOLDING TORQUE	Nm	0,098
6 ROTOR INERTIA	g-cm ²	1,7
7 WEIGHT	Kg	0,028
8 NUMBER OF LEADS	N°	4

Connection

LEAD N°	COLOR	GAUGE	FUNCTION
1	RED	UL1061 AWG26	PHASE A
2	BLUE	UL1061 AWG26	PHASE A-
3	ORANGE	UL1061 AWG26	PHASE B
4	YELLOW	UL1061 AWG26	PHASE B-

Stepper MOTOR

35SH High Torque Hybrid

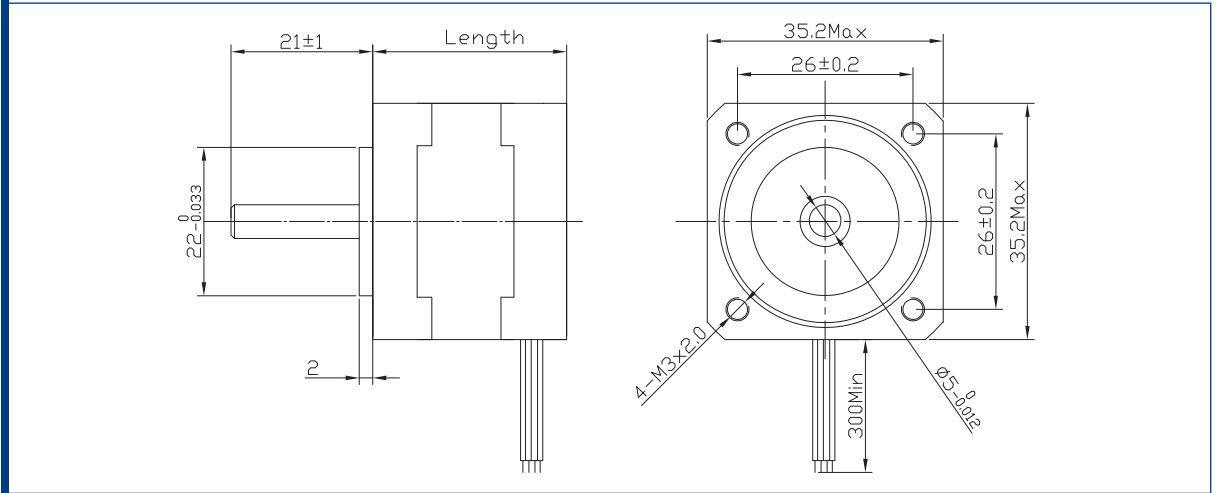

Specification

Model		35SH26-0284A	35SH28-0504A	35SH36-1004A
1 RATED VOLTAGE	V	7,4	10	2,7
2 CURRENT/PHASE	A	0,28	0,5	1
3 RESISTANCE/PHASE	Ω	26	20	2,7
4 INDUCTANCE/PHASE	mH	27	14	4,3
5 HOLDING TORQUE	NM	0,07	0,1	0,14
6 ROTOR INERTIA	g-cm ²	10	11	14
7 WEIGHT	KG	0,13	0,14	0,18
8 NUMBER OF LEADS	N°	4	4	4
9 LENGHT	MM	26	28	36

Speed vs. Torque Characteristics

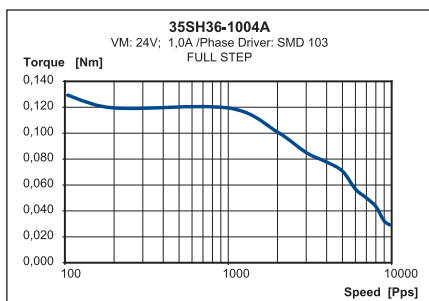
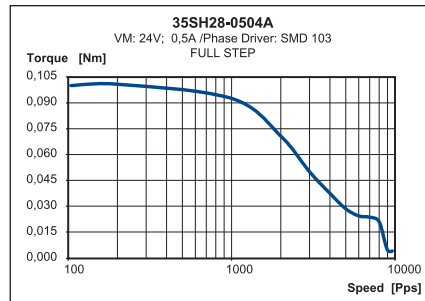
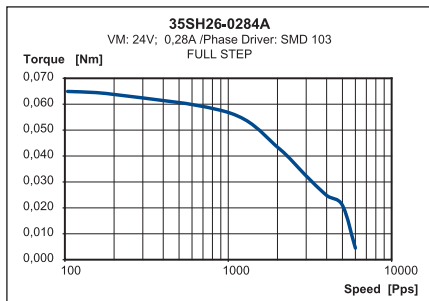

Characteristics

STEP ANGLE
1,8°

STEP ANGLE ACCURACY
± 5%

INSULATION CLASS
B

AMBIENT TEMPERATURE
-20°C +50°C

TEMP. RISE
80°C MAX (RATED CURRENT, 2 PHASE ON)

INSULATION RESISTANCE
100 M OHM MIN. 500 VDC

DIELECTRIC STRENGTH
500 VAC FOR ONE MINUTE

SHAFT RADIAL PLAY
0,02 MAX (450 G LOAD)

SHAFT AXIAL PLAY
0,08 MAX. (450 G LOAD)

MAX RADIAL FORCE
28 N (20 MM FROM FRONT FLANGE)

MAX AXIAL FORCE
10 N

Connection

LEAD N°	COLOR	GAUGE	FUNCTION
1	BLACK	UL1430 AWG26	PHASE A
2	GREEN	UL1430 AWG26	PHASE A-
3	RED	UL1430 AWG26	PHASE B
4	BLUE	UL1430 AWG26	PHASE B-
UNIPOLAR MOTOR			
5	YELLOW	UL1430 AWG26	COM PHASE A
6	WHITE	UL1430 AWG26	COM PHASE B

Stepper MOTOR

39SH20 High Torque Hybrid

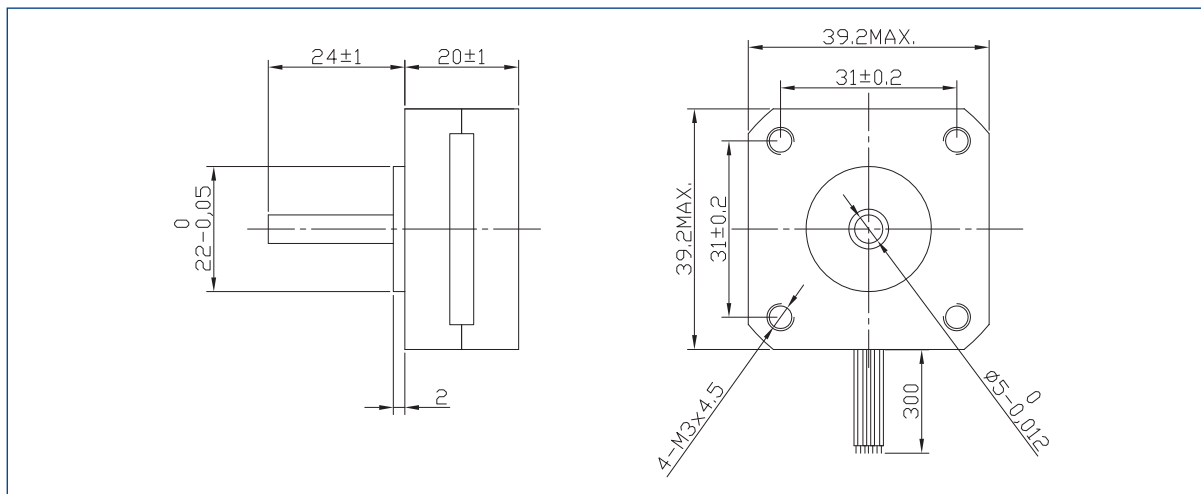

Characteristics

STEP ANGLE
1,8°

STEP ANGLE ACCURACY
± 5%

INSULATION CLASS
B

AMBIENT TEMPERATURE
-20°C +50°C

TEMP. RISE
80°C MAX (RATED CURRENT, 2 PHASE ON)

INSULATION RESISTANCE
100 M OHM MIN. 500 VDC

DIELECTRIC STRENGTH
500 VAC FOR ONE MINUTE

SHAFT RADIAL PLAY
0,02 MAX (450 G LOAD)

SHAFT AXIAL PLAY
0,08 MAX. (450 G LOAD)

MAX RADIAL FORCE
28 N (20 MM FROM FRONT FLANGE)

MAX AXIAL FORCE
10 N

Specification

Model		39SH20-0404A	39SH20-0506A
1 RATED VOLTAGE	V	2,64	6,5
2 CURRENT/PHASE	A	0,4	0,5
3 RESISTANCE/PHASE	Ω	6,6	13
4 INDUCTANCE/PHASE	mH	7,5	7,5
5 HOLDING TORQUE	Nm	0,065	0,08
6 ROTOR INERTIA	g-cm ²	11	11
7 WEIGHT	Kg	0,12	0,12
8 NUMBER OF LEADS	N°	4	6

Connection

LEAD N°	COLOR	GAUGE	FUNCTION
1	BLACK	UL1430 AWG26	PHASE A
2	GREEN	UL1430 AWG26	PHASE A-
3	RED	UL1430 AWG26	PHASE B
4	BLUE	UL1430 AWG26	PHASE B-
UNIPOLAR MOTOR			
5	YELLOW	UL1430 AWG26	COM PHASE A
6	WHITE	UL1430 AWG26	COM PHASE B

Speed vs. Torque Characteristics

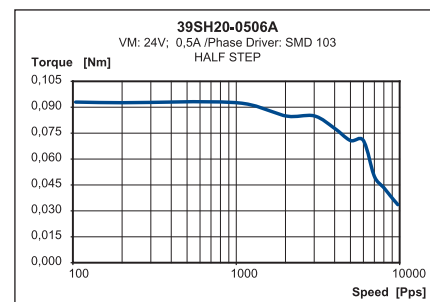
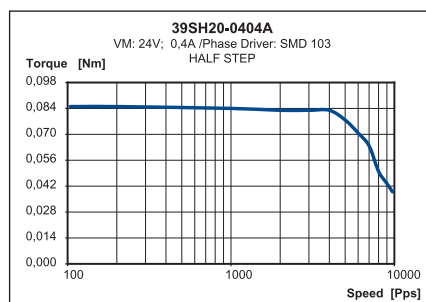

Stepper MOTOR

39SH34 High Torque Hybrid

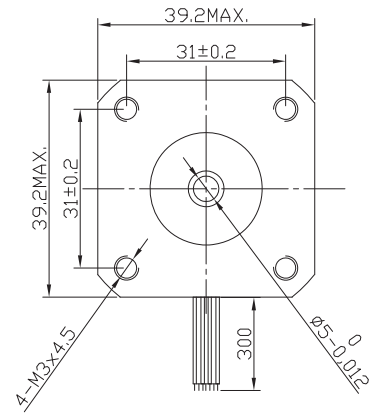
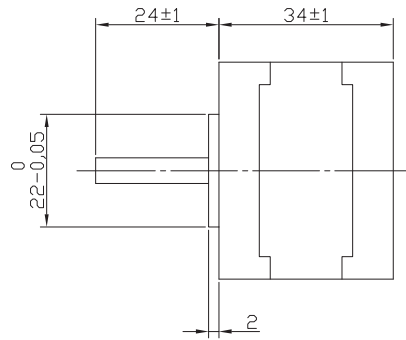

Specification

Model		39SH34-0306A	39SH34-0654A	39SH34-0404A	39SH34-0604A
1 RATED VOLTAGE	V	12	4,55	12	9
2 CURRENT/PHASE	A	0,3	0,65	0,4	0,6
3 RESISTANCE/PHASE	Ω	40	7	30	15
4 INDUCTANCE/PHASE	mH	20	9,3	32	16
5 HOLDING TORQUE	Nm	0,13	0,18	0,21	0,21
6 ROTOR INERTIA	g·cm ²	20	20	20	20
7 WEIGHT	KG	0,18	0,18	0,18	0,18
8 NUMBER OF LEADS	N°	6	4	4	4

Speed vs. Torque Characteristics

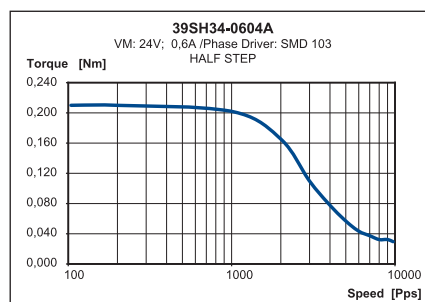
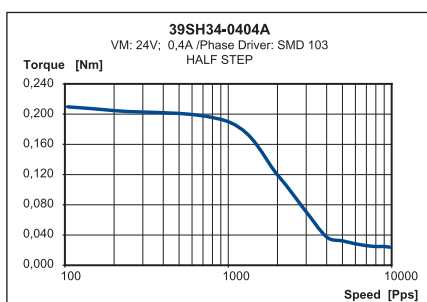
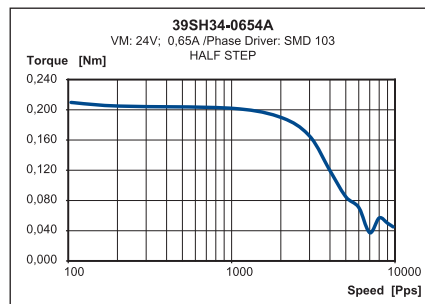
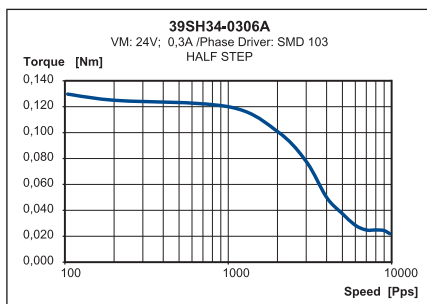

Characteristics

STEP ANGLE
1,8°

STEP ANGLE ACCURACY
± 5%

INSULATION CLASS
B

AMBIENT TEMPERATURE
-20°C +50°C

TEMP. RISE
80°C MAX (RATED CURRENT, 2 PHASE ON)

INSULATION RESISTANCE
100 M OHM MIN. 500 VDC

DIELECTRIC STRENGTH
500 VAC FOR ONE MINUTE

SHAFT RADIAL PLAY
0,02 MAX (450 G LOAD)

SHAFT AXIAL PLAY
0,08 MAX. (450 G LOAD)

MAX RADIAL FORCE
28 N (20 MM FROM FRONT FLANGE)

MAX AXIAL FORCE
10 N

Connection

LEAD N°	COLOR	GAUGE	FUNCTION
1	BLACK	UL1430 AWG26	PHASE A
2	GREEN	UL1430 AWG26	PHASE A-
3	RED	UL1430 AWG26	PHASE B
4	BLUE	UL1430 AWG26	PHASE B-
UNIPOLAR MOTOR			
5	YELLOW	UL1430 AWG26	COM PHASE A
6	WHITE	UL1430 AWG26	COM PHASE B

Stepper MOTOR

39SH38 High Torque Hybrid

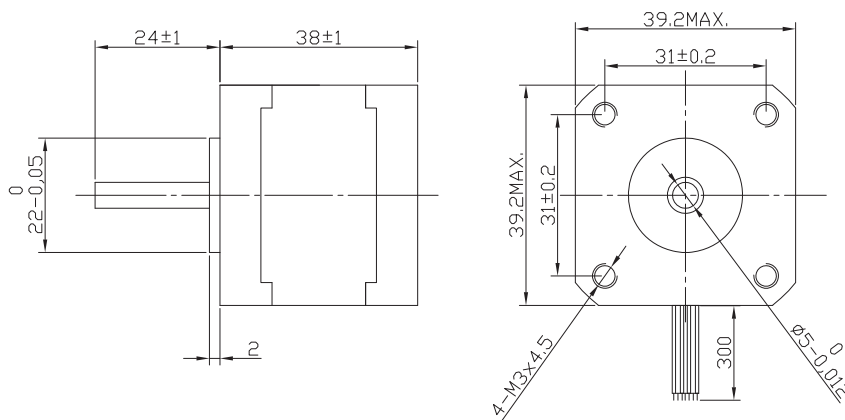

Characteristics

STEP ANGLE
1,8°

STEP ANGLE ACCURACY
± 5%

INSULATION CLASS
B

AMBIENT TEMPERATURE
-20°C +50°C

TEMP. RISE
80°C MAX (RATED CURRENT, 2 PHASE ON)

INSULATION RESISTANCE
100 M OHM MIN. 500 VDC

DIELECTRIC STRENGTH
500 VAC FOR ONE MINUTE

SHAFT RADIAL PLAY
0,02 MAX (450 G LOAD)

SHAFT AXIAL PLAY
0,08 MAX. (450 G LOAD)

MAX RADIAL FORCE
28 N (20 MM FROM FRONT FLANGE)

MAX AXIAL FORCE
10 N

Specification

Model		39SH38-0806A	39SH38-0304A	39SH38-0504A
1 RATED VOLTAGE	V	6	12	12
2 CURRENT/PHASE	A	0,8	0,3	0,5
3 RESISTANCE/PHASE	Ω	7,5	40	24
4 INDUCTANCE/PHASE	mH	6	100	45
5 HOLDING TORQUE	NM	0,2	0,28	0,29
6 ROTOR INERTIA	G-CM ²	24	24	24
7 WEIGHT	KG	0,2	0,2	0,2
8 NUMBER OF LEADS	N°	6	4	4

Speed vs. Torque Characteristics

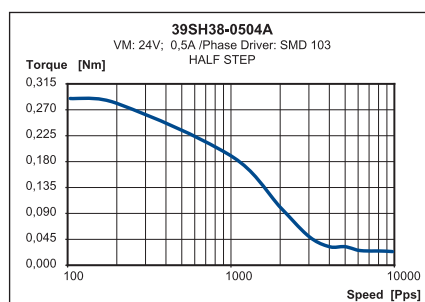
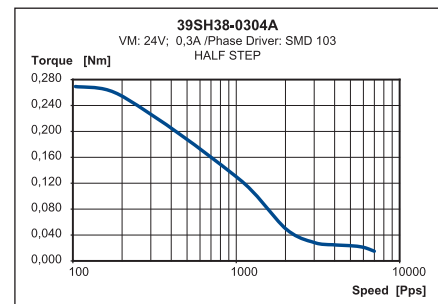
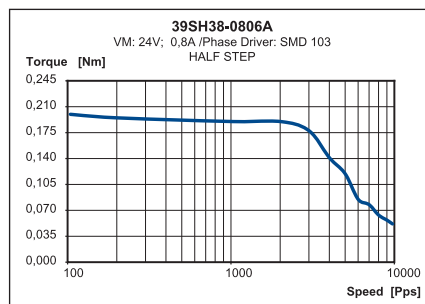

Connection

LEAD N°	COLOR	GAUGE	FUNCTION
1	BLACK	UL1430 AWG26	PHASE A
2	GREEN	UL1430 AWG26	PHASE A-
3	RED	UL1430 AWG26	PHASE B
4	BLUE	UL1430 AWG26	PHASE B-
UNIPOLAR MOTOR			
5	YELLOW	UL1430 AWG26	COM PHASE A
6	WHITE	UL1430 AWG26	COM PHASE B

Stepper MOTOR

42SH33 High Torque Hybrid

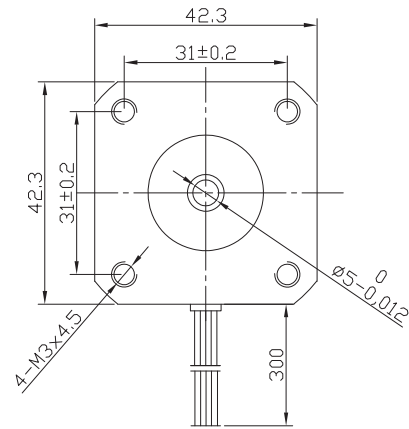
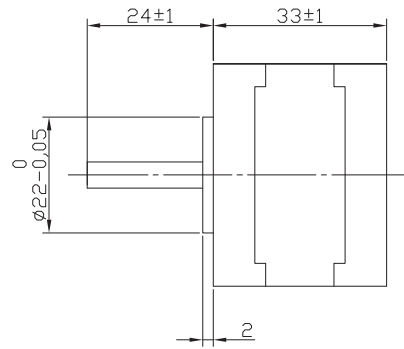

Specification

Model		42SH33-1A	42SH33-2A	42SH33-3A	42SH33-4A
1 RATED VOLTAGE	V	4	9,6	12	2,8
2 CURRENT/PHASE	A	0,95	0,4	0,31	1,33
3 RESISTANCE/PHASE	Ω	4,2	24	38,5	2,1
4 INDUCTANCE/PHASE	mH	2,5	15	21	2,5
5 HOLDING TORQUE	NM	0,158	0,158	0,158	0,22
6 ROTOR INERTIA	g-cm ²	35	35	35	35
7 WEIGHT	KG	0,22	0,22	0,22	0,22
8 NUMBER OF LEADS	N°	6	6	6	4

Speed vs. Torque Characteristics

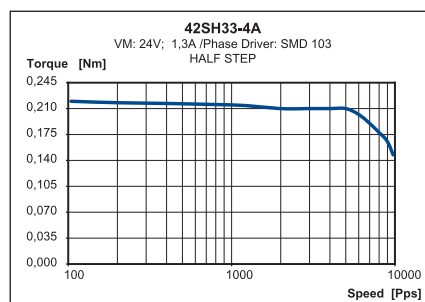
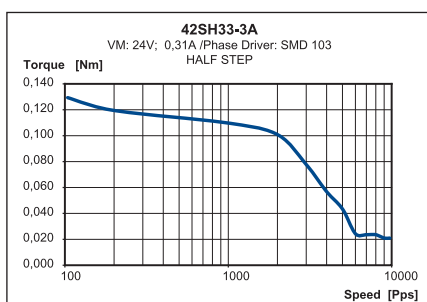
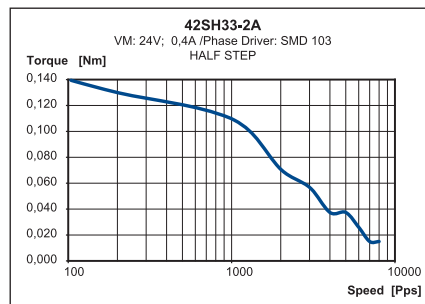
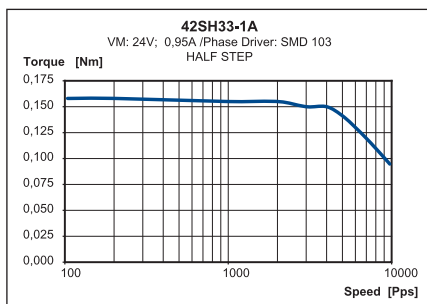

Characteristics

STEP ANGLE
1,8°

STEP ANGLE ACCURACY
± 5%

INSULATION CLASS
B

AMBIENT TEMPERATURE
-20°C +50°C

TEMP. RISE
80°C MAX (RATED CURRENT, 2 PHASE ON)

INSULATION RESISTANCE
100 M OHM MIN. 500 VDC

DIELECTRIC STRENGTH
500 VAC FOR ONE MINUTE

SHAFT RADIAL PLAY
0,02 MAX (450 G LOAD)

SHAFT AXIAL PLAY
0,08 MAX. (450 G LOAD)

MAX RADIAL FORCE
28 N (20 MM FROM FRONT FLANGE)

MAX AXIAL FORCE
10 N

Connection

LEAD N°	COLOR	GAUGE	FUNCTION
1	BLACK	UL1430 AWG26	PHASE A
2	GREEN	UL1430 AWG26	PHASE A-
3	RED	UL1430 AWG26	PHASE B
4	BLUE	UL1430 AWG26	PHASE B-
UNIPOLAR MOTOR			
5	YELLOW	UL1430 AWG26	COM PHASE A
6	WHITE	UL1430 AWG26	COM PHASE B

Stepper MOTOR

42SH38 High Torque Hybrid

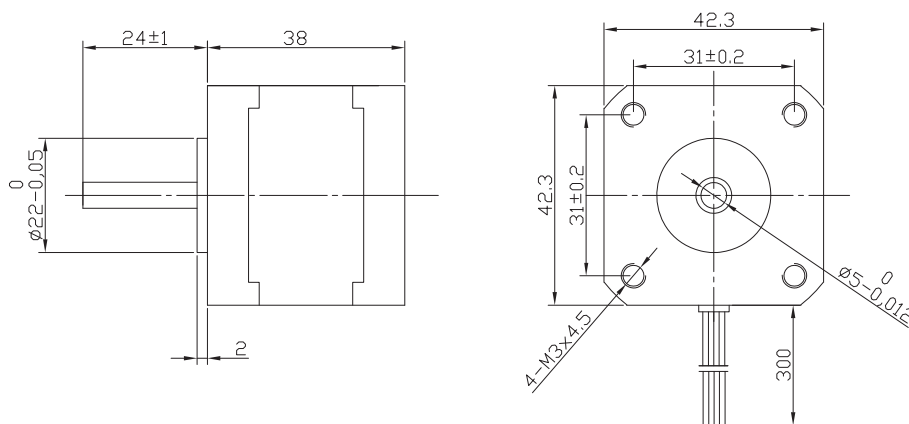

Characteristics

STEP ANGLE
1,8°

STEP ANGLE ACCURACY
± 5%

INSULATION CLASS
B

AMBIENT TEMPERATURE
-20°C +50°C

TEMP. RISE
80°C MAX (RATED CURRENT, 2 PHASE ON)

INSULATION RESISTANCE
100 M OHM MIN. 500 VDC

DIELECTRIC STRENGTH
500 VAC FOR ONE MINUTE

SHAFT RADIAL PLAY
0,02 MAX (450 G LOAD)

SHAFT AXIAL PLAY
0,08 MAX. (450 G LOAD)

MAX RADIAL FORCE
28 N (20 MM FROM FRONT FLANGE)

MAX AXIAL FORCE
10 N

Specification

Model		42SH38-1A	42SH38-2A	42SH38-3A	42SH38-4A	
1	RATED VOLTAGE	V	4	6	12	2,8
2	CURRENT/PHASE	A	1,2	0,8	0,4	1,68
3	RESISTANCE/PHASE	Ω	3,3	7,5	30	1,65
4	INDUCTANCE/PHASE	mH	3,4	6,7	30	3,2
5	HOLDING TORQUE	NM	0,259	0,259	0,259	0,36
6	ROTOR INERTIA	G-CM ²	54	54	54	54
7	WEIGHT	KG	0,28	0,28	0,28	0,28
8	NUMBER OF LEADS	N°	6	6	6	4

Speed vs. Torque Characteristics

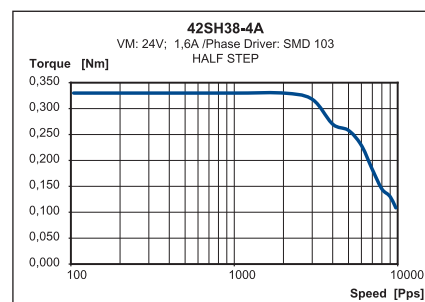
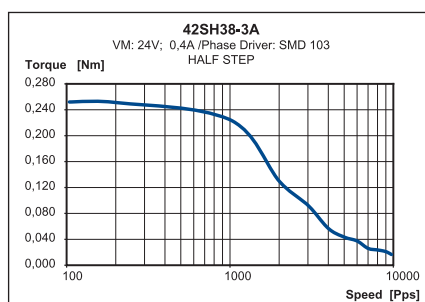
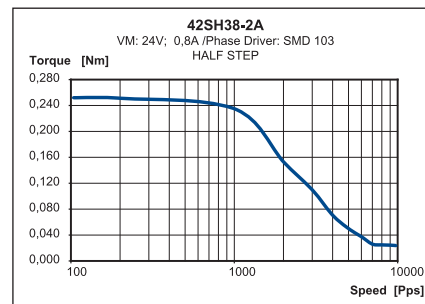
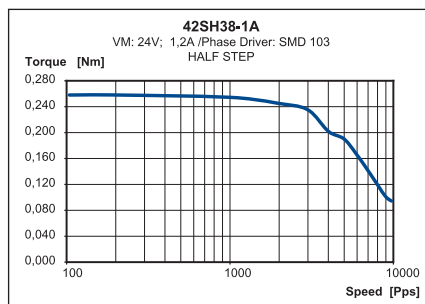

Connection

LEAD N°	COLOR	GAUGE	FUNCTION
1	BLACK	UL1430 AWG26	PHASE A
2	GREEN	UL1430 AWG26	PHASE A-
3	RED	UL1430 AWG26	PHASE B
4	BLUE	UL1430 AWG26	PHASE B-
UNIPOLAR MOTOR			
5	YELLOW	UL1430 AWG26	COM PHASE A
6	WHITE	UL1430 AWG26	COM PHASE B

Stepper MOTOR

42SH47 High Torque Hybrid

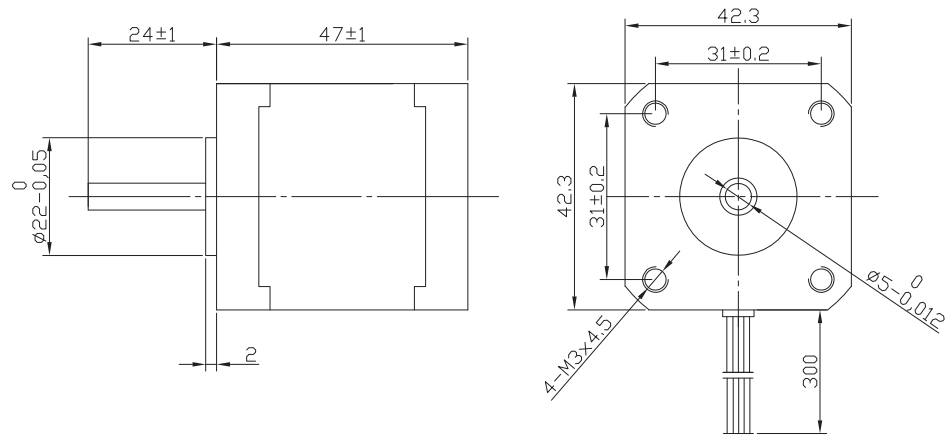

Specification

Model		42SH47-1A	42SH47-2A	42SH47-3A	42SH47-4A
1 RATED VOLTAGE	V	4	6	12	2,8
2 CURRENT/PHASE	A	1,2	0,8	0,4	1,68
3 RESISTANCE/PHASE	Ω	3,3	7,5	30	1,65
4 INDUCTANCE/PHASE	mH	2,8	6,3	25	2,8
5 HOLDING TORQUE	Nm	0,317	0,317	0,317	0,44
6 ROTOR INERTIA	g-cm ²	68	68	68	68
7 WEIGHT	KG	0,35	0,35	0,35	0,35
8 NUMBER OF LEADS	N°	6	6	6	4

Speed vs. Torque Characteristics

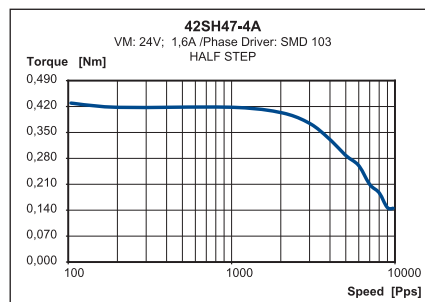
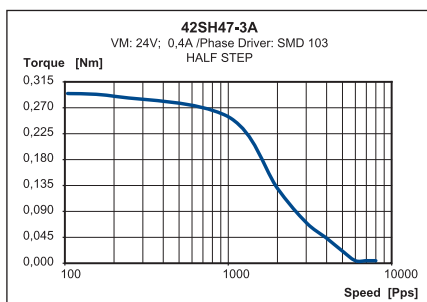
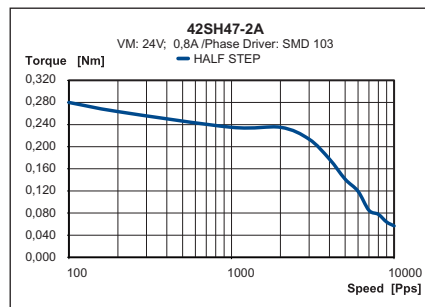
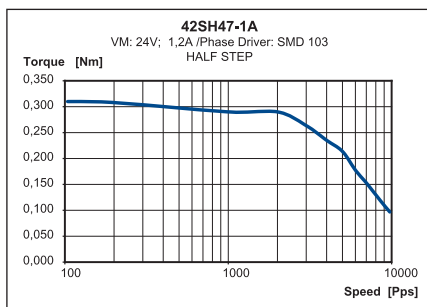

Characteristics

STEP ANGLE
1,8°

STEP ANGLE ACCURACY
± 5%

INSULATION CLASS
B

AMBIENT TEMPERATURE
-20°C +50°C

TEMP. RISE
80°C MAX (RATED CURRENT, 2 PHASE ON)

INSULATION RESISTANCE
100 M OHM MIN. 500 VDC

DIELECTRIC STRENGTH
500 VAC FOR ONE MINUTE

SHAFT RADIAL PLAY
0,02 MAX (450 G LOAD)

SHAFT AXIAL PLAY
0,08 MAX. (450 G LOAD)

MAX RADIAL FORCE
28 N (20 MM FROM FRONT FLANGE)

MAX AXIAL FORCE
10 N

Connection

LEAD N°	COLOR	GAUGE	FUNCTION
1	BLACK	UL1430 AWG26	PHASE A
2	GREEN	UL1430 AWG26	PHASE A-
3	RED	UL1430 AWG26	PHASE B
4	BLUE	UL1430 AWG26	PHASE B-
UNIPOLAR MOTOR			
5	YELLOW	UL1430 AWG26	COM PHASE A
6	WHITE	UL1430 AWG26	COM PHASE B

Stepper MOTOR

42SH60 High Torque Hybrid

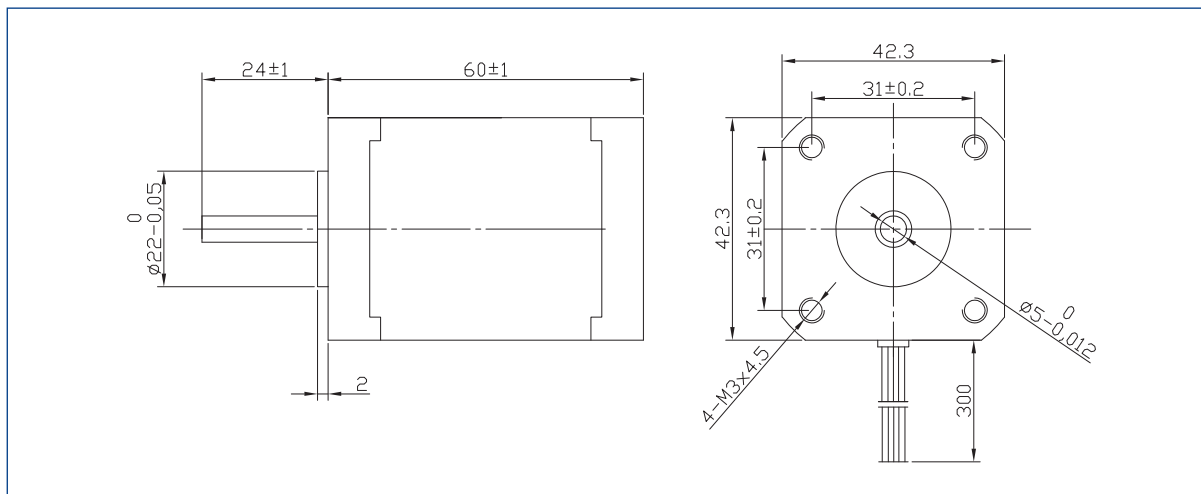

Characteristics

STEP ANGLE
1,8°

STEP ANGLE ACCURACY
± 5%

INSULATION CLASS
B

AMBIENT TEMPERATURE
-20°C +50°C

TEMP. RISE
80°C MAX (RATED CURRENT, 2 PHASE ON)

INSULATION RESISTANCE
100 M OHM MIN. 500 VDC

DIELECTRIC STRENGTH
500 VAC FOR ONE MINUTE

SHAFT RADIAL PLAY
0,02 MAX (450 G LOAD)

SHAFT AXIAL PLAY
0,08 MAX. (450 G LOAD)

MAX RADIAL FORCE
28 N (20 MM FROM FRONT FLANGE)

MAX AXIAL FORCE
10 N

Specification

Model		42SH60-1206A	42SH60-0854A
1 RATED VOLTAGE	V	7,2	10,2
2 CURRENT/PHASE	A	1,2	0,85
3 RESISTANCE/PHASE	Ω	6	12
4 INDUCTANCE/PHASE	mH	7	29
5 HOLDING TORQUE	Nm	0,65	0,9
6 ROTOR INERTIA	g-cm ²	102	102
7 WEIGHT	Kg	0,5	0,5
8 NUMBER OF LEADS	N°	6	4

Connection

LEAD N°	COLOR	GAUGE	FUNCTION
1	BLACK	UL1430 AWG26	PHASE A
2	GREEN	UL1430 AWG26	PHASE A-
3	RED	UL1430 AWG26	PHASE B
4	BLUE	UL1430 AWG26	PHASE B-
UNIPOLAR MOTOR			
5	YELLOW	UL1430 AWG26	COM PHASE A
6	WHITE	UL1430 AWG26	COM PHASE B

Speed vs. Torque Characteristics

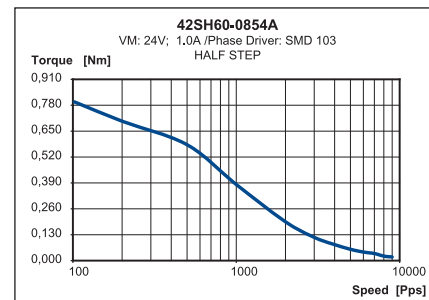
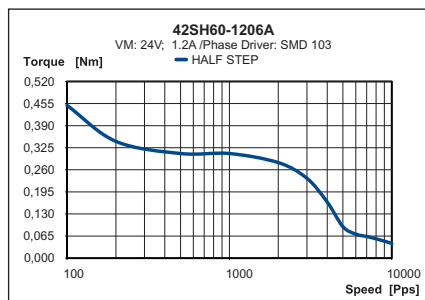

Stepper MOTOR

42SH33-M High Torque Hybrid

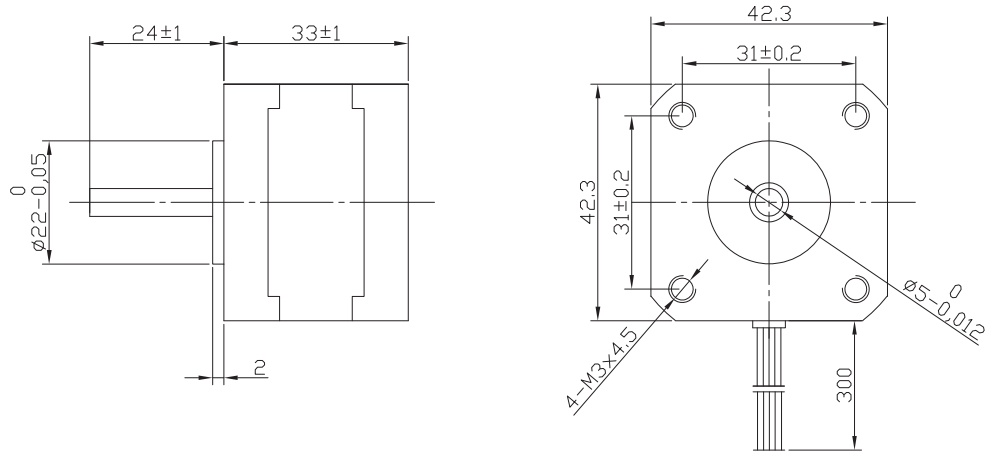

Specification

Model		42SH33-1AM	42SH33-2AM	42SH33-3AM	42SH33-4AM
1 RATED VOLTAGE	V	4	6	12	2,8
2 CURRENT/PHASE	A	0,95	0,6	0,31	1,33
3 RESISTANCE/PHASE	Ω	4,2	10	38,5	2,1
4 INDUCTANCE/PHASE	mH	4	9,5	33	4,2
5 HOLDING TORQUE	Nm	0,158	0,158	0,158	0,22
6 ROTOR INERTIA	g-cm ²	35	35	35	35
7 WEIGHT	Kg	0,22	0,22	0,22	0,22
8 NUMBER OF LEADS	N°	6	6	6	4

Speed vs. Torque Characteristics

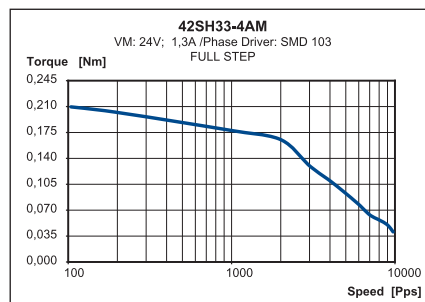
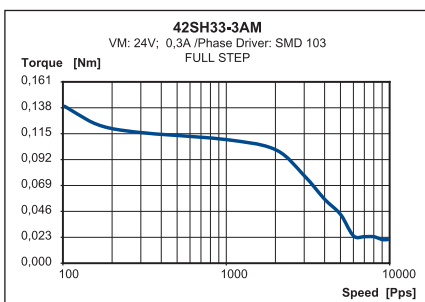
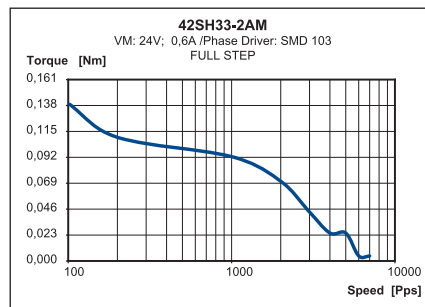
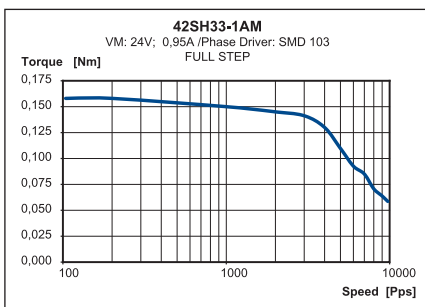

Characteristics

- STEP ANGLE
0,9°
- STEP ANGLE ACCURACY
± 5%
- INSULATION CLASS
B
- AMBIENT TEMPERATURE
-20°C +50°C
- TEMP. RISE
80°C MAX (RATED CURRENT, 2 PHASE ON)
- INSULATION RESISTANCE
100 M OHM MIN. 500 VDC
- DIELECTRIC STRENGTH
500 VAC FOR ONE MINUTE
- SHAFT RADIAL PLAY
0,02 MAX (450 G LOAD)
- SHAFT AXIAL PLAY
0,08 MAX. (450 G LOAD)
- MAX RADIAL FORCE
28 N (20 MM FROM FRONT FLANGE)
- MAX AXIAL FORCE
10 N

Connection

LEAD N°	COLOR	GAUGE	FUNCTION
1	BLACK	UL1430 AWG26	PHASE A
2	GREEN	UL1430 AWG26	PHASE A-
3	RED	UL1430 AWG26	PHASE B
4	BLUE	UL1430 AWG26	PHASE B-
UNIPOLAR MOTOR			
5	YELLOW	UL1430 AWG26	COM PHASE A
6	WHITE	UL1430 AWG26	COM PHASE B

Stepper MOTOR

42SH38-M High Torque Hybrid

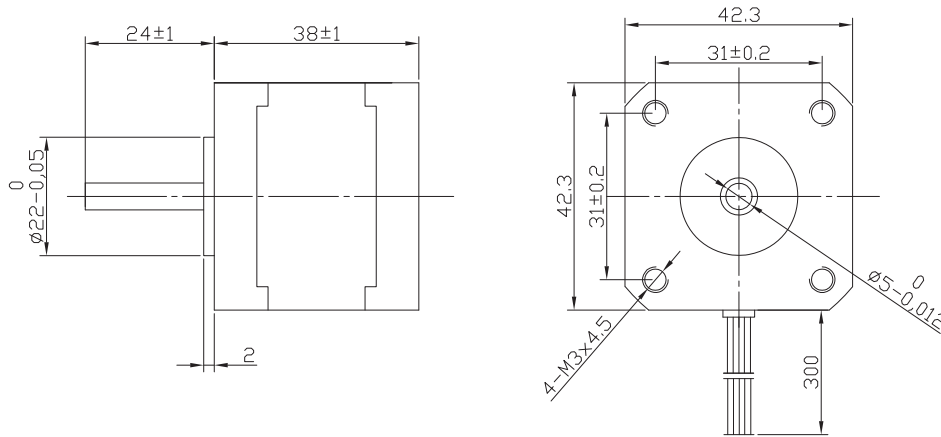

Characteristics

STEP ANGLE
0,9°

STEP ANGLE ACCURACY
± 5%

INSULATION CLASS
B

AMBIENT TEMPERATURE
-20°C +50°C

TEMP. RISE
80°C MAX (RATED CURRENT, 2 PHASE ON)

INSULATION RESISTANCE
100 M OHM MIN. 500 VDC

DIELECTRIC STRENGTH
500 VAC FOR ONE MINUTE

SHAFT RADIAL PLAY
0,02 MAX (450 G LOAD)

SHAFT AXIAL PLAY
0,08 MAX. (450 G LOAD)

MAX RADIAL FORCE
28 N (20 MM FROM FRONT FLANGE)

MAX AXIAL FORCE
10 N

Specification

Model		42SH38-1AM	42SH38-2AM	42SH38-3AM	42SH38-4AM
1 RATED VOLTAGE	V	4	6	12	2,8
2 CURRENT/PHASE	A	1,2	0,8	0,4	1,68
3 RESISTANCE/PHASE	Ω	3,3	7,5	30	1,65
4 INDUCTANCE/PHASE	mH	3,4	9,6	30	3,2
5 HOLDING TORQUE	Nm	0,259	0,259	0,259	0,36
6 ROTOR INERTIA	G-CM ²	54	54	54	54
7 WEIGHT	Kg	0,28	0,28	0,28	0,28
8 NUMBER OF LEADS	N°	6	6	6	4

Speed vs. Torque Characteristics

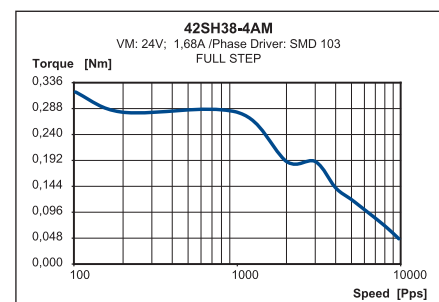
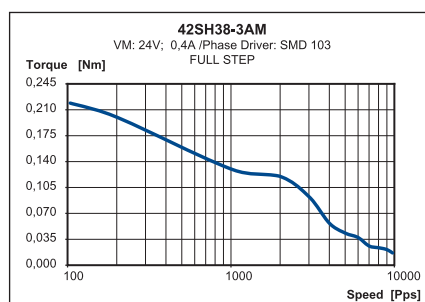
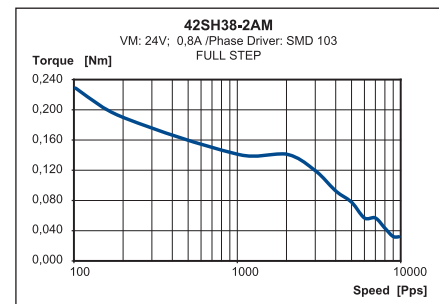
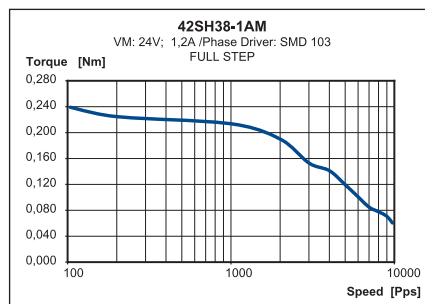

Connection

LEAD N°	COLOR	GAUGE	FUNCTION
1	BLACK	UL1430 AWG26	PHASE A
2	GREEN	UL1430 AWG26	PHASE A-
3	RED	UL1430 AWG26	PHASE B
4	BLUE	UL1430 AWG26	PHASE B-
UNIPOLAR MOTOR			
5	YELLOW	UL1430 AWG26	COM PHASE A
6	WHITE	UL1430 AWG26	COM PHASE B

Stepper MOTOR

42SH47-M High Torque Hybrid

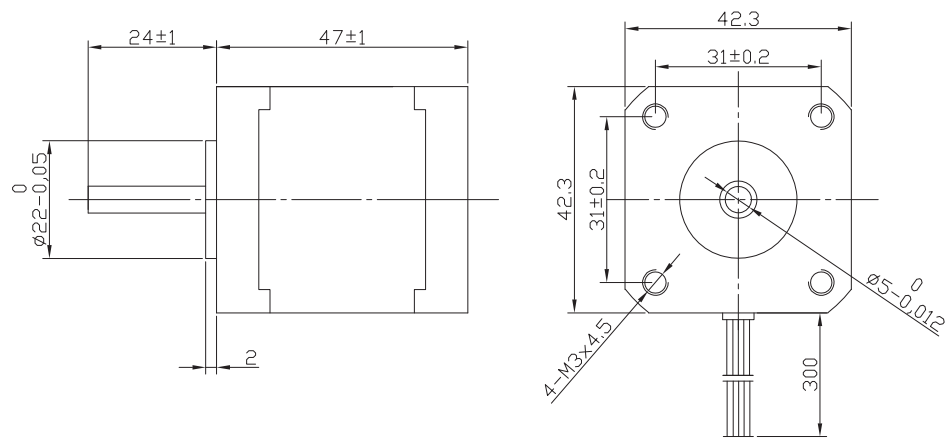

Specification

Model		42SH47-1AM	42SH47-2AM	42SH47-3AM	42SH47-4AM
1 RATED VOLTAGE	V	4	6	12	2,8
2 CURRENT/PHASE	A	1,2	0,8	0,4	1,68
3 RESISTANCE/PHASE	Ω	3,3	7,5	30	1,65
4 INDUCTANCE/PHASE	mH	4	10	38	4,1
5 HOLDING TORQUE	Nm	0,317	0,317	0,317	0,44
6 ROTOR INERTIA	g-cm ²	68	68	68	68
7 WEIGHT	Kg	0,35	0,35	0,35	0,35
8 NUMBER OF LEADS	N°	6	6	6	4

Speed vs. Torque Characteristics

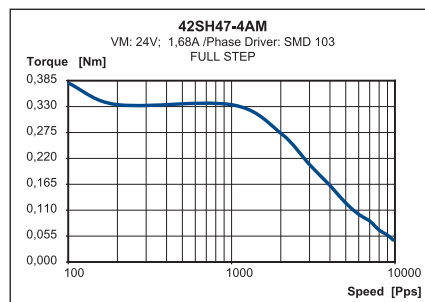
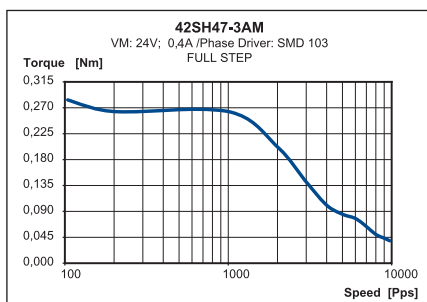
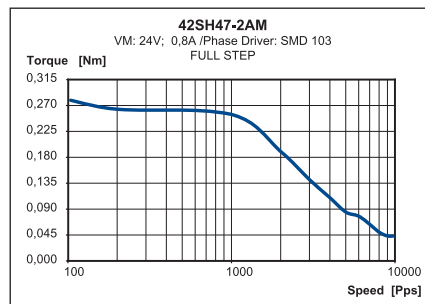
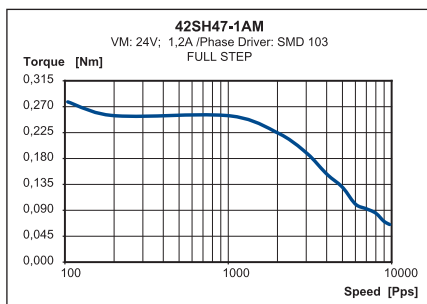

Characteristics

STEP ANGLE
0,9°

STEP ANGLE ACCURACY
± 5%

INSULATION CLASS
B

AMBIENT TEMPERATURE
-20°C +50°C

TEMP. RISE
80°C MAX (RATED CURRENT, 2 PHASE ON)

INSULATION RESISTANCE
100 M OHM MIN. 500 VDC

DIELECTRIC STRENGTH
500 VAC FOR ONE MINUTE

SHAFT RADIAL PLAY
0,02 MAX (450 G LOAD)

SHAFT AXIAL PLAY
0,08 MAX. (450 G LOAD)

MAX RADIAL FORCE
28 N (20 MM FROM FRONT FLANGE)

MAX AXIAL FORCE
10 N

Connection

LEAD N°	COLOR	GAUGE	FUNCTION
1	BLACK	UL1430 AWG26	PHASE A
2	GREEN	UL1430 AWG26	PHASE A-
3	RED	UL1430 AWG26	PHASE B
4	BLUE	UL1430 AWG26	PHASE B-
UNIPOLAR MOTOR			
5	YELLOW	UL1430 AWG26	COM PHASE A
6	WHITE	UL1430 AWG26	COM PHASE B

Stepper MOTOR

57S41 Hybrid

57S41 Hybrid

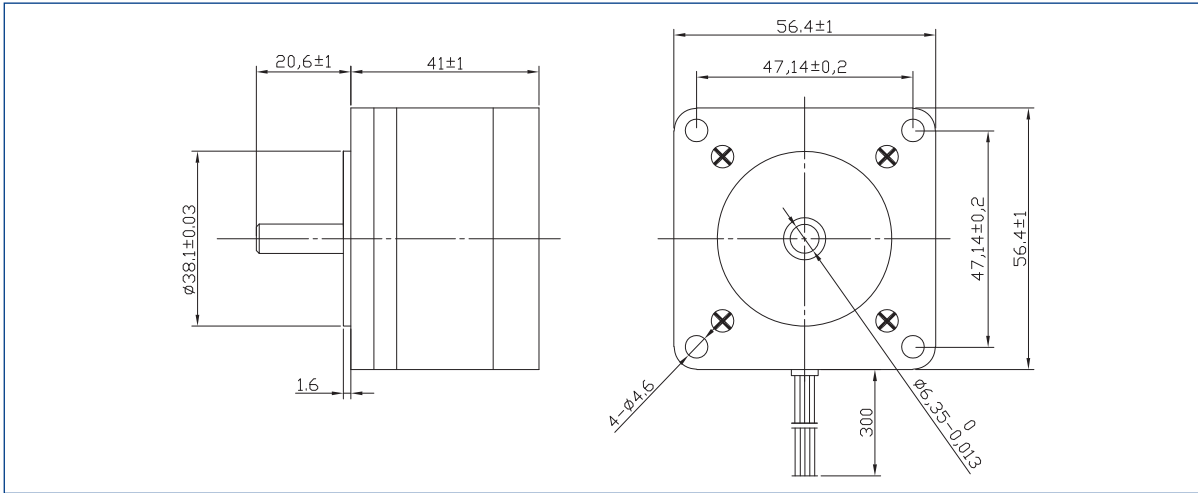

CE

Characteristics

STEP ANGLE
1,8°

STEP ANGLE ACCURACY
± 5%

INSULATION CLASS
B

AMBIENT TEMPERATURE
-20°C +50°C

TEMP. RISE
80°C MAX (RATED CURRENT, 2 PHASE ON)

INSULATION RESISTANCE
100 M OHM MIN. 500 VDC

DIELECTRIC STRENGTH
500 VAC FOR ONE MINUTE

SHAFT RADIAL PLAY
0,02 MAX (450 G LOAD)

SHAFT AXIAL PLAY
0,08 MAX. (450 G LOAD)

MAX RADIAL FORCE
75 N (20 MM FROM FRONT FLANGE)

MAX AXIAL FORCE
15 N

Specification

Model		57S41-1A	57S41-2A	57S41-4A
1 RATED VOLTAGE	V	4	12	2,8
2 CURRENT/PHASE	A	1,1	0,4	1,56
3 RESISTANCE/PHASE	Ω	3,6	30	1,8
4 INDUCTANCE/PHASE	mH	3,6	30	3,6
5 HOLDING TORQUE	NM	0,288	0,288	0,4
6 ROTOR INERTIA	G-CM ²	57	57	57
7 WEIGHT	KG	0,54	0,54	0,54
8 NUMBER OF LEADS	N°	6	6	4

Speed vs. Torque Characteristics

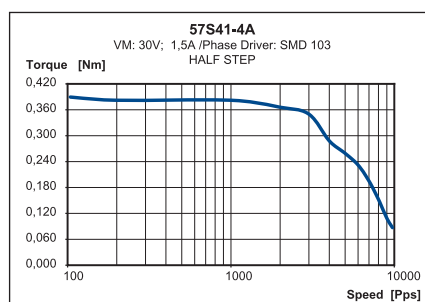
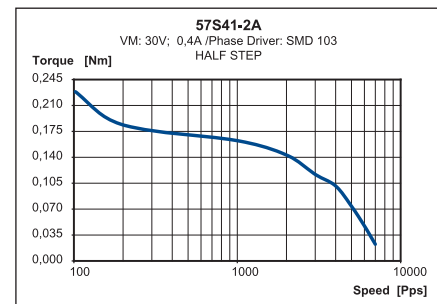
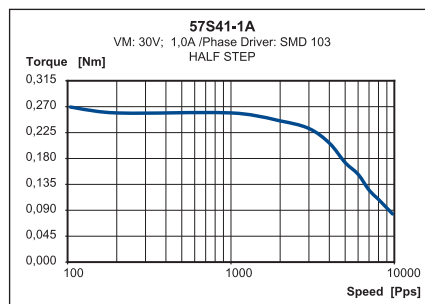

Connection

LEAD N°	COLOR	GAUGE	FUNCTION
1	BLACK	UL1430 AWG22	PHASE A
2	GREEN	UL1430 AWG22	PHASE A-
3	RED	UL1430 AWG22	PHASE B
4	BLUE	UL1430 AWG22	PHASE B-
UNIPOLAR MOTOR			
5	YELLOW	UL1430 AWG22	COM PHASE A
6	WHITE	UL1430 AWG22	COM PHASE B

Stepper MOTOR

57S51 Hybrid

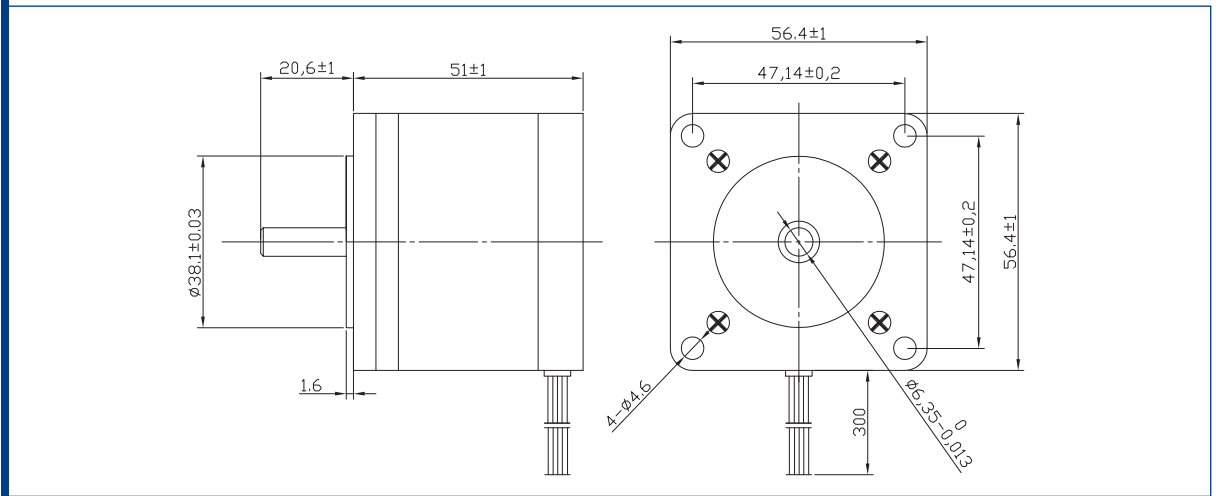

Specification

Model		57S51-1A	57S51-2A	57S51-4A
1 RATED VOLTAGE	V	6	12	2,38
2 CURRENT/PHASE	A	0,85	0,42	2,8
3 RESISTANCE/PHASE	Ω	7,1	29	0,85
4 INDUCTANCE/PHASE	mH	9	36	2,1
5 HOLDING TORQUE	Nm	0,497	0,497	0,69
6 ROTOR INERTIA	g-cm ²	110	110	110
7 WEIGHT	KG	0,6	0,6	0,6
8 NUMBER OF LEADS	N°	6	6	4

Speed vs. Torque Characteristics

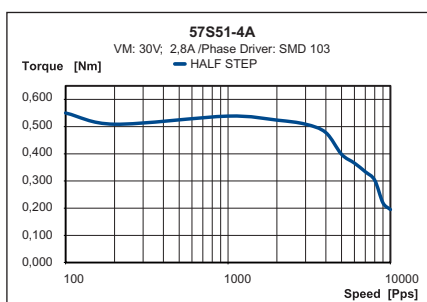
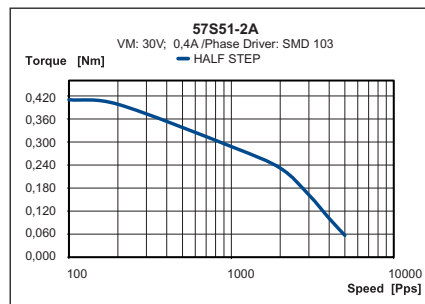
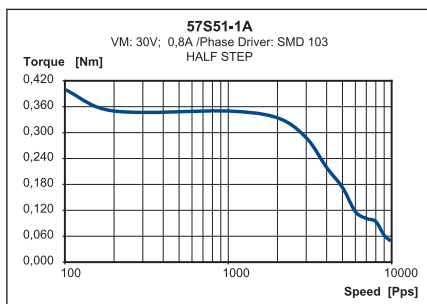

Characteristics

STEP ANGLE
1,8°

STEP ANGLE ACCURACY
± 5%

INSULATION CLASS
B

AMBIENT TEMPERATURE
-20°C +50°C

TEMP. RISE
80°C MAX (RATED CURRENT, 2 PHASE ON)

INSULATION RESISTANCE
100 M OHM MIN. 500 VDC

DIELECTRIC STRENGTH
500 VAC FOR ONE MINUTE

SHAFT RADIAL PLAY
0,02 MAX (450 G LOAD)

SHAFT AXIAL PLAY
0,08 MAX. (450 G LOAD)

MAX RADIAL FORCE
75 N (20 MM FROM FRONT FLANGE)

MAX AXIAL FORCE
15 N

Connection

LEAD N°	COLOR	GAUGE	FUNCTION
1	BLACK	UL1430 AWG22	PHASE A
2	GREEN	UL1430 AWG22	PHASE A-
3	RED	UL1430 AWG22	PHASE B
4	BLUE	UL1430 AWG22	PHASE B-

UNIPOLAR MOTOR

5	YELLOW	UL1430 AWG22	COM PHASE A
6	WHITE	UL1430 AWG22	COM PHASE B

Stepper MOTOR

57S56 Hybrid

57S56 Hybrid

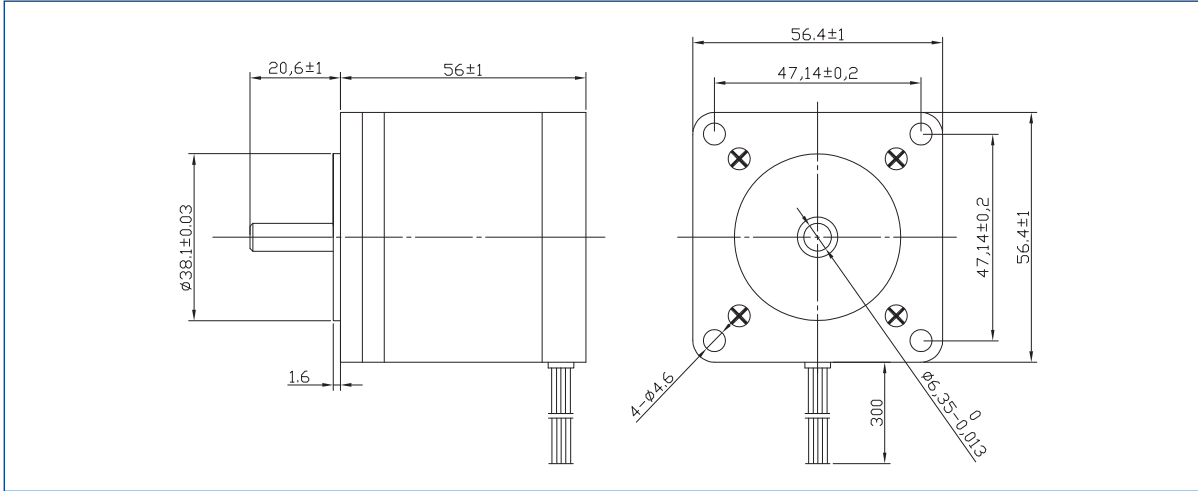

Characteristics

STEP ANGLE
1,8°

STEP ANGLE ACCURACY
± 5%

INSULATION CLASS
B

AMBIENT TEMPERATURE
-20°C +50°C

TEMP. RISE
80°C MAX (RATED CURRENT, 2 PHASE ON)

INSULATION RESISTANCE
100 M OHM MIN. 500 VDC

DIELECTRIC STRENGTH
500 VAC FOR ONE MINUTE

SHAFT RADIAL PLAY
0,02 MAX (450 G LOAD)

SHAFT AXIAL PLAY
0,08 MAX. (450 G LOAD)

MAX RADIAL FORCE
75 N (20 MM FROM FRONT FLANGE)

MAX AXIAL FORCE
15 N

Specification

Model		57S56-1A	57S56-2A	57S56-4A
1 RATED VOLTAGE	V	6	12	2,8
2 CURRENT/PHASE	A	1,2	0,6	2,5
3 RESISTANCE/PHASE	Ω	5	20	1,1
4 INDUCTANCE/PHASE	mH	8	32	3,6
5 HOLDING TORQUE	NM	0,605	0,605	0,84
6 ROTOR INERTIA	g·cm ²	135	135	135
7 WEIGHT	Kg	0,65	0,65	0,65
8 NUMBER OF LEADS	N°	6	6	4

Speed vs. Torque Characteristics

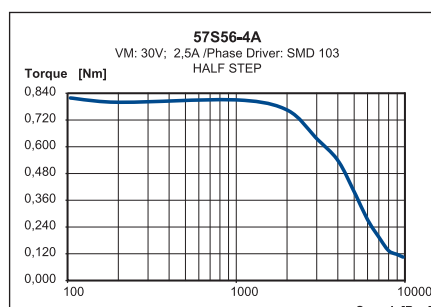
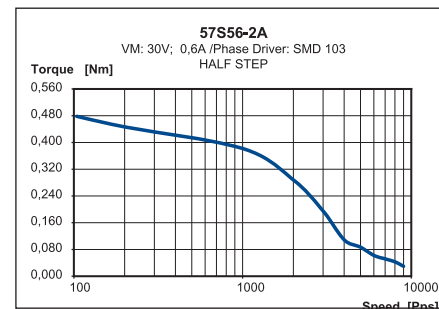
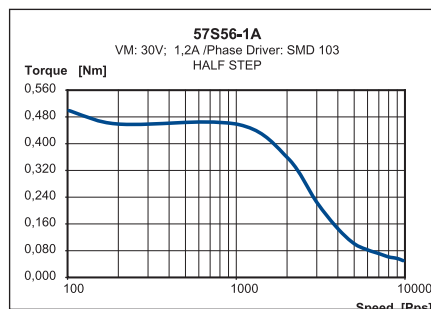

Connection

LEAD N°	COLOR	GAUGE	FUNCTION
1	BLACK	UL1430 AWG22	PHASE A
2	GREEN	UL1430 AWG22	PHASE A-
3	RED	UL1430 AWG22	PHASE B
4	BLUE	UL1430 AWG22	PHASE B-
UNIPOLAR MOTOR			
5	YELLOW	UL1430 AWG22	COM PHASE A
6	WHITE	UL1430 AWG22	COM PHASE B

Stepper MOTOR

57S76 Hybrid

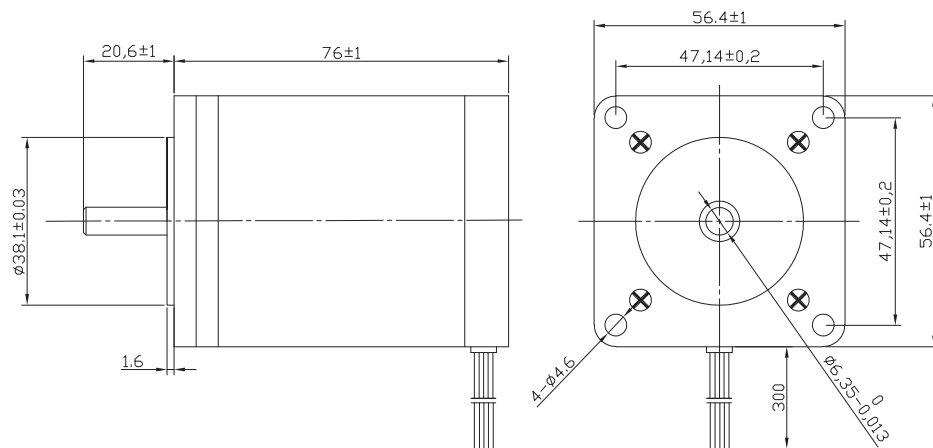

Specification

Model		57S76-1A	57S76-2A	57S76-4A
1 RATED VOLTAGE	V	5,4	12	2,8
2 CURRENT/PHASE	A	1,5	0,68	3,3
3 RESISTANCE/PHASE	Ω	3,6	17,7	0,85
4 INDUCTANCE/PHASE	mH	6	30	3
5 HOLDING TORQUE	Nm	0,9	0,9	1,25
6 ROTOR INERTIA	g-cm ²	200	200	200
7 WEIGHT	Kg	0,95	0,95	0,95
8 NUMBER OF LEADS	N°	6	6	4

Speed vs. Torque Characteristics

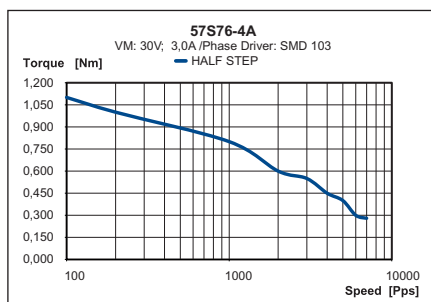
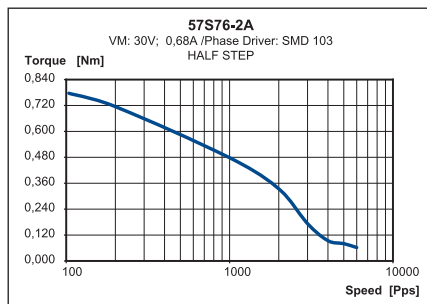
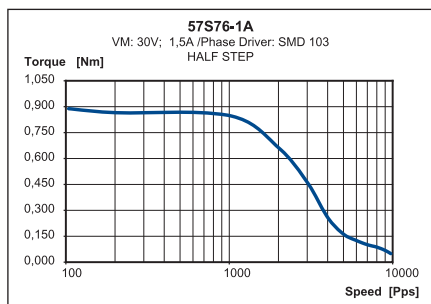

Characteristics

STEP ANGLE
1,8°

STEP ANGLE ACCURACY
± 5%

INSULATION CLASS
B

AMBIENT TEMPERATURE
-20°C +50°C

TEMP. RISE
80°C MAX (RATED CURRENT, 2 PHASE ON)

INSULATION RESISTANCE
100 M OHM MIN. 500 VDC

DIELECTRIC STRENGTH
500 VAC FOR ONE MINUTE

SHAFT RADIAL PLAY
0,02 MAX (450 G LOAD)

SHAFT AXIAL PLAY
0,08 MAX. (450 G LOAD)

MAX RADIAL FORCE
75 N (20 MM FROM FRONT FLANGE)

MAX AXIAL FORCE
15 N

Connection

LEAD N°	COLOR	GAUGE	FUNCTION
1	BLACK	UL1430 AWG22	PHASE A
2	GREEN	UL1430 AWG22	PHASE A-
3	RED	UL1430 AWG22	PHASE B
4	BLUE	UL1430 AWG22	PHASE B-
UNIPOLAR MOTOR			
5	YELLOW	UL1430 AWG22	COM PHASE A
6	WHITE	UL1430 AWG22	COM PHASE B

Stepper MOTOR

57SH41 High Torque Hybrid

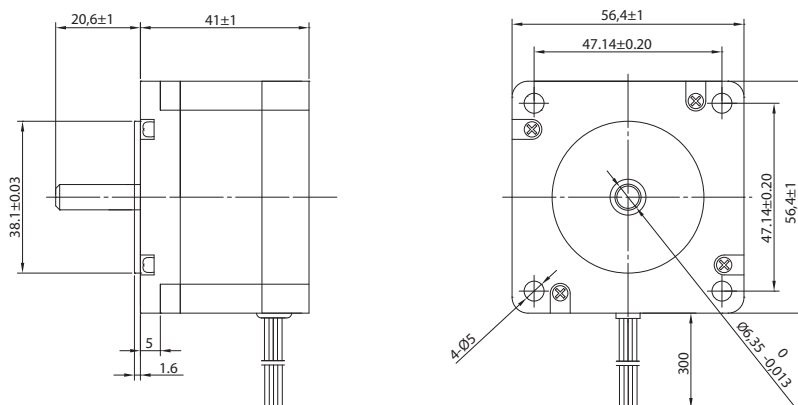

Characteristics

STEP ANGLE
1,8°

STEP ANGLE ACCURACY
± 5%

INSULATION CLASS
B

AMBIENT TEMPERATURE
-20°C +50°C

TEMP. RISE
80°C MAX (RATED CURRENT, 2 PHASE ON)

INSULATION RESISTANCE
100 M OHM MIN. 500 VDC

DIELECTRIC STRENGTH
500 VAC FOR ONE MINUTE

SHAFT RADIAL PLAY
0,02 MAX (450 G LOAD)

SHAFT AXIAL PLAY
0,08 MAX. (450 G LOAD)

MAX RADIAL FORCE
75 N (20 MM FROM FRONT FLANGE)

MAX AXIAL FORCE
15 N

Specification

Model		57SH41-1A	57SH41-2A	57SH41-3A	57SH41-4A	
1	RATED VOLTAGE	V	5,7	2,8	1,9	2
2	CURRENT/PHASE	A	1	2	3	2,8
3	RESISTANCE/PHASE	Ω	5,7	1,4	0,63	0,7
4	INDUCTANCE/PHASE	mH	5,4	1,4	0,6	1,4
5	HOLDING TORQUE	NM	0,39	0,39	0,39	0,55
6	ROTOR INERTIA	G-CM ²	120	120	120	120
7	WEIGHT	KG	0,45	0,45	0,45	0,45
8	NUMBER OF LEADS	N°	6	6	6	4

Speed vs. Torque Characteristics

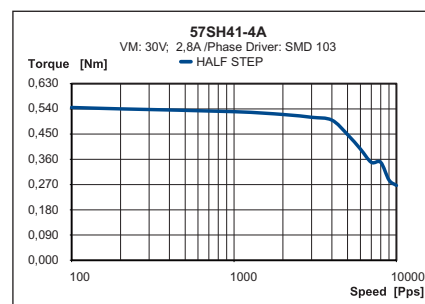
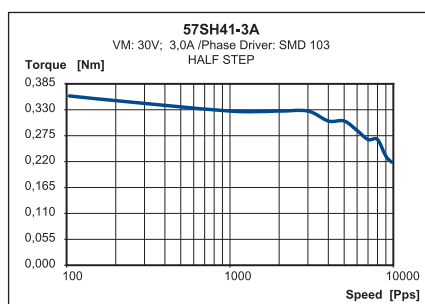
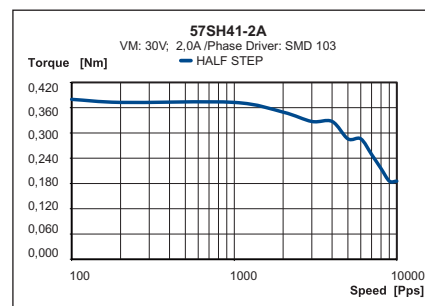
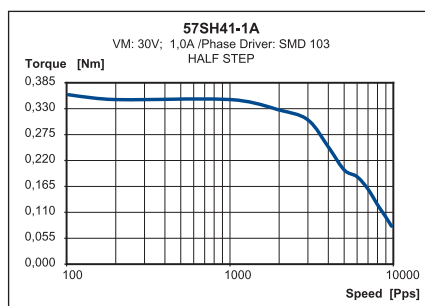

Connection

LEAD N°	COLOR	GAUGE	FUNCTION
1	BLACK	UL1430 AWG22	PHASE A
2	GREEN	UL1430 AWG22	PHASE A-
3	RED	UL1430 AWG22	PHASE B
4	BLUE	UL1430 AWG22	PHASE B-
UNIPOLAR MOTOR			
5	YELLOW	UL1430 AWG22	COM PHASE A
6	WHITE	UL1430 AWG22	COM PHASE B

Stepper MOTOR

57SH51 High Torque Hybrid

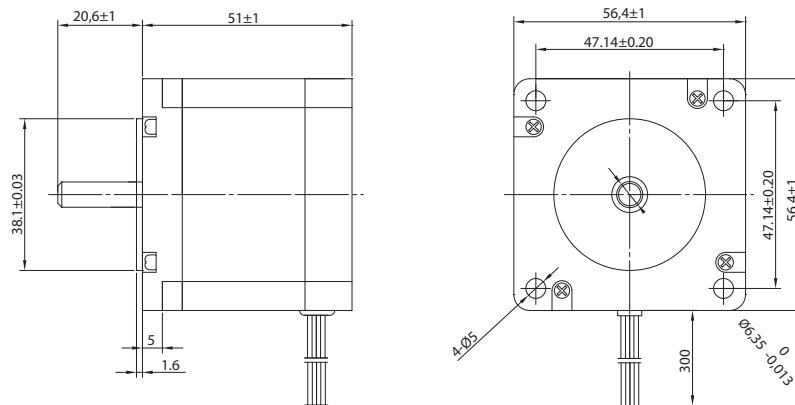

Specification

Model		57SH51-1A	57SH51-2A	57SH51-3A	57SH51-4A
1 RATED VOLTAGE	V	6,6	3,3	2,2	2,3
2 CURRENT/PHASE	A	1	2	3	2,8
3 RESISTANCE/PHASE	Ω	6,6	1,65	0,74	0,83
4 INDUCTANCE/PHASE	mH	8,2	2,2	0,9	2,2
5 HOLDING TORQUE	NM	0,72	0,72	0,72	1,01
6 ROTOR INERTIA	g·CM ²	275	275	275	275
7 WEIGHT	KG	0,65	0,65	0,65	0,65
8 NUMBER OF LEADS	N°	6	6	6	4

Speed vs. Torque Characteristics

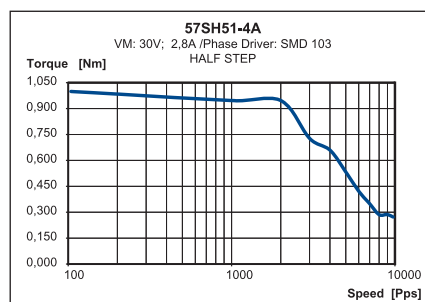
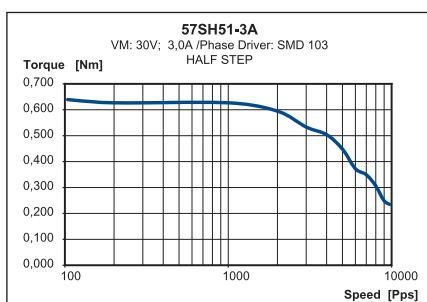
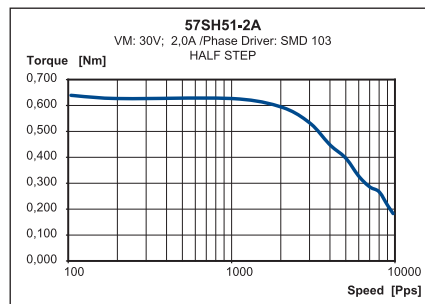
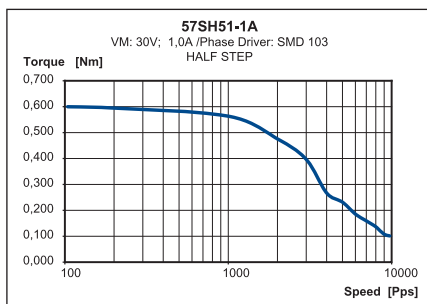

Characteristics

STEP ANGLE
1,8°

STEP ANGLE ACCURACY
± 5%

INSULATION CLASS
B

AMBIENT TEMPERATURE
-20°C +50°C

TEMP. RISE
80°C MAX (RATED CURRENT, 2 PHASE ON)

INSULATION RESISTANCE
100 M OHM MIN. 500 VDC

DIELECTRIC STRENGTH
500 VAC FOR ONE MINUTE

SHAFT RADIAL PLAY
0,02 MAX (450 G LOAD)

SHAFT AXIAL PLAY
0,08 MAX. (450 G LOAD)

MAX RADIAL FORCE
75 N (20 MM FROM FRONT FLANGE)

MAX AXIAL FORCE
15 N

Connection

LEAD N°	COLOR	GAUGE	FUNCTION
1	BLACK	UL1430 AWG22	PHASE A
2	GREEN	UL1430 AWG22	PHASE A-
3	RED	UL1430 AWG22	PHASE B
4	BLUE	UL1430 AWG22	PHASE B-
UNIPOLAR MOTOR			
5	YELLOW	UL1430 AWG22	COM PHASE A
6	WHITE	UL1430 AWG22	COM PHASE B

Stepper MOTOR

57SH56 High Torque Hybrid

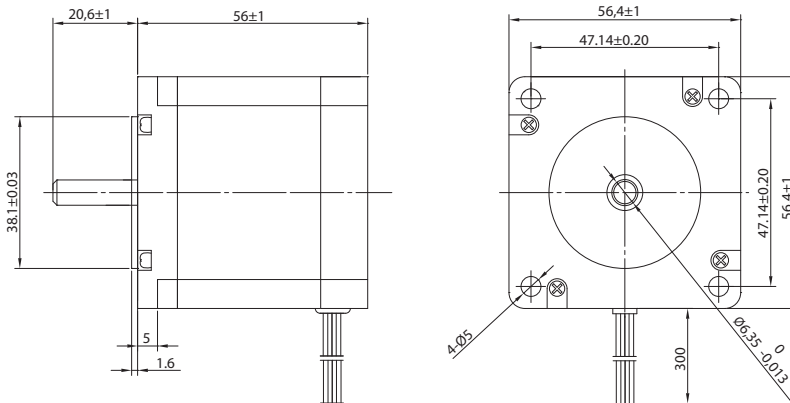

Characteristics

STEP ANGLE
1,8°

STEP ANGLE ACCURACY
± 5%

INSULATION CLASS
B

AMBIENT TEMPERATURE
-20°C +50°C

TEMP. RISE
80°C MAX (RATED CURRENT, 2 PHASE ON)

INSULATION RESISTANCE
100 M OHM MIN. 500 VDC

DIELECTRIC STRENGTH
500 VAC FOR ONE MINUTE

SHAFT RADIAL PLAY
0,02 MAX (450 G LOAD)

SHAFT AXIAL PLAY
0,08 MAX. (450 G LOAD)

MAX RADIAL FORCE
75 N (20 MM FROM FRONT FLANGE)

MAX AXIAL FORCE
15 N

Specification

Model		57SH56-1A	57SH56-2A	57SH56-3A	57SH56-4A	
1	RATED VOLTAGE	V	7,4	3,6	2,3	2,5
2	CURRENT/PHASE	A	1	2	3	2,8
3	RESISTANCE/PHASE	Ω	7,4	1,8	0,75	0,9
4	INDUCTANCE/PHASE	mH	10	2,5	1,1	2,5
5	HOLDING TORQUE	NM	0,9	0,9	0,9	1,26
6	ROTOR INERTIA	G-CM ²	300	300	300	300
7	WEIGHT	KG	0,7	0,7	0,7	0,7
8	NUMBER OF LEADS	N°	6	6	6	4

Speed vs. Torque Characteristics

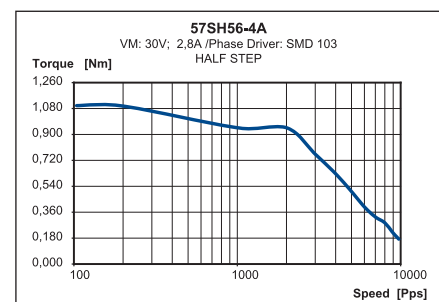
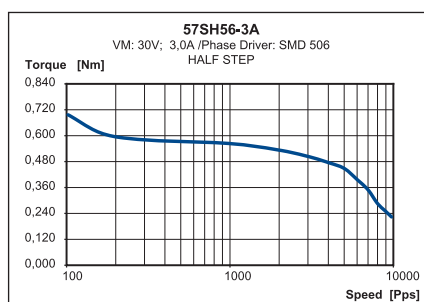
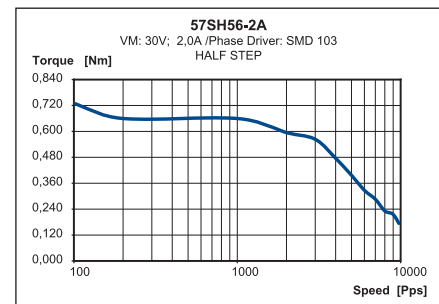
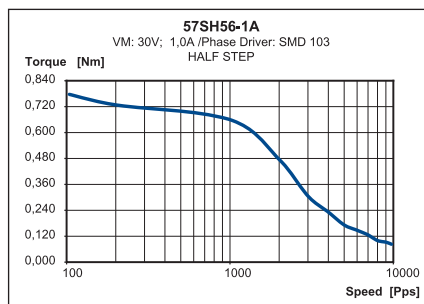

Connection

LEAD N°	COLOR	GAUGE	FUNCTION
1	BLACK	UL1430 AWG22	PHASE A
2	GREEN	UL1430 AWG22	PHASE A-
3	RED	UL1430 AWG22	PHASE B
4	BLUE	UL1430 AWG22	PHASE B-
UNIPOLAR MOTOR			
5	YELLOW	UL1430 AWG22	COM PHASE A
6	WHITE	UL1430 AWG22	COM PHASE B

Stepper MOTOR

57SH76 High Torque Hybrid

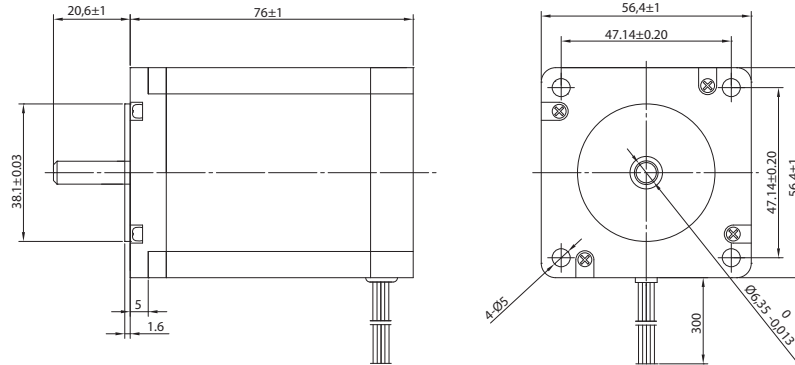

Specification

Model		57SH76-1A	57SH76-2A	57SH76-3A	57SH76-4A
1 RATED VOLTAGE	V	8,6	4,5	3	3,2
2 CURRENT/PHASE	A	1	2	3	2,8
3 RESISTANCE/PHASE	Ω	8,6	2,25	1	1,13
4 INDUCTANCE/PHASE	mH	14	3,6	1,6	3,6
5 HOLDING TORQUE	NM	1,35	1,35	1,35	1,89
6 ROTOR INERTIA	g-CM ²	480	480	480	480
7 WEIGHT	KG	1	1	1	1
8 NUMBER OF LEADS	N°	6	6	6	4

Speed vs. Torque Characteristics

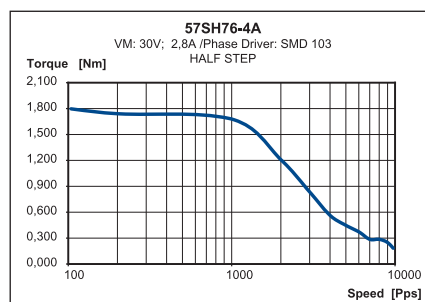
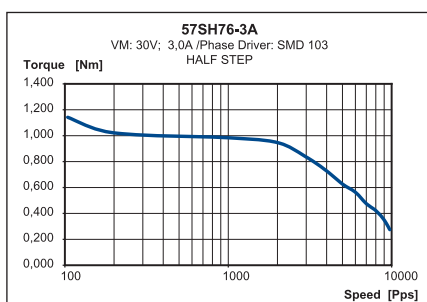
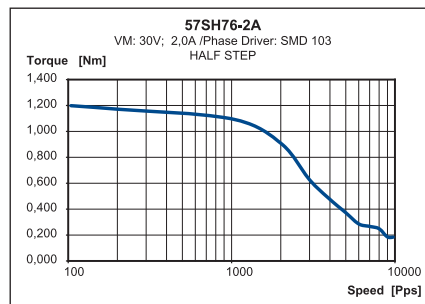
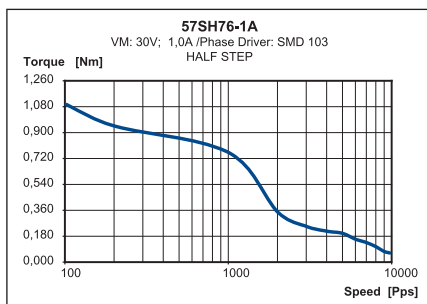

Characteristics

STEP ANGLE
1,8°

STEP ANGLE ACCURACY
± 5%

INSULATION CLASS
B

AMBIENT TEMPERATURE
-20°C +50°C

TEMP. RISE
80°C MAX (RATED CURRENT, 2 PHASE ON)

INSULATION RESISTANCE
100 M OHM MIN. 500 VDC

DIELECTRIC STRENGTH
500 VAC FOR ONE MINUTE

SHAFT RADIAL PLAY
0,02 MAX (450 G LOAD)

SHAFT AXIAL PLAY
0,08 MAX. (450 G LOAD)

MAX RADIAL FORCE
75 N (20 MM FROM FRONT FLANGE)

MAX AXIAL FORCE
15 N

Connection

LEAD N°	COLOR	GAUGE	FUNCTION
1	BLACK	UL1430 AWG22	PHASE A
2	GREEN	UL1430 AWG22	PHASE A-
3	RED	UL1430 AWG22	PHASE B
4	BLUE	UL1430 AWG22	PHASE B-
UNIPOLAR MOTOR			
5	YELLOW	UL1430 AWG22	COM PHASE A
6	WHITE	UL1430 AWG22	COM PHASE B

Stepper MOTOR

57SH41-M High Torque Hybrid

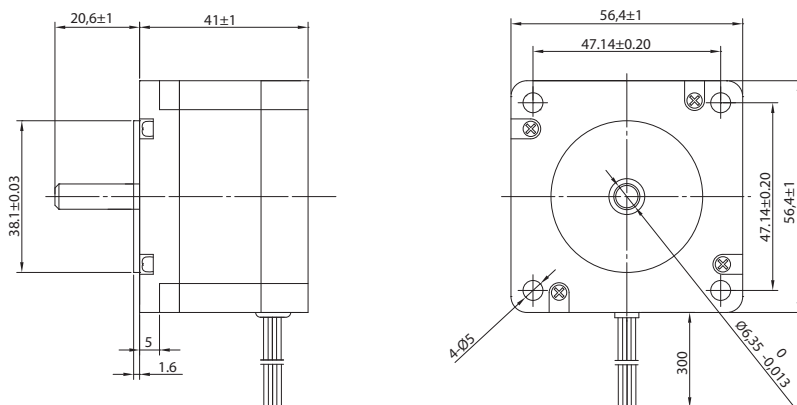

Characteristics

STEP ANGLE
0,9°

STEP ANGLE ACCURACY
± 5%

INSULATION CLASS
B

AMBIENT TEMPERATURE
-20°C +50°C

TEMP. RISE
80°C MAX (RATED CURRENT, 2 PHASE ON)

INSULATION RESISTANCE
100 M OHM MIN. 500 VDC

DIELECTRIC STRENGTH
500 VAC FOR ONE MINUTE

SHAFT RADIAL PLAY
0,02 MAX (450 G LOAD)

SHAFT AXIAL PLAY
0,08 MAX. (450 G LOAD)

MAX RADIAL FORCE
75 N (20 MM FROM FRONT FLANGE)

MAX AXIAL FORCE
15 N

Specification

Model		57SH41-1AM	57SH41-2AM	57SH41-3AM	57SH41-4AM	
1	RATED VOLTAGE	V	5,7	2,8	1,9	2
2	CURRENT/PHASE	A	1	2	3	2,8
3	RESISTANCE/PHASE	Ω	5,7	1,4	0,63	0,7
4	INDUCTANCE/PHASE	mH	8	2,2	1	2,2
5	HOLDING TORQUE	NM	0,39	0,39	0,39	0,55
6	ROTOR INERTIA	G-CM ²	120	120	120	120
7	WEIGHT	KG	0,45	0,45	0,45	0,45
8	NUMBER OF LEADS	N°	6	6	6	4

Speed vs. Torque Characteristics

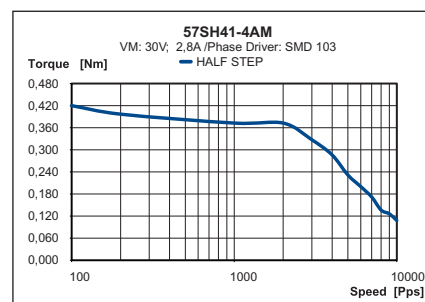
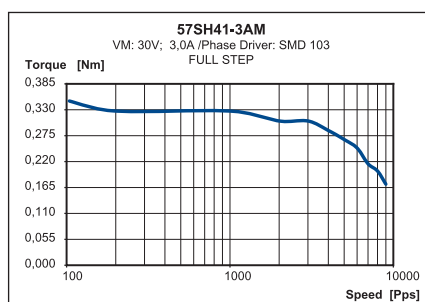
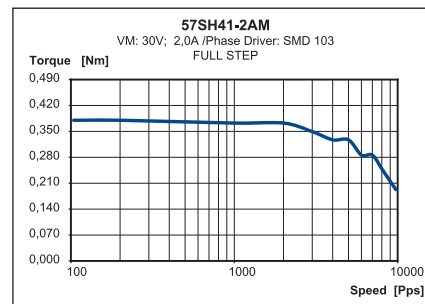
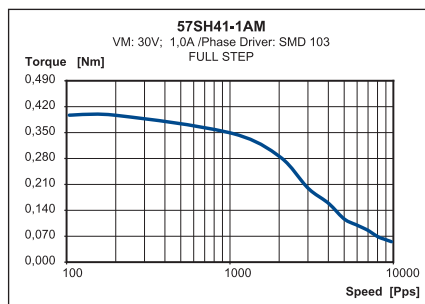

Connection

LEAD N°	COLOR	GAUGE	FUNCTION
1	BLACK	UL1430 AWG22	PHASE A
2	GREEN	UL1430 AWG22	PHASE A-
3	RED	UL1430 AWG22	PHASE B
4	BLUE	UL1430 AWG22	PHASE B-
UNIPOLAR MOTOR			
5	YELLOW	UL1430 AWG22	COM PHASE A
6	WHITE	UL1430 AWG22	COM PHASE B

Stepper MOTOR

57SH56-M High Torque Hybrid

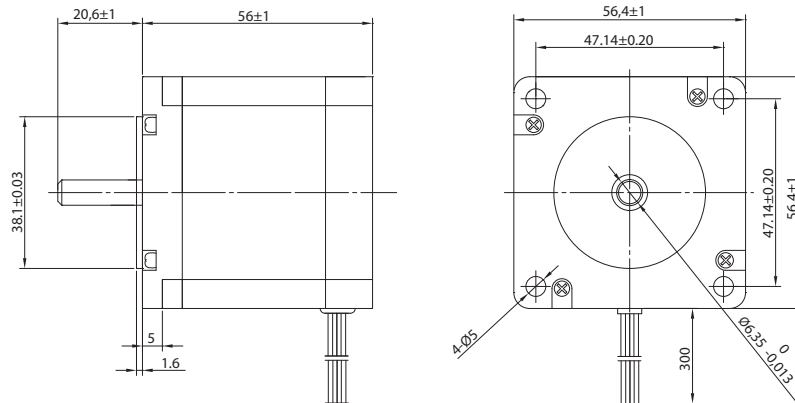

Specification

Model		57SH56-1AM	57SH56-2AM	57SH56-3AM	57SH56-4AM
1 RATED VOLTAGE	V	7,4	3,6	2,3	2,5
2 CURRENT/PHASE	A	1	2	3	2,8
3 RESISTANCE/PHASE	Ω	7,4	1,8	0,75	0,9
4 INDUCTANCE/PHASE	mH	17,5	4,5	1,9	4,5
5 HOLDING TORQUE	NM	0,9	0,9	0,9	1,26
6 ROTOR INERTIA	g-CM ²	300	300	300	300
7 WEIGHT	KG	0,7	0,7	0,7	0,7
8 NUMBER OF LEADS	N°	6	6	6	4

Speed vs. Torque Characteristics

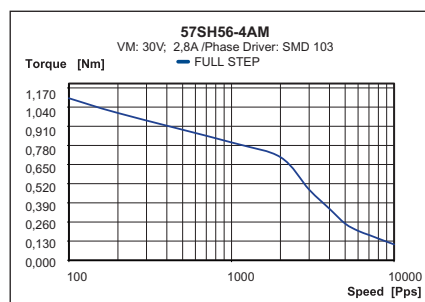
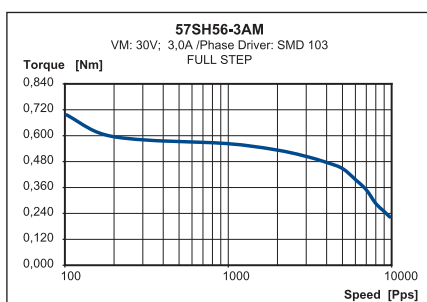
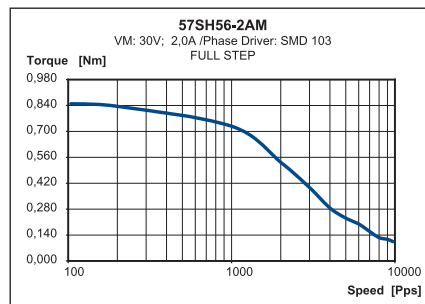
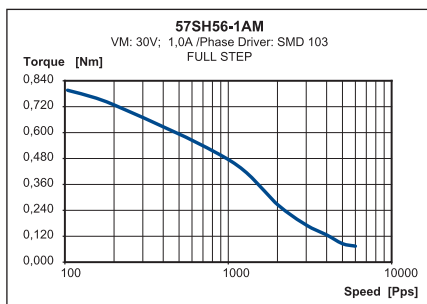

Characteristics

- STEP ANGLE
0,9°
- STEP ANGLE ACCURACY
± 5%
- INSULATION CLASS
B
- AMBIENT TEMPERATURE
-20°C +50°C
- TEMP. RISE
80°C MAX (RATED CURRENT, 2 PHASE ON)
- INSULATION RESISTANCE
100 M OHM MIN. 500 VDC
- DIELECTRIC STRENGTH
500 VAC FOR ONE MINUTE
- SHAFT RADIAL PLAY
0,02 MAX (450 G LOAD)
- SHAFT AXIAL PLAY
0,08 MAX. (450 G LOAD)
- MAX RADIAL FORCE
75 N (20 MM FROM FRONT FLANGE)
- MAX AXIAL FORCE
15 N

Connection

LEAD N°	COLOR	GAUGE	FUNCTION
1	BLACK	UL1430 AWG22	PHASE A
2	GREEN	UL1430 AWG22	PHASE A-
3	RED	UL1430 AWG22	PHASE B
4	BLUE	UL1430 AWG22	PHASE B-
UNIPOLAR MOTOR			
5	YELLOW	UL1430 AWG22	COM PHASE A
6	WHITE	UL1430 AWG22	COM PHASE B

Stepper MOTOR

57SH76-M High Torque Hybrid

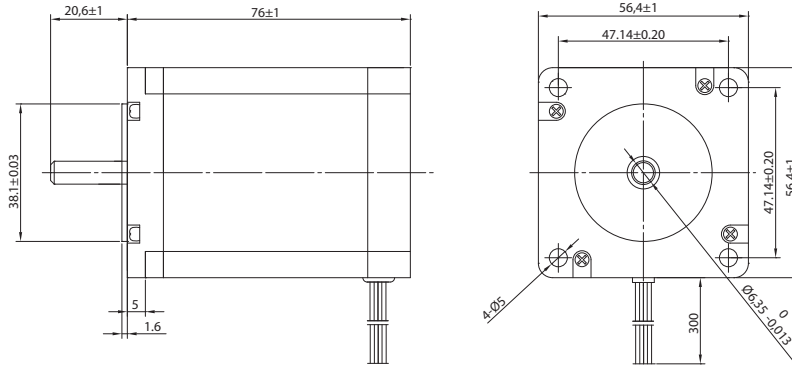

Characteristics

STEP ANGLE
0,9°

STEP ANGLE ACCURACY
± 5%

INSULATION CLASS
B

AMBIENT TEMPERATURE
-20°C +50°C

TEMP. RISE
80°C MAX (RATED CURRENT, 2 PHASE ON)

INSULATION RESISTANCE
100 M OHM MIN. 500 VDC

DIELECTRIC STRENGTH
500 VAC FOR ONE MINUTE

SHAFT RADIAL PLAY
0,02 MAX (450 G LOAD)

SHAFT AXIAL PLAY
0,08 MAX. (450 G LOAD)

MAX RADIAL FORCE
75 N (20 MM FROM FRONT FLANGE)

MAX AXIAL FORCE
15 N

Specification

Model		57SH76-1AM	57SH76-2AM	57SH76-3AM	57SH76-4AM
1 RATED VOLTAGE	V	8,6	4,5	3	3,2
2 CURRENT/PHASE	A	1	2	3	2,8
3 RESISTANCE/PHASE	Ω	8,6	2,25	1	1,13
4 INDUCTANCE/PHASE	mH	23	5,6	2,6	5,6
5 HOLDING TORQUE	NM	1,35	1,35	1,35	1,89
6 ROTOR INERTIA	G-CM ²	480	480	480	480
7 WEIGHT	KG	1	1	1	1
8 NUMBER OF LEADS	N°	6	6	6	4

Speed vs. Torque Characteristics

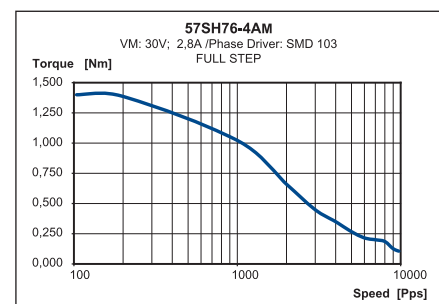
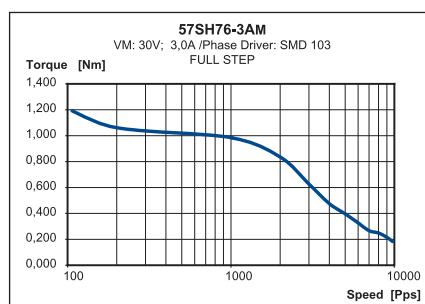
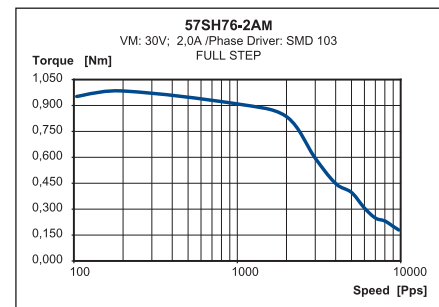
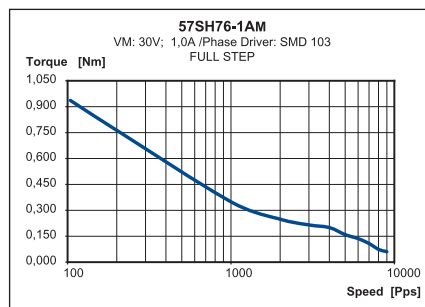

Connection

LEAD N°	COLOR	GAUGE	FUNCTION
1	BLACK	UL1430 AWG22	PHASE A
2	GREEN	UL1430 AWG22	PHASE A-
3	RED	UL1430 AWG22	PHASE B
4	BLUE	UL1430 AWG22	PHASE B-
UNIPOLAR MOTOR			
5	YELLOW	UL1430 AWG22	COM PHASE A
6	WHITE	UL1430 AWG22	COM PHASE B

Stepper MOTOR

60SH High Torque Hybrid

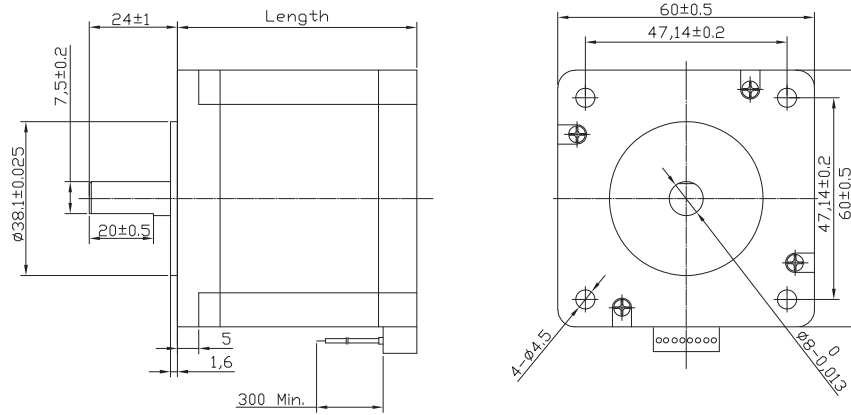

Specification

Model	60SH45-2008AF			60SH56-2008AF			60SH65-2008AF			60SH86-2008AF		
	UNIPOLAR	PARALLEL	SERIES	UNIPOLAR	PARALLEL	SERIES	UNIPOLAR	PARALLEL	SERIES	UNIPOLAR	PARALLEL	SERIES
1 RATED VOLTAGE V	3	2,1	4,2	3,6	2,52	5,04	4,8	3,36	6,72	6	4,17	8,4
2 CURRENT/PHASE A	2	2,8	1,4	2	2,8	1,4	2	2,8	1,4	2	2,8	1,4
3 RESISTANCE/PHASE Ω	1,5	0,75	3	1,8	0,9	3,6	2,4	1,2	4,8	3	1,5	6
4 INDUCTANCE/PHASE mH	2	2	8	3,6	3,6	14,4	4,6	4,6	18,4	6,8	6,8	27,2
5 HOLDING TORQUE Nm	0,78	1,1	1,1	1,17	1,65	1,65	1,5	2,1	2,1	2,2	3,1	3,1
6 ROTOR INERTIA g-cm ²	275			400			570			840		
7 WEIGHT Kg	0,6			0,77			1,2			1,4		
8 NUMBER OF LEADS N°	8			8			8			8		
9 LENGTH MM	45			56			65			86		

Speed vs. Torque Characteristics

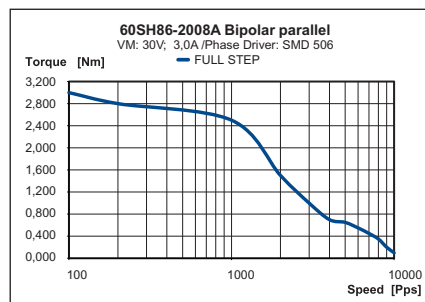
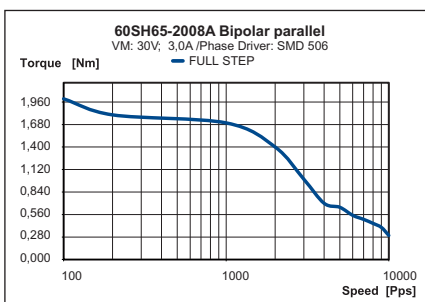
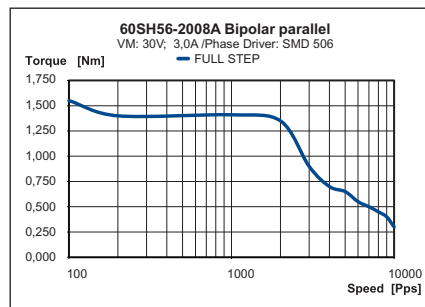
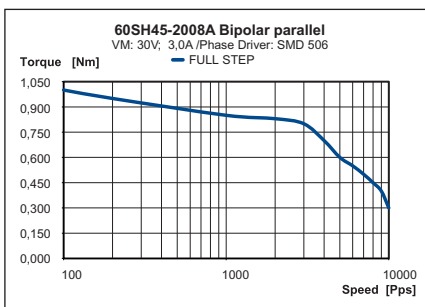

Characteristics

STEP ANGLE
1,8°

STEP ANGLE ACCURACY
± 5%

INSULATION CLASS
B

AMBIENT TEMPERATURE
-20°C +50°C

TEMP. RISE
80°C MAX (RATED CURRENT, 2 PHASE ON)

INSULATION RESISTANCE
100 M OHM MIN. 500 VDC

DIELECTRIC STRENGTH
500 VAC FOR ONE MINUTE

SHAFT RADIAL PLAY
0,02 MAX (450 G LOAD)

SHAFT AXIAL PLAY
0,08 MAX. (450 G LOAD)

MAX RADIAL FORCE
75 N (20 MM FROM FRONT FLANGE)

MAX AXIAL FORCE
15 N

Connection

LEAD N°	COLOR	GAUGE	FUNCTION
1	BLUE/WHITE	UL1430 AWG22	PHASE A
2	BLUE	UL1430 AWG22	PHASE A-
3	RED/WHITE	UL1430 AWG22	PHASE C-
4	RED	UL1430 AWG22	PHASE C
5	GREEN/WHITE	UL1430 AWG22	PHASE B
6	GREEN	UL1430 AWG22	PHASE B-
7	BLACK/WHITE	UL1430 AWG22	PHASE D-
8	BLACK	UL1430 AWG22	PHASE D

Stepper MOTOR

63S10-1004A Flat Hybrid Stepper

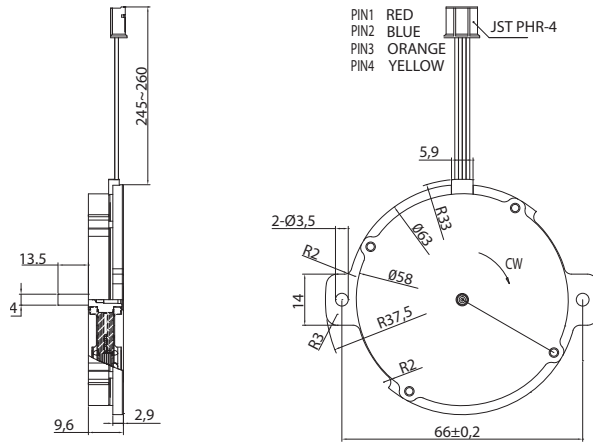

Characteristics

STEP ANGLE
1,8°

STEP ANGLE ACCURACY
± 5%

INSULATION CLASS
E

AMBIENT TEMPERATURE
-10°C +50°C

TEMP. RISE
75°C MAX (RATED CURRENT, 2 PHASE ON)

INSULATION RESISTANCE
100 M OHM MIN. 500 VDC

DIELECTRIC STRENGTH
500 VAC FOR ONE MINUTE

SHAFT RADIAL PLAY
0,06 MAX (450 G LOAD)

SHAFT AXIAL PLAY
0,04 MAX. (450 G LOAD)

MAX RADIAL FORCE
4.5 N (20 MM FROM FRONT FLANGE)

MAX AXIAL FORCE
4.5 N

Specification

Model	63S10-1004A	
1 RATED VOLTAGE	V	3,8
2 CURRENT/PHASE	A	1
3 RESISTANCE/PHASE	Ω	3,8
4 INDUCTANCE/PHASE	mH	2
5 HOLDING TORQUE	Nm	0,064
6 ROTOR INERTIA	g-cm ²	16
7 WEIGHT	Kg	0,095
8 NUMBER OF LEADS	N°	4

Connection

LEAD N°	COLOR	GAUGE	FUNCTION
1	RED	UL1061 AWG26	PHASE A
2	BLUE	UL1061 AWG26	PHASE A-
3	ORANGE	UL1061 AWG26	PHASE B
4	YELLOW	UL1061 AWG26	PHASE B-

Speed vs. Torque Characteristics

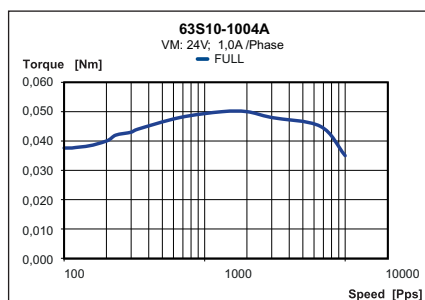

Stepper MOTOR

86S Hybrid

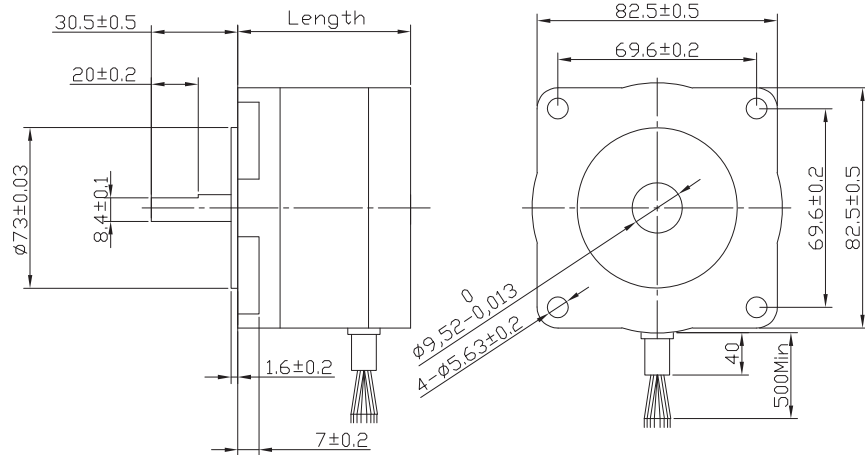

Specification

	Model	86S67-2808A			86S94-2808A			86S125-3508A			
		UNIPOLAR	PARALLEL	SERIES	UNIPOLAR	PARALLEL	SERIES	UNIPOLAR	PARALLEL	SERIES	
1	RATED VOLTAGE	V	3,64	2,54	5	4,76	2,54	6,6	4,97	3,47	6,95
2	CURRENT/PHASE	A	2,8	3,92	1,96	2,8	3,92	1,96	3,5	4,9	2,45
3	RESISTANCE/PHASE	Ω	1,3	0,65	2,6	1,7	0,85	3,4	1,42	0,71	2,84
4	INDUCTANCE/PHASE	MH	5,1	5,1	20,4	7,7	7,7	30,8	7,9	7,9	31,6
5	HOLDING TORQUE	Nm	2,3	2,8	2,8	3,8	4,8	4,8	6,2	7,6	7,6
6	ROTOR INERTIA	g·cm ²		660			1200			1800	
7	WEIGHT	Kg		1,6			2,4			3,6	
8	NUMBER OF LEADS	N°		8			8			8	
9	LENGTH	MM		67			94			125	

Speed vs. Torque Characteristics

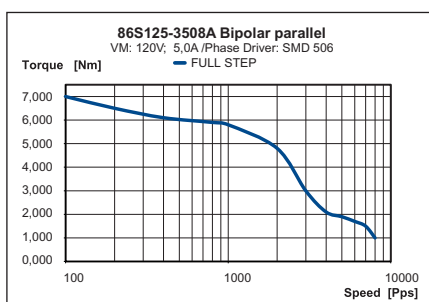
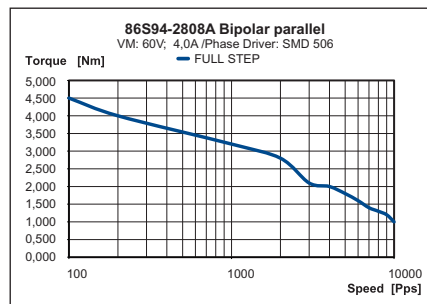
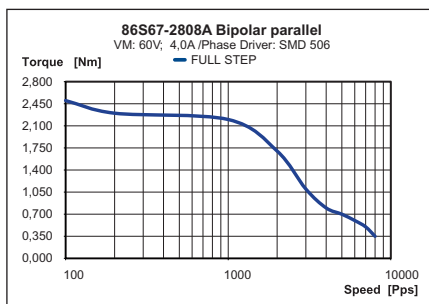

Characteristics

STEP ANGLE
1,8°

STEP ANGLE ACCURACY
± 5%

INSULATION CLASS
B

AMBIENT TEMPERATURE
-20°C +50°C

TEMP. RISE
80°C MAX (RATED CURRENT, 2 PHASE ON)

INSULATION RESISTANCE
100 M OHM MIN. 500 VDC

DIELECTRIC STRENGTH
820 VAC FOR ONE MINUTE

SHAFT RADIAL PLAY
0,02 MAX (450 G LOAD)

SHAFT AXIAL PLAY
0,08 MAX. (450 G LOAD)

MAX RADIAL FORCE
220 N (20 MM FROM FRONT FLANGE)

MAX AXIAL FORCE
60 N

Connection

LEAD N°	COLOR	GAUGE	FUNCTION
1	ORANGE	UL3266 AWG20	PHASE A
2	ORANGE/WHITE	UL3266 AWG20	PHASE A-
3	BLACK/WHITE	UL3266 AWG20	PHASE C-
4	BLACK	UL3266 AWG20	PHASE C
5	RED	UL3266 AWG20	PHASE B
6	RED/WHITE	UL3266 AWG20	PHASE B-
7	YELLOW/WHITE	UL3266 AWG20	PHASE D-
8	YELLOW	UL3266 AWG20	PHASE D

Stepper MOTOR

86SH65 High Torque Hybrid

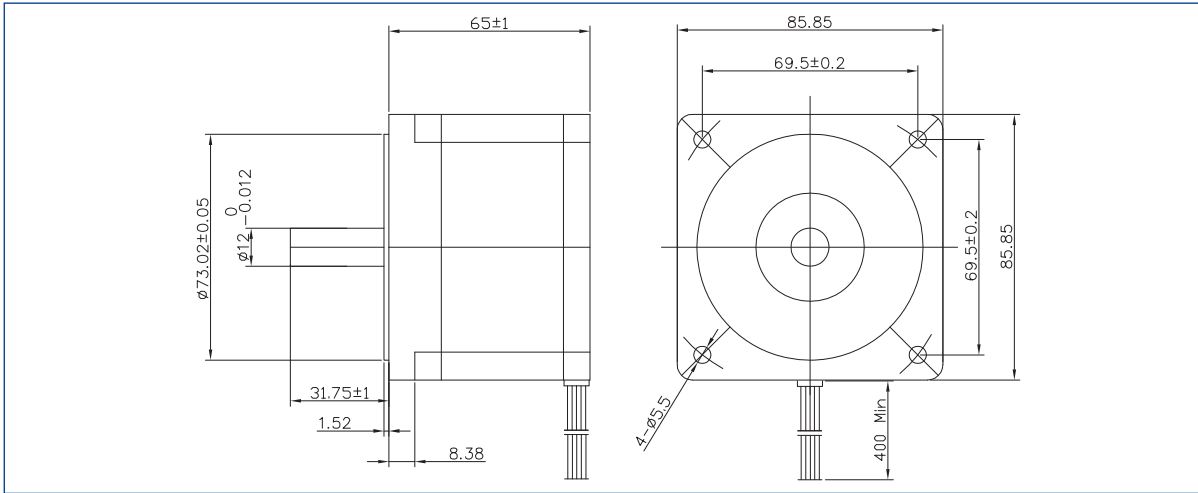

Characteristics

STEP ANGLE
1,8°

STEP ANGLE ACCURACY
± 5%

INSULATION CLASS
B

AMBIENT TEMPERATURE
-20°C +50°C

TEMP. RISE
80°C MAX (RATED CURRENT, 2 PHASE ON)

INSULATION RESISTANCE
100 M OHM MIN. 500 VDC

DIELECTRIC STRENGTH
820 VAC FOR ONE MINUTE

SHAFT RADIAL PLAY
0,02 MAX (450 G LOAD)

SHAFT AXIAL PLAY
0,08 MAX. (450 G LOAD)

MAX RADIAL FORCE
220 N (20 MM FROM FRONT FLANGE)

MAX AXIAL FORCE
60 N

Specification

Model		86SH65-4208A			
		UNIPOLAR	PARALLEL	SERIES	
1	RATED VOLTAGE	V	2,39	1,65	3,42
2	CURRENT/PHASE	A	4,2	5,9	3
3	RESISTANCE/PHASE	Ω	0,57	0,28	1,14
4	INDUCTANCE/PHASE	MH	1,7	1,7	6,8
5	HOLDING TORQUE	NM	2,6	3,4	3,4
6	ROTOR INERTIA	G-CM ²		1000	
7	WEIGHT	KG		1,7	
8	NUMBER OF LEADS	N°		8	
9	LENGTH	MM		65	

Connection

LEAD N°	COLOR	GAUGE	FUNCTION
1	RED	UL1430 AWG20	PHASE A
2	YELLOW	UL1430 AWG20	PHASE A-
3	BLUE	UL1430 AWG20	PHASE C-
4	BLACK	UL1430 AWG20	PHASE C
5	WHITE	UL1430 AWG20	PHASE B
6	ORANGE	UL1430 AWG20	PHASE B-
7	BROWN	UL1430 AWG20	PHASE D-
8	GREEN	UL1430 AWG20	PHASE D

Speed vs. Torque Characteristics

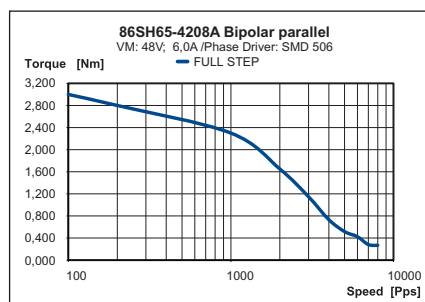

Stepper MOTOR

86SH80 High Torque Hybrid

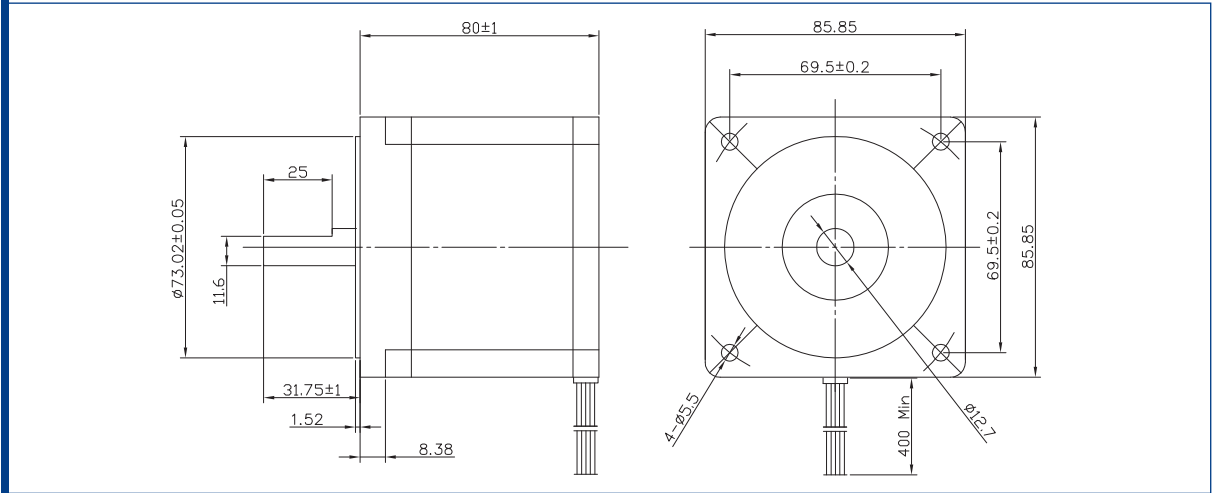

Specification

Model		86SH80-5504A	
1 RATED VOLTAGE	V	2,3	
2 CURRENT/PHASE	A	5,5	
3 RESISTANCE/PHASE	Ω	0,42	
4 INDUCTANCE/PHASE	mH	3,5	
5 HOLDING TORQUE	NM	4,6	
6 ROTOR INERTIA	g-cm ²	1400	
7 WEIGHT	KG	2,3	
8 NUMBER OF LEADS	N°	4	

Characteristics

STEP ANGLE	1,8°
STEP ANGLE ACCURACY	± 5%
INSULATION CLASS	B
AMBIENT TEMPERATURE	-20°C +50°C
TEMP. RISE	80°C MAX (RATED CURRENT, 2 PHASE ON)
INSULATION RESISTANCE	100 M OHM MIN. 500 VDC
DIELECTRIC STRENGTH	820 VAC FOR ONE MINUTE
SHAFT RADIAL PLAY	0,02 MAX (450 G LOAD)
SHAFT AXIAL PLAY	0,08 MAX. (450 G LOAD)
MAX RADIAL FORCE	220 N (20 MM FROM FRONT FLANGE)
MAX AXIAL FORCE	60 N

Speed vs. Torque Characteristics

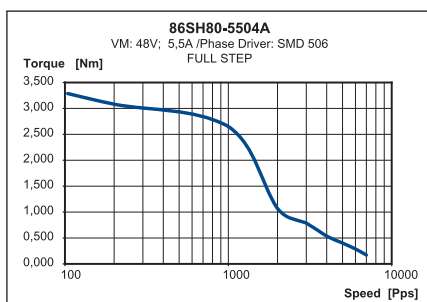

Connection

LEAD N°	COLOR	GAUGE	FUNCTION
1	RED	UL1430 AWG20	PHASE A
2	WHITE	UL1430 AWG20	PHASE A-
3	YELLOW	UL1430 AWG20	PHASE B
4	GREEN	UL1430 AWG20	PHASE B-

Stepper MOTOR

86SH96 High Torque Hybrid

86SH96 High Torque Hybrid

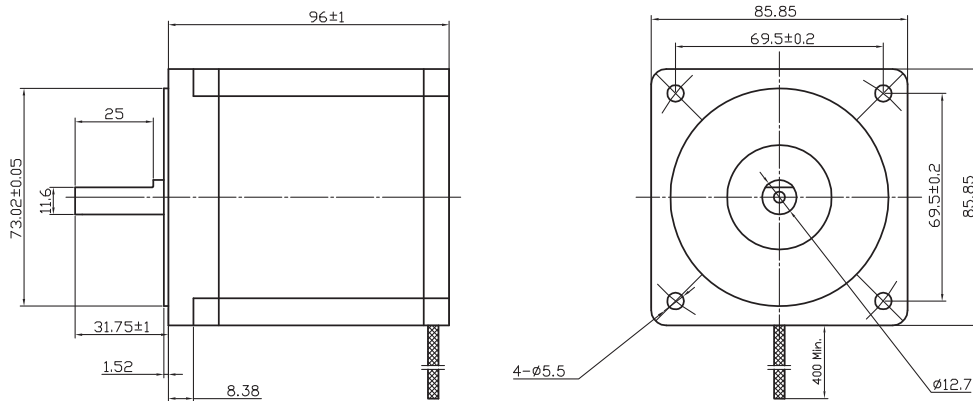

Characteristics

STEP ANGLE
1,8°

STEP ANGLE ACCURACY
± 5%

INSULATION CLASS
B

AMBIENT TEMPERATURE
-20°C +50°C

TEMP. RISE
80°C MAX (RATED CURRENT, 2 PHASE ON)

INSULATION RESISTANCE
100 M OHM MIN. 500 VDC

DIELECTRIC STRENGTH
820 VAC FOR ONE MINUTE

SHAFT RADIAL PLAY
0,02 MAX (450 G LOAD)

SHAFT AXIAL PLAY
0,08 MAX. (450 G LOAD)

MAX RADIAL FORCE
220 N (20 MM FROM FRONT FLANGE)

MAX AXIAL FORCE
60 N

Specification

Model	86SH96-5504A	
1 RATED VOLTAGE	V	2,56
2 CURRENT/PHASE	A	5,5
3 RESISTANCE/PHASE	Ω	0,465
4 INDUCTANCE/PHASE	mH	4,5
5 HOLDING TORQUE	Nm	7
6 ROTOR INERTIA	g-cm ²	1900
7 WEIGHT	Kg	2,8
8 NUMBER OF LEADS	N°	4

Connection

LEAD N°	COLOR	GAUGE	FUNCTION
1	RED	UL1430 AWG20	PHASE A
2	WHITE	UL1430 AWG20	PHASE A-
3	YELLOW	UL1430 AWG20	PHASE B
4	GREEN	UL1430 AWG20	PHASE B-

Speed vs. Torque Characteristics

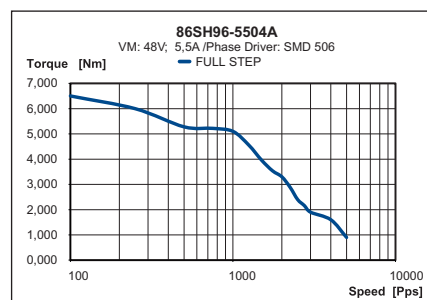

Stepper MOTOR

86SH118 High Torque Hybrid

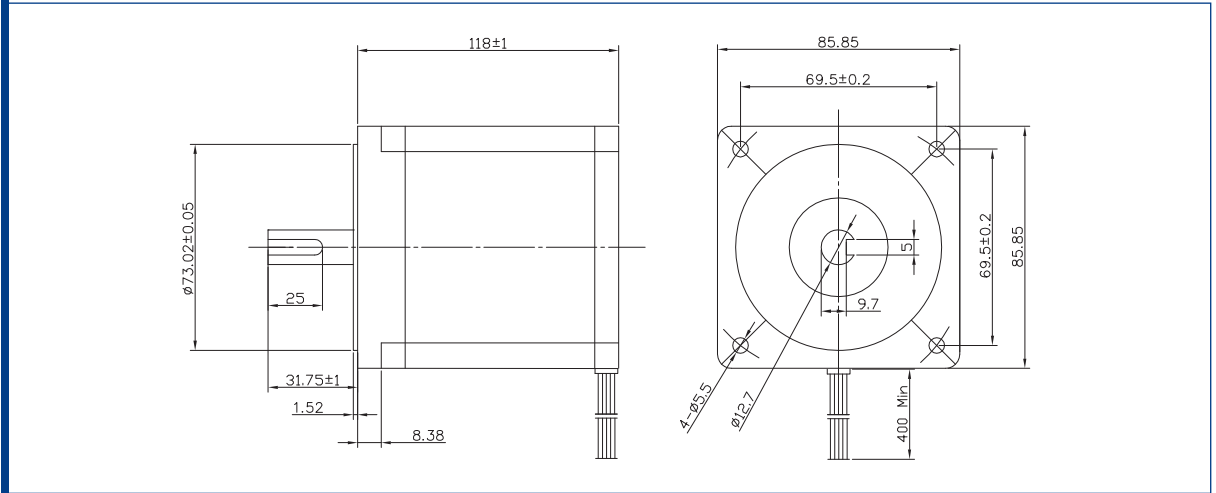

Specification

Model		86SH118-6004A	
1	RATED VOLTAGE	V	2,7
2	CURRENT/PHASE	A	6
3	RESISTANCE/PHASE	Ω	0,45
4	INDUCTANCE/PHASE	mH	5,1
5	HOLDING TORQUE	NM	8,7
6	ROTOR INERTIA	g-cm ²	2700
7	WEIGHT	KG	3,8
8	NUMBER OF LEADS	N°	4

Characteristics

STEP ANGLE	1,8°
STEP ANGLE ACCURACY	± 5%
INSULATION CLASS	B
AMBIENT TEMPERATURE	-20°C +50°C
TEMP. RISE	80°C MAX (RATED CURRENT, 2 PHASE ON)
INSULATION RESISTANCE	100 M OHM MIN. 500 VDC
DIELECTRIC STRENGTH	820 VAC FOR ONE MINUTE
SHAFT RADIAL PLAY	0,02 MAX (450 G LOAD)
SHAFT AXIAL PLAY	0,08 MAX. (450 G LOAD)
MAX RADIAL FORCE	220 N (20 MM FROM FRONT FLANGE)
MAX AXIAL FORCE	60 N

Speed vs. Torque Characteristics

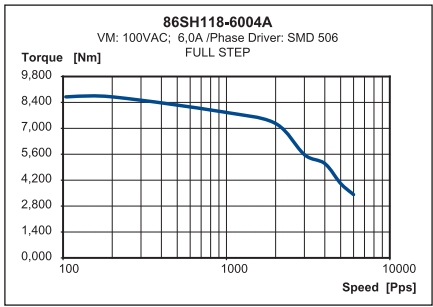

Connection

LEAD N°	COLOR	GAUGE	FUNCTION
1	RED	UL1430 AWG20	PHASE A
2	WHITE	UL1430 AWG20	PHASE A-
3	YELLOW	UL1430 AWG20	PHASE B
4	GREEN	UL1430 AWG20	PHASE B-



Stepper MOTOR

86SH156 High Torque Hybrid

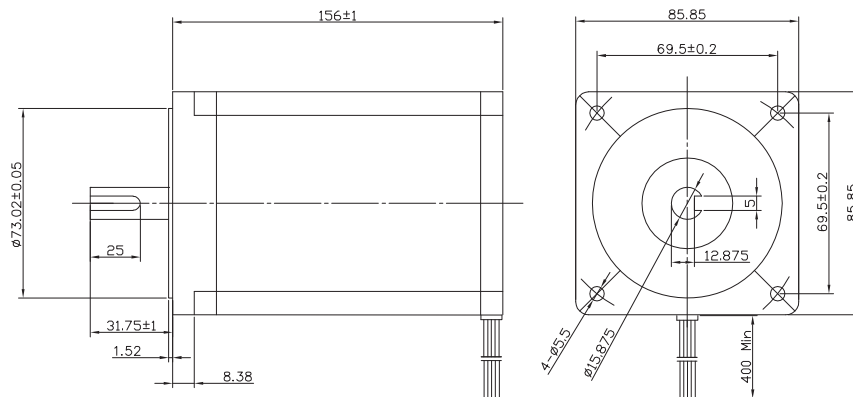

Characteristics

STEP ANGLE
1,8°

STEP ANGLE ACCURACY
± 5%

INSULATION CLASS
B

AMBIENT TEMPERATURE
-20°C +50°C

TEMP. RISE
80°C MAX (RATED CURRENT, 2 PHASE ON)

INSULATION RESISTANCE
100 M OHM MIN. 500 VDC

DIELECTRIC STRENGTH
820 VAC FOR ONE MINUTE

SHAFT RADIAL PLAY
0,02 MAX (450 G LOAD)

SHAFT AXIAL PLAY
0,08 MAX. (450 G LOAD)

MAX RADIAL FORCE
220 N (20 MM FROM FRONT FLANGE)

MAX AXIAL FORCE
60 N

Specification

Model	86SH156-6204A		
1 RATED VOLTAGE	V	3,5	
2 CURRENT/PHASE	A	6,2	
3 RESISTANCE/PHASE	Ω	0,75	
4 INDUCTANCE/PHASE	mH	9	
5 HOLDING TORQUE	Nm	12,8	
6 ROTOR INERTIA	g-cm ²	4000	
7 WEIGHT	Kg	5,4	
8 NUMBER OF LEADS	N°	4	

Connection

LEAD N°	COLOR	GAUGE	FUNCTION
1	RED	UL1430 AWG20	PHASE A
2	WHITE	UL1430 AWG20	PHASE A-
3	YELLOW	UL1430 AWG20	PHASE B
4	GREEN	UL1430 AWG20	PHASE B-

Speed vs. Torque Characteristics

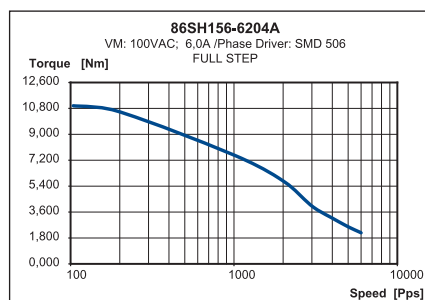

Stepper MOTOR

110SH99 High Torque Hybrid

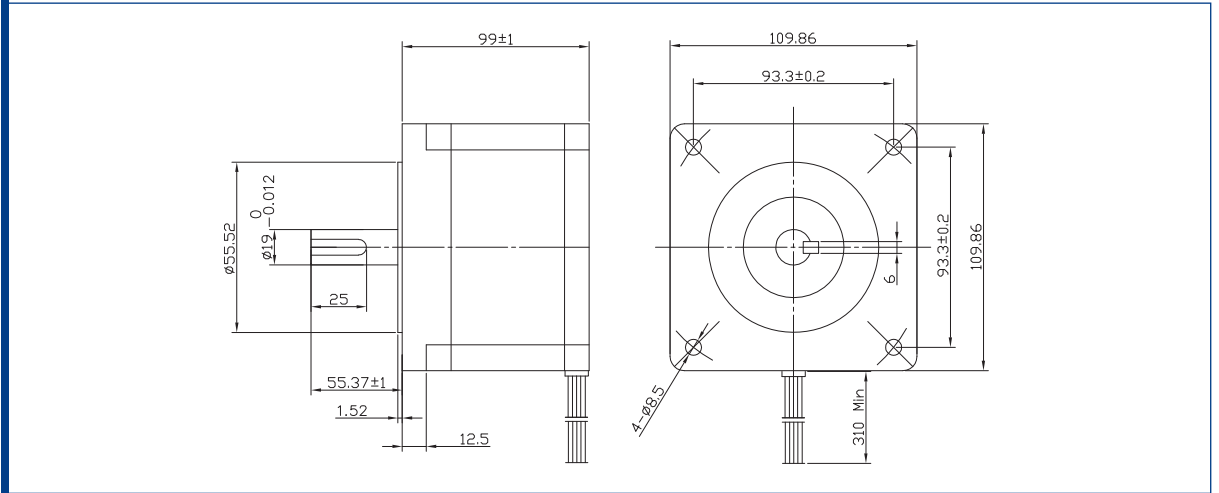

Specification

Model		110SH99-5504A	
1 RATED VOLTAGE	V	4,95	
2 CURRENT/PHASE	A	5,5	
3 RESISTANCE/PHASE	Ω	0,9	
4 INDUCTANCE/PHASE	mH	12	
5 HOLDING TORQUE	NM	11,2	
6 ROTOR INERTIA	g-CM ²	5500	
7 WEIGHT	KG	5	
8 NUMBER OF LEADS	N°	4	

Characteristics

STEP ANGLE
1,8°

STEP ANGLE ACCURACY
± 5%

INSULATION CLASS
B

AMBIENT TEMPERATURE
-20°C +50°C

TEMP. RISE
80°C MAX (RATED CURRENT, 2 PHASE ON)

INSULATION RESISTANCE
100 M OHM MIN. 500 VDC

DIELECTRIC STRENGTH
820 VAC FOR ONE MINUTE

SHAFT RADIAL PLAY
0,02 MAX (450 G LOAD)

SHAFT AXIAL PLAY
0,08 MAX. (450 G LOAD)

MAX RADIAL FORCE
220 N (20 MM FROM FRONT FLANGE)

MAX AXIAL FORCE
60 N

Speed vs. Torque Characteristics

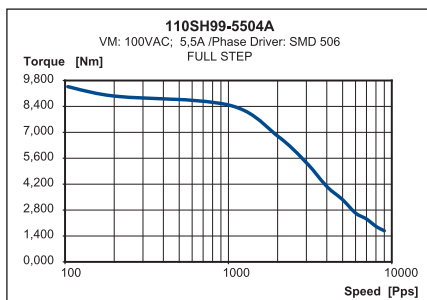

Connection

LEAD N°	COLOR	GAUGE	FUNCTION
1	RED	UL1430 AWG18	PHASE A
2	WHITE	UL1430 AWG18	PHASE A-
3	YELLOW	UL1430 AWG18	PHASE B
4	GREEN	UL1430 AWG18	PHASE B-

Stepper MOTOR

110SH150 High Torque Hybrid

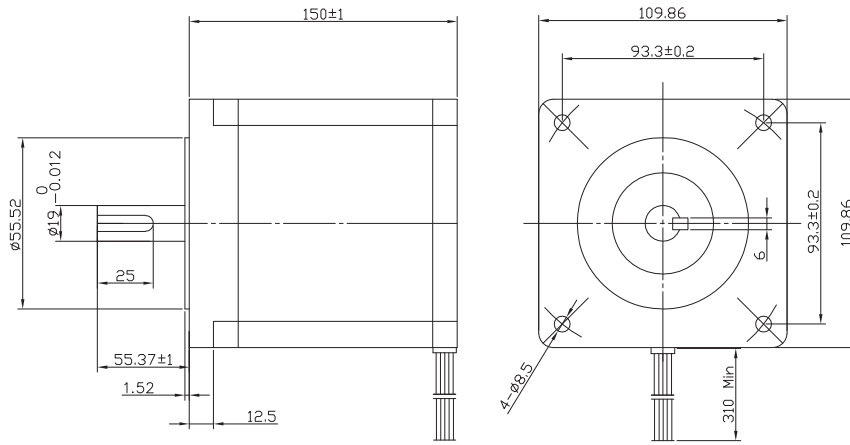

Characteristics

STEP ANGLE
1,8°

STEP ANGLE ACCURACY
± 5%

INSULATION CLASS
B

AMBIENT TEMPERATURE
-20°C +50°C

TEMP. RISE
80°C MAX (RATED CURRENT, 2 PHASE ON)

INSULATION RESISTANCE
100 M OHM MIN. 500 VDC

DIELECTRIC STRENGTH
820 VAC FOR ONE MINUTE

SHAFT RADIAL PLAY
0,02 MAX (450 G LOAD)

SHAFT AXIAL PLAY
0,08 MAX. (450 G LOAD)

MAX RADIAL FORCE
220 N (20 MM FROM FRONT FLANGE)

MAX AXIAL FORCE
60 N

Specification

Model	110SH150-6504A	
1 RATED VOLTAGE	V	5,2
2 CURRENT/PHASE	A	6,5
3 RESISTANCE/PHASE	Ω	0,8
4 INDUCTANCE/PHASE	mH	15
5 HOLDING TORQUE	NM	22
6 ROTOR INERTIA	G-CM ²	10900
7 WEIGHT	KG	8,4
8 NUMBER OF LEADS	N°	4

Connection

LEAD N°	COLOR	GAUGE	FUNCTION
1	RED	UL1430 AWG18	PHASE A
2	WHITE	UL1430 AWG18	PHASE A-
3	YELLOW	UL1430 AWG18	PHASE B
4	GREEN	UL1430 AWG18	PHASE B-

Speed vs. Torque Characteristics

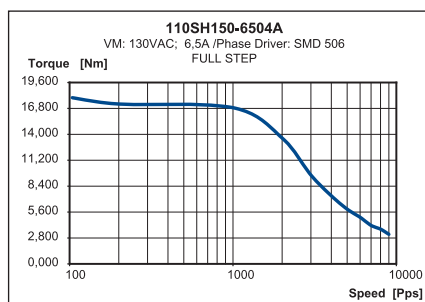

Stepper MOTOR

110SH201 High Torque Hybrid

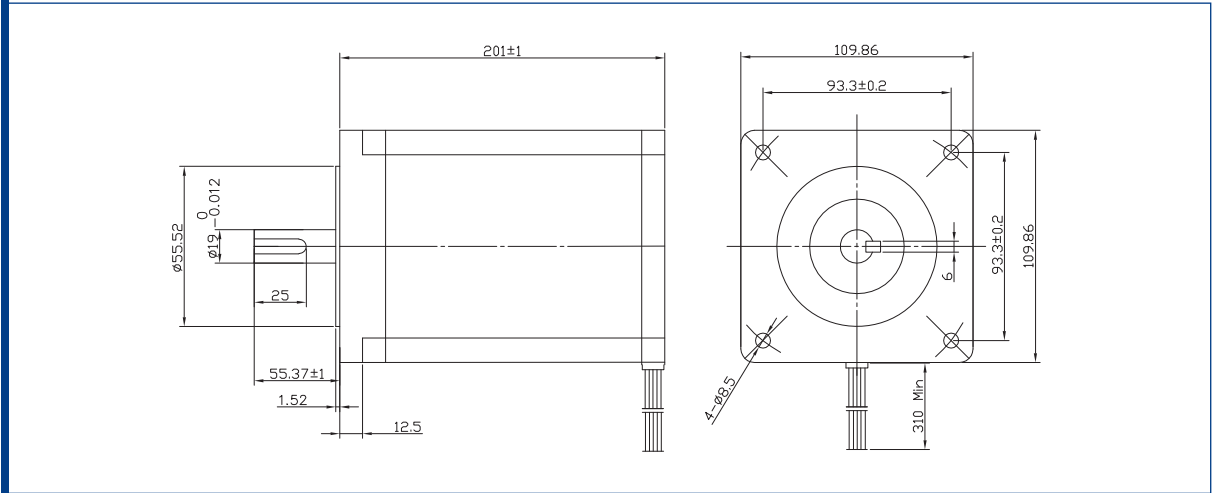

Specification

Model		110SH201-8004A	
1 RATED VOLTAGE	V	5,36	
2 CURRENT/PHASE	A	8	
3 RESISTANCE/PHASE	Ω	0,67	
4 INDUCTANCE/PHASE	mH	12	
5 HOLDING TORQUE	NM	30	
6 ROTOR INERTIA	g-cm ²	16200	
7 WEIGHT	KG	11,7	
8 NUMBER OF LEADS	N°	4	

Characteristics

STEP ANGLE	1,8°
STEP ANGLE ACCURACY	± 5%
INSULATION CLASS	B
AMBIENT TEMPERATURE	-20°C +50°C
TEMP. RISE	80°C MAX (RATED CURRENT, 2 PHASE ON)
INSULATION RESISTANCE	100 M OHM MIN. 500 VDC
DIELECTRIC STRENGTH	820 VAC FOR ONE MINUTE
SHAFT RADIAL PLAY	0,02 MAX (450 G LOAD)
SHAFT AXIAL PLAY	0,08 MAX. (450 G LOAD)
MAX RADIAL FORCE	220 N (20 MM FROM FRONT FLANGE)
MAX AXIAL FORCE	60 N

Speed vs. Torque Characteristics

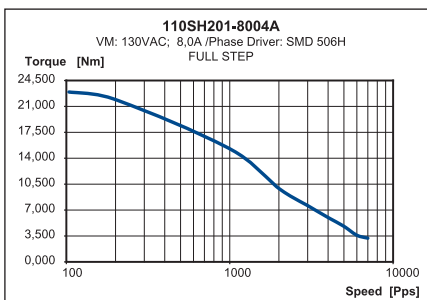

Connection

LEAD N°	COLOR	GAUGE	FUNCTION
1	RED	UL1430 AWG18	PHASE A
2	WHITE	UL1430 AWG18	PHASE A-
3	YELLOW	UL1430 AWG18	PHASE B
4	GREEN	UL1430 AWG18	PHASE B-

Stepper MOTOR

423P24 3Phase High Torque Hybrid

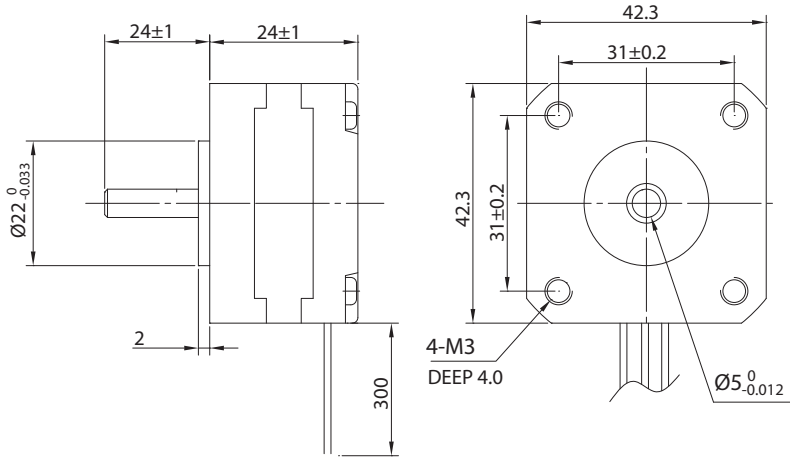

Characteristics

STEP ANGLE
1,2°

STEP ANGLE ACCURACY
± 5%

INSULATION CLASS
B

AMBIENT TEMPERATURE
-20°C +50°C

TEMP. RISE
80°C MAX (RATED CURRENT, 2 PHASE ON)

INSULATION RESISTANCE
100 M OHM MIN. 500 VDC

DIELECTRIC STRENGTH
500 VAC FOR ONE MINUTE

SHAFT RADIAL PLAY
0,02 MAX (450 G LOAD)

SHAFT AXIAL PLAY
0,08 MAX. (450 G LOAD)

MAX RADIAL FORCE
28 N (20 MM FROM FRONT FLANGE)

MAX AXIAL FORCE
10 N

Specification

Model	423P24-0903A	
1 RATED VOLTAGE	V	5,58
2 CURRENT/PHASE	A	0,9
3 RESISTANCE/PHASE	Ω	6,2
4 INDUCTANCE/PHASE	mH	3,2
5 HOLDING TORQUE	Nm	0,08
6 ROTOR INERTIA	g-cm ²	20
7 WEIGHT	Kg	0,14
8 NUMBER OF LEADS	N°	3

Connection

PIN N°	COLOR	GAUGE	FUNCTION
1	RED	UL1430 AWG26	PHASE U
2	YELLOW	UL1430 AWG26	PHASE V
3	BLUE	UL1430 AWG26	PHASE W

Speed vs. Torque Characteristics

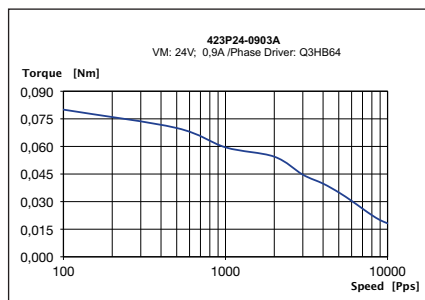

Stepper MOTOR

3Phase High Torque Hybrid 423P39

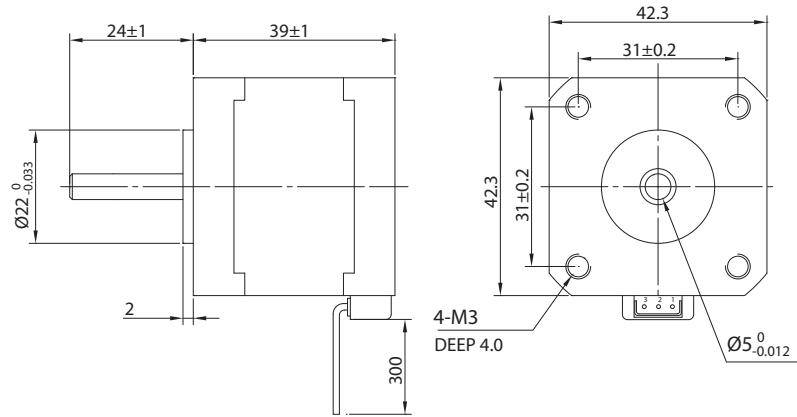

Specification

Model		423P39-2403A	
1	RATED VOLTAGE	V	2,88
2	CURRENT/PHASE	A	2,4
3	RESISTANCE/PHASE	Ω	1,2
4	INDUCTANCE/PHASE	mH	0,8
5	HOLDING TORQUE	Nm	0,2
6	ROTOR INERTIA	g-cm ²	54
7	WEIGHT	Kg	0,28
8	NUMBER OF LEADS	N°	3

Characteristics

STEP ANGLE	1,2°
STEP ANGLE ACCURACY	± 5%
INSULATION CLASS	B
AMBIENT TEMPERATURE	-20°C +50°C
TEMP. RISE	80°C MAX (RATED CURRENT, 2 PHASE ON)
INSULATION RESISTANCE	100 M OHM MIN. 500 VDC
DIELECTRIC STRENGTH	500 VAC FOR ONE MINUTE
SHAFT RADIAL PLAY	0,02 MAX (450 G LOAD)
SHAFT AXIAL PLAY	0,08 MAX. (450 G LOAD)
MAX RADIAL FORCE	28 N (20 MM FROM FRONT FLANGE)
MAX AXIAL FORCE	10 N

Speed vs. Torque Characteristics

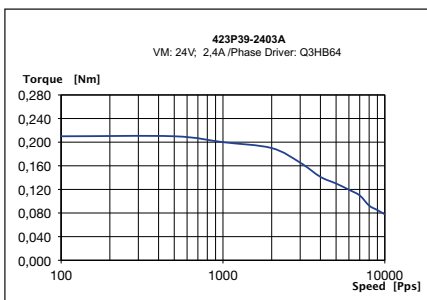

Connection

PIN N°	COLOR	GAUGE	FUNCTION
1	RED	UL1430 AWG26	PHASE U
2	YELLOW	UL1430 AWG26	PHASE V
3	BLUE	UL1430 AWG26	PHASE W

Stepper MOTOR

573P42 3Phase High Torque Hybrid

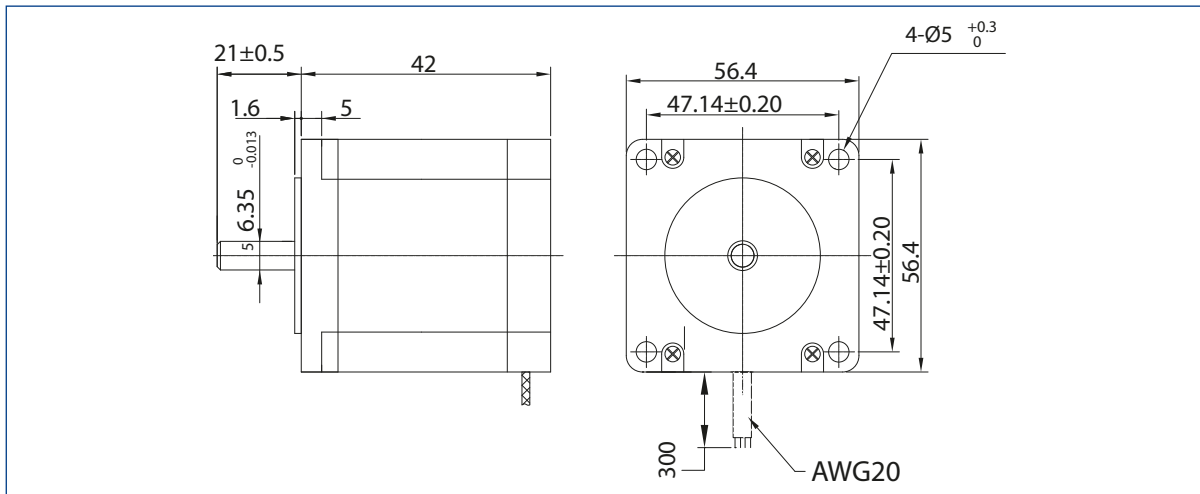

Characteristics

STEP ANGLE
1,2°

STEP ANGLE ACCURACY
± 5%

INSULATION CLASS
B

AMBIENT TEMPERATURE
-20°C +50°C

TEMP. RISE
80°C MAX (RATED CURRENT, 2 PHASE ON)

INSULATION RESISTANCE
100 M OHM MIN. 500 VDC

DIELECTRIC STRENGTH
500 VAC FOR ONE MINUTE

SHAFT RADIAL PLAY
0,02 MAX (450 G LOAD)

SHAFT AXIAL PLAY
0,08 MAX. (450 G LOAD)

MAX RADIAL FORCE
28 N (20 MM FROM FRONT FLANGE)

MAX AXIAL FORCE
10 N

Specification

Model	573P42	
1 RATED VOLTAGE	V	6,76
2 CURRENT/PHASE	A	5,2
3 RESISTANCE/PHASE	Ω	1,3
4 INDUCTANCE/PHASE	mH	1,4
5 HOLDING TORQUE	Nm	0,45
6 ROTOR INERTIA	g-cm ²	110
7 WEIGHT	Kg	0,45
8 NUMBER OF LEADS	N°	6

Connection

LEAD N°	COLOR	GAUGE	FUNCTION
1	RED	UL1430 AWG26	PHASE U
2	ORANGE	UL1430 AWG26	PHASE U
3	WHITE	UL1430 AWG26	PHASE V
4	BLUE	UL1430 AWG26	PHASE V
5	YELLOW	UL1430 AWG26	PHASE W
6	GREEN	UL1430 AWG26	PHASE W

Speed vs. Torque Characteristics

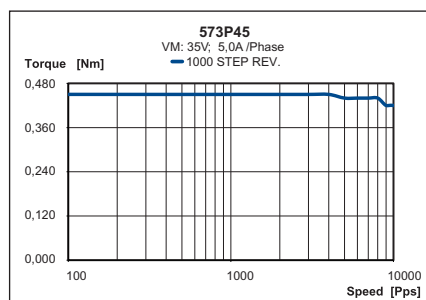

Stepper MOTOR

3Phase High Torque Hybrid 573P56

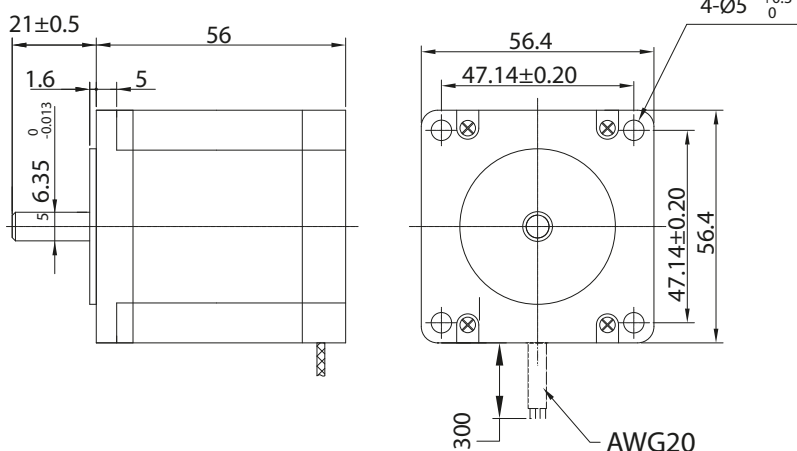

Specification

Model		573P56	
1 RATED VOLTAGE	V	4	
2 CURRENT/PHASE	A	5,6	
3 RESISTANCE/PHASE	Ω	0,7	
4 INDUCTANCE/PHASE	mH	1,7	
5 HOLDING TORQUE	NM	0,9	
6 ROTOR INERTIA	g-CM ²	300	
7 WEIGHT	KG	1	
8 NUMBER OF LEADS	N°	6	

Characteristics

STEP ANGLE	1,2°
STEP ANGLE ACCURACY	± 5%
INSULATION CLASS	B
AMBIENT TEMPERATURE	-20°C +50°C
TEMP. RISE	80°C MAX (RATED CURRENT, 2 PHASE ON)
INSULATION RESISTANCE	100 M OHM MIN. 500 VDC
DIELECTRIC STRENGTH	500 VAC FOR ONE MINUTE
SHAFT RADIAL PLAY	0,02 MAX (450 G LOAD)
SHAFT AXIAL PLAY	0,08 MAX. (450 G LOAD)
MAX RADIAL FORCE	28 N (20 MM FROM FRONT FLANGE)
MAX AXIAL FORCE	10 N

Speed vs. Torque Characteristics

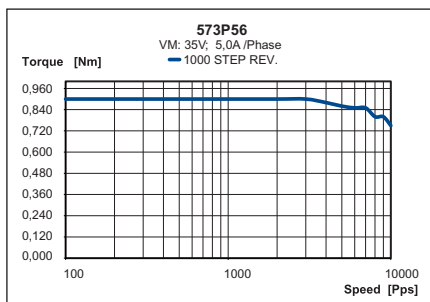

Connection

LEAD N°	COLOR	GAUGE	FUNCTION
1	RED	UL1430 AWG26	PHASE U
2	ORANGE	UL1430 AWG26	PHASE U
3	WHITE	UL1430 AWG26	PHASE V
4	BLUE	UL1430 AWG26	PHASE V
5	YELLOW	UL1430 AWG26	PHASE W
6	GREEN	UL1430 AWG26	PHASE W

Stepper MOTOR

573P79 3Phase High Torque Hybrid

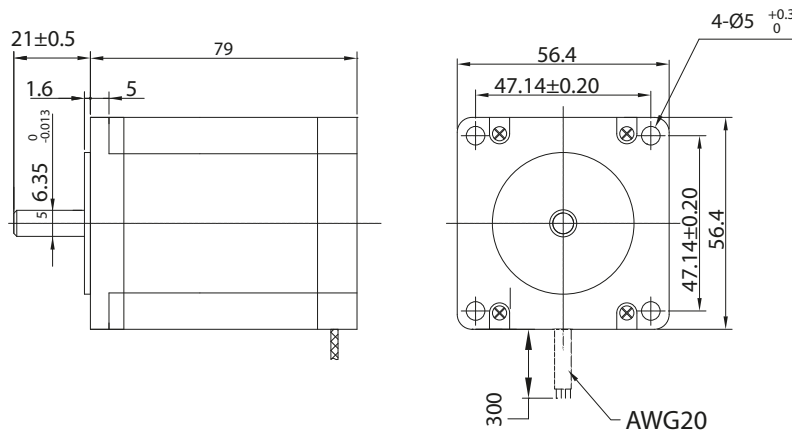

Characteristics

STEP ANGLE
1,2°

STEP ANGLE ACCURACY
± 5%

INSULATION CLASS
B

AMBIENT TEMPERATURE
-20°C +50°C

TEMP. RISE
80°C MAX (RATED CURRENT, 2 PHASE ON)

INSULATION RESISTANCE
100 M OHM MIN. 500 VDC

DIELECTRIC STRENGTH
500 VAC FOR ONE MINUTE

SHAFT RADIAL PLAY
0,02 MAX (450 G LOAD)

SHAFT AXIAL PLAY
0,08 MAX. (450 G LOAD)

MAX RADIAL FORCE
28 N (20 MM FROM FRONT FLANGE)

MAX AXIAL FORCE
10 N

Specification

Model	573P79	
1 RATED VOLTAGE	V	6
2 CURRENT/PHASE	A	5,8
3 RESISTANCE/PHASE	Ω	1,05
4 INDUCTANCE/PHASE	mH	2,4
5 HOLDING TORQUE	NM	1,5
6 ROTOR INERTIA	G-CM ²	480
7 WEIGHT	KG	1,2
8 NUMBER OF LEADS	N°	6

Connection

LEAD N°	COLOR	GAUGE	FUNCTION
1	RED	UL1430 AWG26	PHASE U
2	ORANGE	UL1430 AWG26	PHASE U
3	WHITE	UL1430 AWG26	PHASE V
4	BLUE	UL1430 AWG26	PHASE V
5	YELLOW	UL1430 AWG26	PHASE W
6	GREEN	UL1430 AWG26	PHASE W

Speed vs. Torque Characteristics

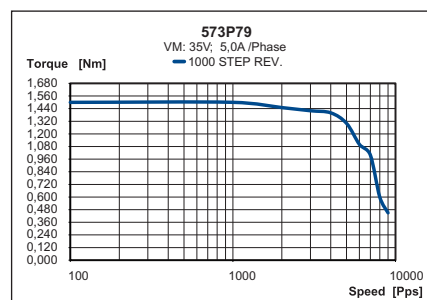

Fulling MOTOR



Production Final Test

- Insulation resistance:
500VDC, 100Mohm
- dielectric strength:
620VAC, 1 sec, 2mA
- Resistance/phase
- Inductance/phase
- Running torque
- Direction testing

Running Test

- Max. running speed
- Smooth running
- Noise and vibration

Appearance Testing

- Output shaft
- Lead wires
- Mounting dimension
(flange - screw - D-cut - etc)



Brushless MOTOR



Codification number

57	Size in mm.
BL	Motor type: BL= brushless
54	Motor lenght in mm.
xxx	Exec. Number - Special configuration

Quality Control Additional Test

- No load temperature rising

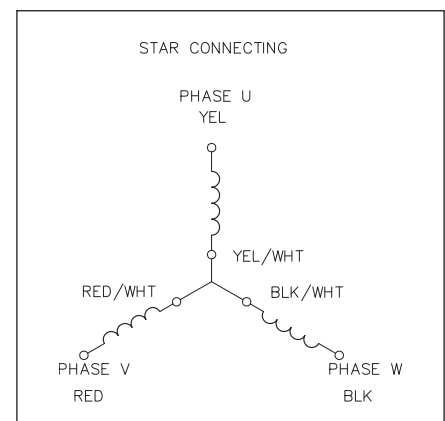
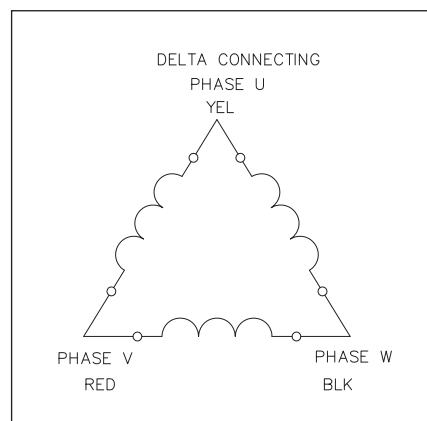

Brushless MOTOR

22BL

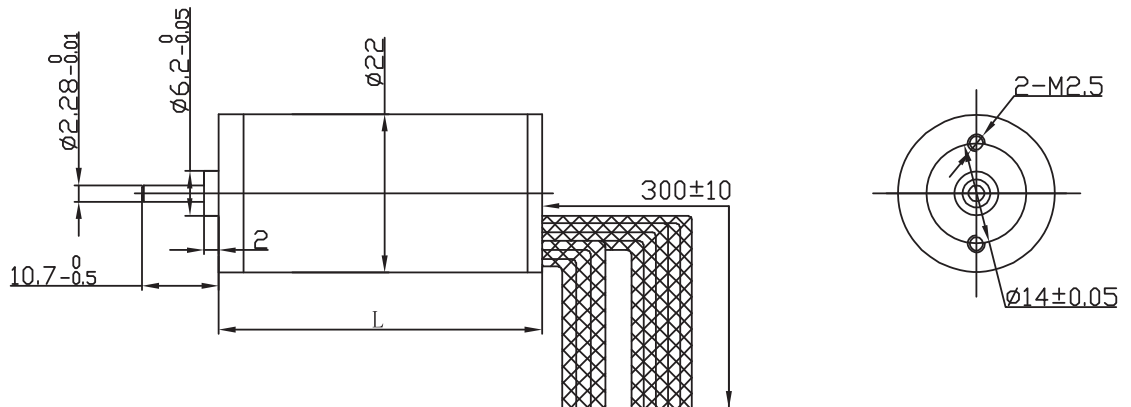

Specification

Model		22BL45	22BL70
1	N° OF POLE	8	8
2	N° OF PHASE	3	3
3	RATED VOLTAGE	V	24
4	RATED SPEED	RPM	4600
5	RATED TORQUE	NM	0,008
6	MAX PEAK TORQUE	NM	0,021
7	TORQUE CONSTANT	NM/A	0,030
8	LINE TO LINE RESISTANCE	Ω	23
9	LINE TO LINE INDUCTANCE	MH	6,2
10	MAX PEAK CURRENT	A	1,1
11	LENGTH	MM	45
12	ROTOR INERTIA	G-CM ²	0,66
13	WEIGHT	KG	0,07

Characteristics

HALL EFFECT ANGLE
120° ELECTRIC ANGLE

SHAFT RUN OUT
0,025 MM

INSULATION CLASS
B

RADIAL PLAY
0,02 MM (450 G LOAD)

AXIAL PLAY
0,08 MM (450 G LOAD)

MAX RADIAL FORCE
10N 10MM FROM FLANGE

MAX AXIAL FORCE
2N

DIELECTRIC STRENGTH
500 VDC FOR ONE MINUTE

INSULATION RESISTANCE
100 M OHM MIN. 500 VDC

Connection

LEAD N°	COLOR	GAUGE	FUNCTION
1	YELLOW	UL1430 AWG28	VCC HALL SENSOR +5 TO +24 Vdc
2	BLUE	UL1430 AWG28	HALL A
3	ORANGE	UL1430 AWG28	HALL B
4	BROWN	UL1430 AWG28	HALL C
5	WHITE	UL1430 AWG28	GND HALL SENSOR GROUND
6	GREEN	UL1430 AWG26	PHASE U
7	RED	UL1430 AWG26	PHASE V
8	BLACK	UL1430 AWG26	PHASE W

Brushless MOTOR

28BL

28BL

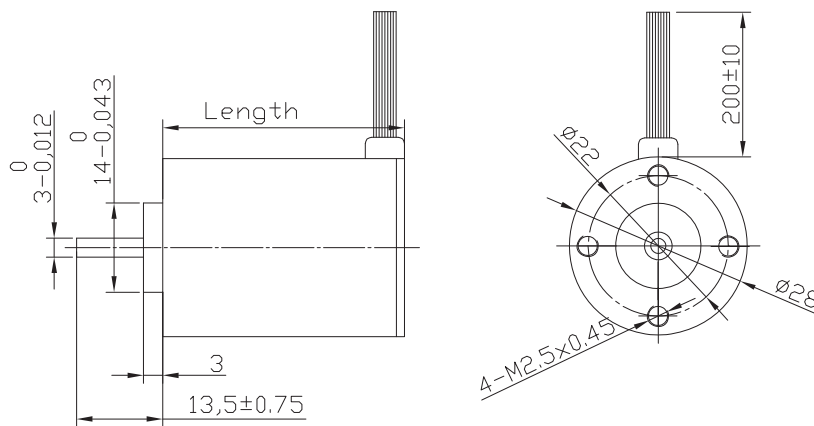

Characteristics

HALL EFFECT ANGLE
120 ° ELECTRIC ANGLE

SHAFT RUN OUT
0,025 MM

INSULATION CLASS
B

RADIAL PLAY
0,02 MM (450 G LOAD)

AXIAL PLAY
0,08 MM (450 G LOAD)

MAX RADIAL FORCE
15 N (10 MM FROM FLANGE)

MAX AXIAL FORCE
10 N

DIELECTRIC STRENGTH
500 VDC FOR ONE MINUTE

MAX AXIAL FORCE
100 M OHM MIN. 500 VDC

Specification

Model		28BL26	28BL38	28BL77	
1	N° OF POLE	4	4	4	
2	N° OF PHASE	3	3	3	
3	RATED VOLTAGE	V	15	24	24
4	RATED SPEED	RPM	8000	3100	3100
5	RATED TORQUE	NM	0,007	0,016	0,05
6	MAX PEAK TORQUE	NM	0,021	0,048	0,15
7	TORQUE CONSTANT	NM/A	0,013	0,024	0,05
8	LINE TO LINE RESISTANCE	Ω	7	20,5	4,67
9	LINE TO LINE INDUCTANCE	mH	2,5	7,4	2,2
10	MAX PEAK CURRENT	A	1,53	2	3
11	LENGTH	MM	26	38	77
12	ROTOR INERTIA	g·CM ²	1,23	2,12	5,98
13	WEIGHT	Kg	0,05	0,082	0,2

Connection

LEAD N°	COLOR	GAUGE	FUNCTION
1	YELLOW	UL1430 AWG26	Vcc HALL SENSOR
-	-	-	+5 TO +24 VDC
2	BLUE	UL1430 AWG26	HALL A
3	ORANGE	UL1430 AWG26	HALL B
4	BROWN	UL1430 AWG26	HALL C
5	WHITE	UL1430 AWG26	GND HALL SENSOR GROUND
6	GREEN	UL1430 AWG26	PHASE U
7	RED	UL1430 AWG26	PHASE V
8	BLACK	UL1430 AWG26	PHASE W



Brushless MOTOR

33BL



CE

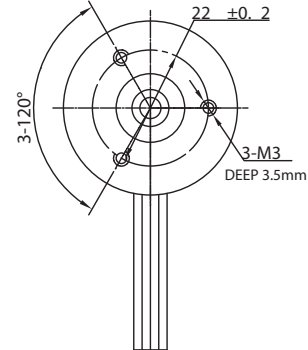
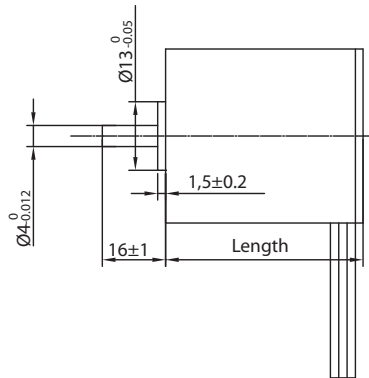

Specification

Model		33BL38	33BL80
1	N° OF POLE	4	4
2	N° OF PHASE	3	3
3	RATED VOLTAGE	V	24
4	RATED SPEED	RPM	4500
5	RATED TORQUE	NM	0,022
6	MAX PEAK TORQUE	NM	0,066
7	TORQUE CONSTANT	NM/A	0,046
8	LINE TO LINE RESISTANCE	Ω	14,2
9	LINE TO LINE INDUCTANCE	mH	7
10	MAX PEAK CURRENT	A	1,45
11	LENGTH	MM	38
12	ROTOR INERTIA	g-CM ²	2,94
13	WEIGHT	KG	0,115

Characteristics

HALL EFFECT ANGLE
120 ° ELECTRIC ANGLE

SHAFT RUN OUT
0,025 MM

INSULATION CLASS
B

RADIAL PLAY
0,02 MM (450 G LOAD)

AXIAL PLAY
0,08 MM (450 G LOAD)

MAX RADIAL FORCE
15N 10MM FROM FLANGE

MAX AXIAL FORCE
10N

DIELECTRIC STRENGTH
500 VDC FOR ONE MINUTE

INSULATION RESISTANCE
100 M OHM MIN. 500 VDC

Connection

LEAD N°	COLOR	GAUGE	FUNCTION
1	YELLOW	UL1430 AWG26	VCC HALL SENSOR +5 TO +24 Vdc
2	BLUE	UL1430 AWG26	HALL A
3	ORANGE	UL1430 AWG26	HALL B
4	BROWN	UL1430 AWG26	HALL C
5	WHITE	UL1430 AWG26	GND HALL SENSOR GROUND
6	GREEN	UL1430 AWG22	PHASE U
7	RED	UL1430 AWG22	PHASE V
8	BLACK	UL1430 AWG22	PHASE W

Brushless MOTOR

36BL57

36BL

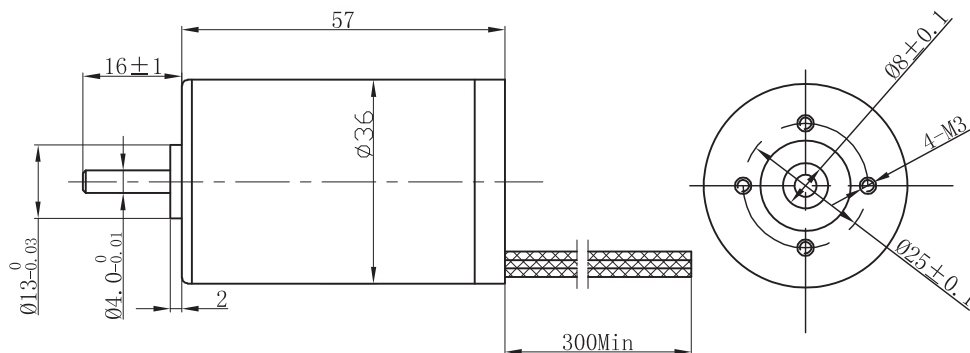

CE

Characteristics

HALL EFFECT ANGLE
120 ° ELECTRIC ANGLE

SHAFT RUN OUT
0,025 MM

INSULATION CLASS
B

RADIAL PLAY
0,02 MM (450 G LOAD)

AXIAL PLAY
0,08 MM (450 G LOAD)

MAX RADIAL FORCE
15N 10MM FROM FLANGE

MAX AXIAL FORCE
10N

DIELECTRIC STRENGTH
500 VDC FOR ONE MINUTE

INSULATION RESISTANCE
100 M OHM MIN. 500 VDC

Specification

Model	36BL57	
1 N° OF POLE		8
2 N° OF PHASE		3
3 RATED VOLTAGE	V	24
4 RATED SPEED	RPM	2600
5 RATED TORQUE	NM	0,04
6 MAX PEAK TORQUE	NM	0,12
7 TORQUE CONSTANT	NM/A	0,07
8 LINE TO LINE RESISTANCE	Ω	5,4
9 LINE TO LINE INDUCTANCE	mH	6,4
10 MAX PEAK CURRENT	A	1,7
11 LENGTH	MM	57
12 ROTOR INERTIA	g-cm ²	21
13 WEIGHT	Kg	0,3

Connection

LEAD N°	COLOR	GAUGE	FUNCTION
1	YELLOW	UL1430 AWG26	VCC HALL SENSOR +5 TO +24 Vdc
2	BLUE	UL1430 AWG26	HALL A
3	ORANGE	UL1430 AWG26	HALL B
4	BROWN	UL1430 AWG26	HALL C
5	WHITE	UL1430 AWG26	GND HALL GROUND
6	GREEN	UL1430 AWG22	PHASE U
7	RED	UL1430 AWG22	PHASE V
8	BLACK	UL1430 AWG22	PHASE W



Brushless MOTOR

42BL

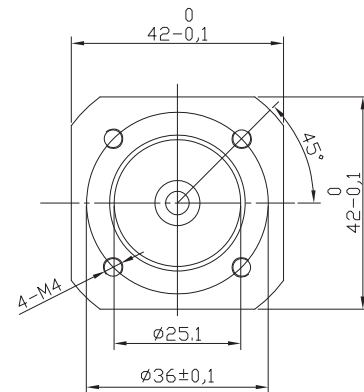
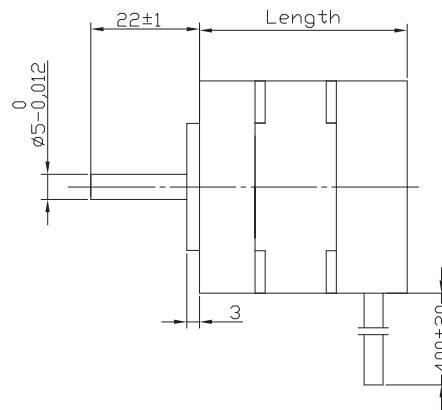

Specification

Model		42BL41	42BL61	42BL81	42BL100	
1	N° OF POLE	8	8	8	8	
2	N° OF PHASE	3	3	3	3	
3	RATED VOLTAGE	V	24	24	24	
4	RATED SPEED	RPM	4000	4000	4000	
5	RATED TORQUE	NM	0,0625	0,125	0,185	0,25
6	MAX PEAK TORQUE	NM	0,19	0,38	0,56	0,75
7	TORQUE CONSTANT	NM/A	0,035	0,036	0,036	0,036
8	LINE TO LINE RESISTANCE	Ω	1,8	0,72	0,55	0,28
9	LINE TO LINE INDUCTANCE	mH	2,6	1,2	0,8	0,54
10	MAX PEAK CURRENT	A	5,4	10,6	15,5	20
11	LENGTH	MM	41	61	81	100
12	ROTOR INERTIA	G-CM ²	24	48	72	96
13	WEIGHT	KG	0,3	0,45	0,65	0,8

Characteristics

HALL EFFECT ANGLE
120° ELECTRIC ANGLE

SHAFT RUN OUT
0,025 MM

INSULATION CLASS
B

RADIAL PLAY
0,02 MM (450 G LOAD)

AXIAL PLAY
0,08 MM (450 G LOAD)

MAX RADIAL FORCE
28 N (10 MM FROM FLANGE)

MAX AXIAL FORCE
10 N

DIELECTRIC STRENGTH
500 VDC FOR ONE MINUTE

MAX AXIAL FORCE
100 M OHM MIN. 500 VDC

Connection

LEAD N°	COLOR	GAUGE	FUNCTION
1	RED	UL1430 AWG26	VCC HALL SENSOR
-	-	-	+5 TO +24 VDC
2	BLUE	UL1430 AWG26	HALL A
3	GREEN	UL1430 AWG26	HALL B
4	WHITE	UL1430 AWG26	HALL C
5	BLACK	UL1430 AWG26	GND HALL
			SENSOR GROUND
6	YELLOW	UL1430 AWG20	PHASE U
7	RED	UL1430 AWG20	PHASE V
8	BLACK	UL1430 AWG20	PHASE W

Brushless MOTOR

42BLH

42BLH

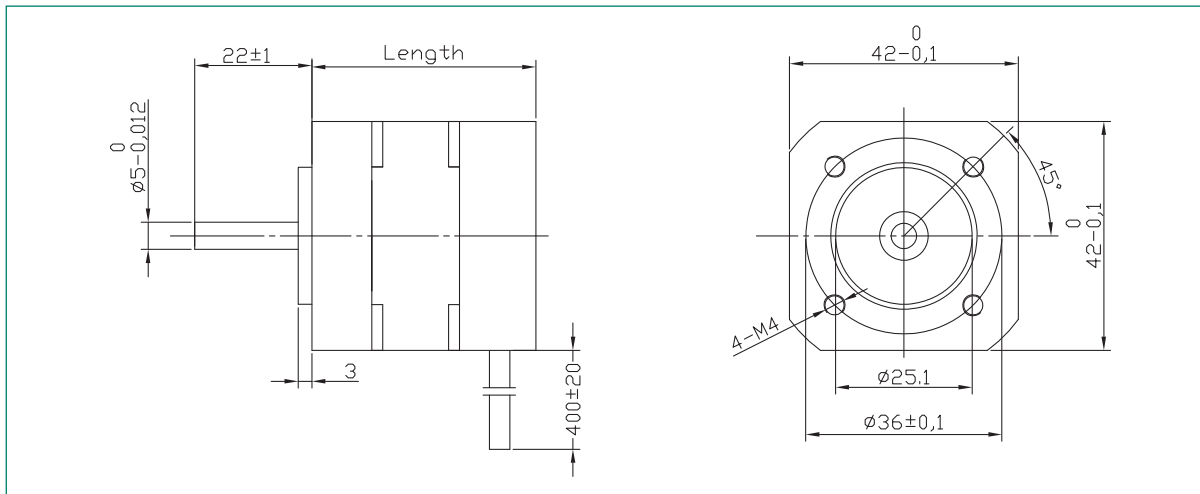

Characteristics

HALL EFFECT ANGLE
120° ELECTRIC ANGLE

SHAFT RUN OUT
0,025 MM

INSULATION CLASS
B

RADIAL PLAY
0,02 MM (450 G LOAD)

AXIAL PLAY
0,08 MM (450 G LOAD)

MAX RADIAL FORCE
28N 10MM FROM FLANGE

MAX AXIAL FORCE
10N

DIELECTRIC STRENGTH
500 VDC FOR ONE MINUTE

INSULATION RESISTANCE
100 M OHM MIN. 500 VDC

Specification

Model		42BLH01	42BLH02	42BLH03	42BLH04
1	N° OF POLE	10	10	10	10
2	N° OF PHASE	3	3	3	3
3	RATED VOLTAGE	V	24	24	24
4	RATED SPEED	RPM	3000	3000	3000
5	RATED TORQUE	NM	0,07	0,16	0,26
6	MAX PEAK TORQUE	NM	0,3	0,65	1,1
7	TORQUE CONSTANT	NM/A	0,054	0,054	0,054
8	LINE TO LINE RESISTANCE	Ω	2,6	1,1	0,7
9	LINE TO LINE INDUCTANCE	MH	1,83	0,96	0,58
10	MAX PEAK CURRENT	A	6,2	11,8	16,8
11	LENGTH	MM	40,3	60,3	80,3
12	ROTOR INERTIA	G-CM ²	48	101	154
13	WEIGHT	Kg	0,3	0,45	0,65

Connection

LEAD N°	COLOR	GAUGE	FUNCTION
1	RED	UL1430 AWG26	VCC HALL SENSOR +5 TO +24 Vdc
2	BLUE	UL1430 AWG26	HALL A
3	GREEN	UL1430 AWG26	HALL B
4	WHITE	UL1430 AWG26	HALL C
5	BLACK	UL1430 AWG26	GND HALL SENSOR GROUND
6	YELLOW	UL1430 AWG20	PHASE U
7	RED	UL1430 AWG20	PHASE V
8	BLACK	UL1430 AWG20	PHASE W

Brushless MOTOR

42RBL

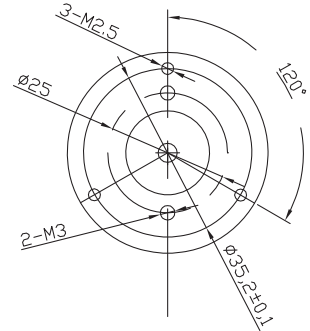
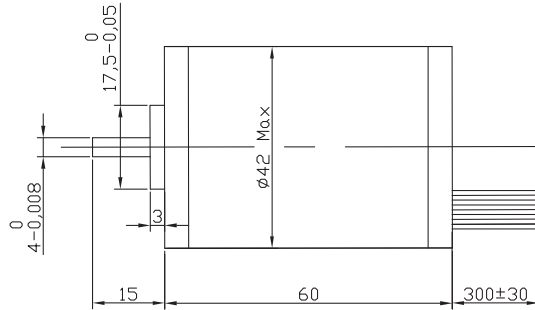

Specification

Model		42RBL60	42RBL85
1	N° OF POLE	8	8
2	N° OF PHASE	3	3
3	RATED VOLTAGE	V	24
4	RATED SPEED	RPM	4000
5	RATED TORQUE	NM	0,08
6	MAX PEAK TORQUE	NM	0,24
7	TORQUE CONSTANT	NM/A	0,038
8	LINE TO LINE RESISTANCE	Ω	1,6
9	LINE TO LINE INDUCTANCE	MH	1,94
10	MAX PEAK CURRENT	A	5
11	LENGTH	MM	60
12	ROTOR INERTIA	G-CM ²	48
13	WEIGHT	KG	0,4

Characteristics

HALL EFFECT ANGLE
120° ELECTRIC ANGLE

SHAFT RUN OUT
0,025 MM

INSULATION CLASS
B

RADIAL PLAY
0,02 MM (450 G LOAD)

AXIAL PLAY
0,08 MM (450 G LOAD)

MAX RADIAL FORCE
15N 10MM FROM FLANGE

MAX AXIAL FORCE
10N

DIELECTRIC STRENGTH
500 VDC FOR ONE MINUTE

INSULATION RESISTANCE
100 M OHM MIN. 500 VDC

Connection

LEAD N°	COLOR	GAUGE	FUNCTION
1	YELLOW	UL1430 AWG26	Vcc HALL SENSOR +5 TO +24 Vdc
2	BLUE	UL1430 AWG26	HALL A
3	ORANGE	UL1430 AWG26	HALL B
4	BROWN	UL1430 AWG26	HALL C
5	WHITE	UL1430 AWG26	GND HALL SENSOR GROUND
6	GREEN	UL1430 AWG22	PHASE U
7	RED	UL1430 AWG22	PHASE V
8	BLACK	UL1430 AWG22	PHASE W

Brushless MOTOR

45BLW18

45BLW18

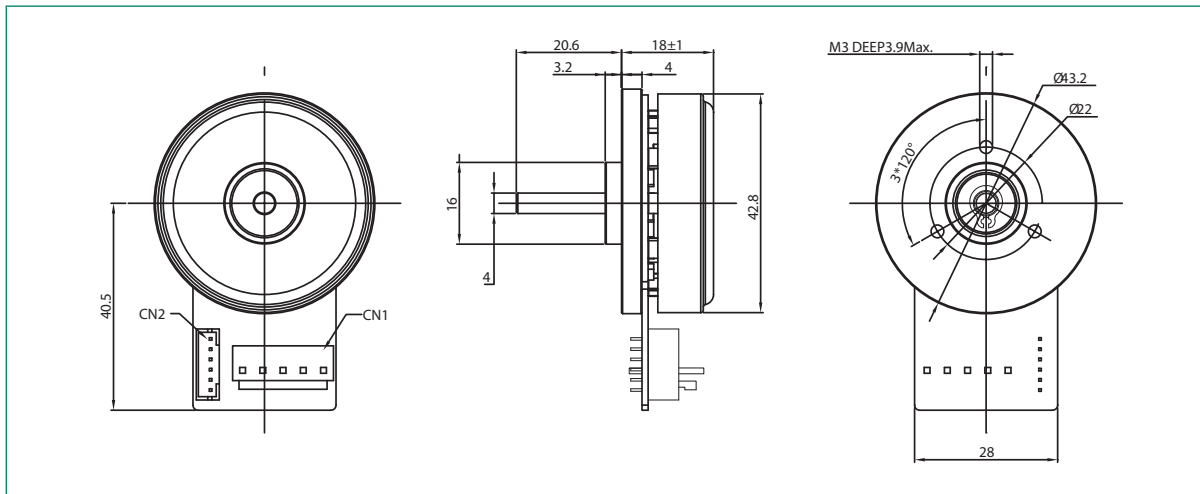

Characteristics

HALL EFFECT ANGLE
120 ° ELECTRIC ANGLE

SHAFT RUN OUT
0,03 MM

INSULATION CLASS
B

RADIAL PLAY
0,02 MM (450 G LOAD)

AXIAL PLAY
0,08 MM (450 G LOAD)

MAX RADIAL FORCE
28N 10MM FROM FLANGE

MAX AXIAL FORCE
10N

DIELECTRIC STRENGTH
500 VDC FOR ONE MINUTE

INSULATION RESISTANCE
100 M OHM MIN. 500 VDC

Specification

Model	45BLW18	
1	N° OF POLE	16
2	N° OF PHASE	3
3	RATED VOLTAGE V	24
4	RATED SPEED RPM	5000
5	RATED TORQUE NM	0,05
6	MAX PEAK TORQUE NM	0,15
7	TORQUE CONSTANT NM/A	0,031
8	LINE TO LINE RESISTANCE Ω	1,83
9	LINE TO LINE INDUCTANCE MH	0,74
10	MAX PEAK CURRENT A	4,8
11	LENGTH MM	18
12	ROTOR INERTIA G-CM ²	99
13	WEIGHT KG	0,08

Connection

PIN N°	CONNECTOR	FUNCTION
1	JST B5P	GND
2	JST B5P	PHASE U
3	JST B5P	PHASE V
4	JST B5P	PHASE W
5	JST B5P	GND
1	JST B6B	GND
2	JST B6B	+. 5V DC
3	JST B6B	HALL A
4	JST B6B	HALL B
5	JST B6B	HALL C
6	JST B6B	GND

Brushless MOTOR

45BLW21

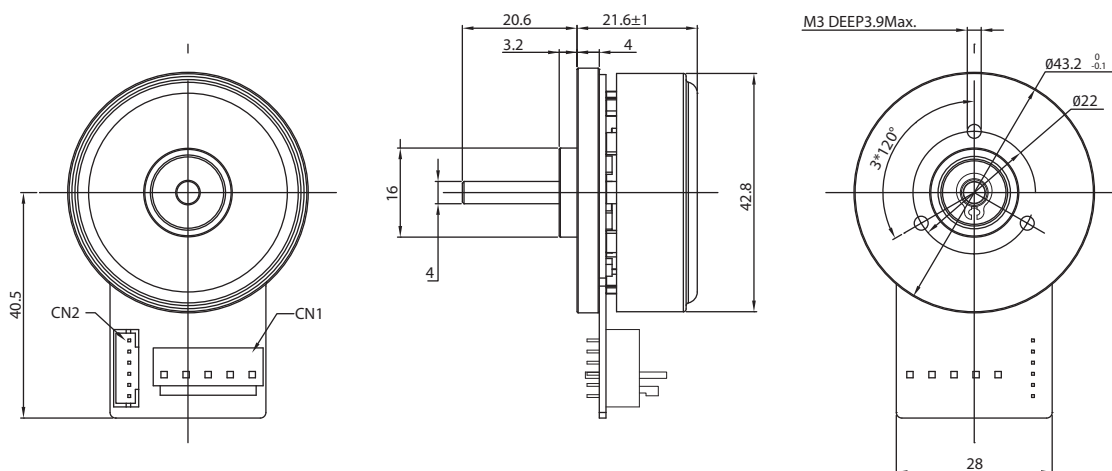

Specification

Model	45BLW21	
1 N° OF POLE		16
2 N° OF PHASE		3
3 RATED VOLTAGE	V	24
4 RATED SPEED	RPM	5260
5 RATED TORQUE	NM	0,084
6 MAX PEAK TORQUE	NM	0,25
7 TORQUE CONSTANT	NM/A	0,033
8 LINE TO LINE RESISTANCE	Ω	0,9
9 LINE TO LINE INDUCTANCE	MH	0,425
10 MAX PEAK CURRENT	A	7
11 LENGTH	MM	21
12 ROTOR INERTIA	G-CM ²	135
13 WEIGHT	KG	0,12

Characteristics

HALL EFFECT ANGLE
120 ° ELECTRIC ANGLE

SHAFT RUN OUT
0,03 MM

INSULATION CLASS
B

RADIAL PLAY
0,02 MM (450 G LOAD)

AXIAL PLAY
0,08 MM (450 G LOAD)

MAX RADIAL FORCE
28N 10MM FROM FLANGE

MAX AXIAL FORCE
10N

DIELECTRIC STRENGTH
500 VDC FOR ONE MINUTE

INSULATION RESISTANCE
100 M OHM MIN. 500 VDC

Connection

PIN N°	CONNECTOR	FUNCTION
1	JST B5P	GND
2	JST B5P	PHASE U
3	JST B5P	PHASE V
4	JST B5P	PHASE W
5	JST B5P	GND
1	JST B6B	GND
2	JST B6B	.+ 5V DC
3	JST B6B	HALL A
4	JST B6B	HALL B
5	JST B6B	HALL C
6	JST B6B	GND

Brushless MOTOR

45BLW27

45BLW27

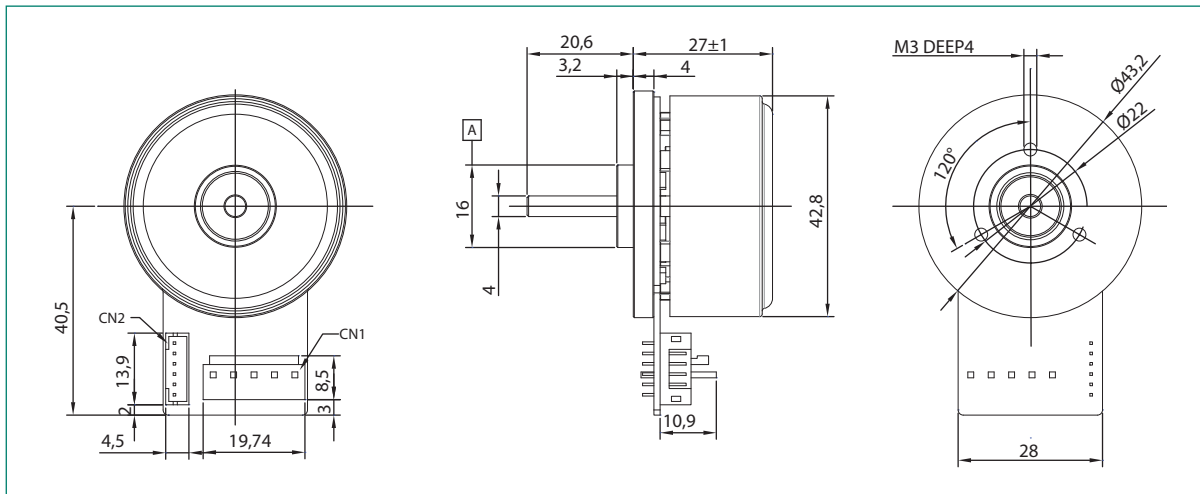

Characteristics

HALL EFFECT ANGLE
120 ° ELECTRIC ANGLE

SHAFT RUN OUT
0,03 MM

INSULATION CLASS
B

RADIAL PLAY
0,02 MM (450 G LOAD)

AXIAL PLAY
0,08 MM (450 G LOAD)

MAX RADIAL FORCE
28N 10MM FROM FLANGE

MAX AXIAL FORCE
10N

DIELECTRIC STRENGTH
500 VDC FOR ONE MINUTE

INSULATION RESISTANCE
100 M OHM MIN. 500 VDC

Specification

Model	45BLW27	
1	N° OF POLE	16
2	N° OF PHASE	3
3	RATED VOLTAGE	V 24
4	RATED SPEED	RPM 4840
5	RATED TORQUE	NM 0,13
6	MAX PEAK TORQUE	NM 0,36
7	TORQUE CONSTANT	NM/A 0,037
8	LINE TO LINE RESISTANCE	Ω 0,61
9	LINE TO LINE INDUCTANCE	mH 0,47
10	MAX PEAK CURRENT	A 10
11	LENGTH	MM 27
12	ROTOR INERTIA	g-cm ² 180
13	WEIGHT	KG 0,15

Connection

PIN N°	CONNECTOR	FUNCTION
1	JST B5P	GND
2	JST B5P	PHASE 1
3	JST B5P	PHASE 2
4	JST B5P	PHASE 3
5	JST B5P	GDN
1	JST B6B	GDN
2	JST B6B	+ 5V DC
3	JST B6B	HALL A
4	JST B6B	HALL B
5	JST B6B	HALL C
6	JST B6B	GND

Brushless MOTOR

57BL



CE

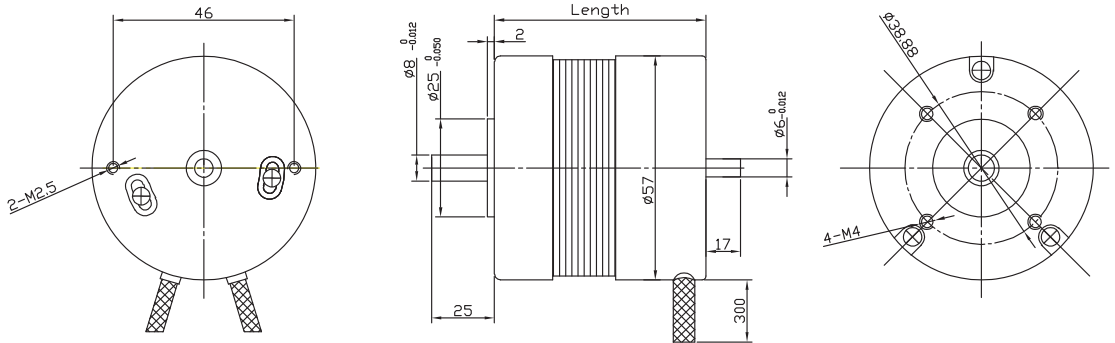

Specification

Model		57BL45	57BL54	57BL74	57BL94	57BL116
1	N° OF POLE	4	4	4	4	4
2	N° OF PHASE	3	3	3	3	3
3	RATED VOLTAGE	V	36	36	36	36
4	RATED SPEED	RPM	4000	4000	4000	4000
5	RATED TORQUE	NM	0,055	0,11	0,22	0,32
6	MAX PEAK TORQUE	NM	0,16	0,35	0,68	0,98
7	TORQUE CONSTANT	NM/A	0,053	0,063	0,063	0,063
8	LINE TO LINE RESISTANCE	Ω	4,1	1,5	0,65	0,45
9	LINE TO LINE INDUCTANCE	mH	10	4,5	2,1	1,4
10	MAX PEAK CURRENT	A	3,5	5,5	9,8	16,5
11	LENGTH	MM	45	54	74	94
12	ROTOR INERTIA	g-CM ²	30	75	119	173
13	WEIGHT	KG	0,25	0,5	0,75	1

Characteristics

HALL EFFECT ANGLE
120° ELECTRIC ANGLE

SHAFT RUN OUT
0,025 MM

INSULATION CLASS
B

RADIAL PLAY
0,02 MM (450 G LOAD)

AXIAL PLAY
0,08 MM (450 G LOAD)

MAX RADIAL FORCE
75 N (10 MM FROM FLANGE)

MAX AXIAL FORCE
15 N

DIELECTRIC STRENGTH
500 VDC FOR ONE MINUTE

INSULATION RESISTANCE
100 M OHM MIN. 500 VDC

Connection

LEAD N°	COLOR	GAUGE	FUNCTION
1	RED	UL1430 AWG26	VCC HALL SENSOR
-	-	-	+5 TO +24 VDC
2	BLUE	UL1430 AWG26	HALL A
3	GREEN	UL1430 AWG26	HALL B
4	WHITE	UL1430 AWG26	HALL C
5	BLACK	UL1430 AWG26	GND HALL
			SENSOR GROUND
6	YELLOW	UL1430 AWG20	PHASE U
7	RED	UL1430 AWG20	PHASE V
8	BLACK	UL1430 AWG20	PHASE W

Brushless MOTOR

57HBL

57HBL

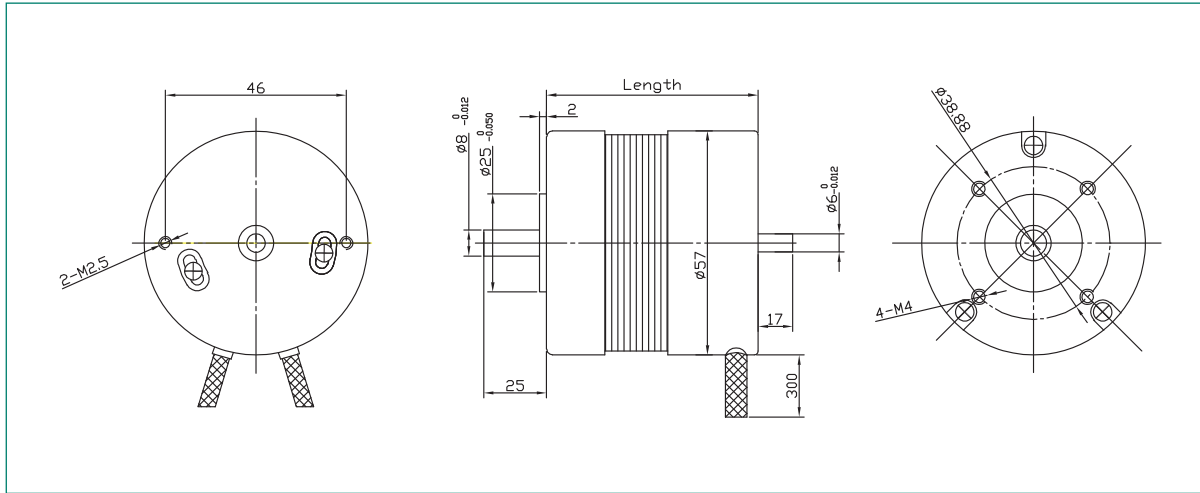

Characteristics

HALL EFFECT ANGLE
120 ° ELECTRIC ANGLE

SHAFT RUN OUT
0,025 MM

INSULATION CLASS
B

RADIAL PLAY
0,02 MM (450 G LOAD)

AXIAL PLAY
0,08 MM (450 G LOAD)

MAX RADIAL FORCE
75 N (10 MM FROM FLANGE)

MAX AXIAL FORCE
15 N

DIELECTRIC STRENGTH
500 VDC FOR ONE MINUTE

INSULATION RESISTANCE
100 M OHM MIN. 500 VDC

Specification

Model		57HBL54	57HBL69	57HBL74	57HBL94
1	N° OF POLE	6	6	6	6
2	N° OF PHASE	3	3	3	3
3	RATED VOLTAGE	V	24	24	24
4	RATED SPEED	RPM	3500	3500	3500
5	RATED TORQUE	NM	0,23	0,37	0,47
6	MAX PEAK TORQUE	NM	0,69	1,11	1,41
7	TORQUE CONSTANT	NM/A	0,045	0,046	0,05
8	LINE TO LINE RESISTANCE	Ω	0,57	0,24	0,22
9	LINE TO LINE INDUCTANCE	MH	0,63	0,29	0,29
10	MAX PEAK CURRENT	A	15	24	28
11	LENGTH	MM	53,6	68,6	73,6
12	ROTOR INERTIA	G-CM ²	75	105	119
13	WEIGHT	Kg	0,52	0,65	0,75

Connection

LEAD N°	COLOR	GAUGE	FUNCTION
1	RED	UL1332 AWG22	VCC HALL SENSOR
-	-	-	+5 TO +24 VDC
2	BLUE	UL1332 AWG22	HALL A
3	GREEN	UL1332 AWG22	HALL B
4	WHITE	UL1332 AWG22	HALL C
5	BLACK	UL1332 AWG22	GND HALL
			SENSOR GROUND
6	YELLOW	UL1332 AWG18	PHASE U
7	RED	UL1332 AWG18	PHASE V
8	BLACK	UL1332 AWG18	PHASE W



Brushless MOTOR

86BL

86BL

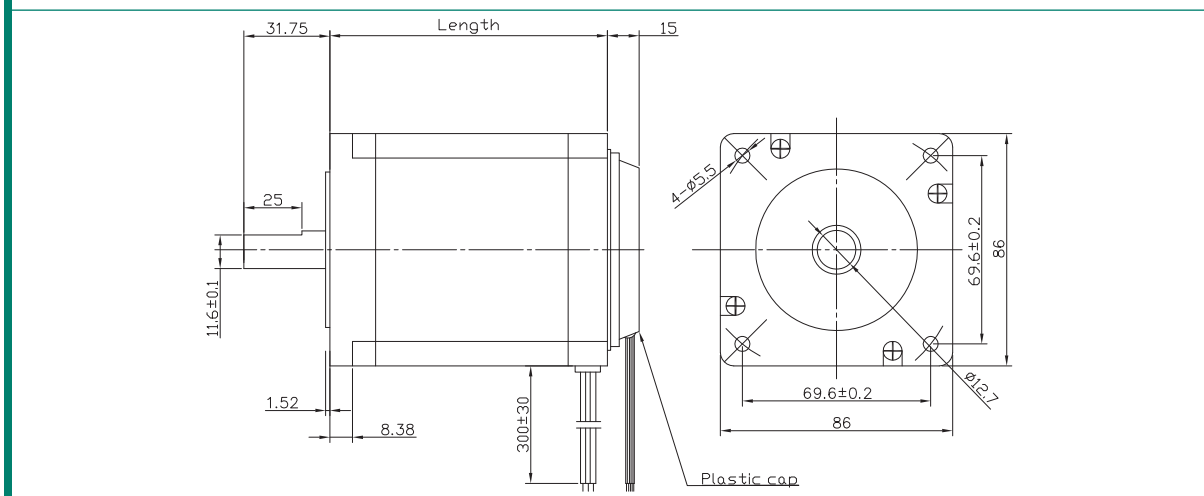

Specification

	86BL58		86BL71		86BL98		86BL125	
1 N° OF POLES	8		8		8		8	
2 N° OF PHASE	3		3		3		3	
3 RATED VOLTAGE	48		48		48		48	
4 TERMINAL RESISTANCE	01:05		00:36		00:02		00:16	
5 LINE TO LINE INDUCTANCE	02:02		01:05		00:48		00:03	
6 LENGTH	58		71		98		125	
7 ROTOR INERTIA G CM2	400		800		1600		2400	
8 CONNECTION	STAR	DELTA	STAR	DELTA	STAR	DELTA	STAR	DELTA
9 RATED SPEED	3000	6000	3000	6000	3000	6000	3000	6000
10 RATED TORQUE	0,35	0,175	0,7	0,35	1,4	0,7	2,1	1,05
11 MAX PEAK TORQUE	1,05	0,52	2,1	1,05	4,2	2,1	6,3	3,2
12 TORQUE CONSTANT	0,104	0,06	0,11	0,07	0,13	0,077	0,11	0,075
13 MAX PEAK CURRENT	10	8,6	19	15	33	27	57	42

Characteristics

HALL EFFECT ANGLE
120 ° ELECTRIC ANGLE

SHAFT RUN OUT
0,025 MM

INSULATION CLASS
B

RADIAL PLAY
0,02 MM (450 G LOAD)

AXIAL PLAY
0,08 MM (450 G LOAD)

MAX RADIAL FORCE
220 N (20 MM FROM FLANGE)

MAX AXIAL FORCE
60 N

DIELECTRIC STRENGTH
500 VDC FOR ONE MINUTE

INSULATION RESISTANCE
100 M OHM MIN. 500 VDC

Connection

LEAD N°	COLOR	GAUGE	FUNCTION
1	RED	UL1430 AWG22	VCC HALL SENSOR +5 TO +24 Vdc
2	BLUE	UL1430 AWG22	HALL A
3	GREEN	UL1430 AWG22	HALL B
4	WHITE	UL1430 AWG22	HALL C
5	BLACK	UL1430 AWG22	GND HALL SENSOR GROUND
6	YELLOW YELLOW/WHITE	UL1430 AWG16	PHASE U
7	RED RED/WHITE	UL1430 AWG16	PHASE V
8	BLACK BLACK/WHITE	UL1430 AWG16	PHASE W

Brushless MOTOR

28BL38-IE

28BL38-IE

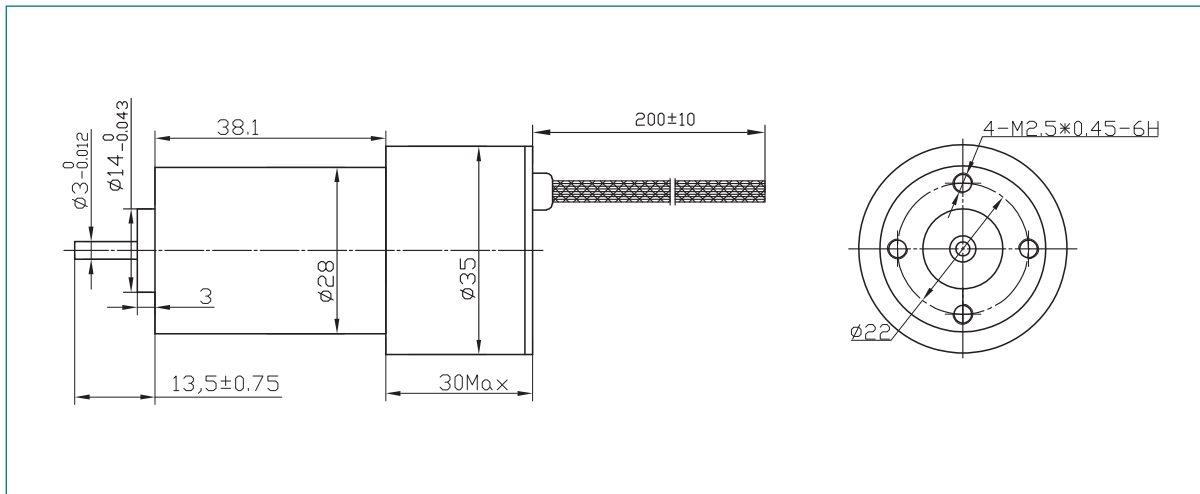

Characteristics

HALL EFFECT ANGLE
120 ° ELECTRIC ANGLE

SHAFT RUN OUT
0,025 MM

INSULATION CLASS
B

RADIAL PLAY
0,02 MM (450 G LOAD)

AXIAL PLAY
0,08 MM (450 G LOAD)

MAX RADIAL FORCE
15N 10MM FROM FLANGE

MAX AXIAL FORCE
10N

DIELECTRIC STRENGTH
500 VDC FOR ONE MINUTE

INSULATION RESISTANCE
100 M OHM MIN. 500 VDC

Specification

Model	28BL38-IE	
1 N° OF POLE		4
2 N° OF PHASE		3
3 RATED VOLTAGE	V	24
4 RATED SPEED	RPM	6000
5 RATED TORQUE	NM	0,016
6 MAX PEAK TORQUE	NM	0,039
7 TORQUE CONSTANT	NM/A	0,039
8 LINE TO LINE RESISTANCE	Ω	20,5
9 LINE TO LINE INDUCTANCE	MH	7,4
10 MAX PEAK CURRENT	A	1
11 LENGTH	MM	68
12 ROTOR INERTIA	G-CM ²	2,12
13 WEIGHT	Kg	0,15

Connection

LEAD N°	COLOR	GAUGE	FUNCTION
1	RED	UL1430 AWG26	VCC +
2	BLUE	UL1430 AWG26	GROUND
3	WHITE	UL1430 AWG26	ANALOG SPEED 1,2V - 3V
4	GREEN	UL1430 AWG26	DIRECTION

Brushless MOTOR

28BL38-IE2

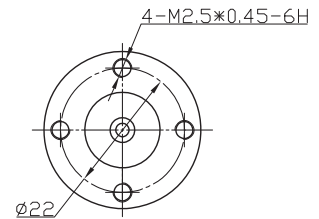
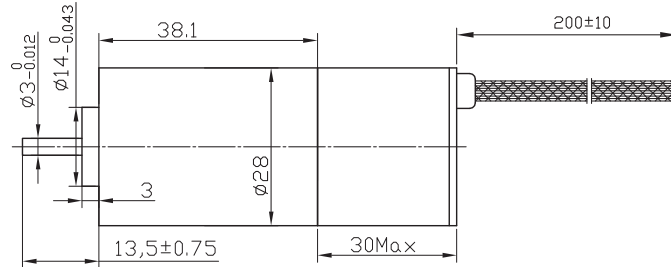

Specification

Model		28BL38-IE2	
1	N° OF POLE	4	
2	N° OF PHASE	3	
3	RATED VOLTAGE	V	24
4	RATED SPEED	RPM	6000
5	RATED TORQUE	NM	0,016
6	MAX PEAK TORQUE	NM	0,039
7	TORQUE CONSTANT	NM/A	0,039
8	LINE TO LINE RESISTANCE	Ω	20,5
9	LINE TO LINE INDUCTANCE	MH	7,4
10	MAX PEAK CURRENT	A	1
11	LENGTH	MM	68
12	ROTOR INERTIA	G-CM ²	2,12
13	WEIGHT	KG	0,15

Characteristics

HALL EFFECT ANGLE
120 ° ELECTRIC ANGLE

SHAFT RUN OUT
0,025 MM

INSULATION CLASS
B

RADIAL PLAY
0,02 MM (450 G LOAD)

AXIAL PLAY
0,08 MM (450 G LOAD)

MAX RADIAL FORCE
15N 10MM FROM FLANGE

MAX AXIAL FORCE
10N

DIELECTRIC STRENGTH
500 VDC FOR ONE MINUTE

INSULATION RESISTANCE
100 M OHM MIN. 500 VDC

Connection

LEAD N°	COLOR	GAUGE	FUNCTION
1	RED	UL1430 AWG26	Vcc +
2	BLUE	UL1430 AWG26	GROUND
3	GREEN	UL1007 AWG26	DIRECTION

Brushless MOTOR

33BL38-IE

33BL38-IE

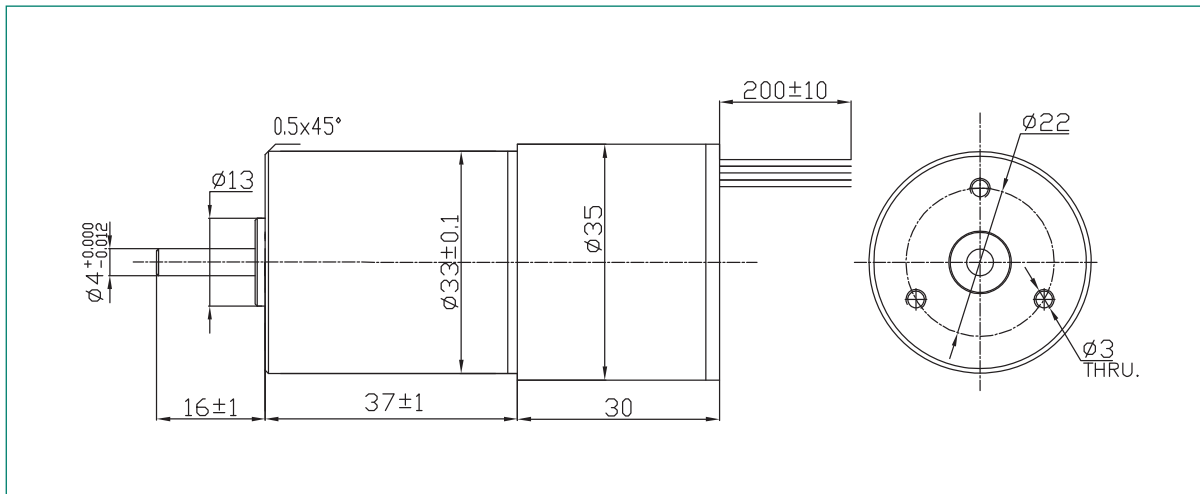

Characteristics

HALL EFFECT ANGLE
120 ° ELECTRIC ANGLE

SHAFT RUN OUT
0,025 MM

INSULATION CLASS
B

RADIAL PLAY
0,02 MM (450 G LOAD)

AXIAL PLAY
0,08 MM (450 G LOAD)

MAX RADIAL FORCE
15N 10MM FROM FLANGE

MAX AXIAL FORCE
10N

DIELECTRIC STRENGTH
500 VDC FOR ONE MINUTE

INSULATION RESISTANCE
100 M OHM MIN. 500 VDC

Specification

Model	33BL38-IE	
1 N° OF POLE		4
2 N° OF PHASE		3
3 RATED VOLTAGE	V	24
4 RATED SPEED	RPM	4500
5 RATED TORQUE	NM	0,022
6 MAX PEAK TORQUE	NM	0,066
7 TORQUE CONSTANT	NM/A	0,046
8 LINE TO LINE RESISTANCE	Ω	14,2
9 LINE TO LINE INDUCTANCE	MH	7
10 MAX PEAK CURRENT	A	1,45
11 LENGTH	MM	68
12 ROTOR INERTIA	G-CM ²	2,94
13 WEIGHT	Kg	0,2

Connection

LEAD N°	COLOR	GAUGE	FUNCTION
1	RED	UL1430 AWG26	VCC +
2	BLACK	UL1430 AWG26	GROUND
3	WHITE	UL1430 AWG26	ANALOG SPEED 1,2V - 3V
4	GREEN	UL1430 AWG26	DIRECTION

Brushless MOTOR

42BL-IE

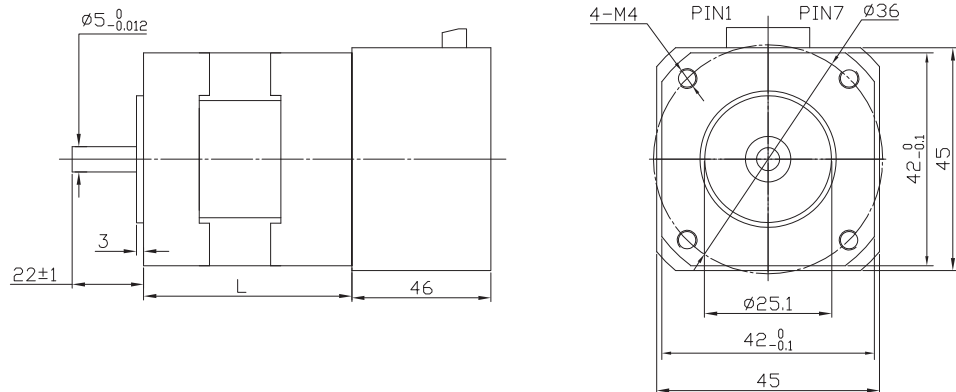

Specification

Model		42BL41-IE	42BL61-IE	42BL81-IE	42BL100-IE
1	N° OF POLE	8	8	8	8
2	N° OF PHASE	3	3	3	3
3	RATED VOLTAGE	V	24	24	24
4	RATED SPEED	RPM	4000	4000	4000
5	RATED TORQUE	NM	0,08	0,125	0,25
6	MAX PEAK TORQUE	NM	0,19	0,37	0,74
7	TORQUE CONSTANT	NM/A	0,038	0,035	0,038
8	LINE TO LINE RESISTANCE	Ω	1,6	0,8	0,3
9	LINE TO LINE INDUCTANCE	mH	1,94	1,2	0,5
10	MAX PEAK CURRENT	A	5	10,6	20
11	LENGTH	MM	92	107	146
12	ROTOR INERTIA	G-CM ²	48	48	96
13	WEIGHT	Kg	0,4	0,65	0,85

Characteristics

HALL EFFECT ANGLE
120° ELECTRIC ANGLE

SHAFT RUN OUT
0,025 MM

INSULATION CLASS
B

RADIAL PLAY
0,02 MM (450 G LOAD)

AXIAL PLAY
0,08 MM (450 G LOAD)

MAX RADIAL FORCE
28 N (10 MM FROM FLANGE)

MAX AXIAL FORCE
10 N

DIELECTRIC STRENGTH
500 VDC FOR ONE MINUTE

INSULATION RESISTANCE
100 M OHM MIN. 500 VDC

Connection

PIN N°	FUNCTION
1	+5V +5V VOLTAGE OUTPUT
2	F/R ROTATION DIRECTION
3	SV REFERENCE SPEED VOLTAGE 0/+5V
4	PG SPEED PULSE OUTPUT TTL.12 PULSE/REV.
5	GND COMMON GROUND SYSTEM
6	GND DC POWER INPUT GND
7	+VP DC POWER INPUT +24VDC

Brushless MOTOR

42RBL60-IE

42RBL60-IE

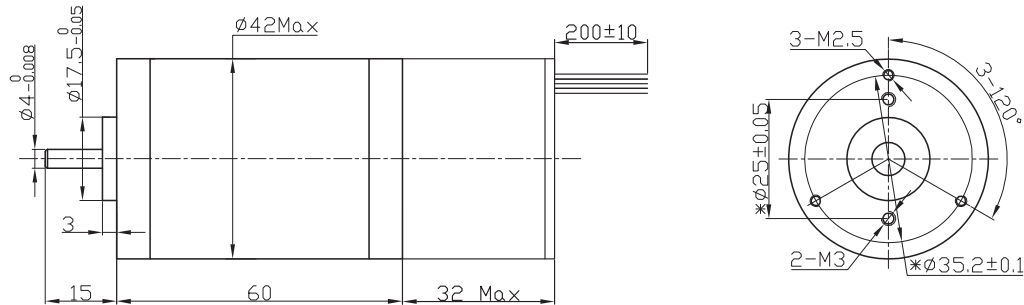

Characteristics

HALL EFFECT ANGLE
120° ELECTRIC ANGLE

SHAFT RUN OUT
0,025 MM

INSULATION CLASS
B

RADIAL PLAY
0,02 MM (450 G LOAD)

AXIAL PLAY
0,08 MM (450 G LOAD)

MAX RADIAL FORCE
28N 10MM FROM FLANGE

MAX AXIAL FORCE
10N

DIELECTRIC STRENGTH
500 VDC FOR ONE MINUTE

INSULATION RESISTANCE
100 M OHM MIN. 500 VDC

Specification

Model	42RBL60-IE	
1 N° OF POLE		8
2 N° OF PHASE		3
3 RATED VOLTAGE	V	24
4 RATED SPEED	RPM	4000
5 RATED TORQUE	NM	0,08
6 MAX PEAK TORQUE	NM	0,19
7 TORQUE CONSTANT	NM/A	0,038
8 LINE TO LINE RESISTANCE	Ω	1,6
9 LINE TO LINE INDUCTANCE	MH	1,94
10 MAX PEAK CURRENT	A	5
11 LENGTH	MM	92
12 ROTOR INERTIA	G-CM ²	48
13 WEIGHT	Kg	0,5

Connection

LEAD N°	COLOR	GAUGE	FUNCTION
1	RED	UL1430 AWG26	VCC +
2	BLACK	UL1430 AWG26	GROUND
3	WHITE	UL1430 AWG26	ANALOG SPEED 1,2V - 3V
4	GREEN	UL1430 AWG26	DIRECTION

Brushless MOTOR

57BL-IE

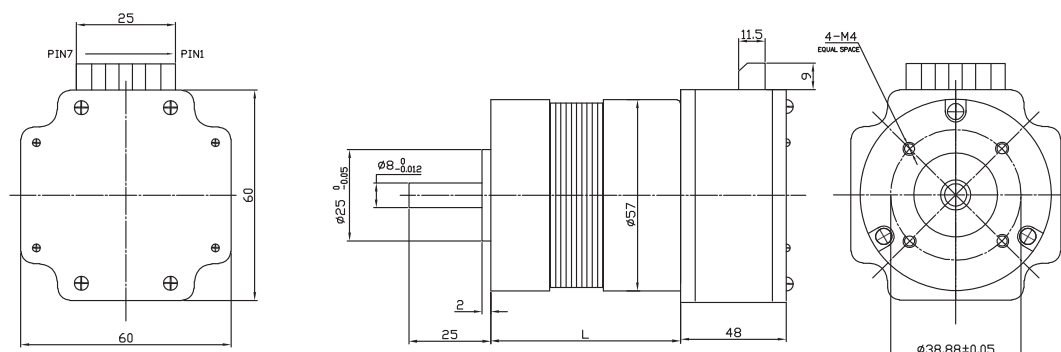

Specification

Model		57BL54-IE	57BL74-IE	57BL94-IE	57bl116-IE
1	N° OF POLE	4	4	4	4
2	N° OF PHASE	3	3	3	3
3	RATED VOLTAGE	V	36	36	36
4	RATED SPEED	RPM	4000	4000	4000
5	RATED TORQUE	NM	0,11	0,22	0,4
6	MAX PEAK TORQUE	NM	0,33	0,6	1
7	TORQUE CONSTANT	NM/A	0,063	0,063	0,063
8	LINE TO LINE RESISTANCE	Ω	1,5	0,6	0,38
9	LINE TO LINE INDUCTANCE	MH	4,5	2,1	1,65
10	MAX PEAK CURRENT	A	5	9,5	14
11	LENGTH	MM	102	122	142
12	ROTOR INERTIA	G-CM ²	75	119	230
13	WEIGHT	KG	00,7	0,95	1,2

Characteristics

HALL EFFECT ANGLE
120° ELECTRIC ANGLE

SHAFT RUN OUT
0,025 MM

INSULATION CLASS
B

RADIAL PLAY
0,02 MM (450 G LOAD)

AXIAL PLAY
0,08 MM (450 G LOAD)

MAX RADIAL FORCE
25N 10MM FROM FLANGE

MAX AXIAL FORCE
15N

DIELECTRIC STRENGTH
500 VDC FOR ONE MINUTE

INSULATION RESISTANCE
100 M OHM MIN. 500 VDC

Connection

PIN N°	FUNCTION
1	+5V +5V VOLTAGE OUTPUT
2	F/R ROTATION DIRECTION
3	SV REFERENCE SPEED VOLTAGE 0/+5V
4	PG SPEED PULSE OUTPUT TTL.12 PULSE/REV.
5	GND COMMON GROUND SYSTEM
6	GND DC POWER INPUT GND
7	+VP DC POWER INPUT +24VDC

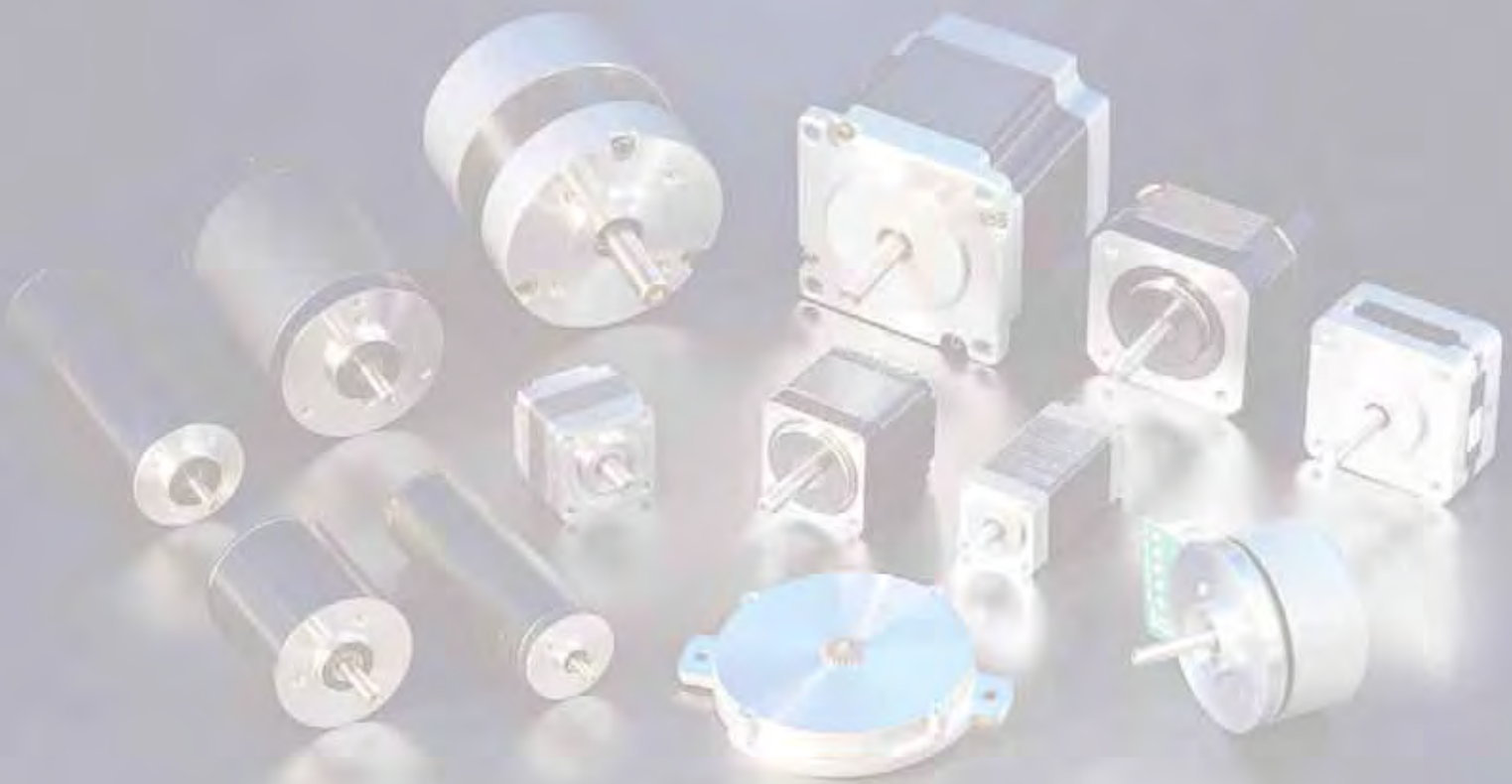

There are many different requirements for motor solutions, and rarely specific customer needs and wants can be achieved through the use of a standard motor.

This is the reason why **Fulling Motor** offers customized designs on all commercialized motors, even if small amounts of motors are requested.

The customization of **Fulling Motor** motors include simple modifications such as special shafts, wirings, connectors, pulleys, gears and encoders. In some specific situations, **Fulling Motor** is also available for the development of a totally new motor.

Fulling Motor means innovation, and that is why we are concentrated on research and development.

Being constantly up-to-date with new technologies, **Fulling Motor** offers the very best products at some of the most competitive prices in the market.

No matter how fast technology is moving, with **Fulling Motor** you will always find the perfect alloy for your business.

Fulling Motor gives a new idea of what is feasible, meaning that the customer is able to have totally personalized motors.

Fulling Motor's team is at the customer's service in order to find out the best technical and commercial solutions.



A



B



C



D



E



F



G



H



I



L



M



N



O

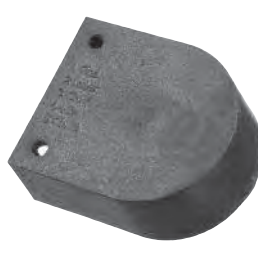

P

Special MOTOR

- A** SPECIAL COUPLING
- B** SPECIAL CHAMFER
- C** PRESS FIT PULLEY AND GEAR
- D** CONNECTORS
- E** HOLLOW SHAFT
- F** SPECIAL SHAFT LENGHT
- G** FLAT OR MULTI-FLATS SHAFTS
- H** SPECIAL CABLING
- I** CROSS DRILLED SHAFT
- L** CUSTOMIZED INTERFACE
- M** KNURLING
- N** INTERFERENCE SUPPRESSOR
- O** GEARBOX
- P** ENCODER

Stepper MOTOR basic

A stepper motor is an electromechanical device which converts electrical pulses into discrete mechanical movements. The shaft or spindle of a stepper motor rotates in discrete step increments when electrical command pulses are applied to it in the proper sequence. The motors rotation has several direct relationships to these applied input pulses. The sequence of the applied pulses is directly related to the direction of motor shafts rotation. The speed of the motor shafts rotation is directly related to the frequency of the input pulses and the length of rotation is directly related to the number of input pulses applied.

Stepper Motor Advantages and Disadvantages

ADVANTAGES

- 1 The rotation angle of the motor is proportional to the input pulse.
- 2 The motor has full torque at standstill (if the windings are energized)
- 3 Precise positioning and repeatability of movement since good stepper motors have an accuracy of 3 - 5% of a step and this error is non cumulative from one step to the next.
- 4 Excellent response to starting/stopping/reversing.
- 5 Very reliable since there are no contact brushes in the motor. Therefore the life of the motor is simply dependant on the life of the bearing.
- 6 The motors response to digital input pulses provides open-loop control, making the motor simpler and less costly to control.
- 7 It is possible to achieve very low speed synchronous rotation with a load that is directly coupled to the shaft.
- 8 A wide range of rotational speeds can be realized as the speed is proportional to the frequency of the input pulses.

DISADVANTAGES

- 1 Resonances can occur if not properly controlled.
- 2 Not easy to operate at extremely high speeds.

Open Loop Operation

One of the most significant advantages of a stepper motor is its ability to be accurately controlled in an open loop system. Open loop control means no feedback information about position is needed. This type of control eliminates the need for expensive sensing and feedback devices such as optical encoders. Your position is known simply by keeping track of the input step pulses.

Stepper motor type

There are three basic stepper motor types. They are:

- Variable - reluctance
- Permanent-magnet
- Hybrid

Variable-reluctance (vr)

This type of stepper motor has been around for a long time. It is probably the easiest to understand from a structural point of view.

Figure 1 shows a cross section of a typical V.R. stepper motor.

This type of motor consists of a soft iron multi-toothed rotor and a wound stator. When the stator windings are energized with DC current the poles become magnetized.

Rotation occurs when the rotor teeth are attracted to the energized stator poles.

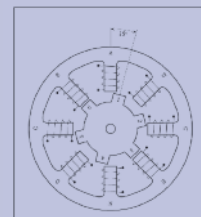

Fig. 1 - Cross-section of a variable-reluctance (VR) motor.

Permanent magnet (pm)

Often referred to as a "tin can" or "canstock" motor the permanent magnet step motor is a low cost and low resolution type motor with typical step angles of 7.5° to 15° .

(48 - 24 steps/revolution) PM motors as the name implies have permanent magnets added to the motor structure. The rotor no longer has teeth as with the VR motor. Instead the rotor is magnetized with alternating north and south poles situated in a straight line parallel to the rotor shaft. These magnetized rotor poles provide an increased magnetic flux intensity and because of this the PM motor exhibits improved torque characteristics when compared with the VR type.

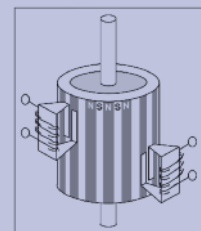

Fig. 2 - Principle of a PM or Tin-Can stepper motor.

Stepper MOTOR basic

Hybrid (hb)

The hybrid stepper motor is more expensive than the PM stepper motor but provides better performance with respect to step resolution, torque and speed.

Typical step angles for the HB stepper motor range from 3.6° to 0.9° (100 - 400 steps per revolution).

The hybrid stepper motor combines the best features of both the PM and VR type stepper motors. The rotor is multi-toothed like the VR motor and contains an axially magnetized concentric magnet around its shaft.

The teeth on the rotor provide an even better path which helps guide the magnetic flux to preferred locations in the airgap. This further increases the detent, holding and dynamic torque characteristics of the motor when compared with both the VR and PM types.

The two most commonly used types of stepper motors are the permanent magnet and the hybrid types. If a designer is not sure which type will best fit his applications requirements he should first evaluate the PM type as it is normally several times less expensive. If not then the hybrid motor may be the right choice.

There also exist some special stepper motor designs. One is the disc magnet motor. Here the rotor is designed as a disc with rare earth magnets, See fig. 4.

This motor type has some advantages such as very low inertia and a optimized magnetic flow path with no coupling between the two stator windings. These qualities are essential in some applications.

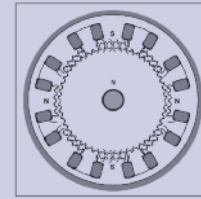

Fig. 3 - Cross-section of a hybrid stepper motor.

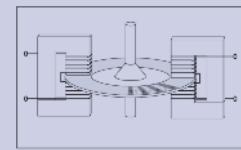

Fig. 4 - Principle of a Disc Magnet motor developed by Portescap

Size and power

In addition to being classified by their step angle stepper motors are also classified according to frame sizes which correspond to the diameter

of the body of the motor. For instance a size 11 stepper motor has a body diameter of approximately 1.1 inches.

Likewise a size 23 stepper motor has a body diameter of 2.3 inches (58 mm), etc. The body length may however, vary from motor to motor within the same frame size classification. As a general rule the available torque output from a motor of a particular frame size will increase with increased body length. Power levels for IC-driven stepper motors typically range from below a watt for very small motors up to 10 - 20 watts for larger motors. The maximum power dissipation level or thermal limits of the motor are seldom clearly stated in the motor manufacturers data. To determine this we must apply the relationship $P = V \cdot I$. For example, a size 23 step motor may be rated at 6V and 1A per phase. Therefore, with two phases energized the motor has a rated power dissipation of 12 watts. It is normal practice to rate a stepper motor at the power dissipation level where the motor case rises 65°C above the ambient in still air. Therefore, if the motor can be mounted to a heat-sink it is often possible to increase the allowable power dissipation level. This is important as the motor is designed to be and should be used at its maximum power dissipation, to be efficient from a size/output power/cost point of view.

When to Use a Stepper Motor

A stepper motor can be a good choice whenever controlled movement is required. They can be used to advantage in applications where you need to control rotation angle, speed, position and synchronism. Because of the inherent advantages listed previously, stepper motors have found their place in many different applications. Some of these include printers, plotters, scanners, high-end office equipment, hard disk drives, fax machines and many more.

The Rotating Magnetic Field

When a phase winding of a stepper motor is energized with current a magnetic flux is developed in the stator. The direction of this flux is determined by the "Right Hand Rule" which states: "If the coil is grasped in the right hand with the fingers pointing in the direction of the current in the winding (the thumb is extended at a 90° angle to the fingers), then the thumb will point in the direction of the magnetic field." Figure 5 shows the magnetic flux path developed when phase B is energized with winding current in the direction shown. The rotor then aligns itself so that the flux opposition is minimized. In this case the motor would rotate clockwise so that its south pole aligns with the north pole of the stator B at position 2 and its north pole aligns with the south pole of stator B at position 6. To get the motor to rotate we can now see that we must provide a sequence of energizing the stator windings in such a fashion that provides a rotating magnetic flux field which the rotor follows due to magnetic attraction.

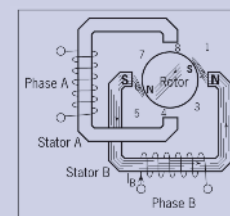

Fig. 5 - Magnetic flux path through a two-pole stepper motor with a lag between the rotor and stator.

Stepper MOTOR basic

Torque Generation

The torque produced by a stepper motor depends on several factors.

- The step rate
- The drive current in the windings
- The drive design or type

In a stepper motor a torque is developed when the magnetic fluxes of the rotor and stator are displaced from each other. The stator is made up of a high permeability magnetic material.

The presence of this high permeability material causes the magnetic flux to be confined for the most part to the paths defined by the stator structure in the same fashion that currents are confined to the conductors of an electronic circuit.

This serves to concentrate the flux at the stator poles.

The torque output produced by the motor is proportional to the intensity of the magnetic flux generated when the winding is energized.

The basic relationship which defines the intensity of the magnetic flux is defined by:

$H = (N \cdot i) / l$ where:

H = Magnetic field intensity

N = The number of winding turns

i = current

l = Magnetic flux path length

This relationship shows that the magnetic flux intensity and consequently the torque is proportional to the number of winding turns and the current and inversely proportional to the length of the magnetic flux path.

From this basic relationship one can see that the same frame size stepper motor could have very different torque output capabilities simply by changing the winding parameters.

Phases, Poles and Stepping Angles

Usually stepper motors have two phases, but three- and five-phase motors also exist. A bipolar motor with two phases has one winding/phase and a unipolar motor has one winding, with a center tap per phase. Sometimes the unipolar stepper motor is referred to as a “four-phase motor”, even though it only has two phases. Motors that have two separate windings per phase also exist, these can be driven in either bipolar or unipolar mode.

A pole can be defined as one of the regions in a magnetized body where the magnetic flux density is concentrated. Both the rotor and the stator of a step motor have poles.

Figure 5 contains a simplified picture of a two-phase stepper motor having 2 poles (or 1 pole pairs) for each phase on the stator, and 2 poles (one pole pair) on the rotor. In reality several more poles are added to both the rotor and stator structure in order to increase the number of steps per revolution of the motor, or in other words to provide a smaller basic (full step) stepping angle. The permanent magnet stepper motor contains an equal number of rotor and stator pole pairs.

Typically the PM motor has 12 pole pairs. The stator has 12 pole pairs per phase. The hybrid type stepper motor has a rotor with teeth.

The rotor is split into two parts, separated by a permanent magnet, making half of the teeth south poles and half north poles.

The number of pole pairs is equal to the number of teeth on one of the rotor halves.

The stator of a hybrid motor also has teeth to build up a higher number of equivalent poles (smaller pole pitch, number of equivalent poles = $360/\text{teeth pitch}$) compared to the main poles, on which the winding coils are wound.

Usually 4 main poles are used for 3.6 hybrids and 8 for 1.8- and 0.9-degree types. It is the relationship between the number of rotor poles and the equivalent stator poles, and the number the number of phases that determines the full-step angle of a stepper motor.

$$\text{step angle} = 360 / (NPh \cdot Ph) = 360/N$$

NPh= Number of equivalent poles per phase = number of rotor poles

Ph = Number of phases

N = Total number of poles for all phases together

If the rotor and stator tooth pitch is unequal, a more-complicated relationship exists.

Stepper MOTOR basic

Stepping Modes

The following are the most common drive modes.

- Wave Drive (1 phase on)
- Full Step Drive (2 phases on)
- Half Step Drive (1 & 2 phases on)
- Microstepping (Continuously varying motor currents)

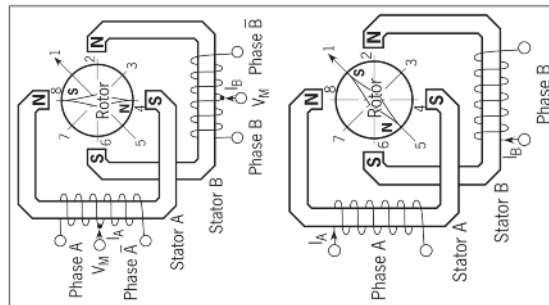

Fig. 6 - Unipolar and bipolar wound stepper motors

For the following discussions please refer to the figure 6.

In Wave Drive only one winding is energized at any given time. The stator is energized according to the sequence **A - B - A - B** and the rotor steps from position **8 - 2 - 4 - 6**.

For unipolar and bipolar wound motors with the same winding parameters this excitation mode would result in the same mechanical position. The disadvantage of this drive mode is that in the unipolar wound motor you are only using 25% and in the bipolar motor only 50% of the total motor winding at any given time. This means that you are not getting the maximum torque output from the motor. In Full Step Drive you are energizing two phases at any given time.

The stator is energized according to the sequence **AB - AB - AB** and the rotor steps from position **1 - 3 - 5 - 7**.

Full step mode results in the same angular movement as 1 phase on drive but the mechanical position is offset by one half of a full step. The torque output of the unipolar wound motor is lower than the bipolar motor (for motors with the same winding parameters) since the unipolar motor uses only 50% of the available winding while the bipolar motor uses the entire winding. Half Step Drive combines both wave and full step (1&2 phases on) drive modes.

Every second step only one phase is energized and during the other steps one phase on each stator. The stator is energized according to the sequence **AB - B - AB - A - AB - B - AB - A** and the rotor steps from position **1 - 2 - 3 - 4 - 5 - 6 - 7 - 8**.

This results in angular movements that are half of those in 1 or 2 -phases- on drive modes. Half stepping can reduce a phenomena referred to as resonance which can be experienced in 1 or 2 -phases- on drive modes.

The excitation sequences for the above drive modes are summarized in Table 1.

In Microstepping Drive the currents in the windings are continuously varying to be able to break up one full step into many smaller discrete steps.

Phase	Wave Drive	Normal full step	Half-step drive
	1 2 3 4	1 2 3 4	1 2 3 4 5 6 7 8
A	•	•	•
B		•	•
A		•	•
B		•	•

Table. 1 - Excitation sequences for different drives modes

Stepper MOTOR basic

Torque vs, Angle Characteristics (hb)

The torque vs angle characteristics of a stepper motor are the relationship between the displacement of the rotor and the torque which applied to the rotor shaft when the stepper motor is energized at its rated voltage. An ideal stepper motor has a sinusoidal torque vs displacement characteristic as shown in figure 7. Positions A and C represent stable equilibrium points when no external force or load is applied to the rotor shaft. When you apply an external force T_a to the motor shaft you in essence create an angular displacement, Q_a .

This angular displacement, Q_a , is referred to as a lead or lag angle depending on whether the motor is actively accelerating or decelerating. When the rotor stops with an applied load it will come to rest at the position defined by this displacement angle. The motor develops a torque, T_a , in opposition to the applied external force in order to balance the load. As the load is increased the displacement angle also increases until it reaches the maximum holding torque, T_h , of the motor. Once T_h is exceeded the motor enters an unstable region. In this region a torque in the opposite direction is created and the rotor jumps over the unstable point to the next stable point. The displacement angle is determined by the following relationship:

$$X = (Z / 2p) \cdot \sin(T_a / T_h) \text{ where:}$$

Z = Rotor tooth pitch
 T_a = Load torque
 T_h = Motors rated holding torque
 X = Displacement angle.

Therefore if you have a problem with the step angle error of the loaded motor at rest you can improve this by changing the "stiffness" of the motor. This is done by increasing the holding torque of the motor. We can see this effect shown in the figure 8. Increasing the holding torque for a constant load causes a shift in the lag angle from Q_2 to Q_1 .

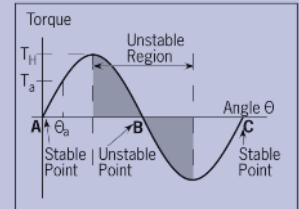

Fig. 7 - Torque vs. rotor angular position.

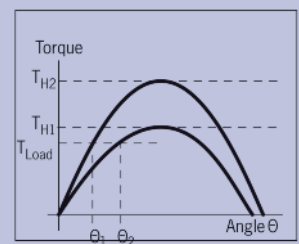

Fig. 8 - Torque vs. rotor angle position at different holding torque.

Torque vs, Angle Characteristics (hb)

One reason why the stepper motor has achieved such popularity as a positioning device is its accuracy and repeatability.

Typically stepper motors will have a step angle accuracy of 3-5% of one step. This error is also noncumulative from step to step.

The accuracy of the stepper motor is mainly a function of the mechanical precision of its parts and assembly. Figure 9 shows a typical plot of the positional accuracy of a stepper motor.

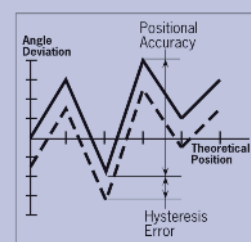

Fig. 9 - Positional accuracy of a stepper motor.

Step Position Error

The maximum positive or negative position error caused when the motor has rotated one step from the previous holding position. Step position error = measured step angle - theoretical angle

Position Error

The motor is stepped N times from an initial position ($N = 360^\circ / \text{step angle}$) and the angle from the initial position is measured at each step position. If the angle from the initial position to the N -step position is Q_N and the error is DQN where: $DQN = Q_N - (\text{step angle}) \cdot N$.

The positional error is the difference of the maximum and minimum but is usually expressed with a \pm sign. That is: positional error = $\pm 1.2 (DQ_{Max} - DQ_{Min})$

Hysteresis Position Error

The values obtained from the measurement of positional errors in both directions.

Stepper MOTOR basic

Meccanical Parameters, Load, Friction, Inertia

The performance of a stepper motor system (driver and motor) is also highly dependent on the mechanical parameters of the load. The load is defined as what the motor drives. It is typically frictional, inertial or a combination of the two.

Friction is the resistance to motion due to the unevenness of surfaces which rub together. Friction is constant with velocity. A minimum torque level is required throughout the step in order to overcome this friction (at least equal to the friction). Increasing a frictional load lowers the top speed, lowers the acceleration and increases the positional error. The converse is true if the frictional load is lowered. Inertia is the resistance to changes in speed. A high inertial load requires a high inertial starting torque and the same would apply for braking. Increasing an inertial load will increase speed stability, increase the amount of time it takes to reach a desired speed and decrease the maximum self start pulse rate.

The converse is again true if the inertia is decreased. The rotor oscillations of a stepper motor will vary with the amount of friction and inertia load. Because of this relationship unwanted rotor oscillations can be reduced by mechanical damping means however it is more often simpler to reduce these unwanted oscillations by electrical damping methods such as switch from full step drive to half step drive.

Torque vs, Speed Characteristics

The torque vs speed characteristics are the key to selecting the right motor and drive method for a specific application. These characteristics are dependent upon (change with) the motor, excitation mode and type of driver or drive method. A typical “speed – torque curve” is shown in figure 10.

To get a better understanding of this curve it is useful to define the different aspect of this curve.

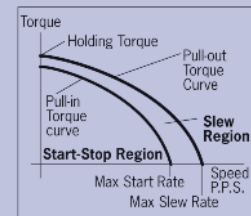

Fig. 10 - Torque vs. speed characteristics of a stepper motor.

Holding Torque

The maximum torque produced by the motor at standstill.

Pull-In Curve

The pull-in curve defines a area refered to as the start stop region.

This is the maximum frequency at which the motor can start/stop instantaneously, with a load applied, without loss of synchronism.

Maximum Start Rate

The maximum starting step frequency with no load applied.

Pull-In Curve

The pull-out curve defines an area refered to as the slew region. It defines the maximum frequency at which the motor can operate without losing synchronism.

Since this region is outside the pull-in area the motor must ramped (accelerated or decelerated) into this region.

Maximum Slew Rate

The maximum operating frequency of the motor with no load applied.

The pull-in characteristics vary also depending on the load. The larger the load inertia the smaller the pull-in area. We can see from the shape of the curve that the step rate affects the torque output capability of stepper motor.

The decreasing torque output as the speed increases is caused by the fact that at high speeds the inductance of the motor is the dominant circuit element. The shape of the speed - torque curve can change quite dramatically depending on the type of driver used.

The bipolar chopper type drivers which New JRC produces will maximum the speed - torque performance from a given motor. Most motor manufacturers provide these speed - torque curves for their motors.

It is important to understand what driver type or drive method the motor manufacturer used in developing their curves as the torque vs. speed characteristics of an given motor can vary significantly depending on the drive method used.

Stepper MOTOR basic

Single Step Response and Resonances

The single-step response characteristics of a stepper motor is shown in figure 11.

When one step pulse is applied to a stepper motor the rotor behaves in a manner as defined by the above curve. The step time t is the time it takes the motor shaft to rotate one step angle once the first step pulse is applied. This step time is highly dependent on the ratio of torque to inertia (load) as well as the type of driver used.

Since the torque is a function of the displacement it follows that the acceleration will also be. Therefore, when moving in large step increments a high torque is developed and consequently a high acceleration. This can cause overshoots and ringing as shown. The settling time T is the time it takes these oscillations or ringing to cease. In certain applications this phenomena can be undesirable. It is possible to reduce or eliminate this behaviour by microstepping the stepper motor.

Stepper motors can often exhibit a phenomena referred to as resonance at certain step rates. This can be seen as a sudden loss or drop in torque at certain speeds which can result in missed steps or loss of synchronism. It occurs when the input step pulse rate coincides with the natural oscillation frequency of the rotor. Often there is a resonance area around the 100 – 200 pps region and also one in the high step pulse rate region. The resonance phenomena of a stepper motor comes from its basic construction and therefore it is not possible to eliminate it completely. It is also dependent upon the load conditions. It can be reduced by driving the motor in half or microstepping modes.

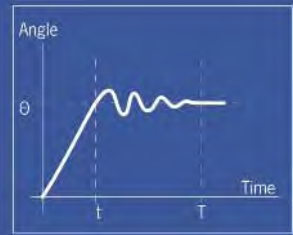

Fig. 7 - Torque vs. rotor angular position.

Brushless Dc MOTOR basic

Magnetics 1

If current is caused to flow in the armature conductors, torque is produced.

There is an application of a law of physics which is expressed as: $F = KBIi$

Where:

F = force - K = a constant - B = air gap flux density - l = length of the conductor - i = current in a conductor

If more than one conductor is carrying the same current (multiple turns per coil), then $F = KBZi$

Where Z = number of conductors in series. In a motor the conductors rotate about a central shaft (see figure 1). Then torque, $T = FR$, where R = radius at the air gap. So, $T = KRBIzi$

Figure 1 shows the coil in the zero torque position. The maximum torque position is 90 electrical degrees from the position shown. As the conductors rotate from the maximum torque position, torque drops off in a sinusoidal fashion and becomes zero when the coil has moved 90 degrees.

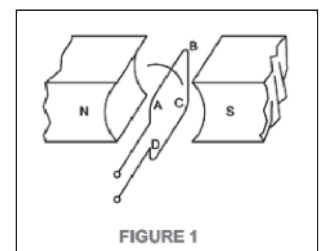

Fig. 1 - Simplified illustration of how torque is generated in a permanent magnet DC motor

Magnetics 2

A brush type motor has more than one coil. Each coil is angularly displaced from one another

so that when the torque from one coil has dropped off, current is automatically switched to another coil which is properly located to produce maximum torque. The switching is accomplished mechanically with brushes and a commutator as shown in Figure 2

In a brushless motor, the position of the coils (phases), with respect to the permanent magnet field, is sensed electronically and the current is switched, or commutated, to the appropriate phases. The commutation is effected by means of transistor switches.

A brush type motor may be converted into a brushless motor by bringing out all the leads that are attached to the mechanical commutator and providing switches for each lead; however, this approach would involve a large number of switches.

Instead, a polyphase winding similar to that used in AC motors is utilized. In this design, the phases are commutated as a function of shaft position.

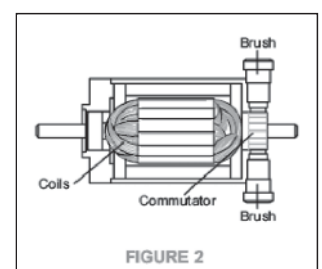

Fig. 2 - Brush DC MOTOR

Brushless Dc MOTOR basic

3-Phase Connections

Two, three and four phase motor design are common. DPM provide three phase design.

This configuration optimizes performance even though it requires more electronic components. Three types of three phase windings are available: Delta bipolar, wye unipolar and wye bipolar. These three winding configurations and their transistor orientation are shown in Figure 3

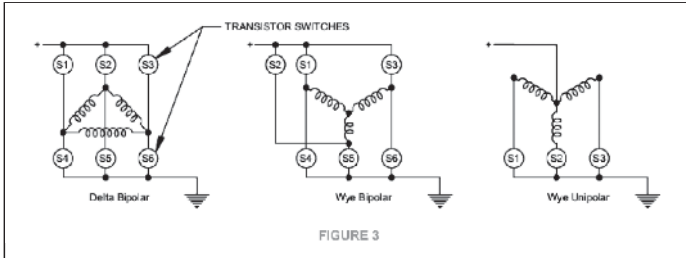

Fig. 3 - Bipolar and unipolar configuration

Torque vs, Speed Characteristics

Figure 4 illustrates the sequential steps in the commutation of a three phase ,bi-polar system. Closing the transistors 1 and 4 will enable current to flow through phase A and B. The permanent magnet rotor will then align itself in a zero torque,preferred position. If 1 is opened and 5 closed, current will flow through phases B and C, the rotor will move 120 electrical degrees. (Note that the current through phase A is now flowing in the direction opposite the one at the start of this exercise.) Obviously, there must be some logic in the order and rate the transistor are switched. Hall Effect sensors are typically used in the logic scheme. Graph 1 may help illustrate how this works.

For instance, if one were to energize individual phases of a three phase brushless motor one would generate, as a function of electrical degrees of rotation, a torque curve as shown in Graph 1. Each phase would be 120 electrical degrees apart. (It should be noted that electrical degrees is simply mechanical degrees multiplied by the number of pole pairs of the motor). Now, imagine the rotor in Figure 4 resting in its zero torque position (i.e. the 180 electrical degree point of the Graph 1), with current flowing trough winding A. If the rotor is physically moved back from its rest position, torque will build up roughly sinusoidally and become peak at 90 electrical degrees. Since the objective is to have the motor run at its peak operating point, the position still another 30 degrees back from the peak torque point, or 60 degrees, is the point at which the winding must be switched on.

A sensor is located to trigger from a rotor magnet at this specific event. If the roor is allowed to turn back towards its original rest, or zero torque point, but the current is switched from winding A to winding B at 180 electrical degrees, the motor will operate on a new sine wave, or torque vs. angle, resulting in another point of peak performance. Again, a sensor is located in such a manner to mark this event. Similarly, the third sensor is set to trigger at 300 electrical degrees. These Hall Effect sensor setting, 120 electrical degrees apart from sensor to sensor, automatically sequence the switching of currents from one phase to another, at the appropriate time. Another important point to note from Graph 1 is the sign of the torque generated as a function of rotor position. If the currents in individual phases were switched at the proper electrical position, positive torque could always be generated, as illustrated in Graph 2. With the proper selection of phase energization (i.e. the proper commutation scheme) the resultant torque output of the motor is as illustrated in Graph 3. The successful commutation of the brushless motor is knowing the rotor position in electrical degrees and having the proper commutation scheme.

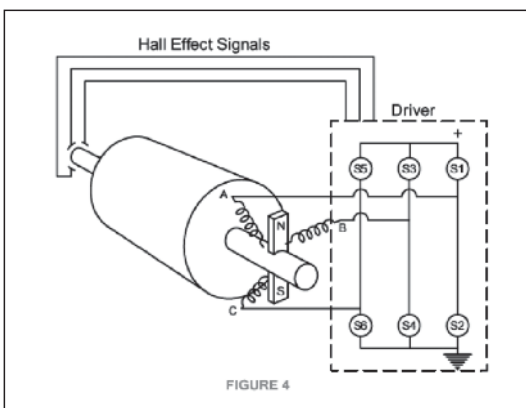
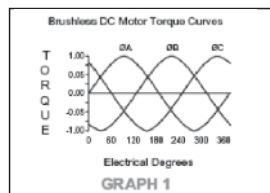
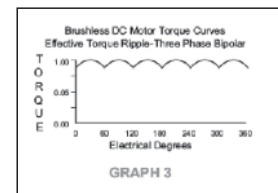

Figure. 4 - Rotor position



Graph 1



Graph 3

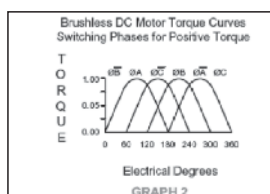

Graph 2

Brushless Dc MOTOR basic

Brushless Motor Sizing

The nature of the application under consideration dictates what information is required to properly select a motor candidate.

For example, operating at a fixed speed will have a different demand than operation under servo conditions. In general, three parameters will determine motor selection: 1 Peak torque requirement - 2 RMS torque requirement - 3 Speed of operation

PEAK TORQUE REQUIREMENT

Peak torque T_p is the sum of the torque due to acceleration of inertia, T_j , load, T_l , and friction T_f : $T_p = T_j + T_l + T_f$
 Looking at the separate components, the torque due to inertia is the product of the load (including motor rotor) inertia and the load acceleration: $T_j = J * a$ (a = acceleration) The torque due to the load is defined by the configuration of the mechanical system coupled to the motor. The system also determines the amount of torque required to overcome the friction.

RMS TORQUE REQUIREMENT

Root-Mean-Square or RMS torque is a value used to approximate the average continuous torque requirement. It is a statistical approximation described by the following equation Where t_1 is the acceleration time, t_2 is the run time, t_3 is the deceleration time, and t_4 is the time in a move

$$T_{RMS} = \sqrt{\frac{T_p^2 t_1 + (T_l + T_f)^2 t_2 + (T_j - T_l - T_f)^2 t_3}{t_1 + t_2 + t_3 + t_4}}$$

FIG. 5 - RMS TORQUE FORMULA

SPEED OF OPERATION

Speed of operation is also dictated by the configuration of the mechanical system that is coupled to the motor shaft, and by the type of move that is to be effected. For example, a single speed application would require a motor with rated speed equal to the average move speed. A point to point positioning application would require a motor with a rated speed higher than the average move speed.

(The higher speed would account for acceleration, deceleration and run times of the motion profile).

Figure 8A and 8B relate rated operating speed to average move speed for point to point positioning move profiles.

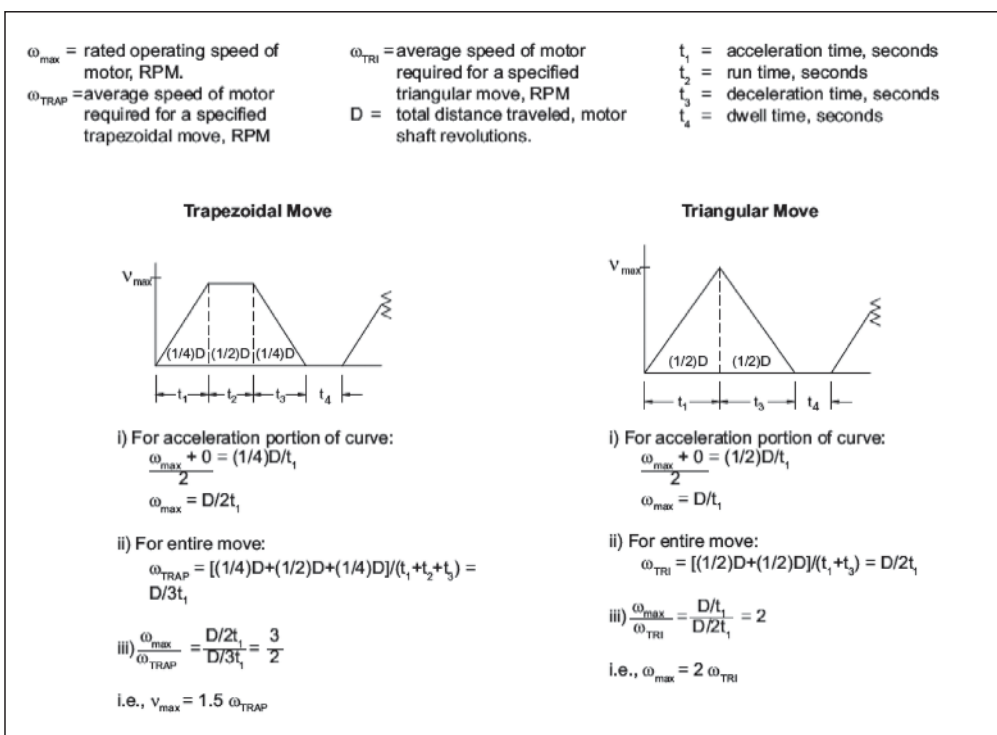

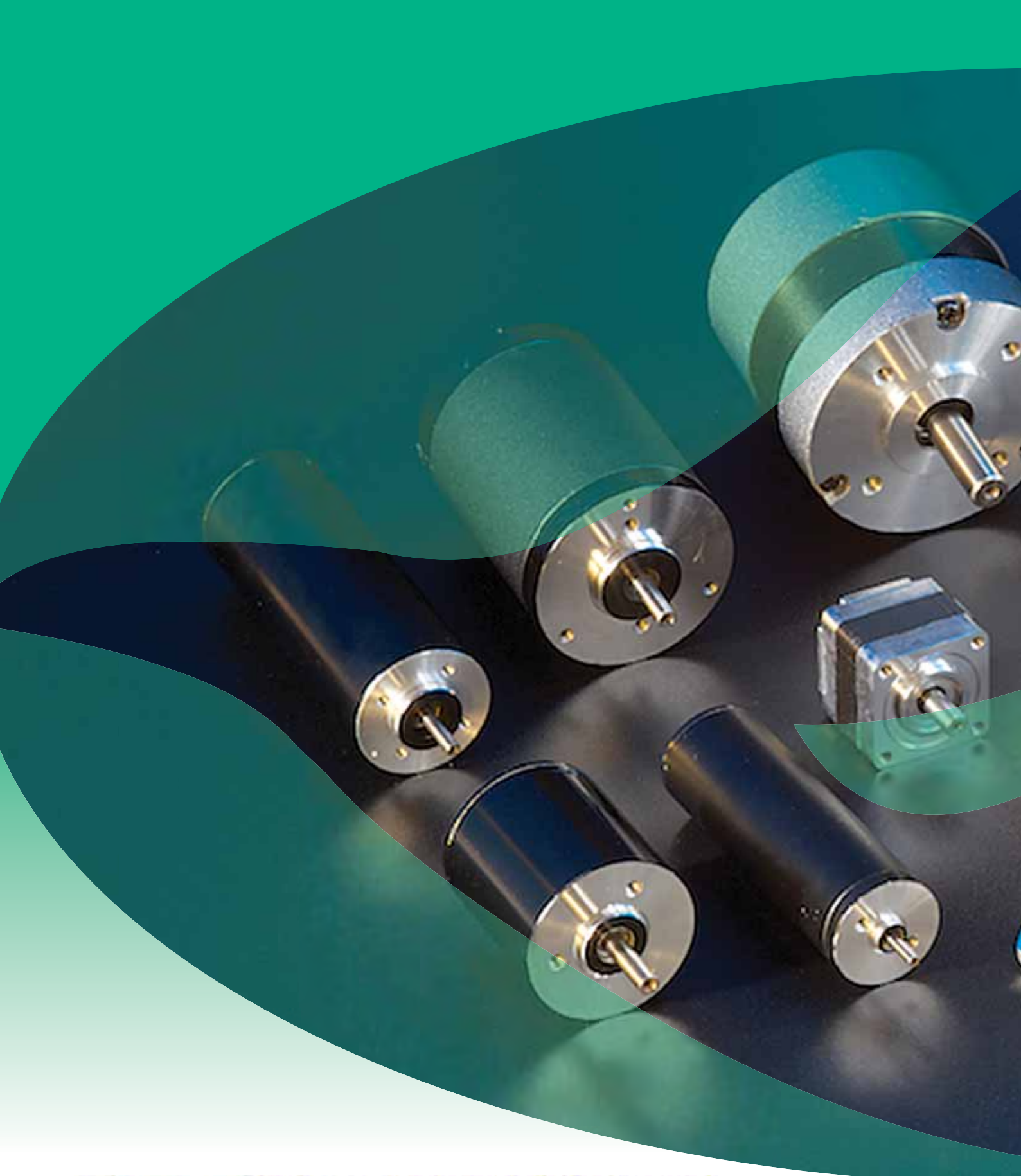

Distributors for Australia & New Zealand

MOTION TECHNOLOGIES PTY LTD

24/22-30 Northumberland Road
Caringbah NSW 2229 Australia
Phone: (02) 9524 4782
Fax: (02) 9525 3878

sales@motiontech.com.au
www.motiontech.com.au

© 20/03/19