

LIFT SYSTEMS

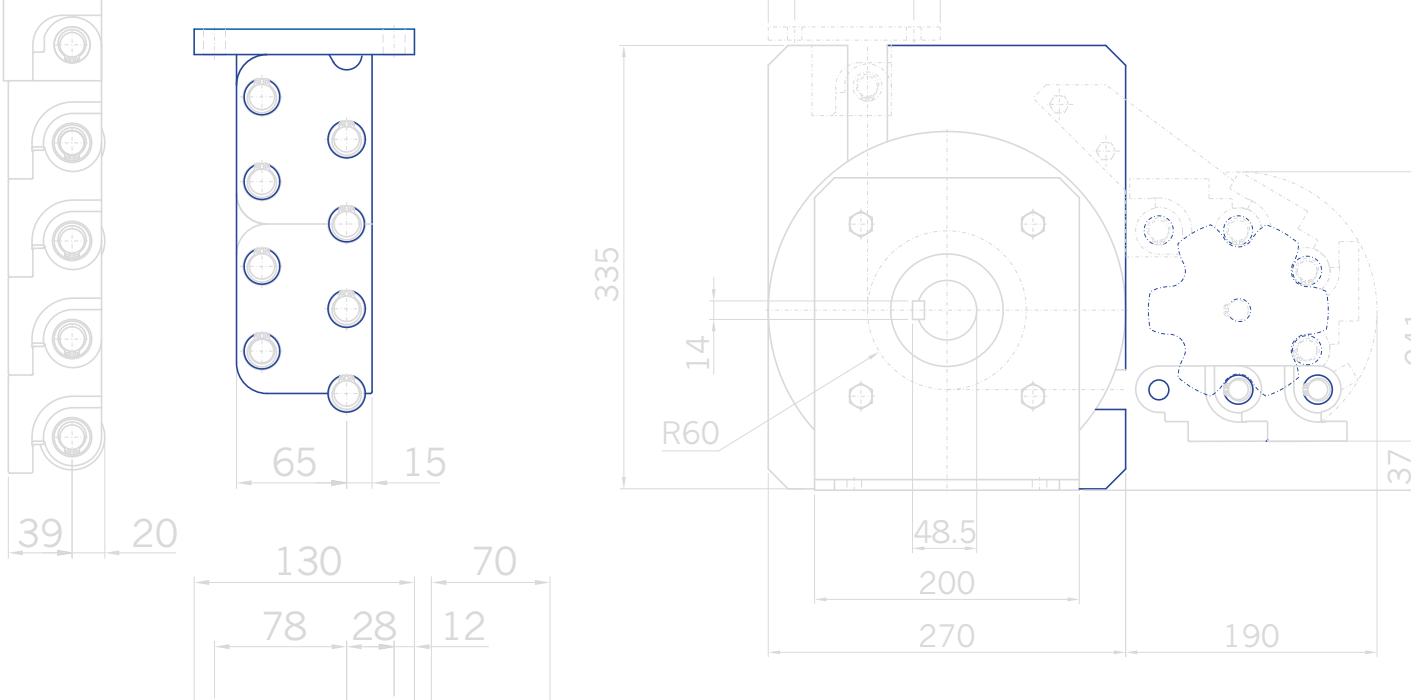

SERAPID

rigid-chain technology
for vertical movement

operating principles

system design

lift systems for standard and heavy-duty applications



SERAPID lifting systems are designed to elevate heavy loads using a purely mechanical principle. As with our horizontal motion systems, this principle is about the locking and unlocking of flexibly connected, chained elements. When locked, these elements will work like a bar or column; when unlocked they will bend and even coil into a space-saving package. This mechanism is at work in any SERAPID motion system. And there are many other

benefits, besides saving space, such as positioning accuracy and range, or operating reliability.

This brochure is intended to give you first-hand information about **rigid-chain technology for vertical movements**. Moreover, we want to show you the practical solutions that we, the original supplier of that technology, have to offer. This information is provided both for beginners, installing their first

SERAPID system ever, as well as for experienced engineers who have dealt successfully with a variety of linear motion tasks.

Whether you want an easy introduction to the technology or are more interested in a solution for your actual application, you should find here most of the answers you need. But for the rest, SERAPID Application Engineering is ready to take your call.

configure your SERAPID lift system step by step

To select your SERAPID lift system, just follow the steps outlined below. For details consult the pages indicated for each of the steps. For comprehensive information about the technology, we recommend that you read this brochure from cover to cover.

- **Determine the total load.** In addition to the weight of the items moved, friction, acceleration and deceleration forces have to be considered. Also, the height of the stroke plays a decisive role. **See page 10.**

- **Heavy- or Standard-Duty?** For especially high cycling rates, SERAPID provides one line of products designed specially for **heavy-duty operation, with a guaranteed minimum lifetime of one million cycles**. Application domains for this product line are chiefly found in industry, for example, in automotive manufacturing. If you do not require this degree of ruggedness and resistance to wear, the SERAPID line of **standard-duty** lift systems will certainly meet your needs. For the difference between standard and heavy-duty products, see **page 11.**

- **How can the lift be stored?** SERAPID lift systems allow storage of the inactive lift strand in horizontal orientation on one of two sides of the lifting column. It is possible to store the lift strand in a loop so it takes less space. **See page 9.**



4 System design: Depending on the size of the load or the lifting platform, a standard system may comprise several lift columns driven synchronously by one gear motor. Two and even more such systems can be combined for platforms of virtually any size. The total system load is distributed on the individual lift columns. **See page 8** for details.

5 Which type of lift? SERAPID lift systems are available in a variety of designs to satisfy various application needs. If your application involves only standard cycling rates, see **pages 12 – 13** for an overview of types. If you require a heavy-duty system, see **pages 18 – 19**. When consulting the capacity charts provided for each of the prod-

uct lines, keep in mind that the values specified are subject to certain standard conditions. – Consult SERAPID for special cases.

6 Consult the technical drawing. Once you have found your appropriate lift type, consult the corresponding technical drawing. The drawings provide detailed information on the dimensions of the equipment. The standard-duty products are found on **pages 14 – 17**, the heavy-duty products on **pages 20 – 23**.

The drawings can also be downloaded from our website at **www.serapid.com**, or obtained on CD ROM by calling or e-mailing any SERAPID office worldwide.

7 Calculate the length of the lift strand. See **page 11** for instructions.

8 Calculate the drive power. See **page 10** for the formulas to use. If you wish, we can supply the motor together with your system.

9 Fill out the SERAPID Application Questionnaire. Describe your application and desired solution in as much detail as necessary, then send the questionnaire back to us. You will promptly receive your quotation. If you still have any questions or require special equipment, call us.

SERAPID



| contents | |
|--|------|
| | page |
| the SERAPID chain | 4 |
| how the chain lifts a load | 6 |
| system configuration | 8 |
| possibilities of storage | 9 |
| calculating thrust force and drive power | 10 |
| calculating the length of the lift strands | 11 |
| standard-duty and heavy-duty lift systems | 11 |
| standard-duty lift systems, overview | 12 |
| – technical drawings | 14 |
| heavy-duty lift systems, overview | 18 |
| – technical drawings | 20 |

a chain that pulls and pushes can do the lifting as well

Linear motion technology is a challenge but at the same time it opens up a huge potential for technological innovation and economic improvement: In the manufacturing industry, wherever the logistics of workflow has to be more efficient. In any activity that has to do with the storing and the distribution of goods. Or, for example, in stage and show technology, where there are platforms to be lifted and scenery to be moved – with more aesthetic ambitions, but not with minor technical challenges.

In all these fields, demands on motion technology have been increasing constantly over the past few years. With proceeding automation and higher security standards, they will continue to increase in the future.

SERAPID provides solutions through ongoing product innovation, application-specific engineering and customer-oriented services.

SERAPID has been specializing in linear motion technology for more than 30 years. It all started with a great idea that has never failed to produce new solutions: **the SERAPID rigid pushing chain.**

a chain that is also a jack

A load can be pulled or pushed. So one uses either a chain or a jack. But chains can only pull and jacks often take up too much space. There are many other drawbacks going along with these conventional methods of transfer. But a combination of the jack and the chain, if only it could eliminate the drawbacks, would double the benefit. It would yield a means of transfer that is flexible and powerful in any application environment. In the domain of chains, in the domain of jacks, and in many further application areas as well.

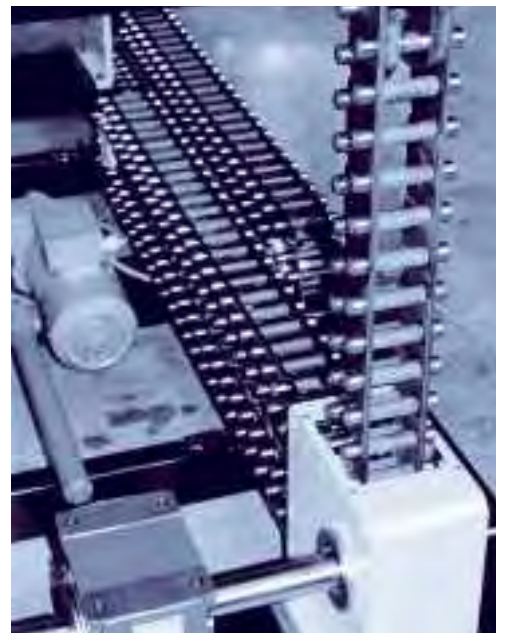

the rigid pushing chain

The SERAPID solution is as simple as it is effective. Basically, it is a chain with special links. This link features a hook-like extension which we call the shoulder. The shoulder serves as a joint between neighbouring links. When force is applied, the shoulders interlock and make the chain as rigid as a jack. At their cross-axes, the links are connected flexibly, just as in an ordinary chain. Thus, the rigid chain will still bend and can be coiled up and stored efficiently.

when push comes to lift

The SERAPID chain can push and pull, and has proven to be the superior solution in a wide variety of horizontal motion tasks. Parallel with the development of chains for horizontal transfer, we have been expanding our range of products for vertical movement. As regards the mechanical principle of the rigid chain, it makes no difference whether the load is pushed forward or upward. Of course, in addition to friction and lateral stability, one has to deal with gravity and column strength.

The differences between horizontal and vertical applications lie in the range of functions that the chain has to accomplish. Horizontal transfers involve only pushing and

pulling operations. Vertical applications, too, require pushing, but braking rather than pulling. This puts special stress on each component part and demands a special design for the entire lifting device.

In stage applications, lifts are used most of the time for holding a load rather than for bringing it up. This sets the further requirement of static capacity. And in the same domain, after all, the pulling function may come in handy again – when there are external pulling forces, for example through seismic shock or on a rolling base, such as a ship on sea. Thanks to the fact that they are basically chains, SERAPID lifts can absorb pulling forces and will remain stable even in unstable environments.

SERAPID

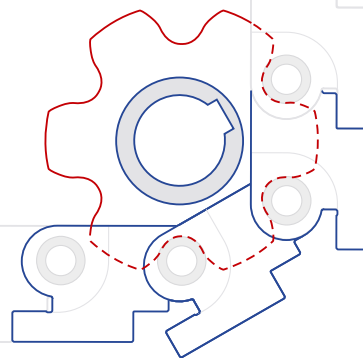

how the chain lifts a load

The SERAPID lifts are driven by means of pinions on a shaft. These are integrated in the lift drive housing. As the shaft rotates the pinions, their teeth engage with rollers on the links' cross-axes, moving the links upward or downward one by one. As each link enters its upright position on the sprocket wheel, it is locked with its preceding link and aligned on the vertical axis.

As the lift column moves out of the drive housing, it pushes the load upward along the lift path. In the other direction, when lowering the load, the pinions slow down or hold up the load against the force of gravity.

Unlike a normal chain, the lift chain does not cycle and does not need to be twice as long as the stroke. Thus, the **length required for the lift** is always the length of the stroke plus only the few addi-

SERAPID ChainLift

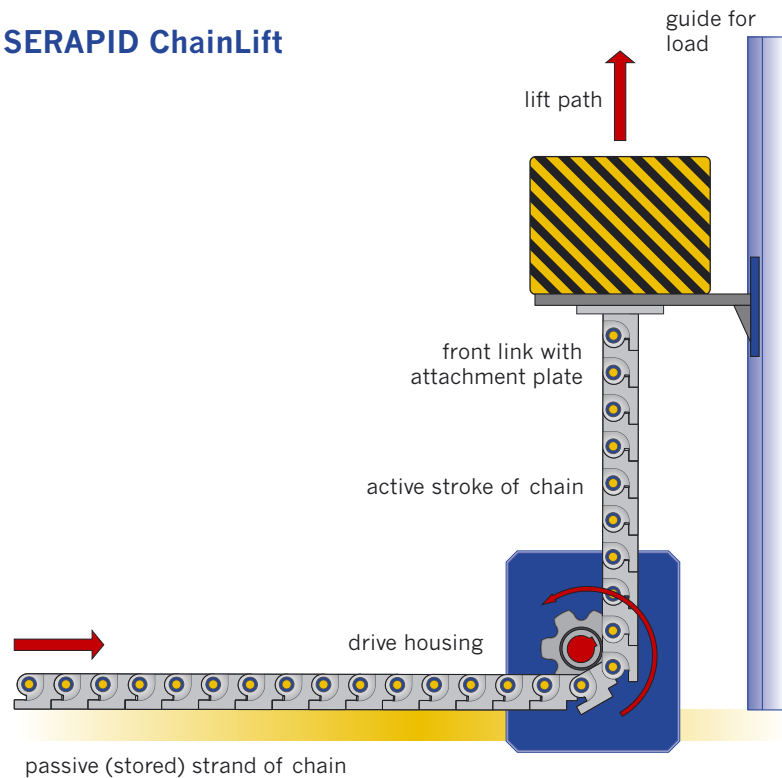

tional links that have to remain in the drive housing.

inside the lift drive

The links' course through the drive housing is defined by **guide and reaction elements**. These counter the thrust resistance and keep the lift strand on its track.

ChainLift

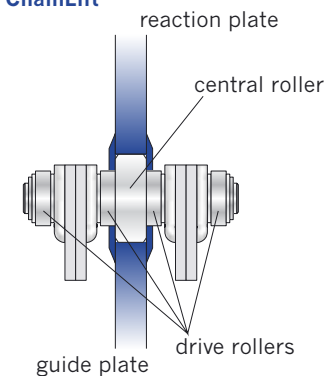

With the SERAPID ChainLift, a central roller on each link's cross-axis is guided between two plates. The LinkLift has two lines of rollers on each side; these are guided by rails inside the housing.

LinkLift

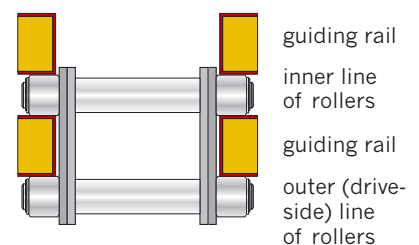

ChainLift and LinkLift

SERAPID offers two types of vertical chains and thus two types of lift systems. One, the **ChainLift**, uses a chain that is basically the same as the chain used in horizontal applications. For vertical use, the chain has been modified mostly in the guide and reaction mechanics, with bigger and broader central rollers and thicker guide and reaction plates.

The second type of SERAPID lift system, the **LinkLift**, uses a newly developed concept of the rigid chain. It features links that are shaped like building blocks and stack up to a tower at the output side of the drive.

The new links consist of two facing steel plates and are interconnected by **two rows of cross-axes**. These axes have rollers on their outer ends which are used for moving, driving and guiding the lift strand.

The axes in one of the rows connect the links permanently, but flexibly, so they still rotate. The axes in the other row only help to prop up the links against each other; they engage with notches in the side plates of neighbouring links. These

connections are opened when the strand is redirected or coiled. Under the load, however, they are fixed and so lock the entire active lifting column. In addition, the cassette-like shape and the boxing of inner and outer links contribute to the column's stability. All factors together make for a **closed formation** with high rigidity and strength.

elementary conditions

To ensure proper operation of the entire lift system, certain conditions have to be met.

Guiding the load over the entire lifting distance secures the locking of links.

The load platform has to be positioned at a right angle and fixed to the lift without any play. This is ensured with the lift's special front link and attachment plate.

The drive housing has to be fixed to the base firmly without any play and in parallel alignment with the attachment plate. The entire system has to be set up in perpendicular orientation, with the lifting column perfectly vertical and the inactive strand perfectly horizontal.

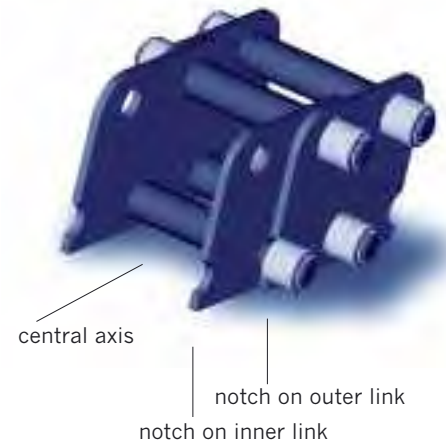

The LinkLift's patented locking mechanism:

Links are boxed into one another. The central axis connecting the side plates of one link engages with notches on the plates of the adjoining links.

SERAPID LinkLift

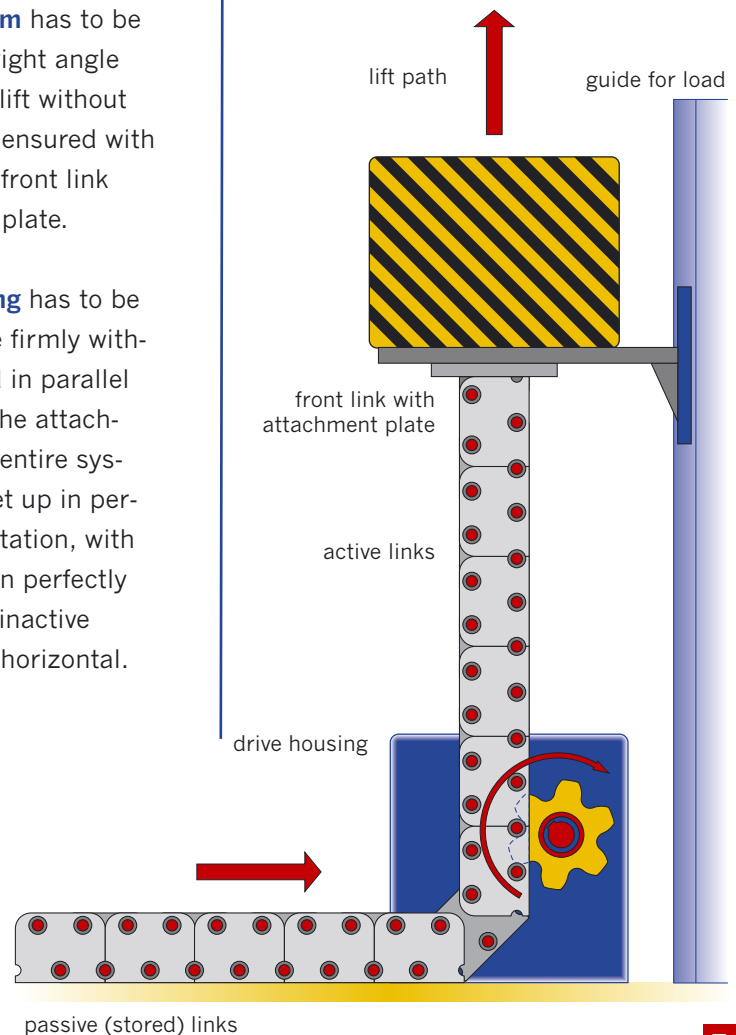

system configuration

Several lift columns can be combined into one array, and be driven synchronously with only one motor. Several such arrays may in turn be combined for practically any platform or load size and shape. In general, the system layout is flexible and easily adaptable to the individual application environment.

Columns in one line: The array may consist of only one column, or of two in line. If guide rails cannot be put on all four corners, the guiding element must be long enough to prevent tilting of the load.

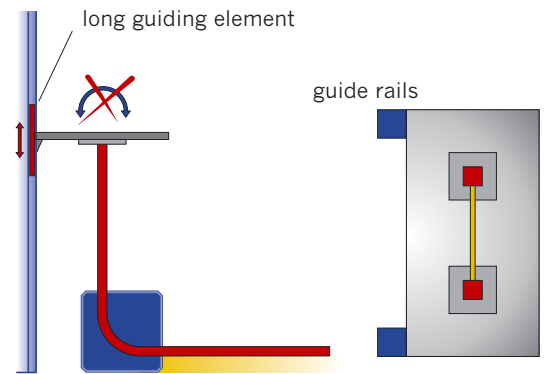

basic configurations

Lift columns that are connected to the same drive are usually arranged in one or two lines, as required by the dimensions of the load. Except for lifting tables that have their own structure to secure the lift's proper course, all configurations require the load platform to be guided externally along the entire lifting distance. At least two guides are required to balance the lift. Large loads or specially shaped platforms may require additional guides.

The total force that has to be applied to the load is distributed on the columns of the lift array.

To plan your system, use the drawings provided in this brochure. Download drawings in DXF format from www.serapid.com

Columns in two lines: At least three columns are required. The line positions can be offset against each other

to utilize the space under the platform for economical storage of the lift return.

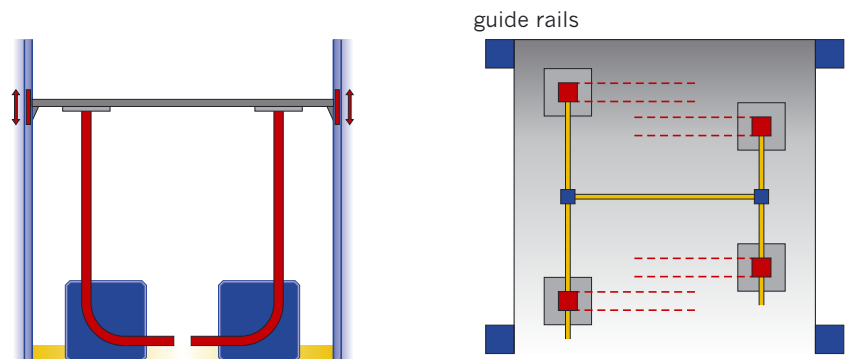

Lifting table with collapsible structure: The load may be supported by a mechanically expanding structure that defines the vertical movement. For example, with a table on

scissors-legs, the lift-side ends of the scissors are fixed while their opposites move along a clearly defined path. – This type of lift usually has one or two columns.

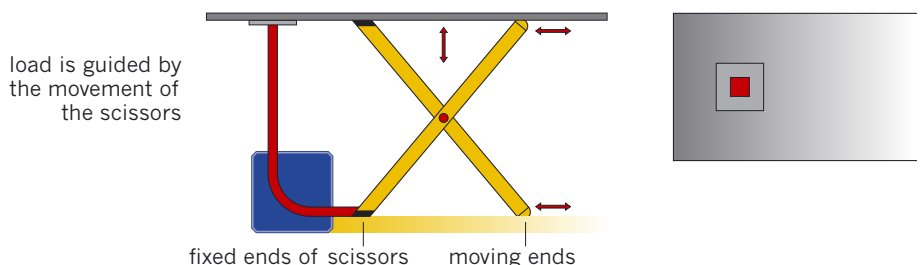

possibilities of storage

Both the ChainLift and the LinkLift are stored horizontally on the base. No special magazine is required; however, the lift return must be supported by a solid base. The LinkLift comes with a re-

turn guide rail. The return strand can be looped once, which reduces the storage space by one half. A pair of sprocket wheels is inserted into the loop to guide the lift smoothly around the bend. The wheels move forward and backward with the

strand as the lift goes up or down.

The return-loop option is not available for our heavy-duty systems.

SERAPID ChainLift

SERAPID LinkLift

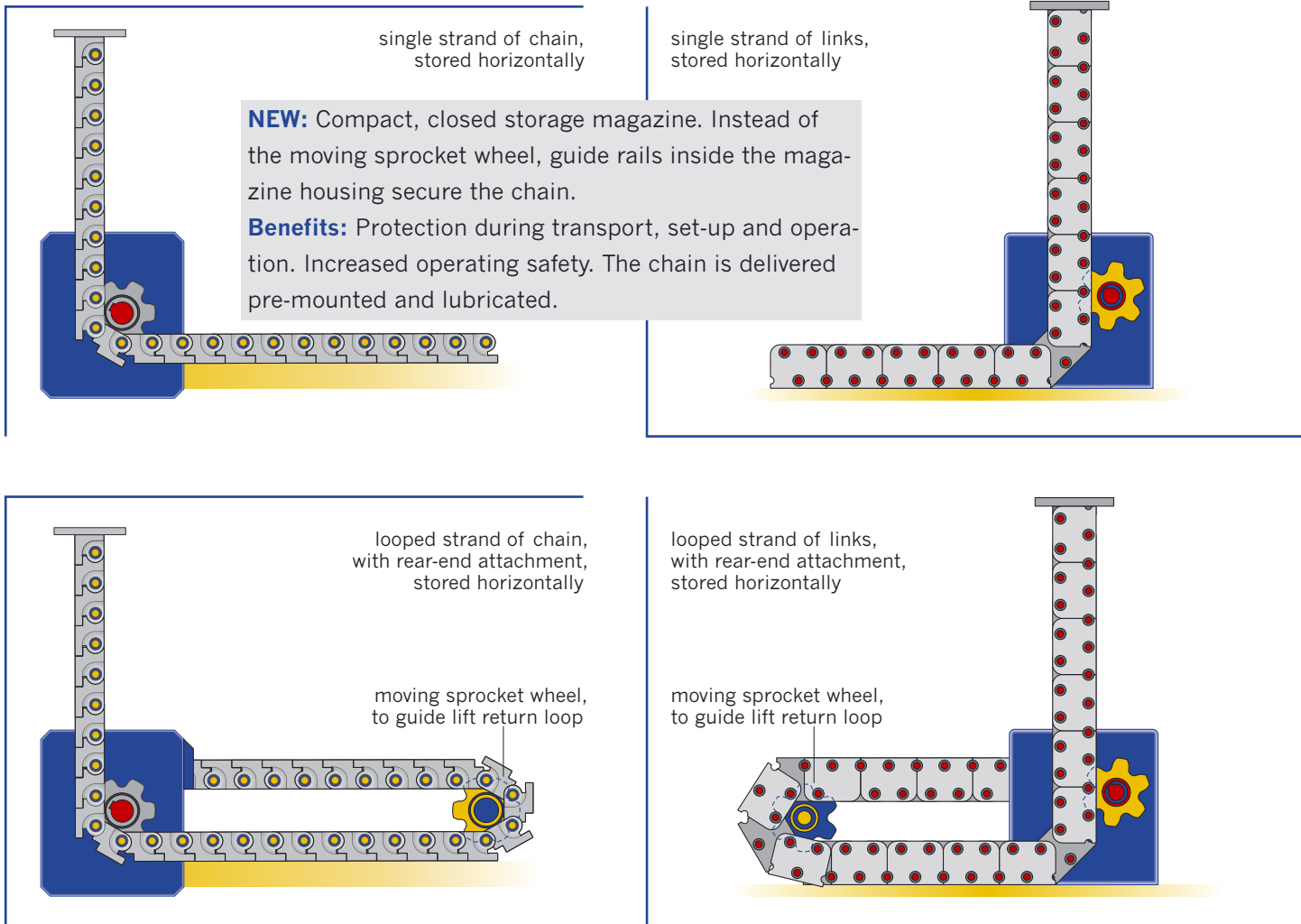

custom storage configurations

It is possible to redirect the lift return to other positions than the ones shown above. In many cases that seem to

be difficult at first, a solution can still be found. Or existing space can be used more efficiently. – Ask SERAPID Engineering if you cannot use one of the standard storage methods.



calculating thrust force and drive power

To select the appropriate lift type for your application, you need to know the total thrust force that will be applied to the lift system. Moreover, this force has to be known to calculate the drive output power required.

thrust force

The **total force**, F_t , which is to be applied to the lift (all strands) is the sum of the load's weight force, the friction force, acceleration or deceleration forces and external forces.

$$F_t = F_w + F_f + F_a + F_e \text{ [N]}$$

The **weight force**, F_w , is calculated by multiplying the load's mass (in kg) by the gravity constant:

$$F_w = M \times 9.81 \text{ [N]}$$

Note that the weight force must include the **weight of the platform and/or supporting structures**. For strokes greater than 3 m, the weight of the lift strands has to be included as well.

The **friction force**, F_f , chiefly depends on the surface properties of the guiding ele

ments. It is obtained by multiplying the relevant share of the weight force by the friction factor for the guiding.

Acceleration and/or deceleration forces, F_a , have to be considered according to the individual application.

External forces, F_e , may occur through shock loads, for example, when the lift hits a mechanical stop.

The force applied to **each single lift column** is obtained by dividing the total force by the number of columns.

drive power

To calculate the motor power required, the drive moment and revolutions per minute (rpm) must be known.

The **drive moment** M is calculated on the basis of the total thrust force:

$$M = \frac{F_t \times 10^{-3} \times p}{0.8} \text{ [Nm]}$$

– where F_t is the total of all forces in effect (see above), p is the pitch of the lift in mm and 0.8 is a constant that takes account of system efficiency.

The number of **drive revolutions**, R , is calculated on the basis of required speed:

$$R = \frac{\bar{S}}{6 \times 10^{-3} \times p} \text{ [rpm]}$$

– where \bar{S} is the motion speed in m/min, 6 is the number of pinion teeth and p is the pitch of the lift in mm.

The required **output power** P can be obtained with the formula:

$$P = \frac{M \times R}{9550} \text{ [kW]}$$



calculating the length of the lift strands

The length of a lift strand is basically the length of the stroke plus the few additional links that remain inside the drive housing and, if required, the links used for looping the return and attaching its rear end to the housing.

If there is a distance between the drive housing and the load's start position, the length of that blind stroke, B , has to be added to the actu-

ally used stroke, U . The total length of the strand is usually specified by the number of links. This number, L , is obtained by:

$$L = \frac{B + U}{p} + L_c + L_r \text{ [links]}$$

– where p is the pitch of the links. L_c is the number of links that remain in the drive housing; it is 5 for the ChainLift and 4 for the LinkLift. L_r is the number of links used for the optional

return loop and end attachment; it is 9 for the ChainLift and 8 for the LinkLift. – If necessary, the result has to be rounded to the next higher integer.

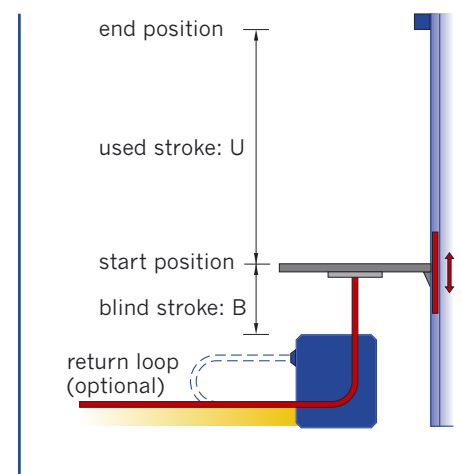

standard-duty and heavy-duty lift systems

Following the requirements of current applications, SERAPID offers two lines of lifting systems. On the one hand there is a wide range of tasks where lifts perform no more than 10 lifting/lowering cycles in one hour, while for the rest of the time they are used only to hold a load or are not used at all. For these applications we offer our **standard-duty lift systems**.

On the other hand, there are tasks that require 20 or even more active operating cycles per hour – especially in industrial production. To ensure increased lifetime and reliability for such applications, we have devised our line of **heavy-duty lift systems**. Among other special features, these include reinforced components and permanent lubrication systems.



standard-duty lift systems

The line of standard-duty lifts is suitable for applications with up to 10 duty cycles per hour. This includes most industrial warehousing applications, most stage and platform lifting applications and many others.

This product line offers lift columns with a **dynamic capacity** of up to 50 000 N and a **static capacity** of up to 100 000 N.

Static capacity is relevant in particular to stage applications. While the dynamic process of lifting puts stress chiefly on the drive elements, the static holding of a load, above all, requires high column stability and axis resistance. For the **ChainLift**, the static and the dynamic capacity are the same, due to the structural properties of the chain. The **LinkLift**, however, allows static loads

up to twice the maximum dynamic load, thanks to its special construction.

Standardly, the **maximum stroke length** is 7 m. Longer strokes can be obtained by guiding the lift columns. Contact SERAPID Engineering for pertinent information.

| SERAPID standard-duty lift systems | | | | |
|------------------------------------|--------------|--------------|-------------|--------------|
| | ChainLift 40 | ChainLift 60 | LinkLift 50 | LinkLift 100 |
| pitch of link (mm) | 40 | 60 | 50 | 100 |
| max. stroke (m) | 1 | 2 | 3 | 7 |
| max. static force (N) | 7 500 | 20 000 | 30 000 | 100 000 |
| max. dynamic force (N) | 7 500 | 20 000 | 15 000 | 50 000 |
| nominal speed (mm/s) | 200 | 200 | 200 | 200 |

available options

The following options are available for our standard-duty products:

mounting flange for gear motor

looped return with sprocket and rear-end attachment

special shaft output to allow integration of **encoder or CAM switch** by the user

double output drive shaft

special output shaft, custom design as required



capacity specifications

The chart below shows the capacities of the standard-duty lifts relative to the stroke height. The corresponding fields represent the recommended application domain for each of the products.

The specifications are given for the **unguided use** of the lifts. Moreover, they are valid only for the nominal speed of 200 mm/s and a maximum of 10 cycles per hour. Also, the capacities can only be guaranteed if the mounting tolerances (see the technical drawings) are observed.

The capacity specifications include security margins according to application-relevant standards.

NEW:

LinkLift 80

35 kN dynamic,
70 kN static capacity
stroke up to 5 m

LinkLift 30

10 kN dynamic,
20 kN static capacity
stroke up to 2 m

See attached data sheet.

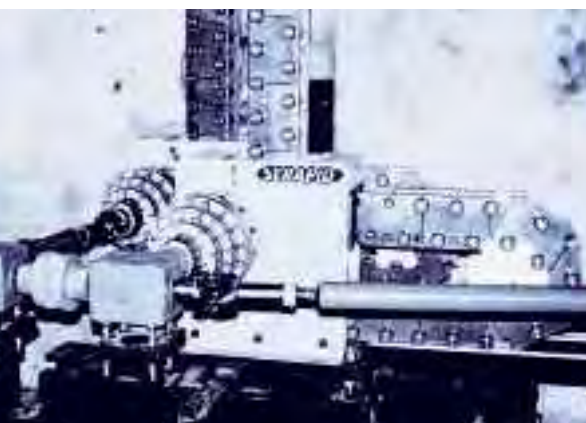
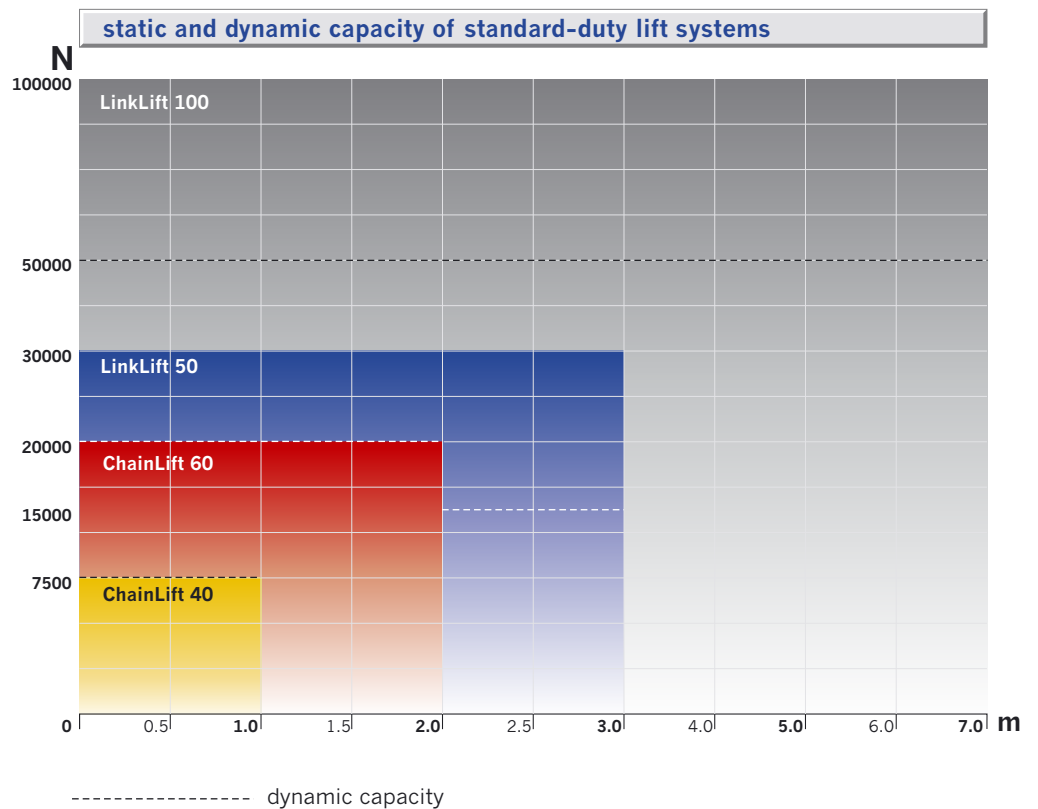

If your application does not fall within the specifications, ask SERAPID Engineering for your custom solution.

standard-duty lift systems

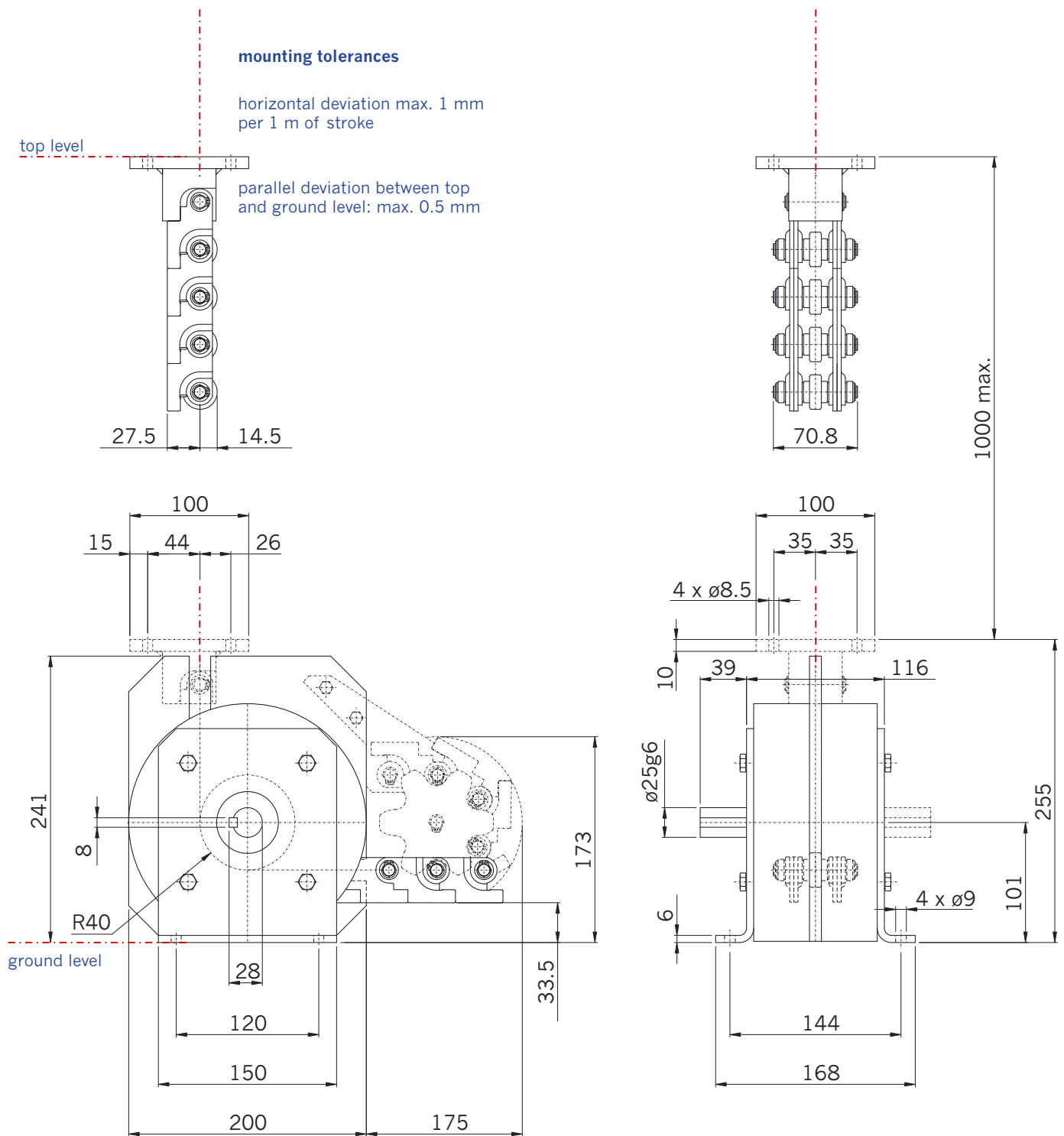

all dimensions in mm

ChainLift 40

| | |
|-------------------------|---|
| pitch of link (mm) | 40 (equal to segment radius of drive pinions) |
| chain weight per m (kg) | 7.8 |
| drive housing | cast steel, 90°, extended guide plate, weight 15 kg |
| max. stroke (m) | 1 |
| max. dynamic force (N) | 7 500 |
| max. static force (N) | 7 500 |
| nominal speed (mm/s) | 200 |

NEW: Compact, closed storage magazine. Instead of the moving sprocket wheel, guide rails inside the magazine housing secure the chain.

Benefits: Protection during transport, set-up and operation. Increased operating safety. The chain is delivered pre-mounted and lubricated.

SERAPID

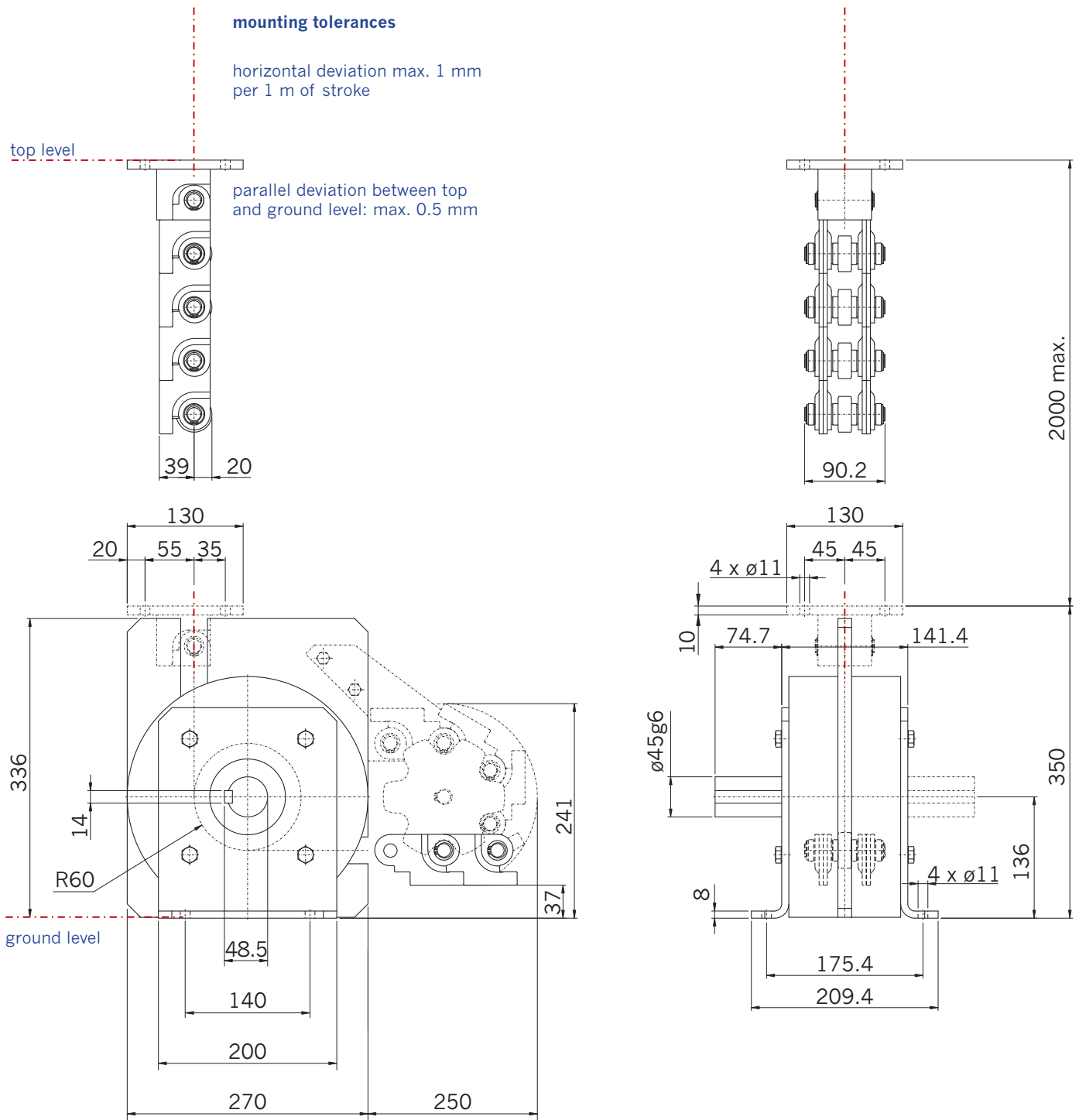

all dimensions in mm

ChainLift 60

| | |
|-------------------------|---|
| pitch of link (mm) | 60 (equal to segment radius of drive pinions) |
| chain weight per m (kg) | 10.5 |
| drive housing | cast steel, 90°, extended guide plate, weight 45 kg |
| max. stroke (m) | 2 |
| max. dynamic force (N) | 20000 |
| max. static force (N) | 20000 |
| nominal speed (mm/s) | 200 |

standard-duty lift systems

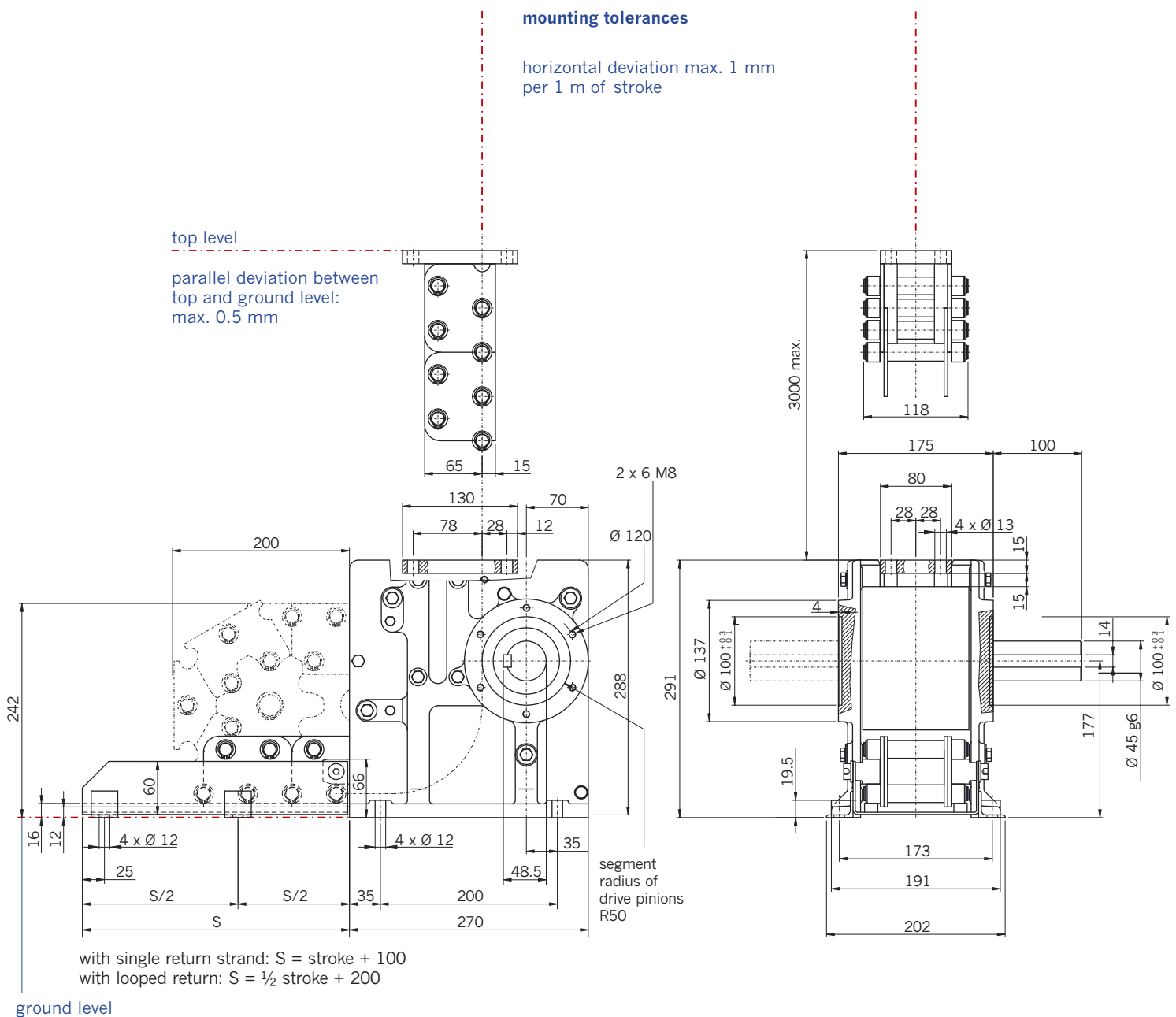

all dimensions in mm

LinkLift 50

| | |
|-------------------------|--|
| pitch of link (mm) | 50 (equal to segment radius of drive pinions) |
| chain weight per m (kg) | 18 |
| drive housing | cast steel, 90°, lateral guide rails, weight 30 kg |
| max. stroke (m) | 3 |
| max. dynamic force (N) | 15 000 |
| max. static force (N) | 30 000 |
| nominal speed (mm/s) | 200 |

NEW: Compact, closed storage magazine. Instead of the moving sprocket wheel, guide rails inside the magazine housing secure the chain.

Benefits: Protection during transport, set-up and operation. Increased operating safety. The chain is delivered pre-mounted and lubricated.

SERAPID

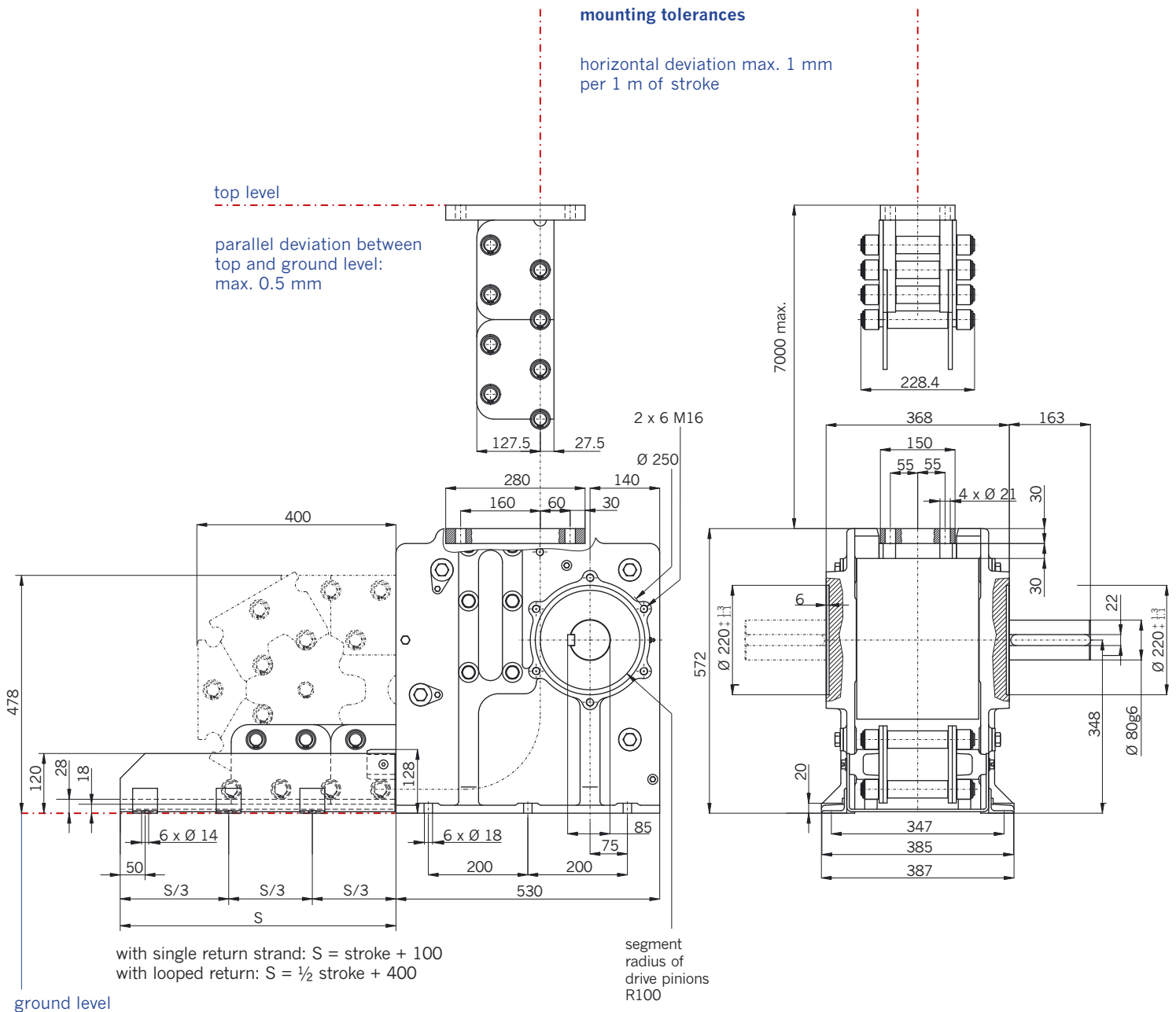

LinkLift 100

| | |
|--------------------------------|---|
| pitch of link (mm) | 100 (equal to segment radius of drive pinions) |
| chain weight per m (kg) | 67 |
| drive housing | cast steel, 90°, lateral guide rails, weight 240 kg |
| max. stroke (m) | 7 |
| max. dynamic force (N) | 50 000 |
| max. static force (N) | 100 000 |
| nominal speed (mm/s) | 200 |

heavy-duty lift systems

The line of heavy-duty lifts is laid out for especially high cycling rates and continuous operation. It has been designed chiefly for application in the manufacturing industry. The guaranteed minimum lifetime is **1 million duty cycles** under maximum load, **provided SERAPID's operating conditions are followed.** (See graph below.)

All types include a permanent lubrication system, with oil-proof drive housing and storage magazine.

This product line is comprised of four types of **HD Lift** systems. It covers dynamic and static capacities up to 50000 N and stroke heights up to 2.5 m.

The diagram below shows the graphs of product lifetimes relative to applied forces. Depending on conditions of use, it may be more cost-effective to opt for a stronger type of lift than would be required for the load. The higher lifetime may make it the more economical choice.

lifetime of heavy-duty lift systems relative to applied force

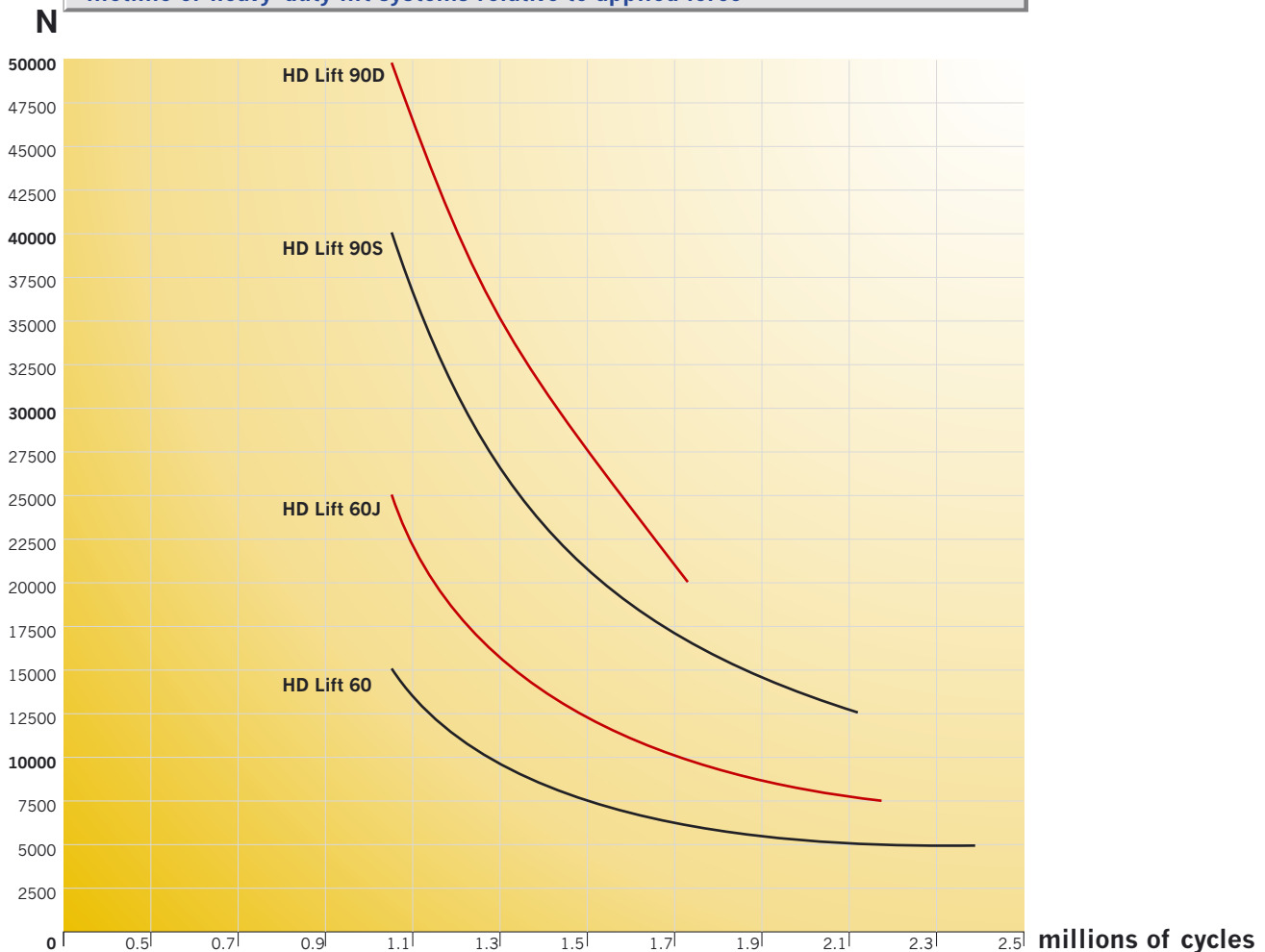

capacity specifications

The table below shows the types of SERAPID heavy-duty lifts. The chart shows their (dynamic and static) capacities relative to the stroke height. The corresponding fields represent the recom-

mended application domain for each product.

The specifications are given for the **unguided use** of the lifts. Moreover, they are valid only for the nominal speed of 300 mm/s. Also, the capacities can only be guaranteed

if the mounting tolerances (see technical drawings) are observed.

If your application does not fall within the specifications, ask SERAPID Engineering for your custom solution.

| SERAPID heavy-duty lift systems | | | | |
|---------------------------------|------------|---------------|-------------|-------------|
| | HD Lift 60 | HD Lift 60J | HD Lift 90S | HD Lift 90D |
| pitch of link (mm) | 60 | 60 (2 chains) | 90 | 90 |
| max. stroke (m) | 1.5 | 1.5 | 2 | 2.5 |
| max. static force (N) | 12 500 | 25 000 | 40 000 | 50 000 |
| max. dynamic force (N) | 12 500 | 25 000 | 40 000 | 50 000 |
| nominal speed (mm/s) | 300 | 300 | 300 | 300 |

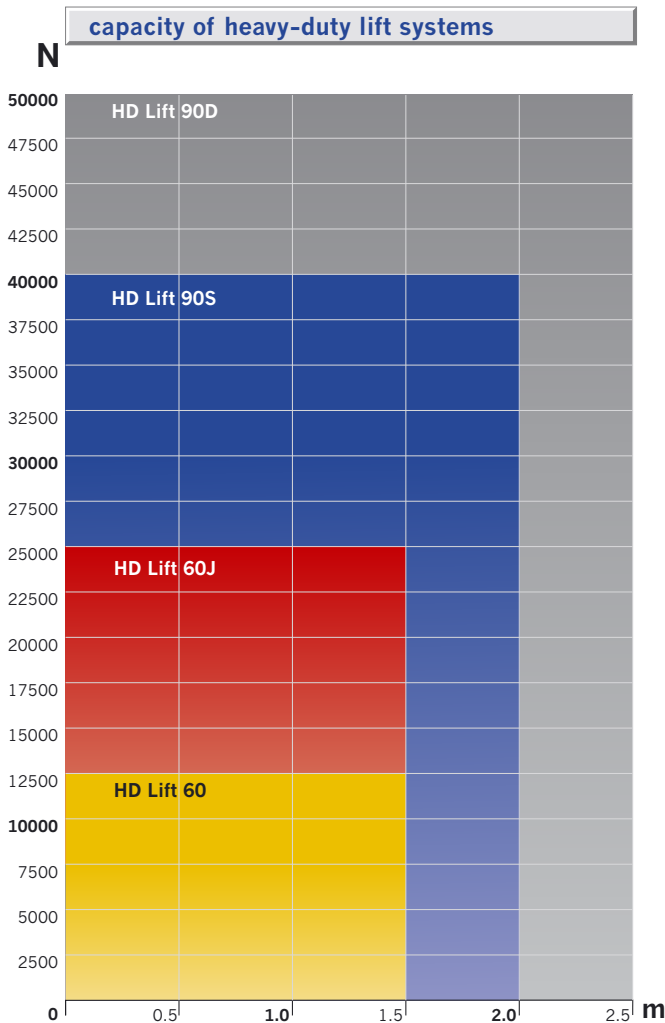

available options

The following options are available for our heavy-duty products:

mounting flange for gear motor

special shaft output to allow integration of **encoder or CAM switch** by the user

double output of drive shaft

special output shaft, custom design as required



mounting tolerances

horizontal deviation max. 1 mm
per 1 m of stroke

top level

parallel deviation between
top and ground level:
max. 0.5 mm

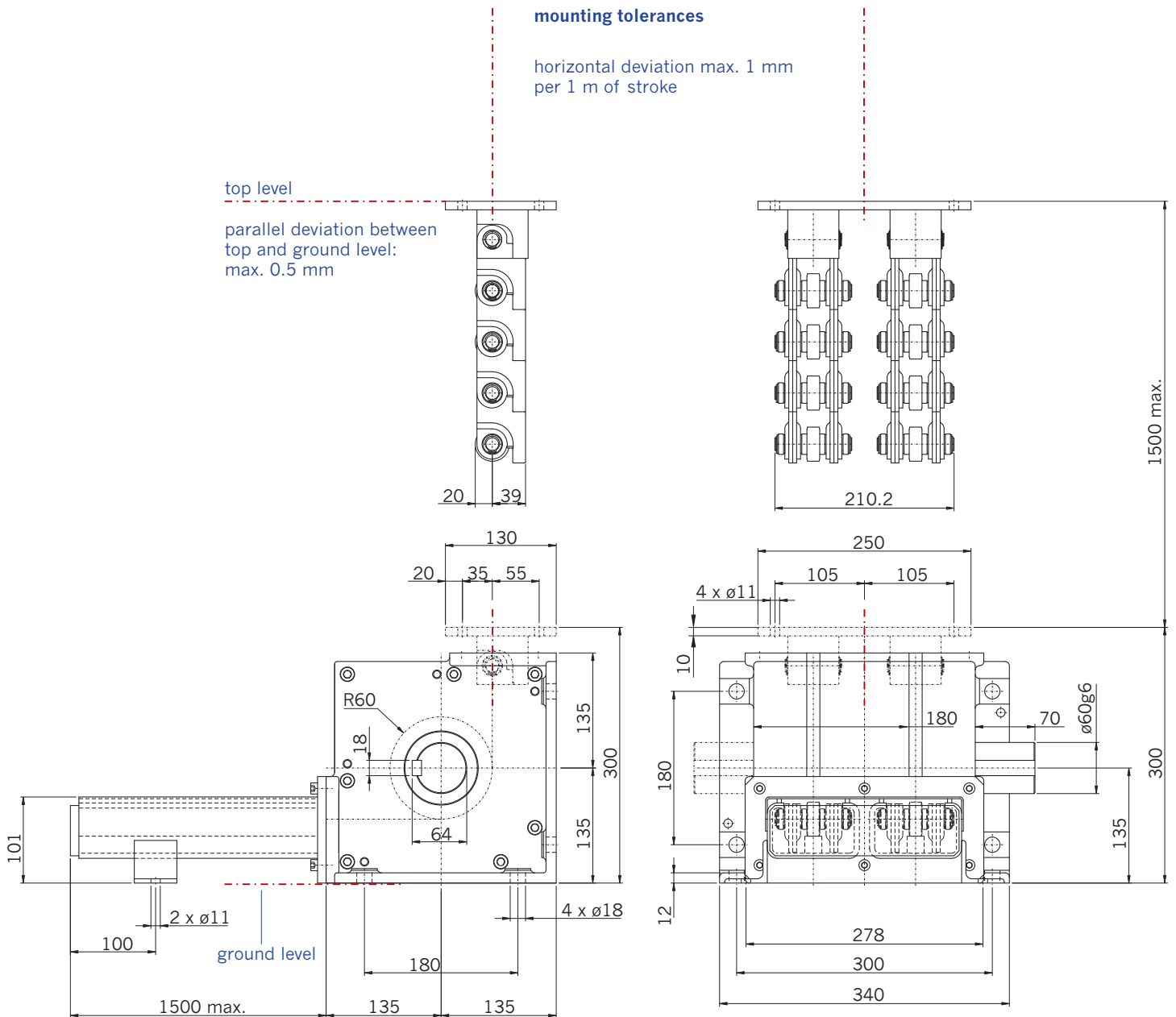

all dimensions in mm

HD Lift 60J

| | |
|-------------------------|--|
| pitch of link (mm) | 60 (equal to segment radius of drive pinions), 2 chains |
| chain weight per m (kg) | 2 x 10.5 |
| drive housing | cast steel, 90°, standard guide and reaction plates, oil-proof |
| max. stroke (m) | 1.5 |
| max. dynamic force (N) | 25 000 |
| max. static force (N) | 25 000 |
| nominal speed (mm/s) | 300 |

heavy-duty lift systems

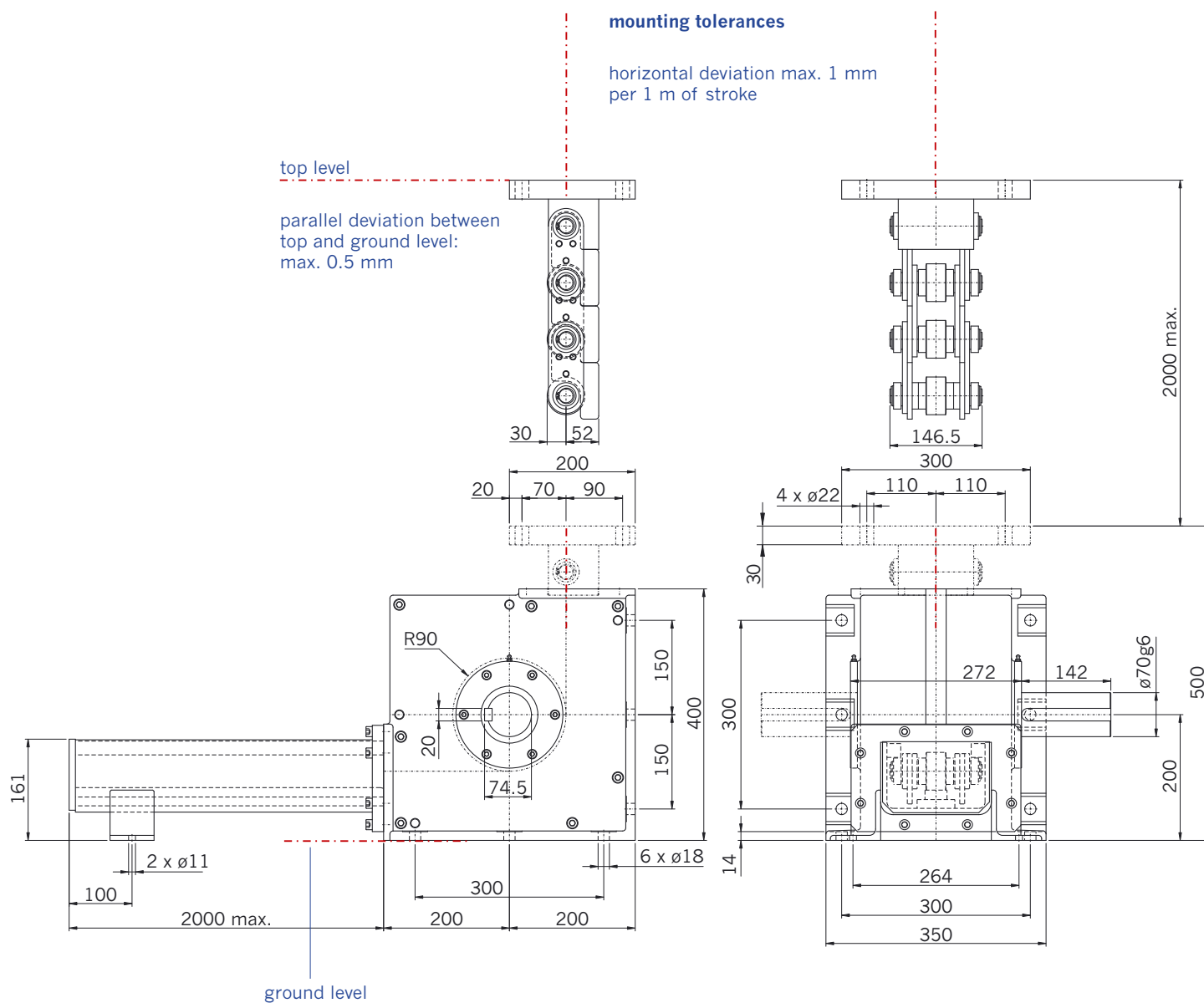

all dimensions in mm

HD Lift 90S

| | |
|-------------------------|--|
| pitch of link (mm) | 90 (equal to segment radius of drive pinions) |
| chain weight per m (kg) | 31 |
| drive housing | cast steel, 90°, standard guide and reaction plates, oil-proof |
| max. stroke (m) | 2 |
| max. dynamic force (N) | 40 000 |
| max. static force (N) | 40 000 |
| nominal speed (mm/s) | 300 |

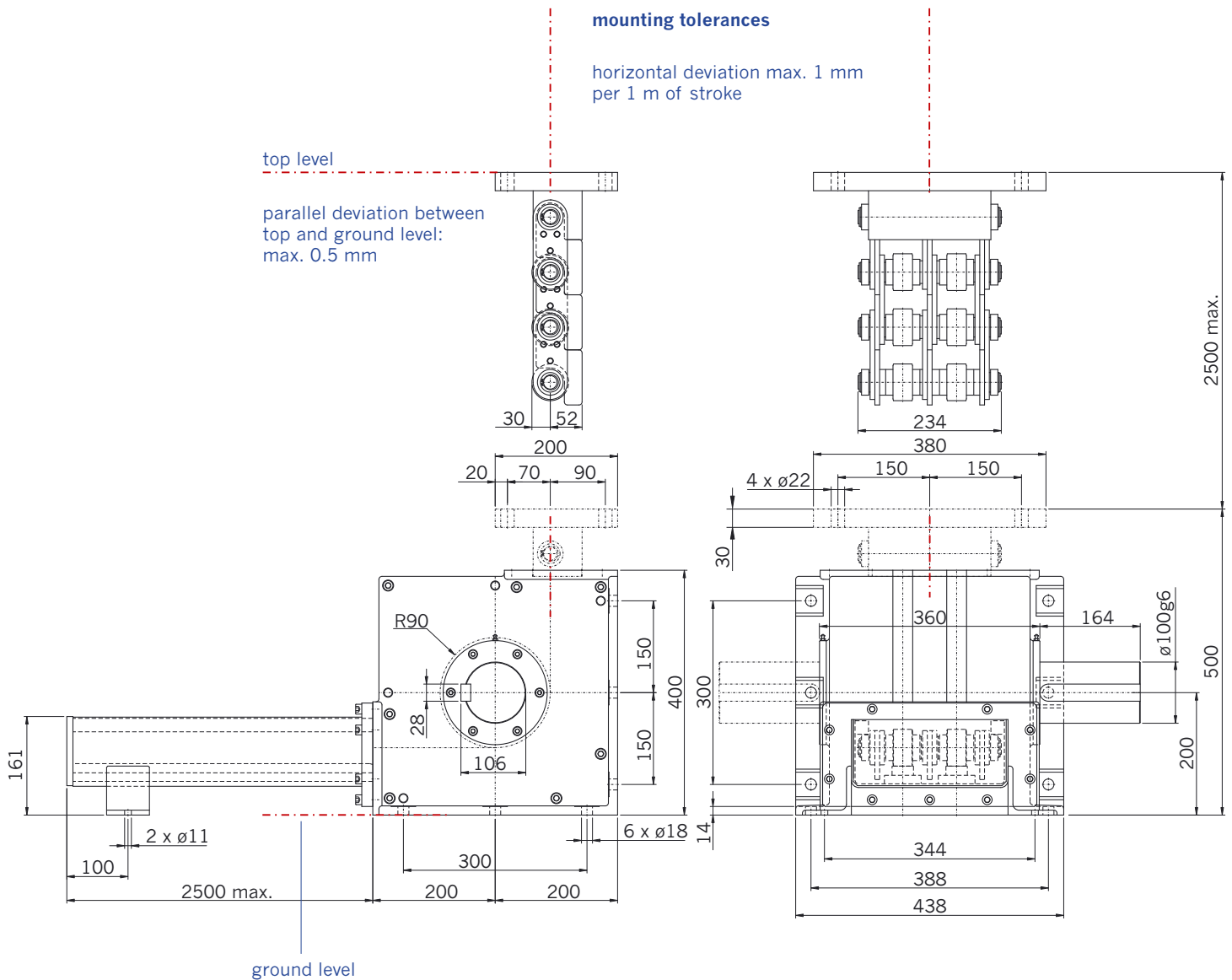

all dimensions in mm

HD Lift 90D

| | |
|-------------------------|--|
| pitch of link (mm) | 90 (equal to segment radius of drive pinions) |
| chain weight per m (kg) | 49 |
| drive housing | cast steel, 90°, standard guide and reaction plates, oil-proof |
| max. stroke (m) | 2.5 |
| max. dynamic force (N) | 50 000 |
| max. static force (N) | 50 000 |
| nominal speed (mm/s) | 300 |

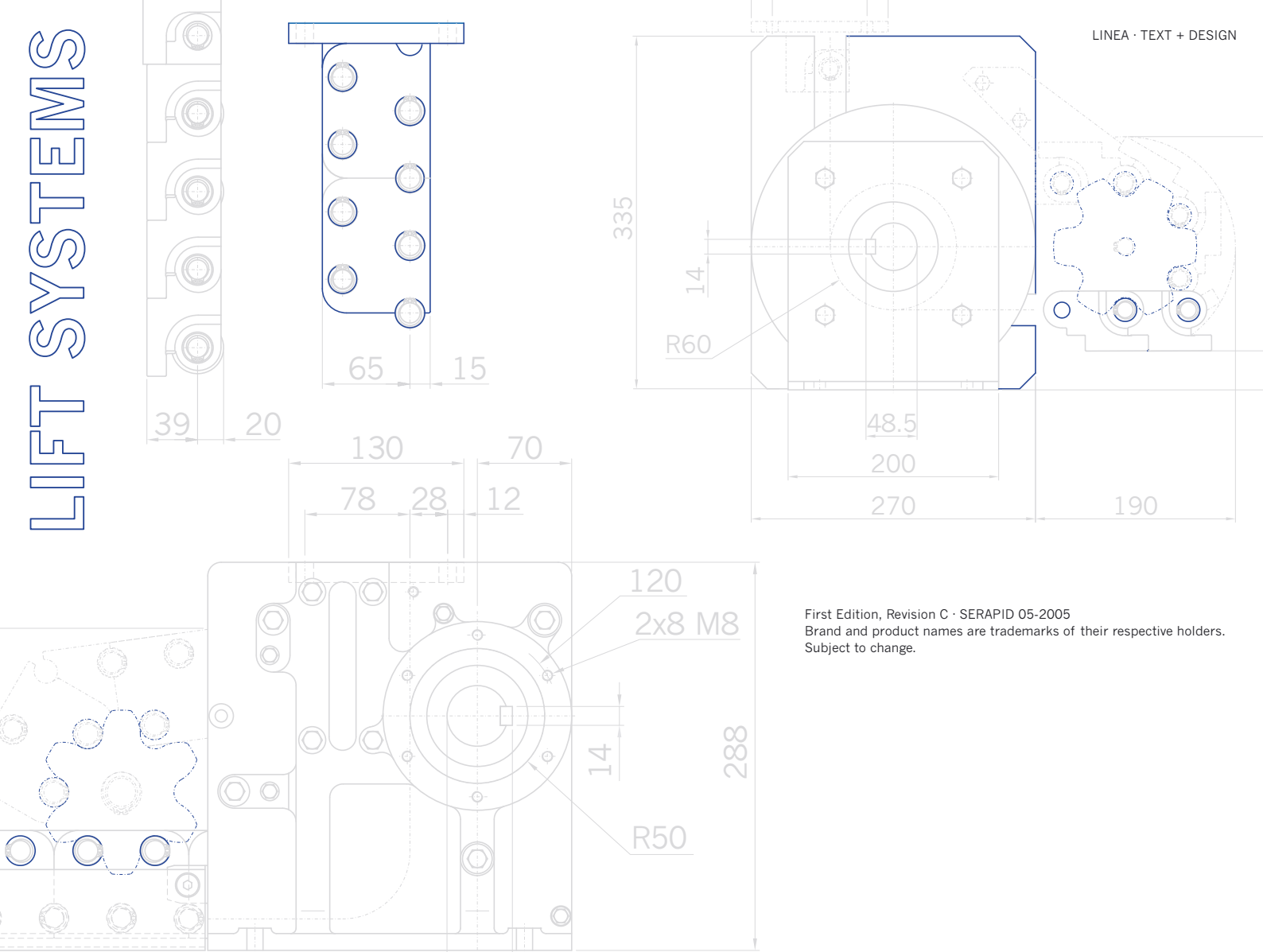

First Edition, Revision C · SERAPID 05-2005
 Brand and product names are trademarks of their respective holders.
 Subject to change.

SERAPID representative

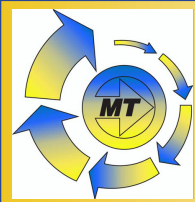

www.serapid.com

www.motiontech.com.au

France · United Kingdom · Germany · Austria · Switzerland · Belgium ·
 Luxembourg · Spain · Italy · The Netherlands · Denmark ·
 Sweden · Finland · Norway · USA · Japan



Distributed in Australia and New Zealand By:



Distributors for Australia & New Zealand

MOTION TECHNOLOGIES PTY LTD

24/22-30 Northumberland Road
 Caringbah NSW 2229 Australia
 Phone: (02) 9524 4782
 Fax: (02) 9525 3878

sales@motiontech.com.au
www.motiontech.com.au

© 21/03/19

SERAPID USA INC.

5400 18 Mile Road
 Sterling Heights MI 48314, USA

Phone +1 586 274 0774
 Fax +1 586 274 0775

info-us@serapid.com