



Precision in the Extreme



www.motiontech.com.au

IncOder

IncOder™ Product Guide Maxi Range Inductive Angle Encoders



MAXI Revision 4.11.3 September 2017

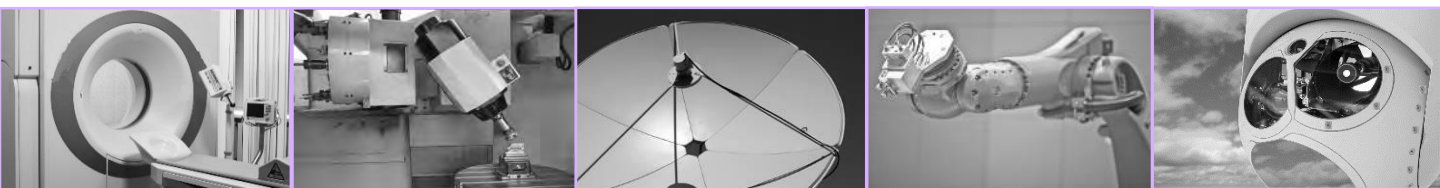



Precision in the Extreme

- No contacts
- No bearings
- No couplings
- No maintenance
- Absolute
- Compact
- Easy installation
- Accurate
- Robust
- Integral electronics
- >200 Million product options
- Economical
- Global support

.....they tick all the boxes.



1. Introduction	4
2. Manufacturing & Quality	6
3. Mechanical Format Data	7
3.1 Main Dimensions	7
3.2 Installation Guide	8
3.3 Radial Connections	9
3.4 Integral Axial Cable	14
3.5 Extended Product Range	16
3.6 Measurement, Electrical & Environmental Data	18
4. Communication Interfaces	19
4.1 Output Resolution	19
4.2 Multi-Turn or Single Turn	19
4.3 Zero Point, Zero Set & Zero Reset for Digital Outputs	19
4.4 Synchronous Serial Interface - Product Options SSI1-SSI9	20
4.5 Asynchronous Serial Interface - Product Option ASI1-2	23
4.6 Serial Peripheral Interface - Product Option SPI1	24
4.7 BiSS-C Interface - Product Option BIS1	26
5. Connector Diagrams	27
6. Product Ordering	28
7. Customised Products	30
8. Accessories	31
9. Frequently Asked Questions	32
10. Contact	35

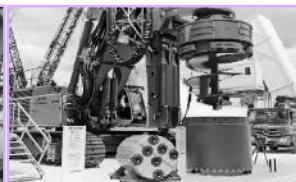

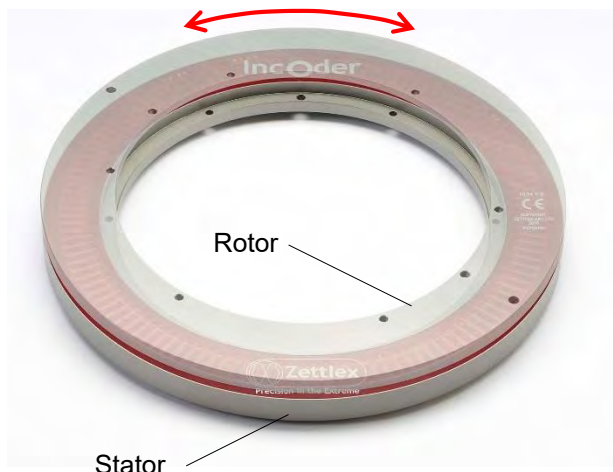

IncOder technology is proven – tried and tested in tough conditions on land, sea and in the air. There is no need for service or maintenance - IncOders are 'fit and forget' devices.

They are designed and built so they won't let you down when the going gets tough.

IncOders make it easy to achieve high precision, high reliability angle measurement. There is no need to consider bearing alignment, seals or wearing parts.

Whereas optical or capacitive sensors can be unreliable in harsh conditions, IncOders are generally unaffected by foreign matter and IP68 rated versions are available. Unlike capacitive devices, there is no need to earth the Rotor or Stator. Robust, hard-anodized aluminium alloy housings and monolithic constructions are used throughout.

The Stator contains all the electronics to receive power and output a signal, showing the angle of the Rotor relative to the Stator. IncOders are truly absolute which means that they need no motion at power up to determine position. Compliant or special couplings are not required, so the Rotor & Stator can simply be fixed directly to the host product. Precise mechanical mounting is not necessary to achieve high measurement performance and there are no bearings. The measurement performance stated in this Product Guide is guaranteed provided that the IncOder is installed as per its installation tolerances.

IncOders have a solid track record in demanding applications such as industrial machinery, armoured vehicles, unmanned systems, naval and marine equipment. IncOders are designed and built in ISO-9001 accredited facilities in the UK; contain no ITAR components and do not need an export licence unless they are >1000mm diameter.

Zettlex IncOders are non-contact devices for precise angle measurement. They use an inductive technique, similar to that used by electrical transformers. IncOders may be considered as an inductive encoder.

IncOders are well suited to harsh environments - where potentiometers, optical or capacitive devices might be unreliable.

IncOders have two main parts each shaped like a flat ring: a Stator and a Rotor. The Stator is powered and measures the angular position of the passive Rotor.

A big bore and low axial height allows easy integration with through-shafts, slip-rings, direct drive motors, optical-fibres, pipes or cables.



The IncOder range offers millions of options. **Specify the right product for your application using the IncOder Product Option / Part Number (see Section 6).** Each IncOder contains one Stator and one Rotor. Other than the 595mm IncOder, Stators & Rotors are not matched pairs – in other words, either element may be swapped out for replacement, if necessary. The range of options are:-

IncOder Size : stated as outer diameter: 325, 379, 429, 595mm – see Section 3.

Resolution Options : 10 to 22bits - see Section 4.

Communication Interface Options:

Synchronous Serial Interface – see Section 4.4 for various formats (Product Options SS11-9)

Asynchronous Serial Interface – see Section 4.5 (Product Option AS11-2)

Serial Peripheral Interface – see Section 4.6 (Product Option SPI1)

BISS-C – see Section 4.7 (Product Options BIS1)

Connection Options : radial & axial connections as well as integral cables – see Section 3.3-3.4 & 5.

Voltage Options : 5, 12 or 24VDC.

Extended Range Options : these options are only intended for ultra high-reliability applications which may require extended thermal stress screening, bake-out, high shock/vibration constructions, use of conductive surface finishes, leaded solder, low or high operating temperatures – see Section 3.5.

A range of Accessories is also available (see Section 8) including:

Cables : various shielded cables with connector.



IncOders are designed, made, tested and shipped by Zettlex's facility in Cambridge, UK. Support is provided by the same site or by our global network of partners.



IncOder manufacturing is well established, having been perfected over years and the production of thousands of products. Every IncOder is serial numbered and tested according to a rigorous acceptance test procedure before dispatch. Detailed test records for every IncOder are stored by Zettlex.



Certificates of conformity are available as well as a RoHS compliance certificate and a REACH statement. IncOders are not ITAR restricted and use no ITAR components. A UK government export license is typically not required for the devices specified in this Product Guide.

All design, manufacturing and commercial processes operate under a comprehensive ISO-9001:2008 quality management system. The quality management system is subject to regular internal and external audit – including an annual audit by a UKAS accredited, independent authority. Zettlex is also certified for the design and manufacture of intrinsically safe (ATEX) sensors under BS EN 13980. Electronics manufacturing is to IPC Class III standards.

A copy of our ISO-9001 and ATEX certificate is available on www.zettlex.com.



3.1 Main Dimensions – External Mount Stator & Screw Mount Rotor – Product Option INC-13

NOTES

1. 3D CAD IGES FILES AVAILABLE ON WWW.ZETTLEx.COM
2. ALL DIMS IN mm – DO NOT SCALE
3. 3RD ANGLE PROJECTION
4. VIEW SHOWN WITH AXIAL CONNECTOR (AC1)
5. UNLESS STATED, TOLERANCES:-
 0 DECIMAL PLACES = ± 0.5
 1 DECIMAL PLACES = ± 0.2
 2 DECIMAL PLACES = ± 0.1

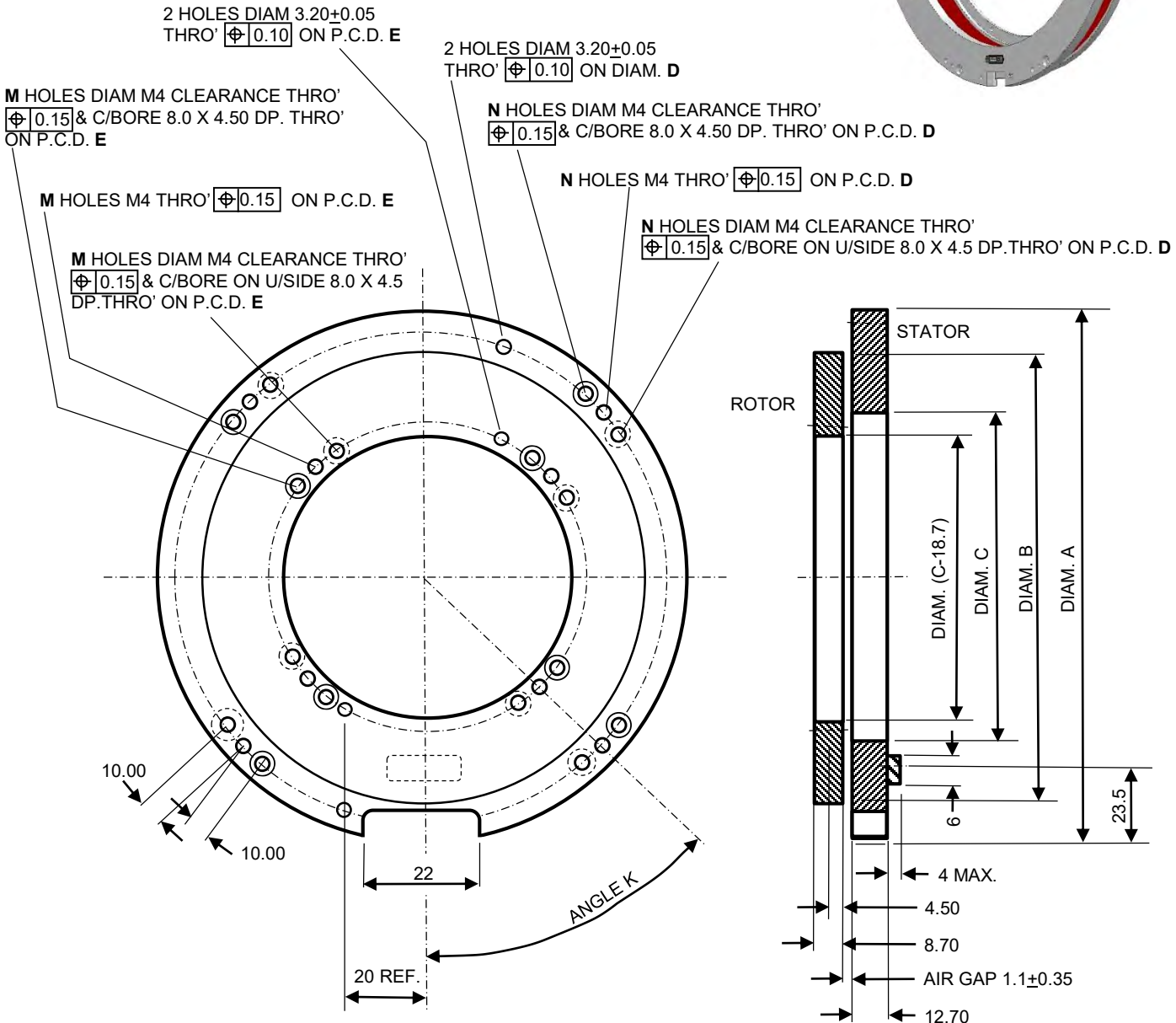

	INC-13-325	INC-13-379	INC-13-429	INC-13-595	
Diam. A : Stator O.D.	325.00	379.00	429.00	595.00	mm
Diam. B : Rotor O.D.	304.10	358.10	408.10	574.10	mm
Diam. C : Stator I.D.	256.70	310.70	360.70	526.50	mm
Diam. D : Stator P.C.D.	312.50	366.50	416.50	582.50	mm
Diam. E : Rotor P.C.D.	248.70	302.70	352.70	518.70	mm
Angle J : Rotor Offset Angle	22.5	18	18	15	degrees
Angle K : Stator Offset Angle	22.5	18	18	15	degrees
N : Holes in Stator	8	10	10	12	
M : Holes in Rotor	8	10	10	12	
Max. Radial Misalignment			0.25		mm

3.2 External Mount Stator & Screw Mount Rotor – Installation Guide

External Mount Format IncOders can be installed in various ways and the following sketches show a few examples. Provided the axial gap and concentricity tolerances are maintained, then the stated measurement performance will be met.

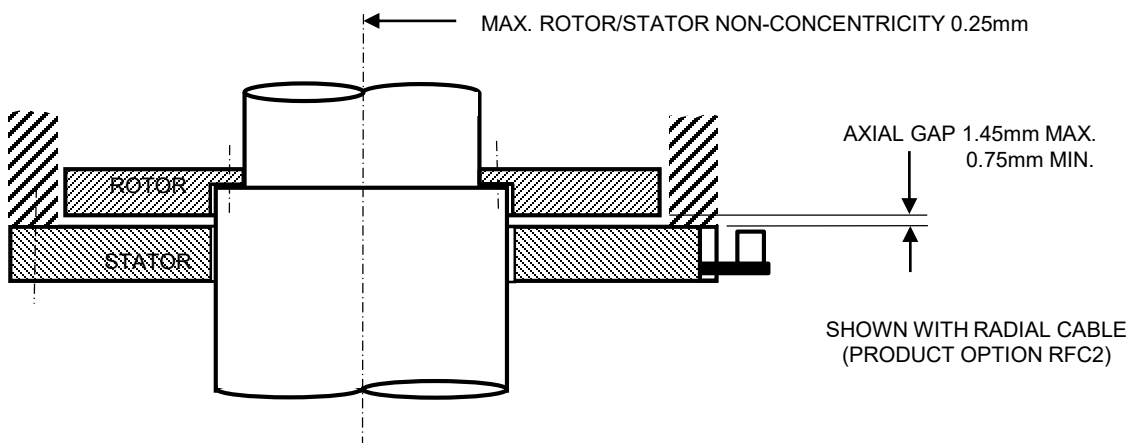
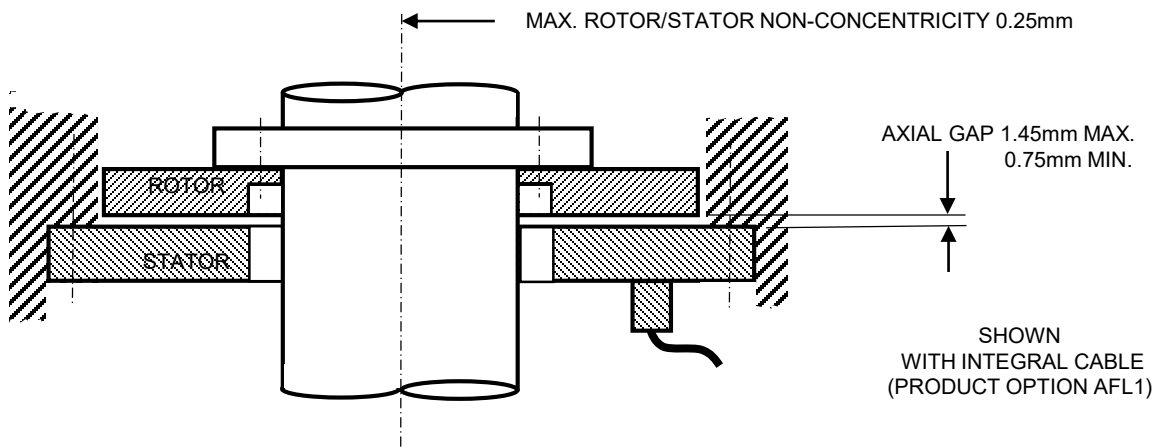
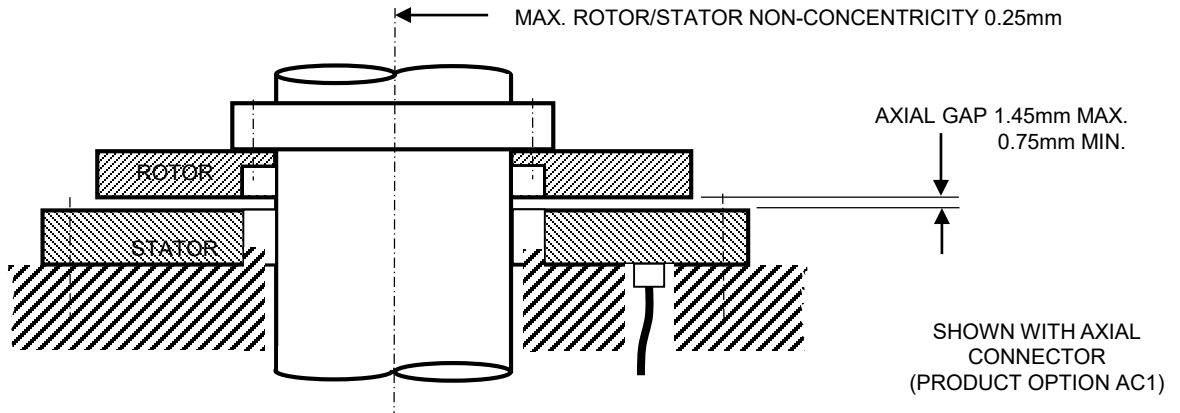

3.3 Radial Connections Product Options RFC1-14

There are 14 options for radial output connection. The images below show the options (*Midi sized IncOder shown*)



RFC1 – shown - vertical connector, 100mm long radial
RFC11 – as RFC1 but connector on obverse



RFC2 – shown - vertical connector, 12mm long radial
RFC12 – as RFC2 but connector on obverse



RFC3 – shown - 90 degree connector, 100mm long radial
RFC13 – as RFC3 but connector on obverse



RFC4 – shown - 90 degree connector, 12mm long radial
RFC14 – as RFC4 but connector on obverse

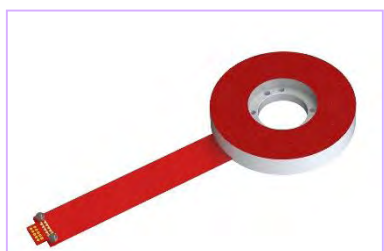

RFC5 – connector not fitted, plated through holes, 100mm long radial
For customer fit of connector



RFC6 – connector not fitted, plated through holes, 12mm long radial
For customer fit of connector

Radial connection types RFC7 to RFC10 include a 2m cable which is connected to the radial output with a boot, connector and heat-shrink construction. The 2m long cable is the same specification and colouring as the cable used for integral axial connection AFL type (see Table A Section 3.4.1) for all electrical outputs. The cable has stripped and tinned ends.

RFC7 – 2m downward cable & 12mm long radial

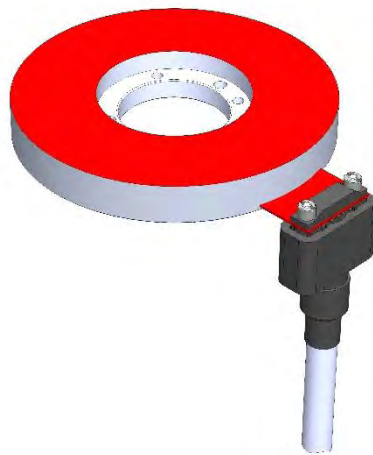

RFC8 – 2m upward cable & 12mm long radial

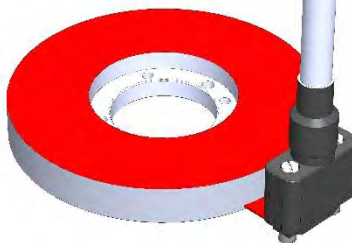

RFC9 – 2m downward cable & 100mm radial

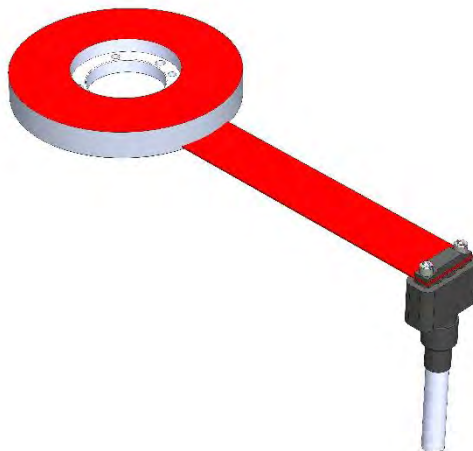

RFC10 – 2m upward cable & 100mm radial



3.3.1 Radial Connection Dimensions Product Options RFC1-4 & 11-14

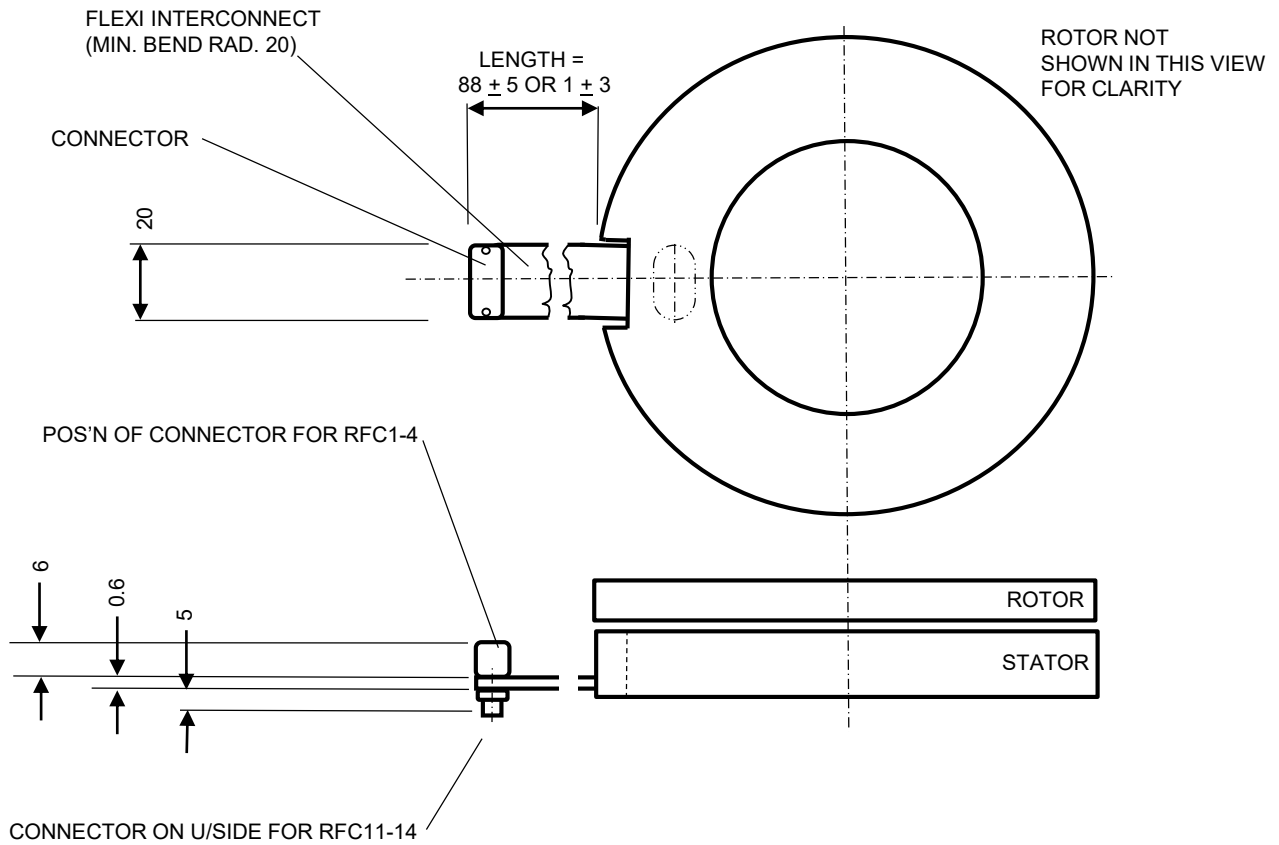

RFC1, 2, 11 & 12
VERTICAL CONNECTOR

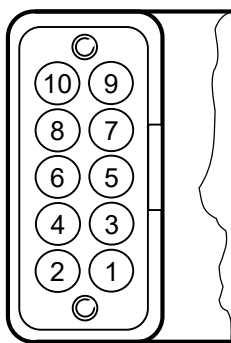

RFC3 & 4
90 DEGREE CONNECTOR

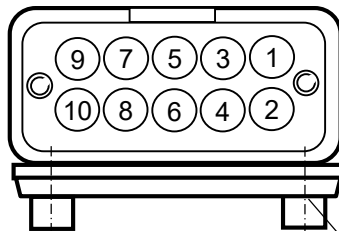

RFC13 & 14
90 DEGREE CONNECTOR

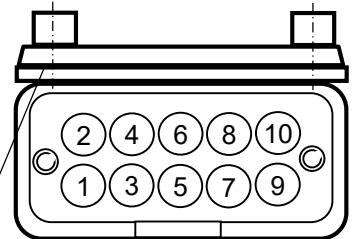

REMOVE THESE SCREWS ONLY IF ABSOLUTELY NECESSARY. IF REMOVED, ENSURE CONNECTIONS ON U/SIDE OF CONNECTOR ARE ALTERNATIVELY PROTECTED FROM CONTACTING CONDUCTIVE OR ABRADING SURFACES.

Notes

- See Section 5 for pin allocations of connectors shown above.
- Drawing above is in 3rd angle projection. Do not scale from drawing. All dims in mm.
- General tolerance = ± 1 mm unless stated
- In all instances, ensure that the weight (or inertia under shock or vibration) of the mating cable is taken by local strain relief and not the RFC connection.

3.3.2 Radial Connection Dimensions Product Options RFC5 & 6

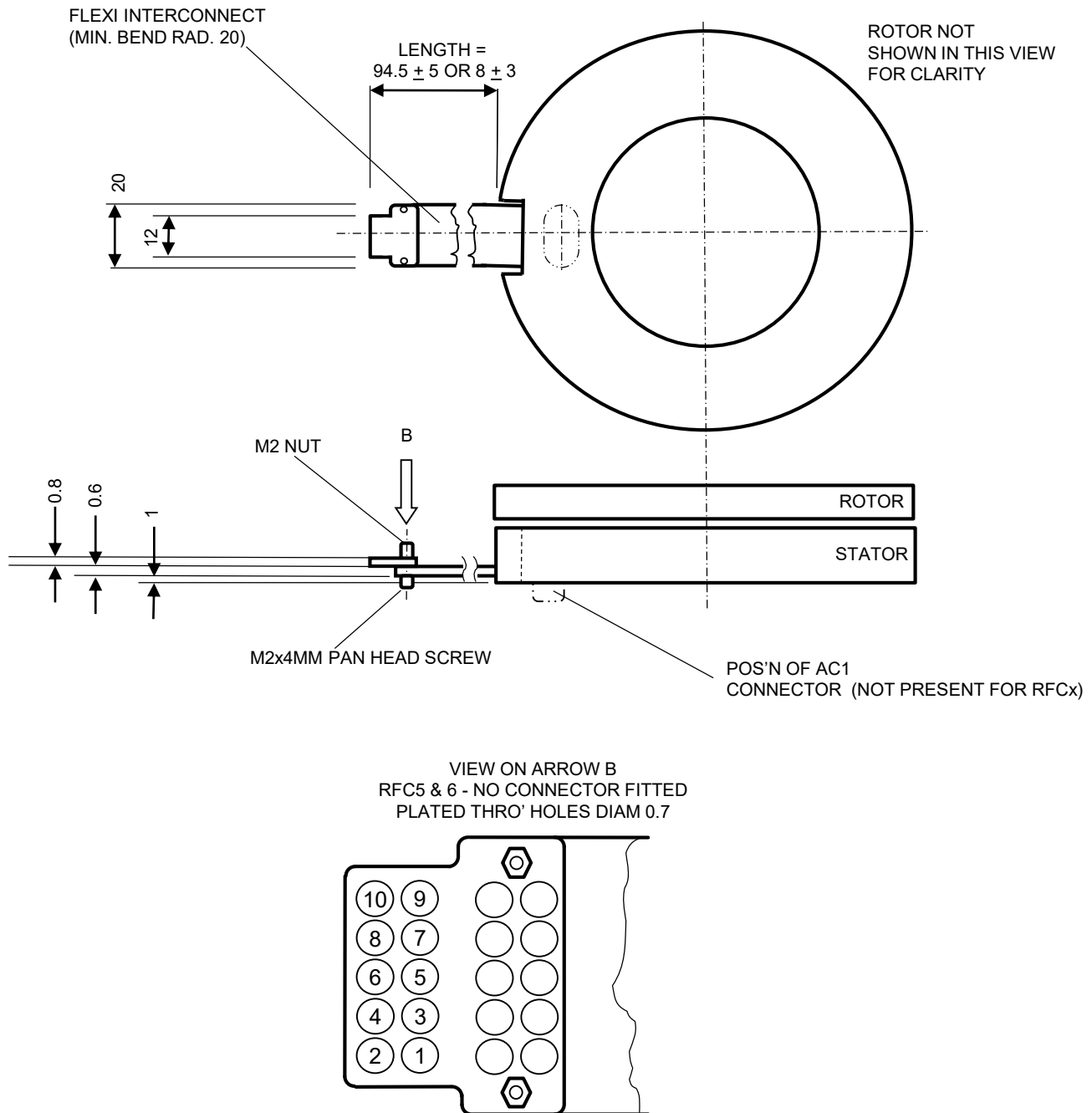

Notes

- Drawing above is in 3rd angle projection. Do not scale from drawing. All dims in mm.
- General tolerance = ± 1 mm unless stated
- In all instances, ensure that the weight (or inertia under shock or vibration) of the mating cable is taken by local strain relief and not the RFC connection.

3.3.3 Radial Connection Dimensions Product Options RFC7-10

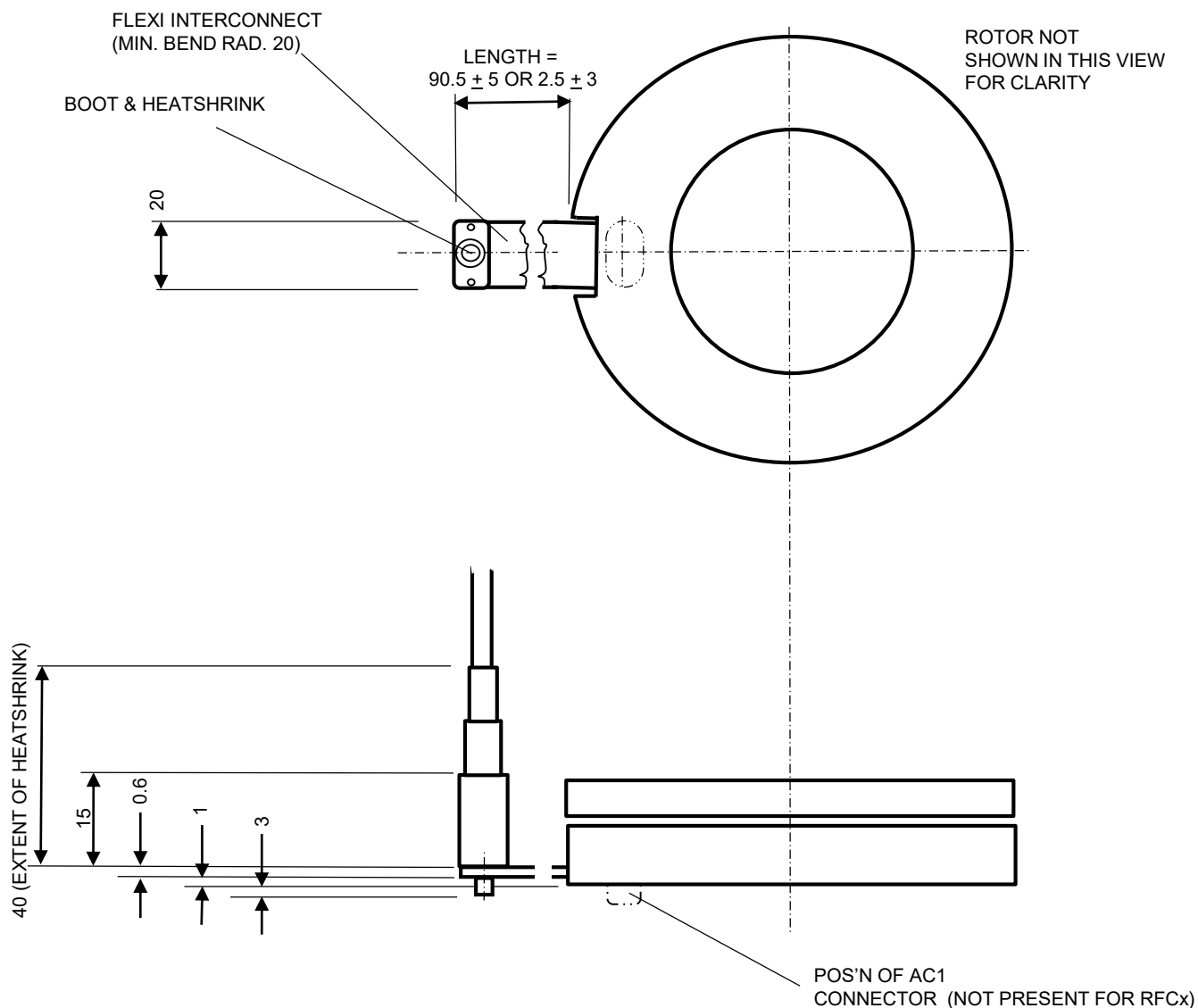

Notes

- See Table A in Section 3.4.1 for the wire and colour allocations
- Drawing above is in 3rd angle projection. Do not scale from drawing. All dims in mm.
- General tolerance = ± 1 mm unless stated
- In all instances, ensure that the weight (or inertia under shock or vibration) of the mating cable is taken by local strain relief and not the RFC connection.

Integral Axial Cables are for wet and/or severe shock/vibration environments. The connector is replaced by an integral cable and a block which covers the cable to IncOder joint.

- **AFL1 Integral Axial Cable.** IP67 for 1 hour & 1m depth. 2m long cable, 10-way, 24 AWG multi-strand copper wire, semi-rigid PVC insulation & outer jacket, twisted pairs, overall foil shield, tinned copper drain wire. Diam. 7.3mm. Min. flexing rad. = 76mm with a 1-off bend rad. (e.g. on installation) of 20mm. Operating temp.: -30 to 85°C.
- **AFL2 Integral Axial Cable, Sealed Rotor & Stator.** IP68 to 100m depth. Cable as per AFL1.
- **AFL3 Integral Axial, High Flex Cable.** IP67 for 1 hour & 1m depth and suitable for repeat bending (>5M cycles). IGUS CF11.02.05.02 cable, 2m long, TPE outer jacket, shielded, twisted pairs, 24AWG multi-strand, copper wire, PVC & halogen free. Hydrolysis, oil, UV & microbe resistant. Diam. 9.0mm. Min. radius 45mm (fixed) & 61mm (flexing). Operating temp.: -35 to +85°C (flexing) or -40 to +85°C (fixed). Operating temps. limited by IncOder, not cable.
- **AFL32 Integral Axial, High Flex Cable, Sealed Rotor & Stator.** IP68 to 100m depth. Cable as per AFL3.
- **AFL4 Integral Axial Cable, Low Profile.** IP67 for 1 hour & 1m depth. 0.6m long cable with individual Brand-Rex SPC00443A00x PTFE coated 24AWG multi-strand, copper wire, in twisted pairs, to BS 3G 210. No shielding or outer sheath. Specify this option if space is tight. Axial length of the plastic cover block is shorter than other AFL options and min. bend radius of wires is 20mm with a 1 off min. bend radius. (e.g. on installation) of 10mm. Cables must not be substantially axially loaded (0.5kg max.) or strained during handling, installation or use. This option is not recommended for high shock or vibration unless cable is strain relieved locally. Operating temp.: -60 to +85°C (limited by IncOder, not cable).
- **AFL42 Integral Axial Cable, Low Profile, Sealed Rotor & Stator.** IP68 to 100m. Cable as per AFL4.
- **AFL5 Integral Axial, PTFE/MIL-Spec Cable.** IP67 for 1 hour & 1m depth. 1.1m cable with individual Brand-Rex SPC00443A00x PTFE coated 24AWG multi-strand, copper wire, twisted pairs, to BS 3G 210, in overall Raychem RAY101-3.0 braided screen. Pro-Power STFE4-6.4-1.2MNAT PTFE outer sleeve. This non-flammable cable is resistant to oils, lubricants, fuels and is flexible. Min. flex rad.= 76mm with 1 off bend rad. (e.g. on installation) of 8mm. Operating temp.= -60 to +105°C (limited by IncOder, not cable).
- **AFL52 Integral Axial, PTFE/MIL-Spec Cable, Sealed Rotor & Stator.** IP68 to 100m. Cable as per AFL5.



AFL Dimensions :-

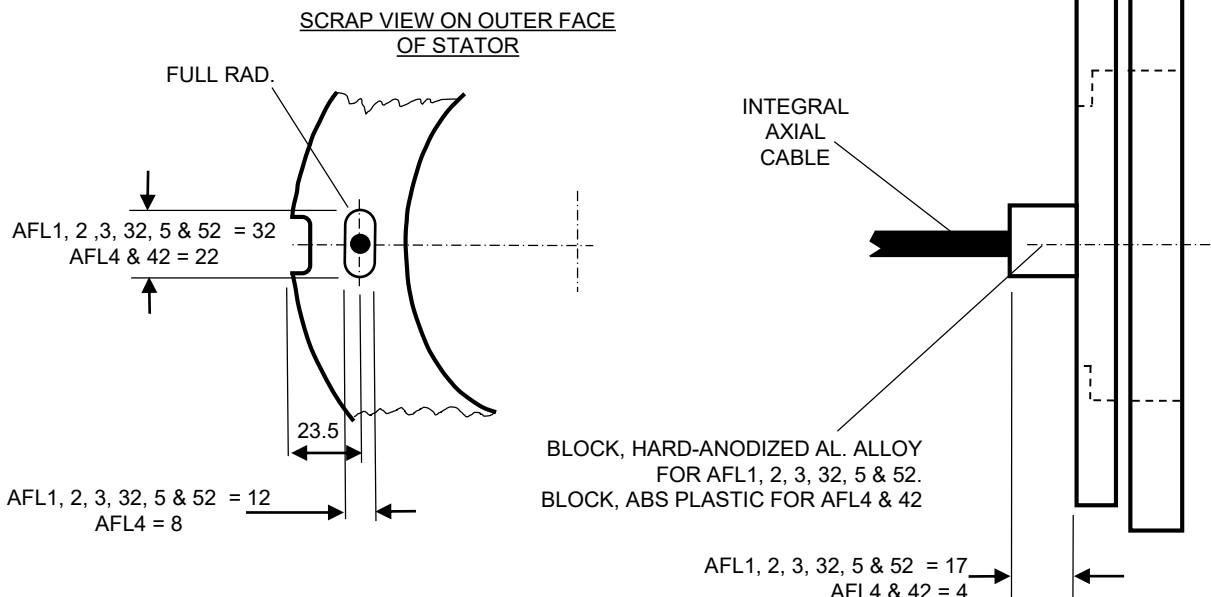

- Notes
- Drawing shown in 3rd angle projection. Do not scale from drawing
 - All dims in mm. Gen. tol. = ±1mm unless stated - all other dims as per relevant mechanical drawings.

Table A - Connections for AFL1, AFL2, AFL4, AFL42, AFL5, AFL52, & RFC6-10

Pair No.	Colour	Connector Pin (For Info. Only)	Signal (SSI1-9 & SPI & BISS-C)	Signal (AS11 & AS12)
1	Black	7	Data B	Data B
1	Green	5	Data A	Data A
2	Black	6	Clk B	Not used - do not connect
2	Blue	8	Clk A	Not used - do not connect
3	Black	9	0V	0V
3	Red	10	V _{supply}	V _{supply}
4	Black	1	Zero Set	Zero Set
4	Yellow	2	Zero Reset	Zero Reset
5	Black	3	Not used - do not connect	Not used - do not connect
5	White	4	Not used - do not connect	Not used - do not connect

Table B - Wiring connections for AFL3 & AFL32

Pair No.	Colour	Connector Pin (For Info. Only)	Signal (SSI1-9 & SPI & BISS-C)	Signal (AS11 & AS12)
1	Grey	7	Data B	Data B
1	Pink	5	Data A	Data A
2	Yellow	6	Clk B	Not used - do not connect
2	Green	8	Clk A	Not used - do not connect
3	Blue	9	0V	0V
3	Red	10	V _{supply}	V _{supply}
4	Violet	1	Zero Set	Zero Set
4	Black	2	Zero Reset	Zero Reset
5	Brown	3	Not used - do not connect	Not used - do not connect
5	White	4	Not used - do not connect	Not used - do not connect

Cable Lengths for AFL Product Options

Standard length for AFL1, AFL2, AFL3 & AFL32 cables is 2m. Standard cable length for AFL4 & AFL42 is 0.6m. Standard length for AFL5 & AFL52 is 1.1m. If a different cable length is required, simply change the part number from, for example, AFL1 to AFL1.5.0 for a 5.0m cable or from AFL32 to a AFL32.0.9 for a 0.9m cable. For shorter cables there is no price difference. There may be a price variation for integral cables longer than standard – contact Zettlex or your local rep. General tolerance on cable lengths is ± 50 mm.

Connectors for AFL Product Options

Fitting special connectors such as D-38999 military type or hermetically sealed connectors is something that Zettlex is frequently asked to do. Please contact Zettlex or your local representative if this is a requirement, stating cable type (see Section 3.4), cable length & connector type.



Extended Product Range Options are not necessary for most applications. In some, such as ultra high-spec applications in defence, aerospace and extreme duty industrial applications, Extended Product Options may be required. Extended Product Options increase product costs & lead-times and should only be specified if necessary.

Electronics with Leaded Solder – Extended Product Option ‘P’

Standard IncOders use RoHS compliant solder for electronic components. In some applications, the use of leaded solder is mandatory. Specify ‘P’ at the end of the standard Product Number.

Very High Shock & Vibration – Extended Product Option ‘G’

Standard IncOders are designed for high shock & vibration environments, often found in airborne, marine & military vehicles. In applications with prolonged, very high shock (to 500g for 11ms) and/or very high vibration environments (to 100g for 10-2000Hz) the Very High Shock & Vibration Product Option should be specified. Example applications include (direct mounted) weapons systems, wing mounted aerospace equipment and earth moving vehicles. This option is available in all IncOder sizes, formats and electrical interfaces but, preferably, should be used with integral cables (type AFL1, 2, 3 or 5). ‘G’ format IncOders have a reinforced internal structure. External mechanical & electrical interfaces are unchanged. Local strain relief of cables must be used in all applications with shock or vibration. Specify ‘G’ at the end of the standard Product Number.

Engraved Data – Extended Product Option ‘E’

Standard IncOder Stators carry a serial number on a self-adhesive, metalized label. In some applications, a label is not acceptable and product data must be engraved. Engraved data includes part number & serial number on exterior faces of housing. Specify ‘E’ at the end of the standard Product Number.

Alocrom Surface Finish – Extended Product Option ‘A’

Most standard IncOder aluminium-alloy housings have a clear, hard-anodized surface finish with low electrical conductivity. In some applications, housings must be electrically conductive to the host. Alocrom 1200 is an alternative, electrically-conductive surface finish, approved to DEF-STAN 03-18; MIL-C-5541C & MIL-C-81706. It has a golden colour and is often used in space applications. It contains hexavalent chromium and is not REACH compliant. Specify ‘A’ at the end of the standard Product Number.

SurTec 650 Surface Finish – Extended Product Option ‘S’

SurTec650 is standard finish on 37mm and 58mm IncOders. The aluminium alloy housings for Midi and Maxi IncOder have a clear, hard-anodized surface finish with low electrical conductivity. In some applications, housings must be electrically conductive to the host. SurTec650 Chromital[®] TCP is an alternative, electrically-conductive surface finish with a bluish-gold colour. It does not contain hexavalent chromium; is REACH compliant and has excellent corrosion protection. It meets or exceeds MIL-DTL-81706B & MIL-DTL-5541F (336h in NSS per ASTM B-117, respectively, DIN EN ISO 9227). It has a low electrical contact resistance (<5000µOhm per square inch as per MIL-DTL-81706B). Specify ‘S’ at the end of the standard Product Number.



Cold Temperature Option – Extended Product Option ‘12CT’ or ‘24CT’

Standard IncOders have a lower operating temperature limit of -45°C . For prolonged or frequent operation at temperatures $<-45^{\circ}\text{C}$, a cold temperature version (lower operating temperature of -60°C) should be specified using the 12CT or 24CT Extended Product Option in the voltage supply section of the part number. For operating temperatures $<-60^{\circ}\text{C}$ consult Zettlex.

High Temperature Option – Extended Product Option ‘5HT’

Standard IncOders have an upper operating temperature limit of $+85^{\circ}\text{C}$. For prolonged or frequent operation at temperatures $>85^{\circ}\text{C}$, a high temperature version (upper operating temperature of $+105^{\circ}\text{C}$) should be specified using the 5HT Extended Product Option in the voltage supply section of the part number. Careful selection of the appropriate cable is required for high operating temperatures. Generally, the high temperature cable INC-CAB3-2HT should be specified or the AFL5/ALF52 integral cable. For operating temperatures $>105^{\circ}\text{C}$ consult Zettlex.

Prolonged Immersion, Salt Spray or Extreme Dust Conditions – Extended Product Option ‘C’

Standard IncOders will operate reliably if subject to moist, wet, dusty or salt spray conditions for short or infrequent periods. Such conditions include immersion in mineral oil or water – depending on cable connection selected. If the IncOder will be subject to prolonged periods of high levels of condensing moisture, immersion in water, exposure to salt atmospheres or potential abrasion by dust or grit then Extended Product Option C is recommended. This option provides additional protection to the IncOder’s sensing faces using an acrylic conformal coat. This option is not required if immersion is in mineral oil. This option is not required (because it is already included) if a sealed version of integral axial cable is selected e.g. AFL2, AFL32, AFL42 or AFL52. Specify ‘C’ at the end of the standard Product Number.

High Pressure Option – Extended Product Option ‘V’

If operation at high pressures is needed (for example, sub-sea equipment submerged in mineral oil) then the use of Extended Range Product Option ‘V’ is recommended. Maximum recommended operating pressure is 4,000psi or 280Bar. Higher operating pressures may be possible subject to qualification by the user in host equipment. ‘V’ designated products undergo a hard epoxy encapsulation process which ensures absence of internal voids. Specify ‘V’ at the end of the standard Product Number.



Measurement, Electrical, Environmental & Other Data for IncOrder Maxi Range

	INC-13-325	INC-13-379	INC-13-429	INC-13-595	
Measurement	Absolute over 360°. Note this is true absolute - no motion required at start up				
Resolution (181001 Product Option)	18bits	262,144counts per rev	4.94arc-secs	24micro-rads	
Resolution (191001 Product Option)	19bits	524,288counts per rev	2.47arc-secs	12micro-rads	
Resolution (201001 Product Option)	20bits	1,048,576counts per rev	1.24arc-secs	6micro-rads	
Resolution (211001 Product Option)	21bits	2,097,152counts per rev	0.62arc-secs	3micro-rads	
Resolution (221001 Product Option)	22bits	4,194,304counts per rev	0.31arc-secs	1.5micro-rads	
Repeatability	+/-1				LSB
Static Accuracy over 360°	≤38	≤40	≤45	≤60	arc-seconds
Static Accuracy over 360°	≤0.19	≤0.20	≤0.22	≤0.29	milliradians
Internal Position Update Period	≤0.1				millisecond
Thermal Drift Coefficient	≤0.50				ppm/K Full-Scale
Max. Speed for Angle Measurement	4,500				r.p.m.
Max. Physical Speed	10,000				r.p.m.
Data Outputs	RS422 Compatible, supports SSI (Serial Synchronous Interface), asynchronous serial interface, SPI or BiSS-C				
Power Supply	5VDC (4.5-32VDC) or 12VDC (4.5-32VDC) or 24VDC (4.5-32VDC)				VDC
Current Consumption	<100 (typically <75 and does not change significantly with voltage supply)				milliAmp
Reverse Polarity	PSU Reverse polarity protected to max. supply voltage				VDC
Connector (AC1 & RFCx Product Option)	Harwin Data Mate Vertical Plug 10 Way with 2 Jack Screws Type M80-500-10-42 or M80-510-10-42 or M80-540-10-42 For alternative connectors such as military shell type contact Zettlex				
Mating Connector (AC1 & RFCx)	Harwin Data Mate Vertical Socket Type M80-461-10-42 (alternative M80-461-10-05)				
Zero Setting	Via Connector or integral cable (AFLx) - see details for set and reset in relevant Section				
Power Up Time To 1st Measurement	<100				millisecond

Environmental					
Operating Temperature	Minus 45 to +85 Minus 60 to +85Celsius for 12VCT & 24VCT Extended Range Product Options. Minus 45 to 105Celsius for 5HT Extended Range Product Options. Operation outside limits to be qualified by user. Options available below minus 60 Celsius operation: contact Zettlex or local representative				Celsius
Storage Temperature	Minus 55 to +125 (Minus60 to +125 for 24CT Product Option)				Celsius
Temperature Shock	MIL-STD-810G, Method 503.5, Procedure I-B (T1=-40°C, T2=55°C.)				
IP Rating - Rotor & Stator	IP67 for <60 minutes & 1m depth (Installed with mechanically protected connector or AFL1, 3, 4, 5 & VFL Product Options) IP68 100m depth (Installed with mechanically protected connector or AFL2 Product Option) For immersion at depths of >100m select Extended Range Option 'V'				
IP Rating - Connector	IP50 (AC1 or RFC11-14 Product Option). IP68 for RFC6-10. See Section 3.4 for IP rating of Integral Cable Product Option				
Humidity	RH 0-99% as standard. Select Extended Range Option C and appropriate integral cable for condensing humidity or long term immersion				
Salt Fog	(Installed with protected cable/connector or any integral axial cable) Complies with DEF STAN 00-35 Pt. 3 Iss. 4, Test CN2 Salt Mist Test. Select Extended Range Option C and appropriate connector for environments with prolonged or significant exposure to salt fog				
Bio Hazards	(Installed with protected cable/connector or any AFL connection) Complies with DEF-STAN 00-35 Pt. 4 Iss. 4 Section 11 (Hazards)				
Induced Dust & Sand	Standard units comply with DEF STAN 00-35 Pt 3 Iss 4, Test CL25 (Turbulent Dust) Cat 1. Select Extended Range Option C and appropriate connector for environments with extreme levels or particularly abrasive dust or sand.				
Mechanical Impact Resistance	IK07 - when installed - suitable for mechanical impacts from objects of >200grams from 1m height				
Shock	IEC 60068-2-6 100g for 11ms - axial & radial - suitable for most airborne, marine & armoured vehicles MIL-STD-810G, Method 516.6, Procedure I-Functional Shock - axial and radial - 40 g 11 ms, sawtooth waveform For more extreme or prolonged conditions specify Extended Product Option G and preferably Integral Axial Cable Product Options				
Vibration	IEC 60068-2-6 20g for 10-2000Hz - axial and radial - suitable for most high vibration & airborne environments MIL-STD-810G, Method 514.6, Procedure I - axial and radial - Category 20, for tracked vehicles For more extreme or prolonged conditions specify Extended Product Option G and preferably Integral Axial Cable Product Options				
Environmental pressure range	0 to 7 (in other words vacuum to 7). See Extended Product Range High Pressure Option for higher operating pressures				Bar
Max. permissible press. change rate	1				Bar/second
EMC Radiation Susceptibility	(Installed) Complies with IEC 61000-6-2 - suitable for fitment in harsh EMC environments				
EMC Radiated Emissions	(Installed) Complies with IEC 61000-6-4 - suitable for fitment adjacent to EMI sensitive devices				

Materials	
Rotor & Stator Housings	Standard range:- Housings in aluminium alloy (6061-T6 or 6084-T6) with clear, hard-anodised surface finish. Alternate (conductive) surface finishes in Extended Product Option A: Alcrom or S: SurTec650. Sensor surfaces: FR4 grade epoxy.
Connector (AC1 or RFCx Product Option)	PPS with Stainless Steel Screw Fixings and Gold & Tin Electrical Connections

Miscellaneous	
MTBF	0.22 failures per 1M hours based on MIL-HBK-217+ method for ground military vehicles at 20Celsius average
MTBF	0.35 failures per 1M hours based on MIL-HBK-217+ method for naval sheltered at 35Celsius average
Hazardous materials	Standard range - Hazardous materials not used. RoHS compliant. RoHS certificate available. REACH statement available.
Outgassing materials	Complies with NASA classification as low outgas mat. with TML <1% & CVCM <0.1% at 125C & 24hrs in vac to ASTM E-595-90
ITAR classification	Not ITAR controlled. No ITAR components
Approvals	Flammability Rating UL94V-0. Standard range - RoHS compliant - RoHS certificate available. REACH statement available.
Marking	Zettlex, logo, CE & UL94V-0 printed on Rotor & Stator faces: Serial No. labelled on exterior diameter of Stator housing
Country of Manufacture	UK
Export Licence Requirements	Not required for products of <1000mm diameter

The Maxi IncOder range offers 4 different Communication Interfaces:-

- Synchronous Serial Interface – see Section 4.4 (Product Options SS11-9)
- Asynchronous Serial Interface – see Section 4.5 (Product Option ASI1-2)
- Serial Peripheral Interface – see Section 4.6 (Product Option SPI1)
- BiSS-C – see Section 4.7 (Product Options BIS1)

All digital Communications Interfaces conform to the RS422 Standard. Note that for all Communications Interfaces, DATA & CLOCK inputs are not terminated with load resistors.

4.1 Output Resolution

The IncOder range offers various Options for the resolution of the output data. The required digital resolution is simply specified using the relevant Product Option – see Section 8.

INC - X - XXX - XXXXXX - XXXX - XXXX - X - XXX

Resolution measured in bits.	
10 Bits 101001	18 Bits 181001
11 Bits 111001	19 Bits 191001
12 Bits 121001	20 Bits 201001
13 Bits 131001	21 Bits 211001
14 Bits 141001	22 Bits 221001
15 Bits 151001	
16 Bits 161001	
17 Bits 171001	

4.2 Multi-Turn or Single Turn

The default electrical output from an IncOder is over 1 rev. For multi-turn devices please contact Zettlex or your local rep. IncOder offers the possibility to count how many turns have been made by modifying the IncOder's software. To maintain turn count, an uninterruptable power supply is necessary.

4.3 Zero Point Set & Zero Reset

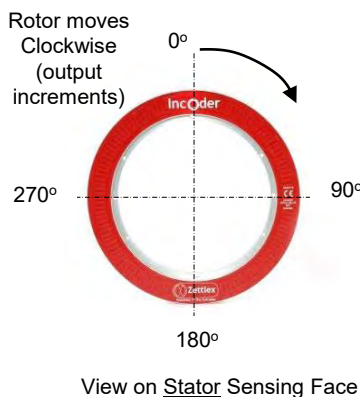

The Zero Point is the datum from which angle is measured. As supplied, the IncOder carries a factory Zero Point setting. For Screw Mount & Duplex products the Zero Point is in a range of +/-5° of the Rotor and Stator dowel positions at 12 o'clock (near the 'O' of the printed 'IncOder'). The Zero Point can be changed using the Zero Set and Zero Reset lines on the IncOder's electrical interface. The Zero Set signal will set the current IncOder position as the Zero Point (held in memory when power removed). Zero Reset signal will reset the Zero Point to the factory setting (held in memory when power removed). To use, the relevant connection should be connected to electrical ground (<0.5V) for ≥1 second at power up but left unconnected (i.e. open circuit) during operation.

4.4 Synchronous Serial Interface (SSI) – Product Options SSI1-SSI9

4.4.1 Generic Protocol Definition– Product Options SSI1-SSI9

SSI is a widely used serial interface between position sensors and controllers. It is based on the RS-422 hardware standard and implements a differential output for the DATA and a differential input for the CLOCK. (Note that DATA outputs and CLOCK inputs are not terminated with load resistors.)

Synchronous SSI uses a clock sequence from a controller to initiate the transmission of position data from the sensor (a Read Cycle), with the latest position data (see Section 5 for internal position update rate) available for transmission after each SSI Read Cycle is completed. See timing information below:-

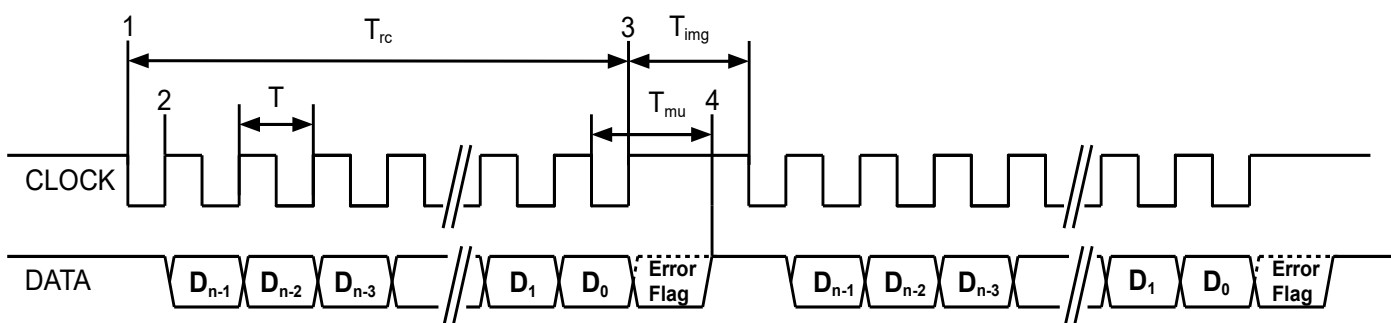

T: Clock Period ($1/T = 100 \text{ kHz to } 2 \text{ MHz}$)

Trc: Read Cycle time: This is defined as $(n \times T) + (0.5 \times T)$

Tmu: Message Update time. The time from last falling edge of clock to when new data is ready for transmission.

$T_{mu} = 20\mu\text{s} \pm 1 \mu\text{s}$. The DATA line will be HIGH after this time indicating a new Read Cycle can be started.

Timg: Intermessage Gap time. Must be $> T_{mu}$ otherwise position data will be indeterminate.

n: The number of bits in the message (not including the Error Flag).

In idle state CLOCK and DATA are both HIGH

Notes:

1. The first falling edge after T_{mu} starts the Read Cycle and the transfer of data.
2. Each rising edge of the CLOCK transmits the next data bit of the message, starting with D_{n-1} .
3. After the last rising edge of the clock sequence, the data line is set by the Error Flag (if supported) for the period $T_{mu} - 0.5 \times T$
4. After T_{mu} , the latest position data is now available for transmission in the next Read Cycle – see Section 5 for position update rate.

SSI can support a variety of protocols in which data is transmitted depending on the requirements of the SSI controller. **IncOder can be supplied with any of the following protocols – just choose what you need by using the relevant Product Option when ordering (see Section 6).** If the protocol you require is not listed here then please consult Zettlex or your local representative.

Most popular choice

SSI1 (n = 24)

D23	PV	Position Valid Flag. Set to 1 when data is valid, otherwise 0 (the inverse of the ERROR FLAG).
D22	ZPD	Zero Point Default. Set to 1 when the Zero Point is at Factory Default, otherwise 0
D21-D0	PD[21:0]	Binary position data. If resolution of device is less than 22 bits, then the MSBs of this field are set to 0. The LSB of this field is in D0. When PV is 0, PD[21:0] value is not defined.

SSI2 (n = 24)

D23-D2	PD[21:0]	Binary position data. If resolution of device is less than 22 bits, then the MSBs of this field are set to 0. The LSB of this field is in D2. When Alarm bit is 1, PD[21:0] value is not defined.
D1	P	Parity Bit 0 indicates an even number of 1's in data (D23-D2), 1 indicates an odd number of 1's in data.
D0	A	Alarm Bit – 0 indicates normal operation, 1 indicates error condition.

SSI3 (n = 16)

D15-D0	PD[15:0]	Binary position data. When ERROR FLAG is 1, PD[15:0] value is not defined.
---------------	----------	----------------------------------------------------------------------------

Note: the use of SSI3 effectively limits the measurement resolution to a maximum of 16bits. If a higher resolution is specified in the part number, the least significant bits will not be accessible by the user.

SSI4 (n = 32)

D31	PV	Position Valid Flag. Set to 1 when position data valid, otherwise 0 (inverse of ERROR FLAG).
D30	ZPD	Zero Point Default. Set to 1 when the Zero Point is at Factory Default, otherwise 0
D29-D11	PD[18:0]	Binary position data. If resolution of device is less than 19 bits, then the MSBs of this field are set to 0. The LSB of this field is in D11. When PV is 0, PD[18:0] value is not defined.
D10-D0	TS[10:0]	Time stamp data. The value of the Time Stamp counter when the position was measured. This data is always valid. The Time Stamp counter is a continuously incrementing counter in the range: 0.00ms to 20.47ms (at which point it restarts at 0.00ms). It has a resolution of 10us, with an accuracy better than 1% (based on the system oscillator).

Note: the use of SSI4 effectively limits the measurement resolution to a maximum of 19bits. If a higher resolution is specified in the part number, the least significant bits will not be accessible by the user.

SSI5 (n = 16)

D15-D0	PD[15:0]	Gray code, position data. When ERROR FLAG is 1, PD[15:0] value is not defined.
---------------	----------	--------------------------------------------------------------------------------

Note: the use of SSI5 effectively limits the measurement resolution to a maximum of 16bits. If a higher resolution is specified in the part number, the least significant bits will not be accessible by the user.

SSI6 (n = 32)

D31-D24	CRC[7:0]	CRC-8: To verify transmission, calculate the CRC of the bottom 24 bits of the message. The resulting CRC should be the same as the received CRC field. The following parameters define CRC-8: Polynomial 0x97 Initial data 0x00 MSB First (not reversed) No final XOR calculation
D23	PV	Position Valid Flag. Set to 1 when position data is valid, otherwise 0 (the inverse of the ERROR FLAG).
D22	ZPD	Zero Point Default. Set to 1 when the Zero Point is at Factory Default, otherwise 0
D21-D0	PD[21:0]	Binary position data. If resolution of device is less than 22 bits, then the MSBs of this field are set to 0. The LSB of this field is in D0. When PV is 0, PD[21:0] value is not defined.

SSI7 (n = 30)

D29-D24	-	Data always 0.
D23-D2	PD[21:0]	Binary position data. If resolution of device is less than 22 bits, then the MSBs of this field are set to 0. The LSB of this field is in D2. When Alarm bit is 1, PD[21:0] value is not defined.
D1	P	Parity Bit 0 indicates an even number of 1's in data (D23-D2) 1 indicates an odd number of 1's in data.
D0	A	Alarm Bit – 0 indicates normal operation, 1 indicates error condition.

SSI8 (n = 18)

D17-D0	PD[17:0]	Gray code, position data. When ERROR FLAG is 1, PD[17:0] value is not defined.
---------------	----------	--------------------------------------------------------------------------------

Note: the use of SSI8 effectively limits the measurement resolution to a maximum of 18bits. If a higher resolution is specified in the part number, LSBs will not be accessible by the user.

SSI9 (n = 32)

D31	PV	Position Valid Flag. Set to 1 when position data valid, otherwise 0 (inverse of ERROR FLAG).
D30	ZPD	Zero Point Default. Set to 1 when the Zero Point is at Factory Default, otherwise 0
D29-D11	PD[18:0]	Binary position data. If resolution of device is <19bits, then the MSBs of this field are set to 0. The LSB of this field is in D11. When PV is 0, PD[18:0] value is not defined.
D10-D0	TS[10:0]	Time stamp data. The value of the Time Stamp counter when the position was measured. This data is always valid. The Time Stamp counter is a continuously incrementing counter in the range: 0.00ms to 2.047ms (at which point it restarts at 0.00ms). It has a resolution of 1us, with an accuracy better than 1% (based on the system oscillator).

Note: the use of SSI9 effectively limits the measurement resolution to a maximum of 19bits. If a higher resolution is specified in the part number, the LSBs will not be accessible by the user.

4.5 Asynchronous Serial Interface Protocol – Product Options ASI1 & ASI2

This section describes the communications interface for IncOders with ASI1 or ASI2 serial protocols. Data is transmitted by the IncOder continuously formatted into Frames. Each Frame consists of a number of 8 bit data words. Each 8 Bit data word (or byte) is transmitted from a standard UART using N-8-1 (no parity, 8 data bits, 1 stop bit). ASI1 has a Baud rate of 230400 and ASI2 has a Baud rate of 921600. See below for the data format of each transmitted data word. The Frames are transmitted at a rate of 10kHz nominal (same rate as Internal Position Update Period).

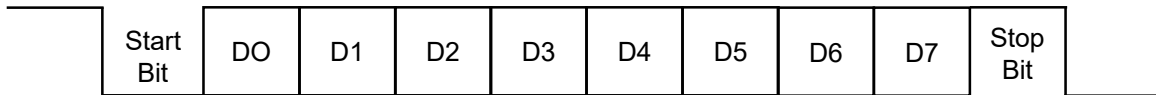

The following is the Asynchronous Serial Data protocol specified with the ASI1 or ASI2 Product Option. Each frame is defined as 6 bytes and the data format is defined as follows:

First byte (transmitted first):

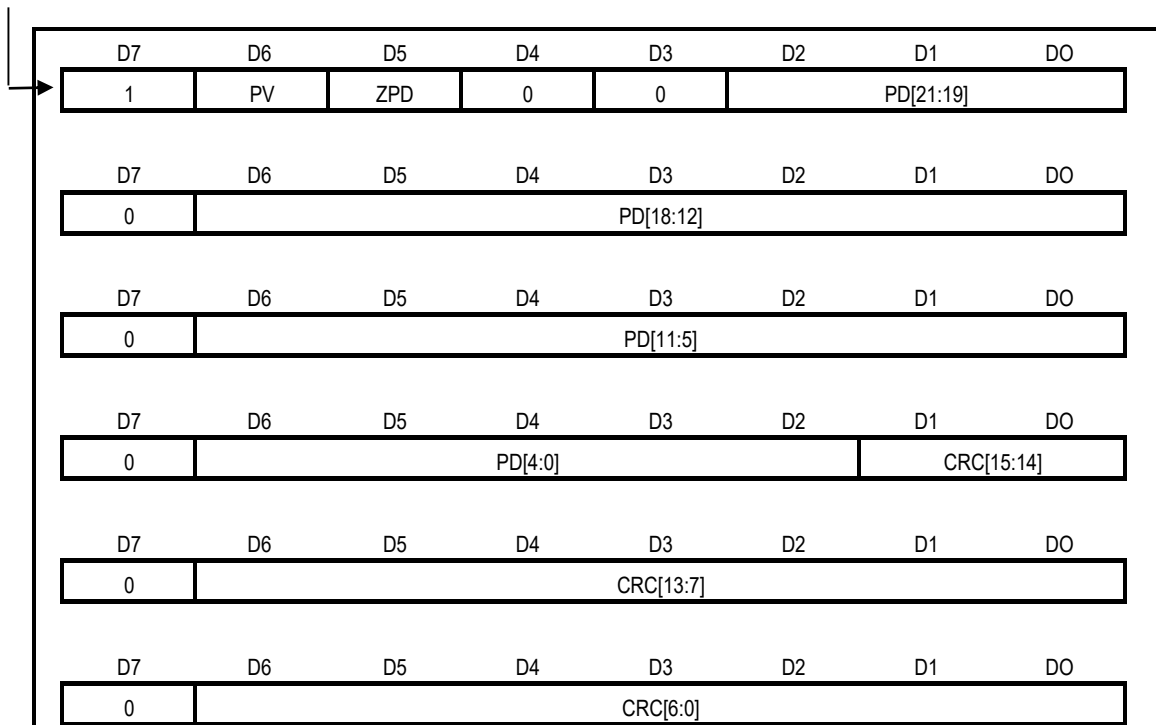

Data Definition for Asynchronous Serial Interface

- PV Position Valid flag. Set to 1 when data is valid, otherwise set to 0
- ZPD Zero Point Default. Set to 1 when the Zero Point is at Factory Default, otherwise set to 0.
- PD[21:0] IncOder Position Data. If resolution of device is less than 22 bits then the MSBs of this field are set to 0.
When PV is 0, PD[21:0] value is not defined.
- CRC[15:0] CRC-16: To verify transmission, calculate the CRC of all 48 bits of the message but with CRC[15:0] set to 0.
The resulting 16 bit CRC result should be the same as the received CRC[15:0].
Use the following CRC-16 parameters:
 - Polynomial 0x8005
 - Initial data 0x0000
 - MSB first (not reversed)
 - No final XOR calculation.

This section describes the communications interface for IncOders with SPI1 (Serial Peripheral Interface) serial protocol. SPI is a widely used serial interface between micro processors/controllers and peripherals. SPI uses a clock sequence from a master to control the transmission of data from the IncOder. IncOders with SPI data interface conform to the RS422 hardware specification.

Note that the DATA outputs and the CLOCK inputs are not terminated with load resistors.

The following section defines the communication protocol.

The IncOder protocol specifies that each data frame consists of 6 bytes of data (each of 8 bits, 48 bits in total) containing the position, status flags and CRC (see timing diagram on the following page).

SPI Clock Polarity is defined so that the CLOCK idle state is HIGH and the Clock Phase is defined so that the data is captured on the falling edge of CLOCK, and the data is propagated on the rising edge of CLOCK. This is commonly depicted as CPOL=1, CPHA=0 (also depicted as UCCKPL=1, UCCKPH=1).

Clock rate is 100kHz to 5MHz.

Data Definition for IncOder SPI Protocol

D47-D33	SBZ	These bits will always be Zero.
D32	ZPD	Zero Point Default flag. Set to 1 when the Zero Point is at Factory Default, otherwise 0.
D31	PV	Position Valid Flag. Set to 1 when position data is valid, otherwise 0.
D30	PS	Position Synchronised flag. Set to 1 when the position measurement was triggered by a previous SPI Frame. Set to 0 when the position measurement was triggered by a Measurement Time-out (see note 3 overleaf). Use this flag to ensure that the IncOder has synchronised position measurements to the SPI Frames (Case 1, overleaf).
D29-D8	PD[21:0]	Binary position data. If resolution of device is less than 22 bits, then the most significant bits of this field are set to 0. The LSB of this field is in D0. When PV is 0, PD[21:0] value is not defined.
D7	SD	Stale Data flag. Set to 1 when the position data has been transmitted at least once before. Set to 0 when the position data has not been transmitted before. Use this flag to detect when a new measurement has been completed (Case 2, overleaf).
D6-D0	CRC[6:0]	Cyclic Redundancy Checksum. 7 Bit CRC: Polynomial 0x5B, Initial data 0x0000, MSB first (not reversed), No Final XOR.

Note – the CRC is generated from bits D7 through D32. It is calculated using a 32 bit word (or 4 bytes) with D7 shifted in to the Least Significant Bit and the 6 Most Significant Bits set to '0' as required.

SPI Timing information

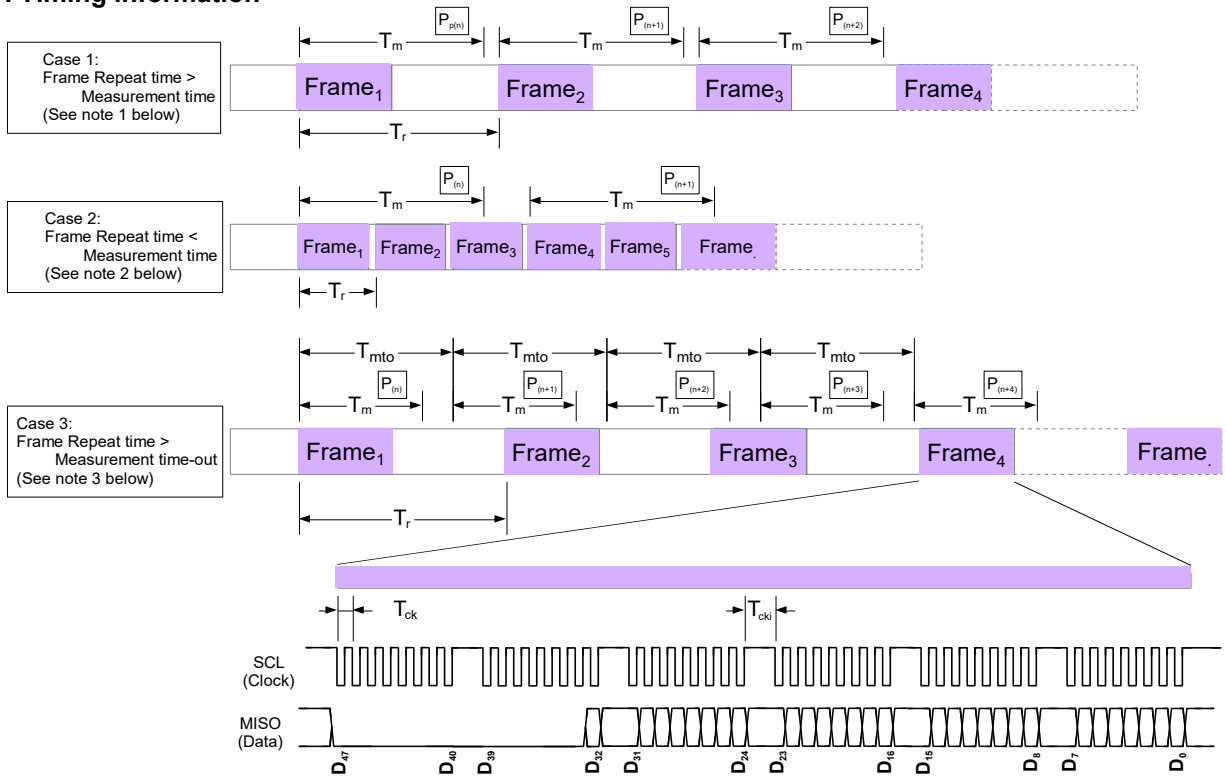

Timings determined by the Controller (SPI Master):

- T_{ck} Clock period (1/T = 100kHz to 5MHz).
- T_{cki} Clock Idle Period. Time between bytes during which CLOCK is idle. T_{cki} should be $< T_{cki\max} = 10\mu s$
- T_r Frame Repetition period.

Timings defined by the IncOder (SPI Slave):

- T_m Position Measurement time. The time from the start of a position measurement to when the position and status is ready for transmission. $90\mu s \leq T_m \leq 95\mu s$
- T_{mto} Position Measurement Time-out. The time after a position measurement has been triggered that the IncOder will automatically trigger a new measurement. $135\mu s \leq T_{mto} \leq 145\mu s$.

Notes:

- The IncOder will always attempt to trigger a new position measurement when a new SPI frame is started by the host. This will always be the case when T_r is greater than T_m and less than T_{mto} .
- If a position measurement has already been triggered when a new SPI frame is started by the host, then a new position measurement will not be re-triggered. This may be the case when T_r is less than T_m .
- If the Host does not start a new SPI frame within time T_{mto} from the previous frame (the case when T_r is greater than T_{mto}), then the IncOder will automatically trigger a new position measurement.
- In all cases, the IncOder will transmit the most recently completed measured position and status (see table below).
- When CLOCK is idle for at least $T_{cki\max}$, then the IncOder SPI interface will reset. The first falling edge on CLOCK after $T_{cki\max}$ will start the transmission of a new frame. This can be useful if the SPI host and slave (IncOder) lose Frame/Byte synchronisation (detected by invalid CRC).

Frame Number	Position transmitted (case 1)	Position transmitted (case 2)	Position transmitted (case 3)
Frame 1	$P_{(n-1)}$	$P_{(n-1)}$	$P_{(n-1)}$
Frame 2	$P_{(n)}$	$P_{(n-1)}$	$P_{(n)}$
Frame 3	$P_{(n+1)}$	$P_{(n-1)}$	$P_{(n+1)}$
Frame 4		$P_{(n)}$	$P_{(n+3)}$
Frame 5		$P_{(n)}$	

BiSS-C is a popular communications interface between controllers and position sensors. The IncOder BiSS-C interface is unidirectional and provides fast, compact, economic serial communications using RS422 (SSI) compatible hardware. The IncOder BiSS-C interface is a point to point configuration (a single device with a single slave), conforming to the requirements of BiSS-C Unidirectional. In this configuration, the IncOder is the only slave connected to the master (the host control system).

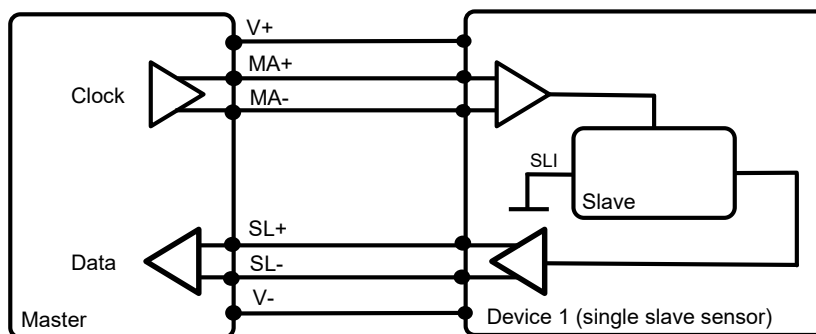

The Master transmits clock signals to the Slave via the MA line. The SL line carries the sensor data directly from the Slave back to the Master. The interface has only two unidirectional, differential lines (as the IncOder permanently connects the input SLI to '0'). Parameters for the individual data channels are specified below. These parameters can be pre-programmed in the controller and referenced via an ID or lookup table, or manually entered.

BiSS-C Timing Parameters

Symbol	Parameter	Min.	Max.	Unit
$1/T_{MA}$	Clock Frequency	600	2000	kHz
$T_{BISS-TIMEOUT}$	BiSS Timeout	15	20	micro-seconds

BiSS-C Data Channel Parameters

Number of Bits (SCD length)	31
Processing Time	12 Clock Cycles (12 x T_{MA} micro-seconds)
Data Area Length & Alignment	25Bits, Right Aligned
CRC	Width: 6Bits Polynomial: 0x43 Initial Value: 0x00 Output Inverted

Data Area Definition

MSB											LSB
F2	F1	FO	D21	D20	D19	D18	D3	D2	D1	DO

- F2: '1' = valid (the position reading is valid)
- F1: '1' = zero position default (the zero position is set to the factory default value)
- FO: '1' = sync (position data reading was synchronised to previous BiSS frame)
- D21: Most significant bit of the position data (if IncOder resolution is <22Bits the MSBs are set to '0')
- DO: Least significant bit of the position data.

Note. The IncOder implements a "pipelined" data output. The position (and status) returned in the Data Area Definition is from the reading triggered by the previous BiSS frame provided that the frame repetition period conforms to the requirements described for the SPI1 protocol (see Section 4.6).

5. Connector Diagram

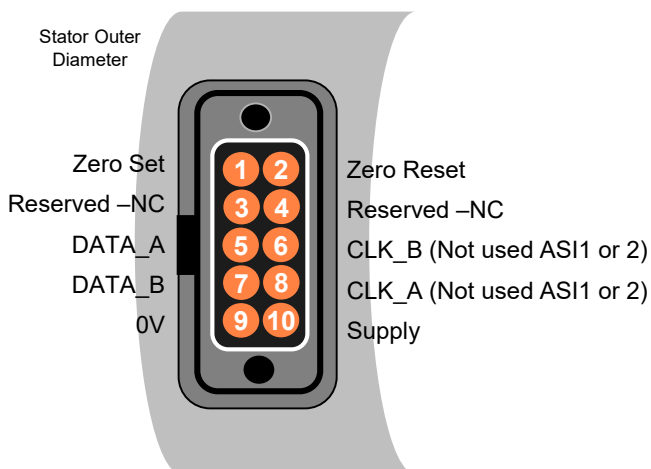

Notes:-

1. Data also applies to connectors at end of radial (RFCx) connections
2. 27kOhm pull up resistors fitted to Zero Set, Span Set, Direction Set, Zero Reset & Reset inputs
3. Reserved pins are for factory use only and should be left open circuit

6. Product Ordering (Maxi Range)

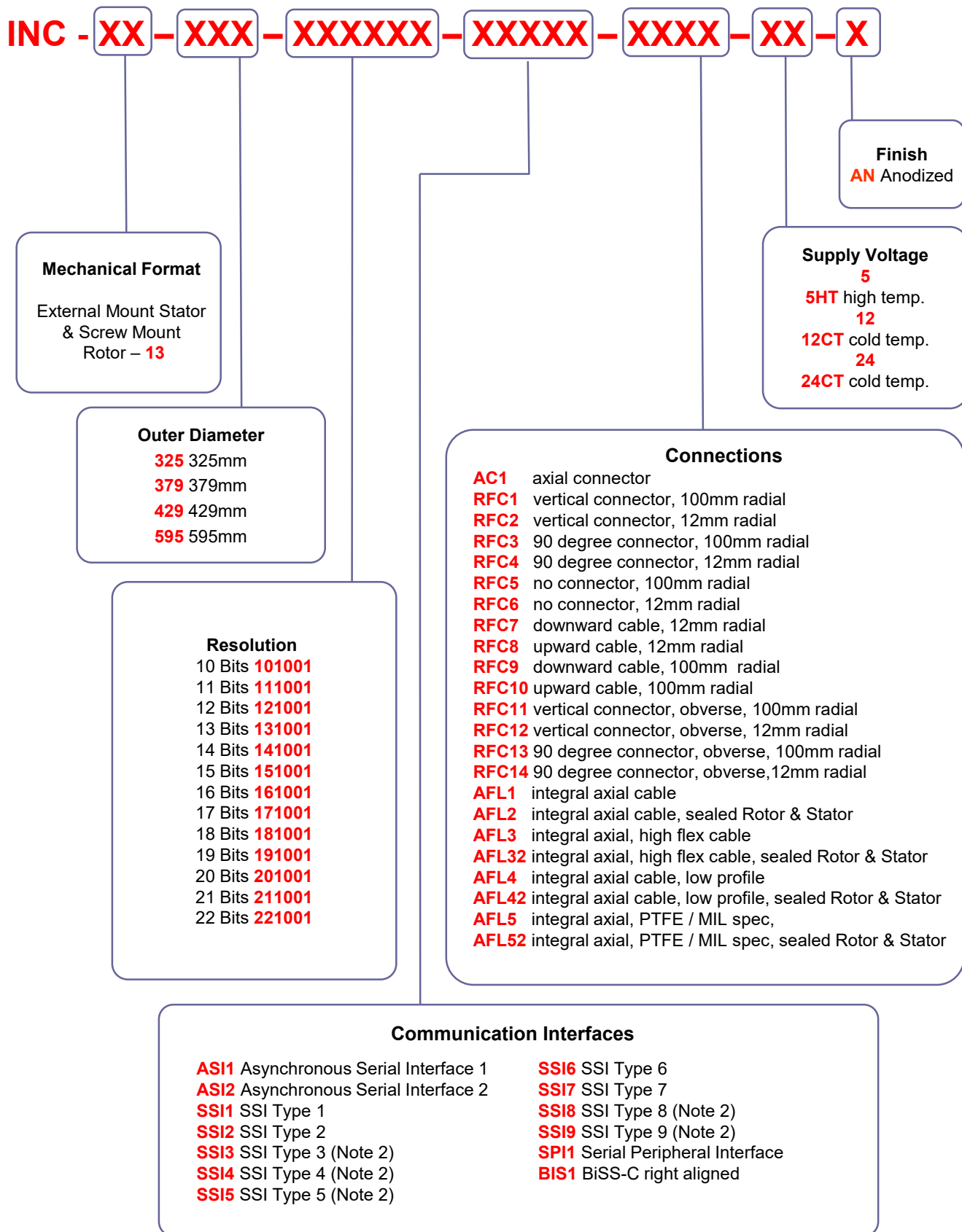

Notes:

- Each Maxi IncOrder includes 1 Stator & 1 Rotor
- Maximum effective resolution limited by communications protocol – see Section 4.4

If you have difficulty in specifying what you need, please contact Zettlex or your local representative.

Here are some example part numbers:-

INC - 13 – 325 – 181001 - SSI1 - AC1 – 12 - AN

External mount stator & screw mount rotor format, 325mm diameter, 18 bit resolution, SSI1, axial connector, 12V, hard-anodized.

INC – 13 – 595 – 121001 – SSI3 - AC1 – 5 – AN

External mount stator & screw mount rotor format, 595mm diameter, 12 bit resolution, SSI3, axial connector, 5V supply, anodized surface finish.

In the event that a custom or non-standard product is required, we will generate a part number accordingly – like the following example:-

INC – ACME – 508 – 141002 – X3601 - AB – 12CT - ABP

ACME design format, 508mm diam., 14 bit resolution, data output over 2 revs, 0.5 to 5.0V over 360° clockwise, custom connector, 12V supply, cold temperature option, Alocrom finish, Burn-in, leaded solder.

6.2 Product Ordering – Extended Range

For most applications Extended Product Range Options are not necessary. However, in those instances where these additional / alternative steps are mandatory or deemed necessary, please add the following Product Options to the end of the standard part number. One or more of Extended Product Range Codes may be added. Note that selection of any Extended Product Range Codes increase costs and lead-times and should only be specified if necessary.

- A** Alocrom 1200 conductive surface finish
- E** Engraved serial number and part number on Stator & Rotor (rather than serial label)
- G** Very high shock & vibration mechanical arrangement
- P** Use of leaded solder (rather than RoHS compliant solder)
- S** SurTec650 conductive surface finish (rather than clear, hard-anodized surface finish)
- V** Option for high operating pressure
- C** Conformally coated sensor faces.

For cold temperature option (to -60°C operating) select **12CT** or **24CT** in Supply Voltage Product Option.

For high temperature option (to 105°C operating) select **5HT** in Supply Voltage Product Option.

Example of an extended part number:

INC – 4 – 150 – 191001 - ASI1 - RFC1 – 12CT – ABG

Servo clamp format, 150mm diam., 19 bit resolution, asynchronous serial data, radial connection 100mm long with vertical connector, 12V (cold temperature), Alocrom surface finish, extended thermal stress-screening, very high shock & vibration arrangement.

Zettlex often modify IncOders to specific OEM requirements. Potential changes include :-

- size (up to 595mm outer diameter)
- simplex, duplex or triplex electronics
- mechanical mounts and materials, including stainless steel
- voltage supplies & electrical outputs
- measurement performance
- connectors, cables & immersion protection
- surface finish – black-anodized, natural, painted or SurTec650
- temperature range – notably to -100Celsius and below
- low weight or low inertia
- ATEX certified.

Typically, customised products are an economical option in volumes of >20 units/year for the large size 'Maxi' IncOders. Engineering/tooling charges may apply depending on order quantity.

The image on the right shows a customised, large diameter duplex unit with integral cables for marine application.

To minimise tooling charges, the OD of Stator & Rotor should preferably be based on a size shown below with a corresponding ID. The dimensions of Stator & Rotor should not be less than the dimensions shown below:-

Consult Zettlex or your local representative for further information.

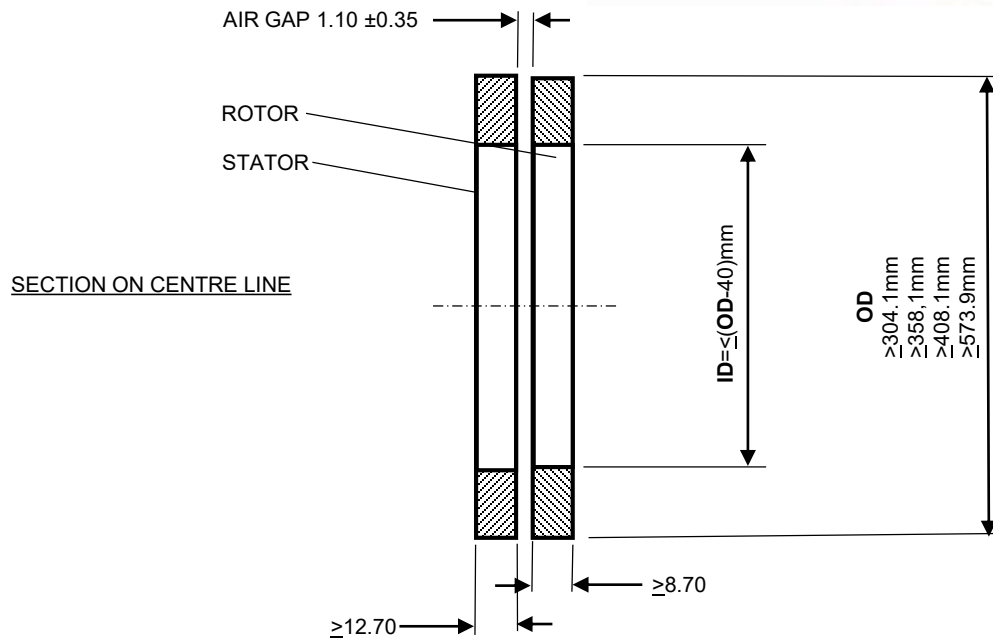

11.1 Standard Cable (8-way) & High Temperature Cable (8-way)

Standard Cable:-

- Product Option INC – CAB3 – 2 (2m long)
- Product Option INC – CAB3 – 5 (5m long)
- Product Option INC – CAB3 – 10 (10m long)

High Temperature Cable:-

- Product Option INC – CAB3 – 2 – HT (2m long)
- Product Option INC – CAB3 – 5 – HT (5m long)
- Product Option INC – CAB3 – 10 – HT (10m long)

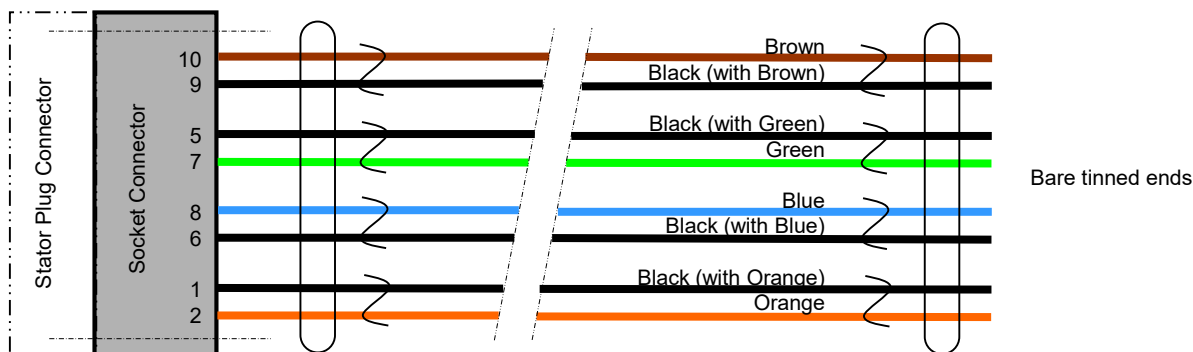

Pair No.	Colour	Connector Pin (For Info. Only)	Signal (SSI1-8 & SPI & BiSS-C)	Signal (ASI1)	Signal (0-5V, 0-10V e)
1	Brown	10	V _{supply}	V _{supply}	V _{supply}
1	Black	9	0V	0V	0V
2	Black	5	Data A	Data A	Signal
2	Green	7	Data B	Data B	Signal Ref.
3	Blue	8	Clock A	Not Used	Span Set
3	Black	6	Clock B	Not Used	Direction Set
4	Black	1	Zero Set	Zero Set	Zero Set
4	Orange	2	Zero Reset	Zero Reset	Reset

- Socket Connector: Harwin DataMate J-Tek 10-way with 2 jack screws, part number M80-461-10-42
- Temperature Rating = -30 to +80Celsius or 105Celsius for High Temp. option
- UL Temperature Rating 80Celsius (UL AWM Style 2464) or 105Celsius for High Temp. option
- Cable diameter = 6mm nominal
- Min. flexing rad. = 76mm with a 1-off bend radius (e.g. on installation) of 20mm
- Cable length = 2, 5 or 10m +/- 0,1m as standard
- Cable sheath & outer jacket = PVC for standard & PTFE for High Temp. option
- Conductors = 24 AWG multi-strand copper wires, twisted pairs, overall foil shield, tinned copper drain wire
- Conductor insulation = polyethylene for standard & PTFE for High Temp. option
- For integral axial cable (Product Option AFL1-52) connection table see Section 3.4.

10.1. How do IncOders work?

IncOders work in a similar way to rotary variable transformers, brushless resolvers or synchros. The Stator receives DC power and produces a low power AC electromagnetic field between the Stator & Rotor. This field is modified by the Rotor depending on its angle. The Stator senses the resulting field and outputs the rotation angle as a digital signal. Unlike resolvers, IncOders use laminar circuits rather than wound wire spools. This technology enables IncOder's compact form, low mass, low inertia and high accuracy without high precision installation.

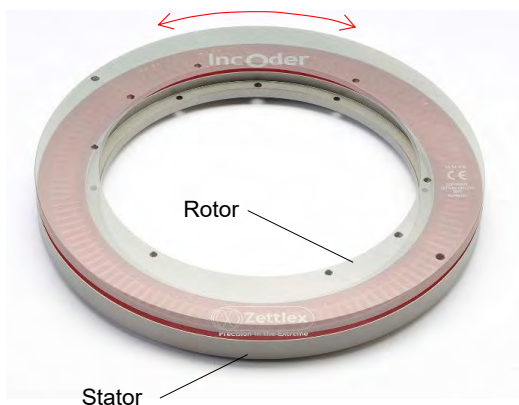

10.2. Is IncOder measurement truly absolute for absolute output devices?

Yes. Measurement will be the same before and after power interruption. No motion is needed at start up.

10.3. Does measurement performance vary with Rotor concentricity?

Resolution, repeatability & accuracy (linearity) will be as specified, provided Rotor concentricity is within specified limits. One might expect accuracy to degrade significantly with concentricity, but IncOders use the full faces of Rotor & Stator, so errors are nulled by diametrically opposing factors. This is different to other encoder technologies – notably optical or capacitive devices - where performance depends on tightly controlled concentricity.

10.4. Can IncOders be used outside the stated operating temperature limits?

Operating temperature limits are set by some of IncOder's electronic parts rather than the basic technique. Standard IncOders are rated -40 or 85°C operation. The Extended Range offers a cold option (Product Options 12VCT or 24VCT) for -60°C or a high temperature option for +105°C (Product Option 5HT). IncOders can be used outside these limits following qualification by the user. At temperatures at or below the stated lower limit, it is recommended to leave the unit powered or allow an extended powered period (>1 minute) before operation.

10.5. What happens if the Rotor or Stator get wet or dirty?

Measurement performance is unaffected by humidity, condensation, dirt, dust, oil, mud or sand. All IncOders will survive temporary immersion to depths of 1m water. Where frequent exposure to liquids, or immersion, is part of the operating environment, units with integral connection and Product Option C should be specified.

10.6. How can an IncOder be calibrated?

Calibration is only relevant for some ultra high accuracy applications such as astronomical telescopes. Readings from an IncOder are stored and compared to a reference in a look-up table in the host system. Such an arrangement will negate any inaccuracy due to inherent non-linearity or installation tolerances. Resolution & repeatability are unaffected by calibration.

10.7. At what Baud rate can the data interface operate at and does this effect cable length?

The longer the transmission distance (Cable Length), the slower the recommended Baud Rate. This table shows recommended Baud Rates vs. Cable Length.

Baud Rates For Data Transmission				
Cable Length (m)	<30	<60	<120	<250
Baud Rate	<400 kHz	<300 kHz	<200kHz	<100 kHz

10.8. Are IncOders affected by magnets?

No. Magnets produce DC fields. IncOders use AC electro-magnetic fields at a highly specific frequency.

10.9. Are IncOders suitable for use in harsh electromagnetic fields?

Yes. Many IncOders are used near powerful sources of electromagnetic noise such as motors or transformers. IncOder's aluminium housing produces a Faraday cage effect around the internal electronics and the technology is designed so that incoming, far-field radiation is self cancelling or filtered out.

10.10. Do IncOders produce electromagnetic emissions?

Radiated emissions are tiny and limited to the IncOder's internal sensor faces. The IncOder housing has a Faraday cage effect. IncOders are often used in proximity to sensitive devices such as navigation aids.

10.11. What if we need to earth the IncOder casing?

Some applications such as fighting vehicles and aircraft require the IncOder casework to be electrically earthed. Some IncOder housing finishes are hard-anodized which is non-conductive. A connection can be made using an earth strap with a crinkle washer which penetrates the anodized surface. Alternatively, remove the anodized surface in the immediate vicinity of the strap (usually located using one of the attaching screws) using a file or abrasive. Alternatively, conductive finishes such as Alocrom or Surtec650 may be specified from the Extended Product Range (standard for 37 and 58mm products).

10.12. Does the Rotor need electrical earthing?

No. Some capacitive devices require the rotating shaft to be electrically connected to earth so as to avoid electrostatic interference. There is no such requirement with IncOder.

10.13. Does measurement performance vary with Rotor to Stator gap?

Resolution, repeatability & linearity will be as specified, provided gap is to specified tolerances. Within limits, the IncOder's measurement resolution & repeatability are independent of gap. If gap tolerance is increased from $\pm 0.35\text{mm}$ to $\pm 0.50\text{mm}$ the *guaranteed* measurement non-linearity will double. For example, if an IncOder has a gap tolerance of $\pm 0.50\text{mm}$ (rather than the specified $+0.35\text{mm}$) the *guaranteed* linearity will increase from $\pm 1\text{Xarc-sec}$ to $\pm 2\text{Xarc-sec}$. Gap tolerances are most easily achieved using Set Screw or Shaft Clamp Rotors. Alternatively the required gap may be maintained by the use of a shim.

10.14. Do IncOders carry out self checks or Built-In-Test (BIT)?

Yes. If BIT shows an internal error then an error signal is generated. The BITs include continuity/damage, presence of Rotor, in-range Rotor, gross electromagnetic malfunction, window watchdog timer, power on reset, power brownout reset, timeouts for clock input, read/write and internal flash data memory value checks.

10.15. Do IncOders outgas?

IncOder housings are hard-anodized, Surtec or Alocrom finished aluminium which produce no outgassing. The epoxies and other materials used inside the devices comply with NASA's classification of low outgassing materials for spacecraft with TML of $<1\%$ and CVM of $<0.1\%$ measured at 125°C over 24 hours in vacuum according to ASTM E-595-90. IncOders are successfully used with sensitive optical devices without residues from the IncOder affecting the lenses.

10.16. How can we specify a custom IncOder variant?

Use this document as a basis and specify any differences. Preferably, a standard outer diameter dimension and a proportionate inner diameter should be used – see Section 7. This enables us to use regular sensor components with an alternative mechanical format.

10.17. What's the largest IncOder you can build?

595mm outer diameter. Contact Zettlex or your local representative for larger sizes.

10.18. Do IncOders require an Export License?

Not usually. IncOders are exempt from Annex I to Council Regulation (EC) No. 428/2009, as amended [EU Dual-Use List] and only require an export license if the diameter is greater than or equal to 1000mm or accuracy is $<1\text{arc-second}$. No standard products are in this class.

10.19. How does Zettlex manage the obsolescence of electronic components?

Zettlex has detailed obsolescence policies and procedures as part of our Quality Management System. Generally, our policy is only to use electronic components which are widely used; available from a variety of sources and have low likelihood of obsolescence. In the event of an electronic component becoming obsolete we typically select, specify and, if necessary, qualify a suitable form, fit & functional alternative.

10.20. Can IncOders be used submerged in oil or water?

Yes. All units can be used in mineral oil. Use integral axial cable connections for submersion in water together with Extended Range Product Option C. If submersion is at depth then also specify Extended Range Product Option C. If necessary, contact Zettlex for further information.

10.21. Does the accuracy of IncOders improve if the range is reduced?

Yes. Repeatability is unaffected but accuracy – in other words, linearity - improves as the range reduces. This can be advantageous in some applications where the range of motion is restricted, such as elevation controls in pointing devices which are often <90°. The following table shows the effect on quoted accuracy as scale reduces for all devices with a digital output:-

IncOder Size mm	Static accuracy. Ranges up to 360° arc-seconds	Static accuracy. Ranges up to 90° arc-seconds	Static accuracy. Ranges up to 60° arc-seconds	Static accuracy. Ranges up to 30° arc-seconds
325	38	36	28	19
379	40	38	30	20
430	45	43	34	23
595	60	57	45	30

The rate of improvement of static accuracy vs. range is not a simple linear function. This means that if your application’s range is say 120° the quoted accuracy should be taken from the column ‘up to 360°’. Similarly if your range is 45° the quoted accuracy should be taken from the column ‘up to 60°’.

10.22. Can we accurately calculate speed using an IncOder?

Yes. There are various approaches and the optimal approach depends on the nature of your application and how accurately speed is to be measured. One option is to use a device with an absolute angle output such as SPI or SSI, and where SPI1 or SSI4 product options are particularly advantageous. The approach is detailed in a separate document - please refer to Zettlex IncOder App Note – Calculating Speed. You can find this in the IncOder section of our web-site (www.zettlex.com) or ask your local Zettlex representative for a copy.

10.23. Does current consumption depend on supply voltage?

No - because we use linear voltage regulators in the IncOder stator.

Australia	Zettlex Ltd., UK, www.zettlex.com +44 (0) 1223 874444
Austria	Zettlex Hamburg Office, www.zettlex.com +49 (0) 40 82217 8935
Belarus	Aviton, Russia www.aviton.spb.ru +7 812 702 1001
Belgium	Zettlex Ltd., UK, www.zettlex.com +44 (0) 1223 874444
Brazil	Zettlex East Coast Office, Boston, USA, www.zettlex.com +1 (0) 857 203 8519
Canada	Zettlex Chicago Office, Chicago, www.zettlex.com +1 (0) 857 203 8519
China (NE & E)	Shanghai Mingcheng Control Technology Ltd. www.shmcct.com
China (SW)	Chongqing Fuleji www.fuleji.net +86 (0) 23 8890 6991
Czech Republic	Z.M.Systems, Slovakia, www.zettlex.com +44 1223 852452
Denmark	Zettlex Hamburg Office, www.zettlex.com +49 (0) 40 82217 8935
Finland	Zettlex Ltd., UK, www.zettlex.com +44 (0) 1223 874444
France	Zettlex Ltd., UK, www.zettlex.com +44 (0) 1223 874444
Germany	Zettlex Hamburg Office, www.zettlex.com +49 (0) 40 82217 8935
Romania	Z.M.Systems, Slovakia, www.zettlex.com +44 1223 852452
India	Sika Interplant Systems Ltd., India www.sikaglobal.com +91 80 25599144
Indonesia	OptoCom, Malaysia, www.optocom.com.my +603 (0) 8706 6806
Israel	Relcom Systems, Israel www.relsys.co.il +972 9 9565070
Italy	Servotecnica SpA, www.servotecnica.com , +39 (0) 362 4921
Japan	Midori Precision Ltd., Japan www.midori.co.jp +81 42 554 5650
Luxembourg	Zettlex Hamburg Office, www.zettlex.com +49 (0) 40 82217 8935
Malaysia	OptoCom, Malaysia, www.optocom.com.my +603 (0) 8706 6806
Mexico	Zettlex West Coast Office, San Mateo, www.zettlex.com +1 (0) 650 378 1257
Netherlands	Zettlex Ltd., UK, www.zettlex.com +44 (0) 1223 874444
New Zealand	Zettlex Ltd., UK, www.zettlex.com +44 (0) 1223 874444
Norway	Zettlex Ltd., UK, www.zettlex.com +44 (0) 1223 874444
Poland	Zettlex Ltd., UK, www.zettlex.com +44 (0) 1223 874444
Portugal	Giza Technologies SAU, Spain, www.gizatech.com , +34 (0) 917 216 630
Romania	Z.M.Systems, Slovakia, www.zettlex.com +44 1223 852452
Russia	Aviton, Russia www.aviton.spb.ru +7 812 702 1001
Singapore	OptoCom, Malaysia, www.optocom.com.my +603 (0) 8706 6806
Slovakia	Z.M.Systems, Slovakia, www.zettlex.com +44 1223 852452
South Africa	Zettlex Ltd., UK, www.zettlex.com +44 (0) 1223 874444
South Korea	SamJeong Automation www.sjautomation.com +82 (0) 31 469 3090
Spain	Giza Technologies SAU, Spain, www.gizatech.com , +34 (0) 917 216 630
Sweden	Zettlex Ltd., UK, www.zettlex.com +44 (0) 1223 874444
Switzerland	Zettlex Hamburg Office, www.zettlex.com +49 (0) 40 82217 8935
Thailand	OptoCom, Malaysia, www.optocom.com.my +603 (0) 8706 6806
USA (East)	Zettlex East Coast Office, Boston, USA, www.zettlex.com +1 (0) 857 203 8519
USA (Mid)	Zettlex Chicago Office, Chicago, www.zettlex.com +1 847 563 2314
USA (West)	Zettlex West Coast Office, San Mateo, www.zettlex.com +1 (0) 650 378 1257

All products available via your local reseller or from the Zettlex web-site at
<http://www.zettlex.com>



Message from Mark Howard, Zettlex General Manager:

Ours is a simple business ethic: hard work, honesty & great customer service. I hope you will find our products useful.

Zettlex UK Ltd.
 Faraday House
 Barrington Road, Foxton
 Cambridge
 CB22 6SL
 United Kingdom
 Tel [+44] 01223 874444
 Fax [+44] 01223 874111
 Email info@zettlex.com
www.zettlex.com

Revision History - 4.11.2 to 4.11.3
o New document.



Distributors for Australia & New Zealand

MOTION TECHNOLOGIES PTY LTD

24/22-30 Northumberland Road
Caringbah NSW 2229 Australia
Phone: (02) 9524 4782
Fax: (02) 9525 3878

sales@motiontech.com.au
www.motiontech.com.au

© 19/03/19

While Zettlex provides application assistance personally, through our literature, web-site and partners, it is the customer's responsibility to determine the suitability of the product in the application.

Specifications may change without notice. Quoted data is derived from test, analysis or design similarity. The information provided by Zettlex in this Product Guide is believed to be accurate and reliable as of this printing, however, Zettlex assumes no responsibility for its use.

WARRANTY/REMEDY

Zettlex warrants goods of its manufacture as being free of defective materials and faulty workmanship for 1 year from date of purchase. Zettlex standard product warranty applies unless agreed otherwise by Zettlex in writing. Please refer to Zettlex or local representative for warranty details. If warranted goods are returned to Zettlex during the warranty period then Zettlex will repair or replace, at its option, without charge those items that it finds defective. The foregoing is the buyer's sole remedy and is in lieu of all other warranties, expressed or implied, including those of merchantability and fitness for a particular purpose. In no event shall Zettlex be liable for consequential, special or indirect damages.



WARNING. PERSONAL INJURY.

Do not use these products as safety or emergency stop devices or in any application where failure of the product could result in personal injury. Failure to comply to these instructions could result in death or serious injury.



WARNING. PERSONAL INJURY.

Do not use these products in any application where there is the potential for combustion or explosion with flammable gases, dust or liquids. Failure to comply to these instructions could result in death or serious injury.