

Worm gear screw jacks

3.2 Structural configurations

3.2.7 SHG range type 1

Type 1 (lifting spindle)

Spiral mitre gear boxes permit high lifting speeds
- high efficient rating and long service life

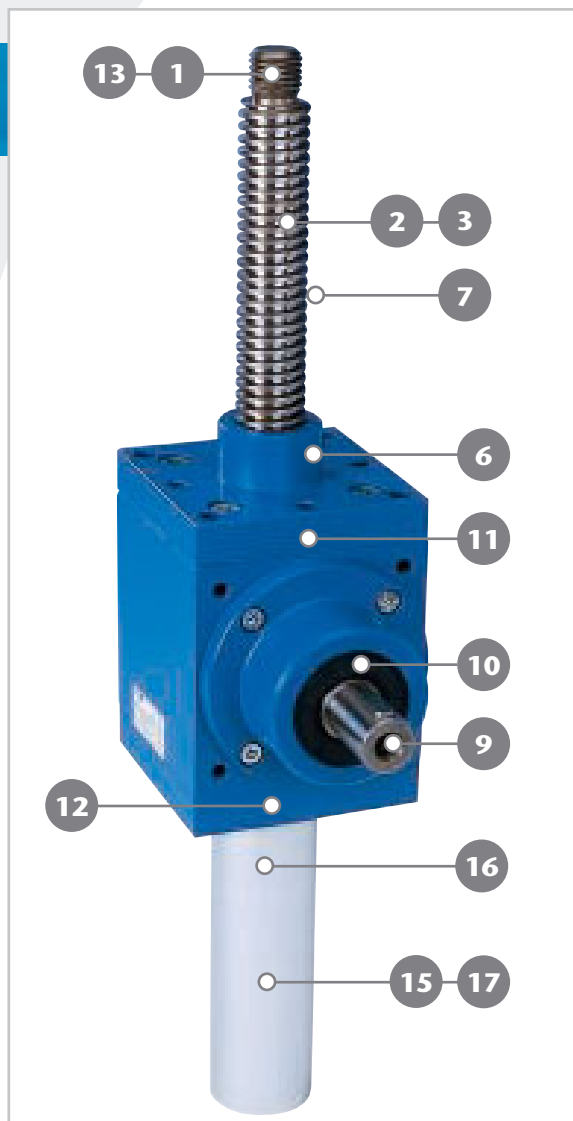

Kits supplied:

- 4 different sizes
- with lifting capacities ranging from 15 kN to 90 kN
- Lifting speeds up to 19 m/min
- Drive-motor speeds of up to 3000 rpm
- Self-locking trapezoidal spindle
- Separate lubricating circuits, Tr spindle with grease lubrication and bevel-gears with oil splash lubrication
- Bevel-gears in two ratio steps
- Depending on requirements (2:1 and 3:1)
- Teeth are case-hardened and ground

3.2.8 SHG range type 2

Type 2 (rotating spindle)

Spiral mitre gear boxes permit high lifting speeds
- high efficient rating and long service life

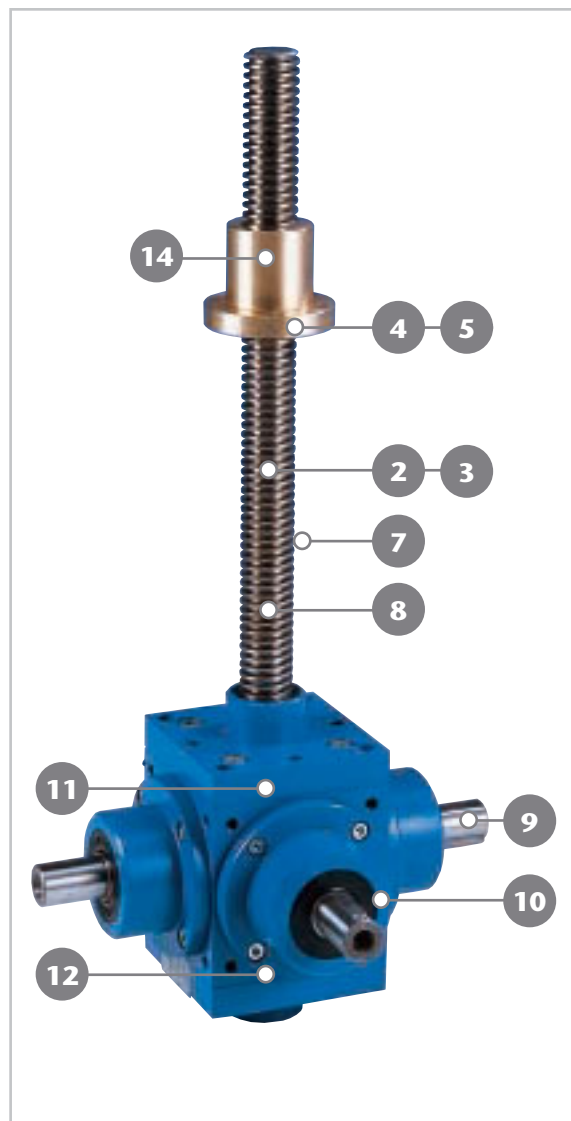

Kits supplied:

- 4 different sizes
- with lifting capacities ranging from 15 kN to 90 kN
- Lifting speeds up to 19 m/min
- Drive-motor speeds of up to 3000 rpm
- Self-locking trapezoidal spindle
- Separate lubricating circuits, Tr spindle with grease lubrication and bevel-gears with oil splash lubrication
- Bevel-gears in two ratio steps
- Depending on requirements (2:1 and 3:1)
- Teeth are case-hardened and ground

Worm gear screw jacks

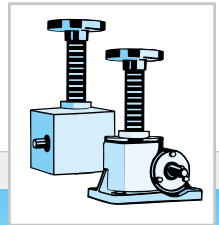

3.2 Structural configurations

3

No.	Symbol	SHG range type 1	SHG range type 2
1		●	
2		●	●
3		●	●
4			●
5			●
6		●	
7		●	●

- SHG of standard configuration
- Options and accessories

No.	Symbol	SHG range type 1	SHG range type 2
8			●
9		●	●
10		●	●
11		●	●
12		●	●
13		●	
14		●	●
15		●	
16		●	
17		●	

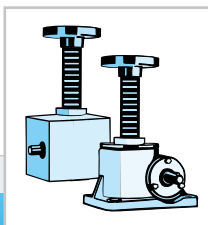

Worm gear screw jacks

3.3 Technical information

3

3.3.1.4 Quick-lifting screw jacks SHG

Size		G 15	G 25	G 50	G 90
Max. lifting force	[kN]	15	25	50	90
Max. tension load	[kN]	15	25	50	90
Spindle Tr ¹⁾		24x5	35x8	40x7	60x9
Ratio N		2:1			
Amount of lift per revolution for ratio N	[mm/U]	2,5	4	3,5	4,5
Ratio L		3:1			
Amount of lift per revolution for ratio L	[mm/U]	1,66	2,67	2,33	3
Max. drive capacity ²⁾ at 20°C	[kW]	1,0	1,5	2,4	8,9
Ambient temp. and 20 % ED/hr					
Max. drive capacity ²⁾ at 20°C	[kW]	1,3	2,6	3,8	13
Ambient temp. and 10 % ED/hr					
Spindle efficiency rating	[%]	41	43	37	33
Torque, capacity, turning-speed at 20 % ED/hr and 20°C		see performance tables 3.3.3.4			
Spindle torque at max. lifting power	[Nm]	29,4	73,2	123,4	398,5
Max. permitted drive-shaft torque	[Nm]	50	125	175	1600
Max. permitted spindle length with compression load	[mm]	see bend diagrams			
Housing material		GG	AlSi10Mg	GG	
Weight without screw jack and protection tube	[kg]	9	13,5	23	85
Spindle weight per 100 mm of lift	[kg]	0,8	0,59	1,5	2,5
Amounts of lubricant in transmission	[kg]	0,15	0,9	0,6	3,5
Mass moment of inertia ³⁾					
N-ratio Type 1	[kg cm ²]	1,058	6,63	22,44	181,28
Mass moment of inertia ³⁾					
N-ratio Type 2	[kg cm ²]	1,079	6,79	22,89	184,92
Mass moment of inertia ³⁾					
L-ratio Type 1	[kg cm ²]	0,677	3,60	7,248	123,79
Mass moment of inertia ³⁾					
L-ratio Type 2	[kg cm ²]	0,691	3,67	7,393	126,28

¹⁾ Also applies to Ku spindle, see section 3.3.7

²⁾ Max. permitted values for type 1 and Tr spindle.

Higher values are possible when using type 2 or Ku spindles.

³⁾ referring to 100 mm spindle length

Worm gear screw jacks

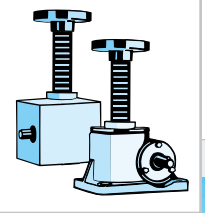

3.3 Technical information

3.3.3.4 SHG range

Turning speed, power requirement and permitted lifting speed for ratio 2:1 and 3:1 with single-threaded, lifting (Type 1) trapezoidal spindle. All performance data are expressed in terms of dynamic lifting force. With load factors of <10%/hr or configuration with rotating spindle (Type 2), the maximum permitted drive capacities can be increased. Please consult our drive-system specialists if this is the case.

3

G 15 spindle Tr 24x5

n [1/min]	Lifting speed [m/min.]	F=15 [kN]				F=12,5 [kN]				F=10 [kN]				F=7,5 [kN]				F=5 [kN]				F=2,5 [kN]				F=1 [kN]			
		2:1		3:1		2:1		3:1		2:1		3:1		2:1		3:1		2:1		3:1		2:1		3:1		2:1		3:1	
		Nm	kW	Nm	kW	Nm	kW	Nm	kW	Nm	kW	Nm	kW	Nm	kW	Nm	kW	Nm	kW	Nm	kW	Nm	kW	Nm	kW	Nm	kW	Nm	kW
3000	7,5 5	16	4,6	12	3,2	14	3,9	10	2,8	11	3,2	8	2,3	8,9	2,6	6,4	1,9	6,5	1,9	5	1,4	4,1	1,2	3,2	1	2,7	0,8	2,3	0,7
2250	5,6 3,75	16	3,5	12	2,4	14	3	10	2,1	11	2,4	8	1,8	8,9	1,9	6,4	1,4	6,5	1,4	5	1,1	4,1	0,9	3,2	0,7	2,7	0,6	2,3	0,5
1500	3,75 2,5	16	2,3	12	1,6	14	2	10	1,4	11	1,6	8	1,2	8,9	1,3	6,4	1	6,5	1	5	0,7	4,1	0,6	3,2	0,5	2,7	0,4	2,3	0,4
1000	2,5 1,67	16	1,6	12	1,1	14	1,3	10	1	11	1,1	8	0,8	8,9	0,9	6,4	0,7	6,5	0,7	5	0,5	4,1	0,4	3,2	0,4	2,7	0,3	2,3	0,3
750	1,88 1,25	16	1,2	12	0,8	14	1	10	0,7	11	0,8	8	0,6	8,9	0,7	6,4	0,5	6,5	0,5	5	0,4	4,1	0,3	3,2	0,3	2,7	0,2	2,3	0,2
500	1,25 0,83	16	0,8	12	0,6	14	0,7	10	0,5	11	0,6	8	0,4	8,9	0,5	6,4	0,3	6,5	0,4	5	0,3	4,1	0,2	3,2	0,2	2,7	0,2	2,3	0,1
250	0,63 0,42	16	0,4	12	0,3	14	0,4	10	0,3	11	0,3	8	0,2	8,9	0,3	6,4	0,2	6,5	0,2	5	0,2	4,1	0,1	3,2	0,1	2,7	0,1	2,3	0,1

G 25 spindle Tr 35x8

n [1/min]	Lifting speed [m/min.]	F=25 [kN]				F=20 [kN]				F=15 [kN]				F=10 [kN]				F=5 [kN]				F=2,5 [kN]				F=1 [kN]			
		2:1		3:1		2:1		3:1		2:1		3:1		2:1		3:1		2:1		3:1		2:1		3:1		2:1		3:1	
		Nm	kW	Nm	kW	Nm	kW	Nm	kW	Nm	kW	Nm	kW	Nm	kW	Nm	kW	Nm	kW	Nm	kW	Nm	kW	Nm	kW	Nm	kW	Nm	kW
3000	12 8	40	13	28	8,6	33	10	23	7	25	7,8	18	5,6	18	5,5	13	3,9	10	3,2	8	2,4	7	2	6	1,6	5	1,3	4	1,1
2250	9 6	40	9,4	28	6,5	33	7,7	23	5,4	25	5,9	18	4,2	18	4,2	13	3	10	2,4	8	1,9	7	1,6	6	1,3	5	1	4	0,9
1500	6 4	40	6,3	28	4,4	33	5,2	23	3,6	25	4	18	2,8	18	2,8	13	2,1	10	1,7	8	1,3	7	1,1	6	0,9	5	0,7	4	0,7
1000	4 2,6	40	4,2	28	2,9	33	3,5	23	2,4	25	2,7	18	1,9	18	1,9	13	1,4	10	1,1	8	0,9	7	0,7	6	0,6	5	0,5	4	0,5
750	3 2	40	3	28	2,1	33	2,5	23	1,7	25	1,9	18	1,3	18	1,3	13	0,9	10	0,7	8	0,5	7	0,4	6	0,3	5	0,3	4	0,2
500	2 1,3	40	2	28	1,4	33	1,6	23	1,1	25	1,3	18	0,9	18	0,9	13	0,6	10	0,5	8	0,4	7	0,3	6	0,2	5	0,2	4	0,2
250	1 0,6	40	1,1	28	0,7	33	0,9	23	0,6	25	0,7	18	0,5	18	0,5	13	0,4	10	0,3	8	0,2	7	0,2	6	0,2	5	0,1	4	0,1

G 50 spindle Tr 40x7

n [1/min]	Lifting speed [m/min.]	F=50 [kN]				F=30 [kN]				F=20 [kN]				F=15 [kN]				F=10 [kN]				F=5 [kN]				F=2,5 [kN]			
		2:1		3:1		2:1		3:1		2:1		3:1		2:1		3:1		2:1		3:1		2:1		3:1		2:1		3:1	
		Nm	kW	Nm	kW	Nm	kW	Nm	kW	Nm	kW	Nm	kW	Nm	kW	Nm	kW	Nm	kW	Nm	kW	Nm	kW	Nm	kW	Nm	kW	Nm	kW
3000	10,5 7	80	22	54	15	48	14	33	9,3	33	9,3	23	6,4	26	7,1	18	5	18	5	13	3,5	11	2,8	8	2,1	7	1,8	5,2	1,4
2250	7,9 5,25	80	16	54	11	48	10	33	7	33	7	23	4,8	26	5,4	18	3,7	18	3,7	13	2,7	11	2,1	8	1,6	7	1,3	5,2	1,1
1500	5,2 3,5	80	11	54	7,5	48	6,8	33	4,7	33	4,7	23	3,2	26	3,6	18	2,5	18	2,5	13	1,8	11	1,4	8	1,1	7	0,9	5,2	0,7
1000	3,5 2,3	80	7,5	54	5	48	4,6	33	3,1	33	3,1	23	2,2	26	2,4	18	1,7	18	1,7	13	1,2	11	1	8	0,7	7	0,6	5,2	0,5
750	2,6 1,75	80	5	54	3,8	48	3,4	33	2,3	33	2,4	23	1,6	26	1,8	18	1,3	18	1,3	13	0,9	11	0,7	8	0,6	7	0,5	5,2	0,4
500	1,75 1,17	80	3,8	54	2,5	48	2,3	33	1,6	33	1,6	23	1,1	26	1,2	18	0,9	18	0,9	13	0,6	11	0,5	8	0,4	7	0,3	5,2	0,3
250	0,87 0,58	80	1,9	54	1,4	48	1,2	33	0,8	33	0,8	23	0,6	26	0,6	18	0,5	18	0,5	13	0,3	11	0,3	8	0,2	7	0,2	5,2	0,2

G 90 spindle Tr 60x9

n [1/min]	Lifting speed [m/min.]	F=90 [kN]				F=75 [kN]				F=50 [kN]				F=25 [kN]				F=10 [kN]				F=5 [kN]				F=2,5 [kN]			
		2:1		3:1		2:1		3:1		2:1		3:1		2:1		3:1		2:1		3:1		2:1		3:1		2:1		3:1	
		Nm	kW	Nm	kW	Nm	kW	Nm	kW	Nm	kW	Nm	kW	Nm	kW	Nm	kW	Nm	kW	Nm	kW	Nm	kW	Nm	kW	Nm	kW	Nm	kW
3000	13,5 9	207	58	140	39	174	49	118	33	119	33	81	22	63	17	44	12	30	7,6	22	5,5	19	4,5	14	3,4	14	2,9	10	2,4
2250	10,1 6,75	207	44	140	29	174	37	118	25	119	25	81	17	63	13	44	8,9	30	5,7	22	4,1	19	3,4	14	2,6	14	2,2	10	1,8
1500	6,75 4,5	207	29	140	20	174	24	118	16	119	16	81	11	63	8,5	44	5,9	30	3,8	22	2,8	19	2,3	14	1,7	14	1,5	10	1,2
1000	4,5 3	207	19	140	13	174	16	118	11	119	11	81	7,5	63	5,7	44	4	30	2,6	22	1,9	19	1,5	14	1,2	14	1	10	0,8
750	3,37 2,25	207	15	140	10	174	12	118	8,2	119	8,2	81	5,6	63	4,3	44	3	30	1,9	22	1,4	19	1,1	14	0,9	14	0,8	10	0,6
500	2,25 1,5	207	9,7	140	6,6	174	8,1	118	5,5	119	5,5	81	3,8	63	2,9	44	2	30	1,3	22	1	19	0,8	14	0,6	14	0,5	10	0,4
250	1,12 0,75	207	4,9	140	3,3	174	4,1	118	2,8	119	2,8	81	1,9	63	1,5	44	1	30	0,7	22	0,5	19	0,4	14	0,3	14	0,3	10	0,2

20% ED / 1hr or 30% ED / 10min. and ambient temperature 20°C

static only
(dynamic not permitted)

10% ED/1hr
and ambient temperature 20°C

Worm gear screw jacks

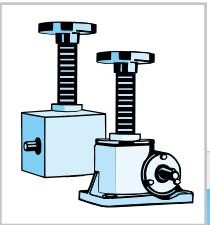

3.3 Technical information

3.3.4.2 Ku range of quick-lifting bevel screw jacks

Turning speed, power requirement and permitted lifting speed for ration „N“ with lifting (Type 1) ball-screw spindle. All performance data are expressed in

terms of dynamic lifting force with 20% ED/hr. Ku spindles with a higher load capacity are possible with configuration type 2.

3

G 15 spindle Ku 25x5

n [1/min]	Lifting speed [m/min.]	F=15 [kN]		F=9,5 [kN]		F=7 [kN]		F=5 [kN]		F=3 [kN]		F=2 [kN]		F=1 [kN]	
		25x5		25x5		25x5		25x5		25x5		25x5		25x5	
Ku 25x		Nm	kW	Nm	kW	Nm	kW	Nm	kW	Nm	kW	Nm	kW	Nm	kW
3000	5	11	3,1	8	2,2	6,2	1,8	5	1,5	4	1,2	3,3	1	2,7	0,8
2500	7,5	11	2,6	8	1,9	6,2	1,5	5	1,2	4	1	3,3	0,8	2,7	0,7
2000	6,25	11	2,1	8	1,5	6,2	1,2	5	1	4	0,8	3,3	0,7	2,7	0,6
1500	5	11	1,6	8	1,1	6,2	0,9	5	0,8	4	0,6	3,3	0,5	2,7	0,4
1000	3,75	11	1,1	8	0,8	6,2	0,6	5	0,5	4	0,4	3,3	0,4	2,7	0,3
750	2,5	11	0,8	8	0,6	6,2	0,5	5	0,4	4	0,3	3,3	0,3	2,7	0,2

G 25 spindle Ku 25x10; 25x5

n [1/min]	Lifting speed [m/min.]	F=25 [kN]				F=20 [kN]				F=15 [kN]				F=10 [kN]				F=5 [kN]				F=2,5 [kN]				F=1 [kN]			
		25x10		25x5		25x10		25x5		25x10		25x5		25x10		25x5		25x10		25x5		25x10		25x5		25x10		25x5	
Ku 25x		Nm	kW	Nm	kW	Nm	kW	Nm	kW	Nm	kW	Nm	kW	Nm	kW	Nm	kW	Nm	kW	Nm	kW	Nm	kW	Nm	kW	Nm	kW		
3000	15,0	25	7,8	14	4,3	21	6,4	12	3,6	16	5	9,5	2,9	12	3,6	7	2,2	5	1,5	5	1,5	3,8	1,2	3,5	1,1	3,1	1		
2500	12,5	25	6,5	14	3,6	21	5,4	12	3,1	16	4,2	9,5	2,5	12	3,1	7	1,9	5	1,3	5	1,3	3,8	1	3,5	1	3,1	0,9		
2000	10	25	5,3	14	3	21	4,4	12	2,5	16	3,4	9,5	2	12	2,5	7	1,6	5	1,1	5	1,1	3,8	0,9	3,5	0,8	3,1	0,7		
1500	7,5	25	4	14	2,2	21	3,3	12	1,9	16	2,6	9,5	1,5	12	1,9	7	1,2	5	0,8	5	0,8	3,8	0,7	3,5	0,6	3,1	0,6		
1000	5	25	2,7	14	1,5	21	2,2	12	1,3	16	1,7	9,5	1	12	1,3	7	0,8	5	0,6	5	0,6	3,8	0,5	3,5	0,4	3,1	0,4		
750	3,8	25	1,9	14	1	21	1,5	12	0,8	16	1,2	9,5	0,6	12	0,8	7	0,5	5	0,3	5	0,3	3,8	0,2	3,5	0,2	3,1	0,2		

G 50 spindle Ku 32x10; 40x5

n [1/min]	Lifting speed [m/min.]	F=40 [kN]				F=25 [kN]				F=20 [kN]				F=15 [kN]				F=10 [kN]				F=5 [kN]				F=2,5 [kN]			
		32x10		40x5		32x10		40x5		32x10		40x5		32x10		40x5		32x10		40x5		32x10		40x5		32x10		40x5	
Ku 32/40x		Nm	kW	Nm	kW	Nm	kW	Nm	kW	Nm	kW	Nm	kW	Nm	kW	Nm	kW	Nm	kW	Nm	kW	Nm	kW	Nm	kW	Nm	kW		
3000	15,0	48	14	26	7,2	31	8,9	17	4,8	25	7,2	14	3,9	20	5,6	14	3,1	14	3,9	9	2,3	8	2,3	5,6	1,5	5	1,5	4,1	1,1
2500	12,5	48	12	26	6	31	7,4	17	4	25	6	14	3,3	20	4,7	14	2,6	14	3,3	9	1,9	8	1,9	5,6	1,2	5	1,2	4,1	0,9
2000	10	48	9,2	26	4,8	31	5,8	17	3,2	25	4,8	14	2,6	20	3,7	14	2,1	14	2,6	9	1,5	8	1,6	5,6	1	5	1	4,1	0,7
1500	7,5	48	6,9	26	3,6	31	4,4	17	2,4	25	3,6	14	2	20	2,8	14	1,6	14	2	9	1,2	8	1,2	5,6	0,8	5	0,8	4,1	0,6
1000	5	48	4,6	26	2,4	31	3	17	1,6	25	2,4	14	1,3	20	1,9	14	1,1	14	1,3	9	0,8	8	0,8	5,6	0,5	5	0,5	4,1	0,4
750	3,8	48	3,5	26	1,8	31	2,3	17	1,2	25	1,9	14	1	20	1,4	14	0,8	14	1	9	0,6	8	0,6	5,6	0,4	5	0,4	4,1	0,3

G 90 spindle Ku 63x10

n [1/min]	Lifting speed [m/min.]	F=90 [kN]		F=60 [kN]		F=40 [kN]		F=20 [kN]		F=15 [kN]		F=10 [kN]		F=5 [kN]	
		63x10		63x10		63x10		63x10		63x10		63x10		63x10	
Ku 63x		Nm	kW	Nm	kW	Nm	kW	Nm	kW	Nm	kW	Nm	kW	Nm	kW
3000	15	116	32	80	23	55	16	30	8,3	25	6,7	19	4,8	13	3,1
2500	12,5	116	28	80	19	55	13	30	7	25	5,5	19	4	13	2,6
2000	10	116	22	80	15	55	11	30	5,6	25	4,4	19	3,2	13	2
1500	7,5	116	17	80	12	55	8	30	4,2	25	3,3	19	2,4	13	1,5
1000	5	116	11	80	7,5	55	5,1	30	2,8	25	2,2	19	1,6	13	1
750	3,8	116	8,4	80	5,7	55	4	30	2,1	25	1,7	19	1,2	13	0,8

Service life of ball-screw spindle > 500 hours
 static only (dynamic not permitted)
 Service life of ball-screw spindle 100 to 500 hours

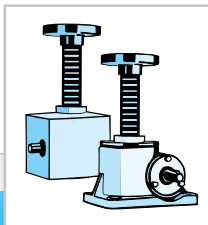

Worm gear screw jacks

3.3 Technical information

3.3.5.4 Spindle efficiency ratings η_{sp} (steel/bronze lubricated)

Tr spindle	14x4	18x6	18x4	20x4	22x5	26x6,28	30x6	35x8	40x7
Spindle efficiency rating[%]	49	54	42,5	40	43	45	40	43	36,5
Tr spindle	40x8	50x9	58x12	60x12	60x9	65x12	70x10	70x12	80x10
Spindle efficiency rating[%]	40	37	40,5	39,5	32,5	37,5	31,6	35,5	29
Tr spindle	90x16	100x10	100x16	120x14	120x16	140x20	160x20	190x24	220x28
Spindle efficiency rating[%]	36,5	24	34	28	30	31,6	28,5	28,8	29

3.3.6 Critical spindle turning speed

The critical turning speed (only configuration type 2) is dependent on the spindle diameter, the spindle length and the spindle bearing (see case 1-4).

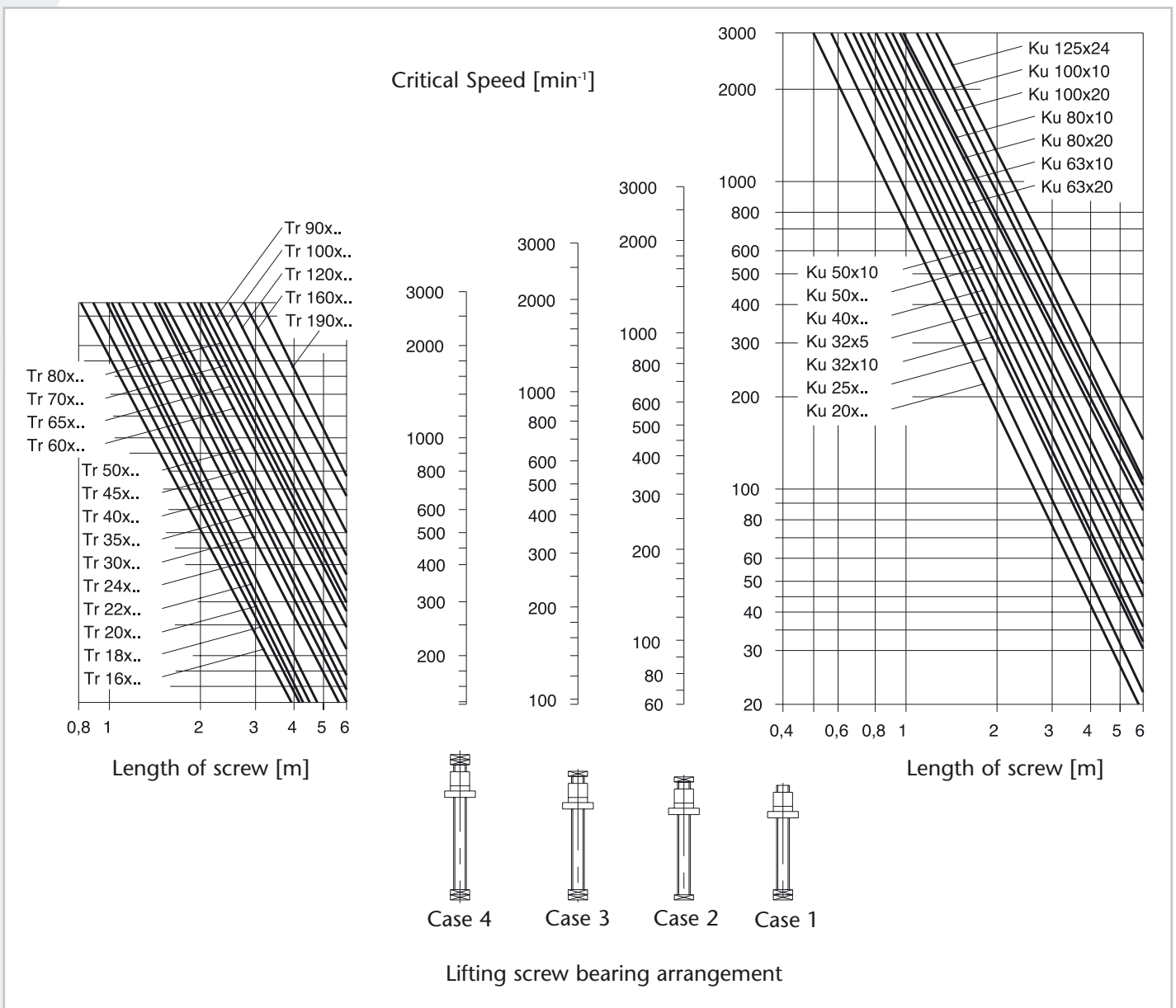

Worm gear screw jacks

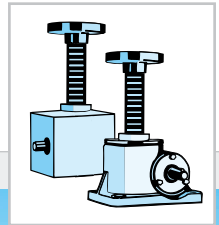

3.3 Technical information

3.3.7 Ball screw spindle Ku

Standard dimensions and load capacities for configuration type 1. Other pitches and load capacities on request. Reinforced spindles with other pitches and higher load capacities can be used with configuration type 2.

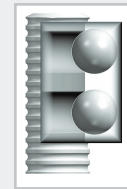

SHE range

Size	Ku spindle	C _{dyn} [kN]	C _{stat} [kN]
2,5	25 x 5	24,1	49,9
	25 x 10	14,8	27,2
5	32 x 5	27,0	75,1
	32 x 10	16,6	42,4
10	50 x 5	111,5	326,8
	50 x 24	44,2	72,9
15	50 x 5	111,5	326,8
	50 x 24	44,2	72,9
20	50 x 5	111,5	326,8
	50 x 24	44,2	72,9
25	80 x 10	134,6	575,4
	63 x 20	92,1	288,8
35	100 x 10	145,9	735,5
	80 x 20	145,9	735,5
50	125 x 10	157,6	931,5
	100 x 20	304,4	1041
75	on request	on request	on request
100	160 x 20	172,9	1216
	125 x 24	328,1	1601

Merkur range

Size	Ku spindle	C _{dyn} [kN]	C _{stat} [kN]
M 0			
M 1	16 x 5	7	12,7
M 2	20 x 5	8	17
M 3	25 x 5	9,5	22,7
M 4	40 x 5	19	63,5
	40 x 10	30	70
M 5	50 x 10	55	153
M 6	80 x 10	69	260
M 7			
M 8			

$$\eta_{sp} \approx 0,9$$

HSE range

Size	Ku spindle	C _{dyn} [kN]	C _{stat} [kN]
36	20 x 5	19,3	23,1
	20 x 10	11,19	14,5
50	32 x 5	27,0	75,1
	32 x 10	27,0	75,1
63	40 x 10	78,7	170,5
	40 x 24	48,4	85,2
80	63 x 10	136	511
	50 x 24	158	247,3
100	80 x 10	134,6	575,4
	63 x 20	92,1	288,8
125	100 x 20	304,4	1041
	80 x 20	280,5	798,3
140	125 x 10	157,6	931,5
	100 x 20	304,4	1041
200	160 x 20	172,9	1216
	125 x 24	328,1	1601

SHG range

Size	Ku spindle	C _{dyn} [kN]	C _{stat} [kN]
G 15	25 x 5	9,5	22,4
G 25	25 x 5	24,1	49,9
	25 x 10	19,7	40,8
G 40	40 x 5	19	63,5
	32 x 10	25,7	56
G 90	63 x 10	60	200

Further Ku spindles on request.
Please ask for a copy!

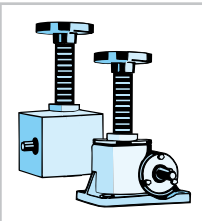

3.7	SHG range dimension plans	103-111
3.7.1	Type 1	104-107
3.7.1.1	Size G 15	104
3.7.1.2	Size G 25	105
3.7.1.3	Size G 50	106
3.7.1.4	Size G 90	107
3.6.2	Type 2	108-111
3.7.2.1	Size G 15	108
3.7.2.2	Size G 25	109
3.7.2.3	Size G 50	110
3.7.2.4	Size G 90	111
3.8	Special travelling nut dimension plans	112-114
3.8.1	LWZ Travelling nut with trunnion	112
3.8.1.1	SHE range	112
3.8.1.2	Merkur range	112
3.8.1.3	HSE range	112
3.8.2	EFM single flange nut for Ku spindle	113
3.8.3	LSF Travelling nut with flat surface	114
3.8.4	LSA Travelling nut with spherical support	114
3.9	Installation locations, shaft/attachment side	115/116
3.9.1	SHE range	115
3.9.2	Merkur range	115
3.9.3	HSE range	116
3.9.4	SHG range	116
3.10	Ordering details	117-118
3.10.1	SHE range	117
3.10.2	Merkur range	117
3.10.3	HSE range	117
3.10.4	SHG range	118
3.10.4.1	Size G15 / G50 / G90	118
3.10.4.2	Size G25	118

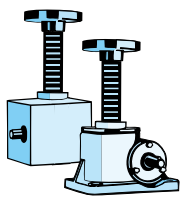

Worm gear screw jacks

3.7 SHG range dimension plans

3.7.1 Type 1

3.7.1.1 Size G 15

3

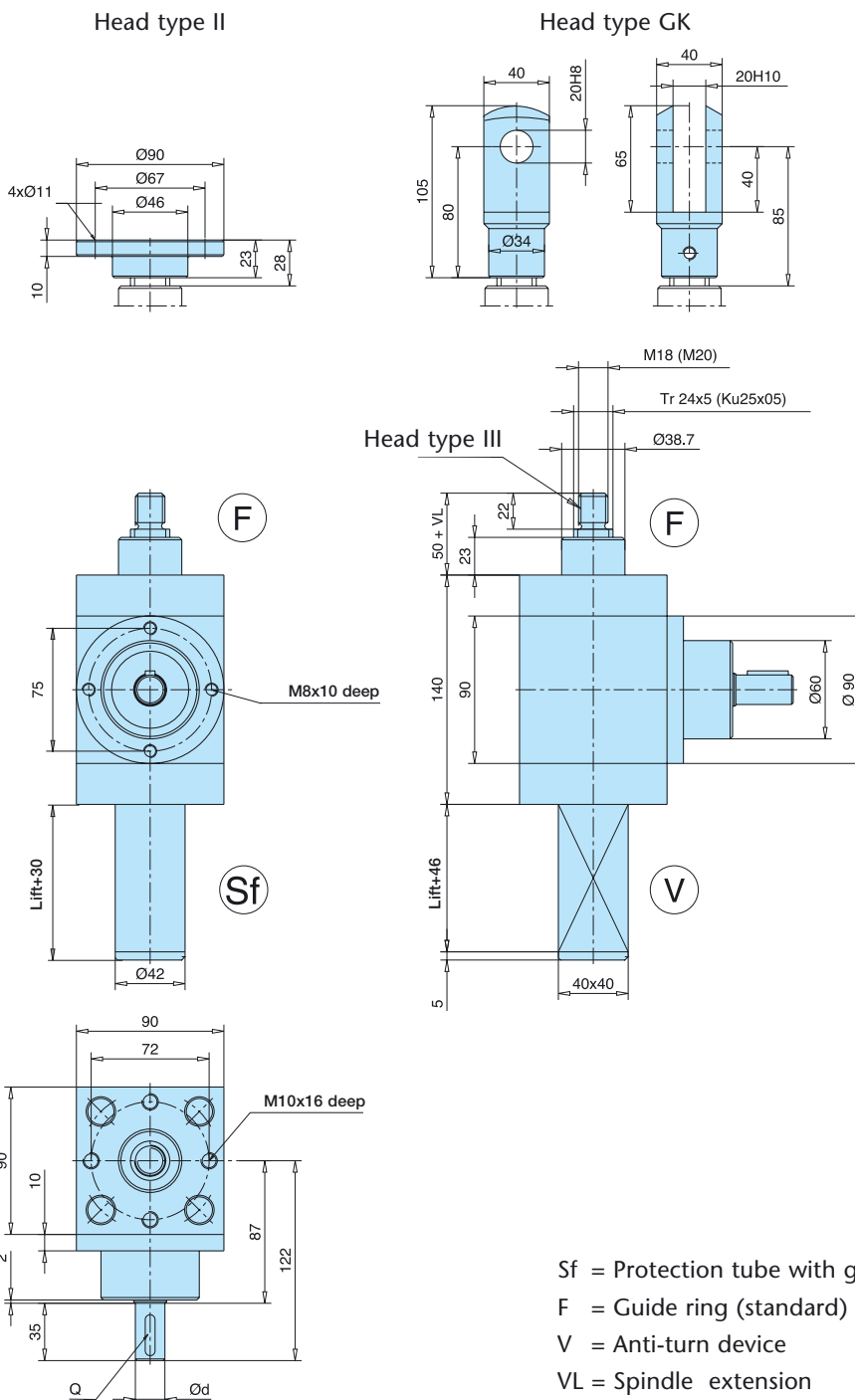

() values in brackets apply for configuration with Ku spindle

Ratio	$\text{Ø}d$ j6	Q (DIN 6885)
2:1	18	A 6x6x25
3:1	12	A 4x4x25

Worm gear screw jacks

3.7 SHG range dimension plans

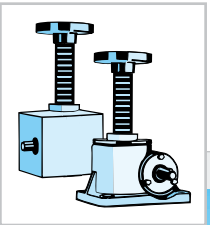

3.7.1.2 Size G 25

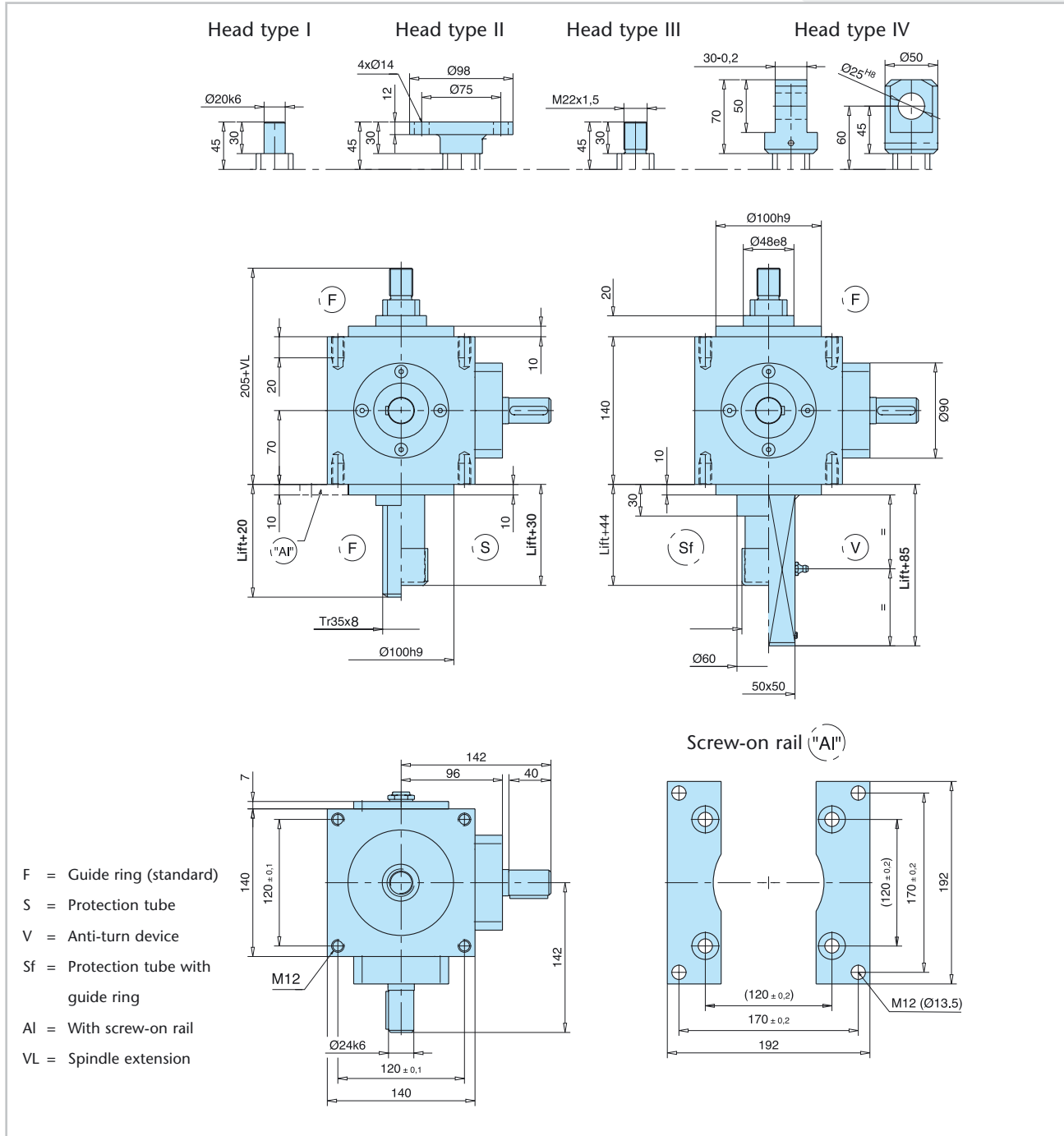

- Options:**
 Dimension plans of the options available on request
- 1) Stroke shutoff
 - 2) Anti-turn device with stroke shutoff
 - 3) Long safety nut (VBG 14)
 - 4) Ball-screw spindle

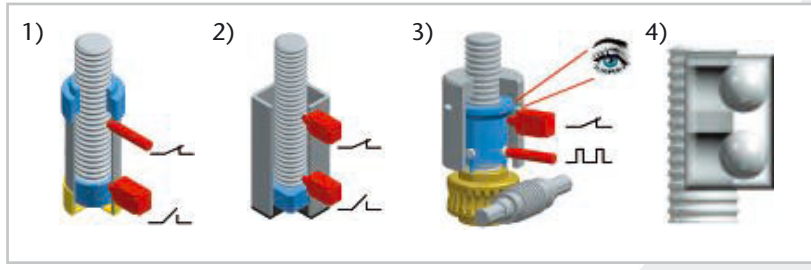

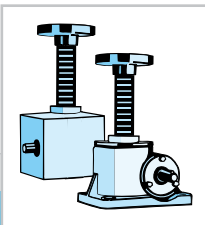

Worm gear screw jacks

3.7 SHG range dimension plans

3.7.1.3 Size G 50

3

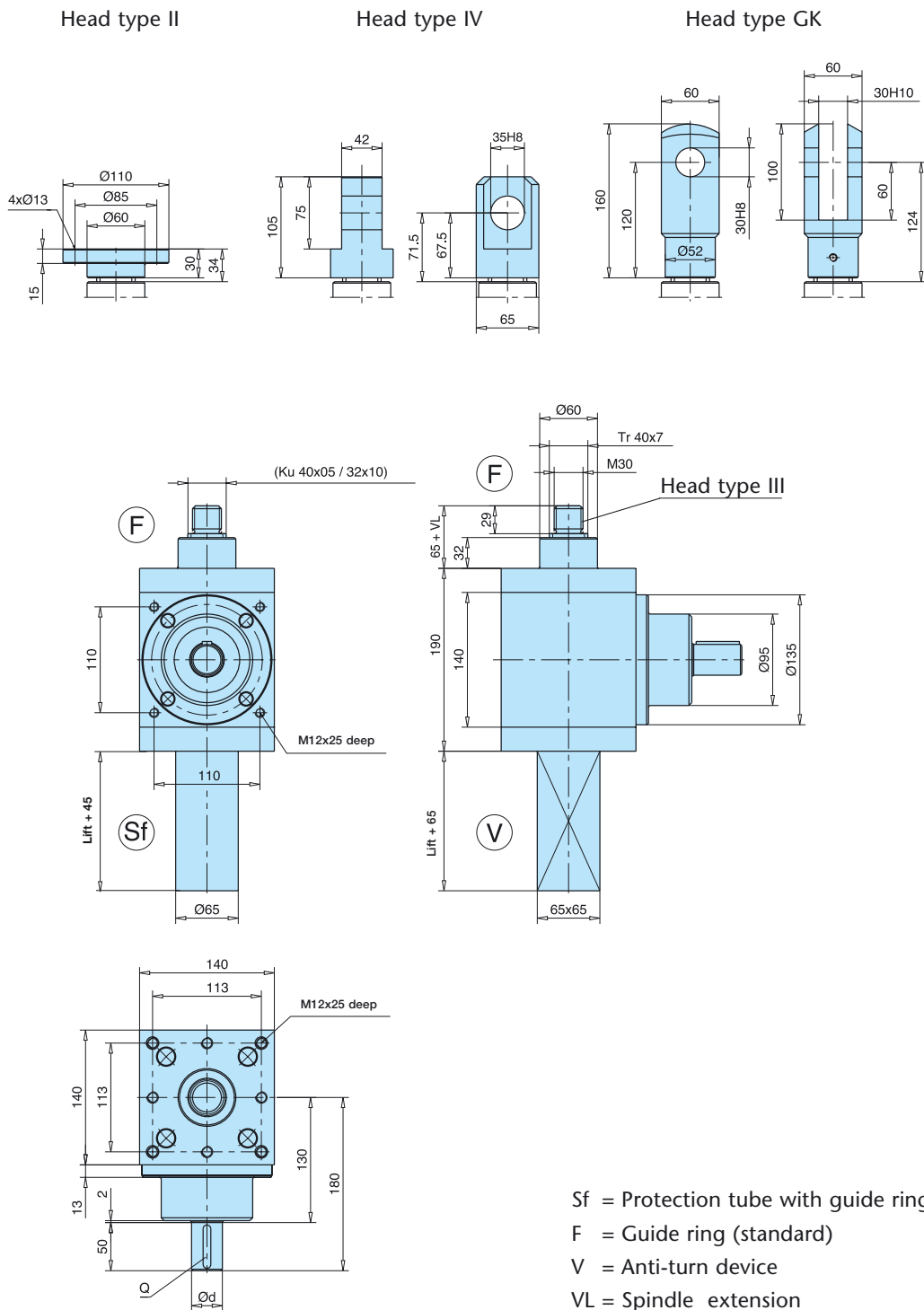

Ratio	Ød j6	Q (DIN 6885)
2:1	32	A 10x8x45
3:1	28	A 8x7x45

Worm gear screw jacks

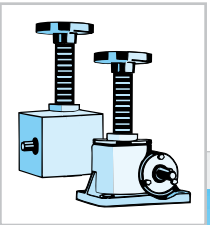

3.7 SHG range dimension plans

3.7.1.4 Size G 90

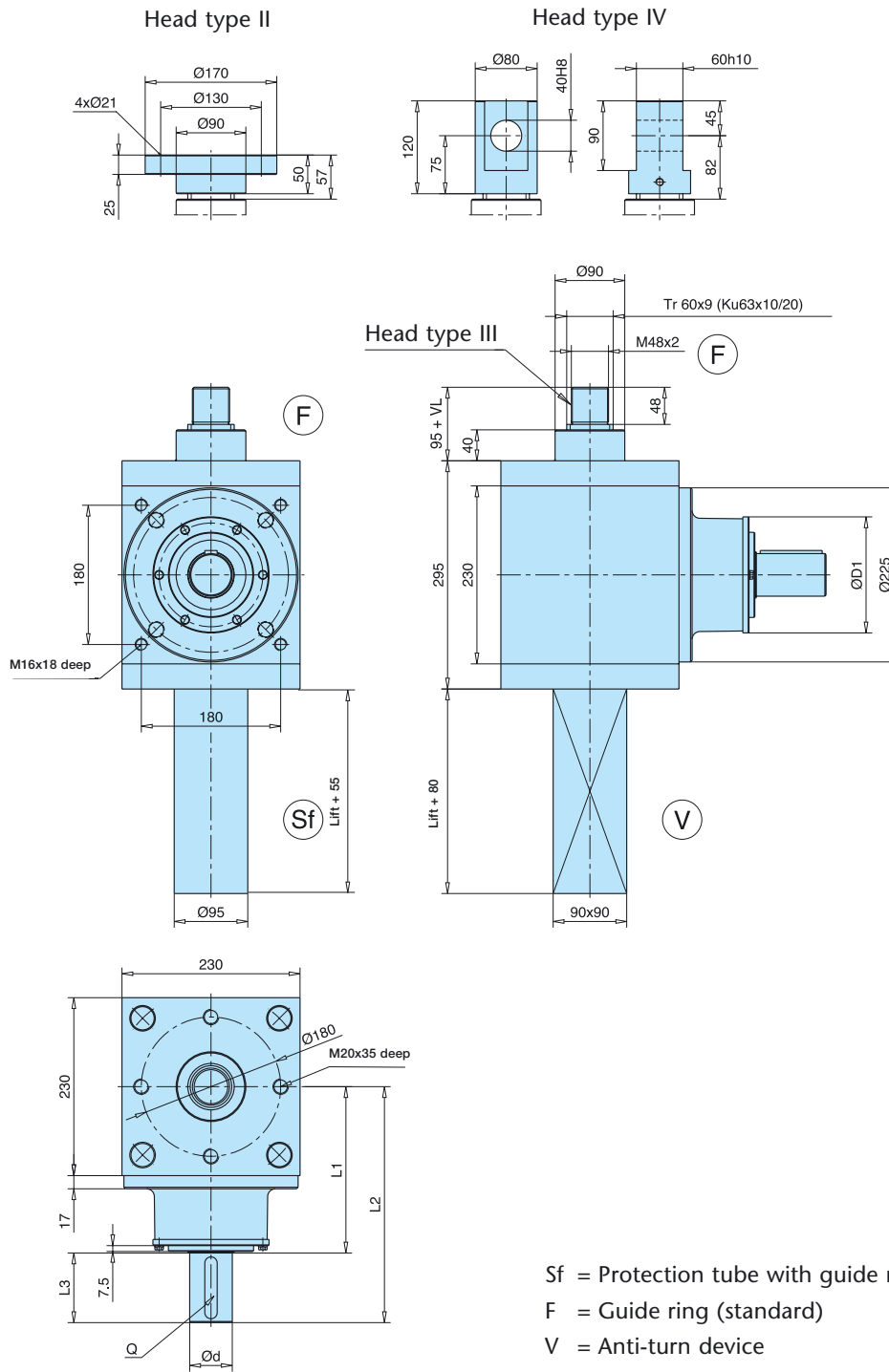

Ratio	$\text{Ø}d \text{ j6}$	$\text{Ø}D1$	L1	L2	L3	Q (DIN 6885)
2:1	55	150	215	305	90	A 16x10x80
3:1	40	120	230	310	80	A 12x8x60

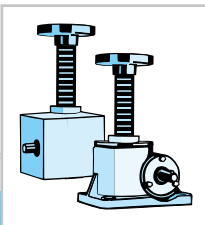

Worm gear screw jacks

3.7 SHG range dimension plans

3.7.2 Type 2

3.7.2.1 Size G 15

3

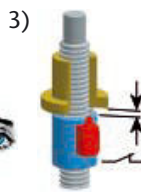
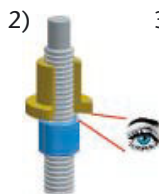
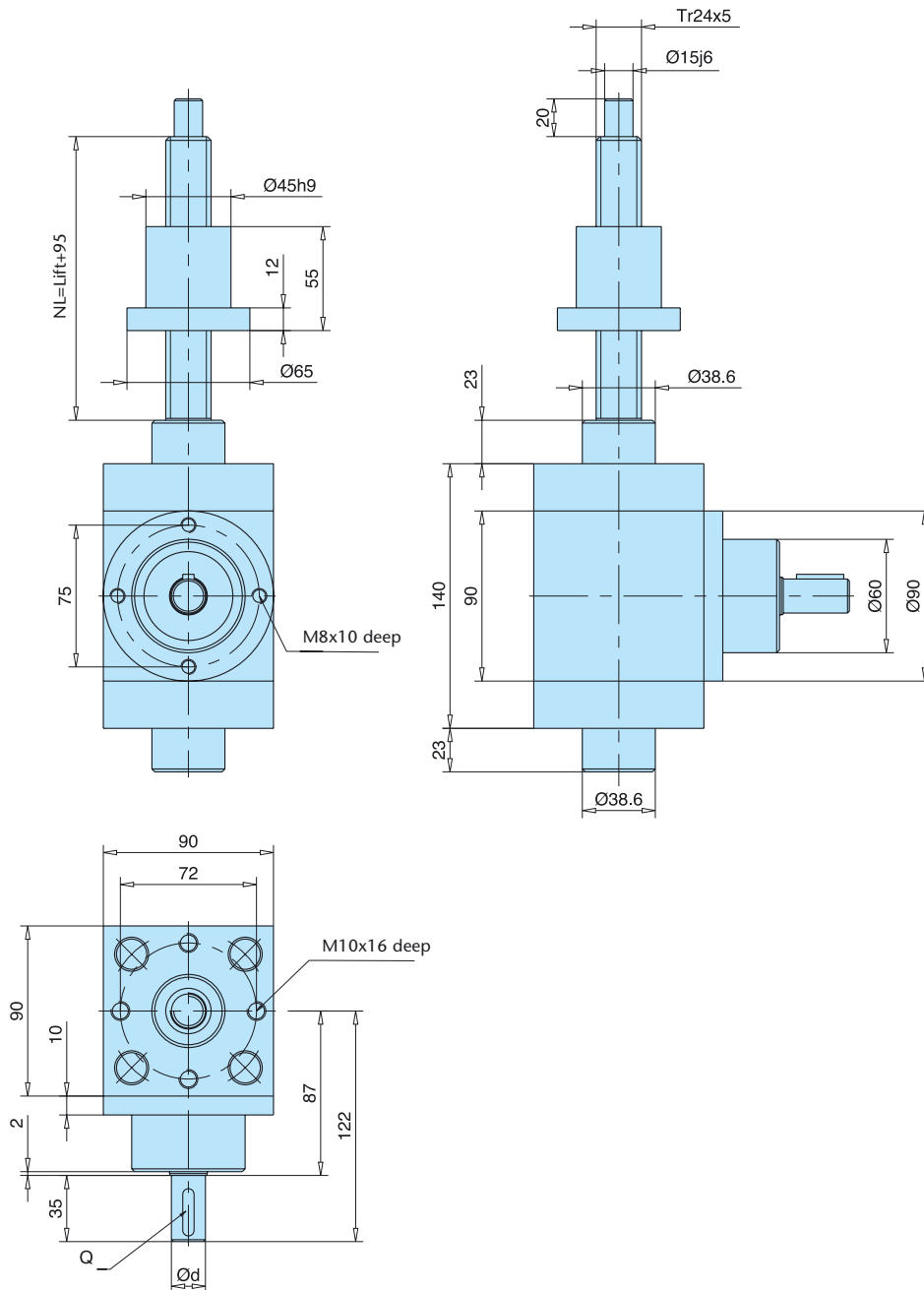

Options:

Dimension plans of the options available on request

- 1) Ball-screw spindle
Flange nut (see section 3.8.2)
- 2) Short safety nut
- 3) Long safety nut

Ratio	Ød j6	Q (DIN 6885)
2:1	18	A 6x6x25
3:1	12	A 4x4x25

Worm gear screw jacks

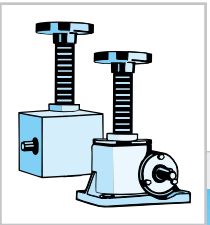

3.7 SHG range dimension plans

3.7.2.2 Size G 25

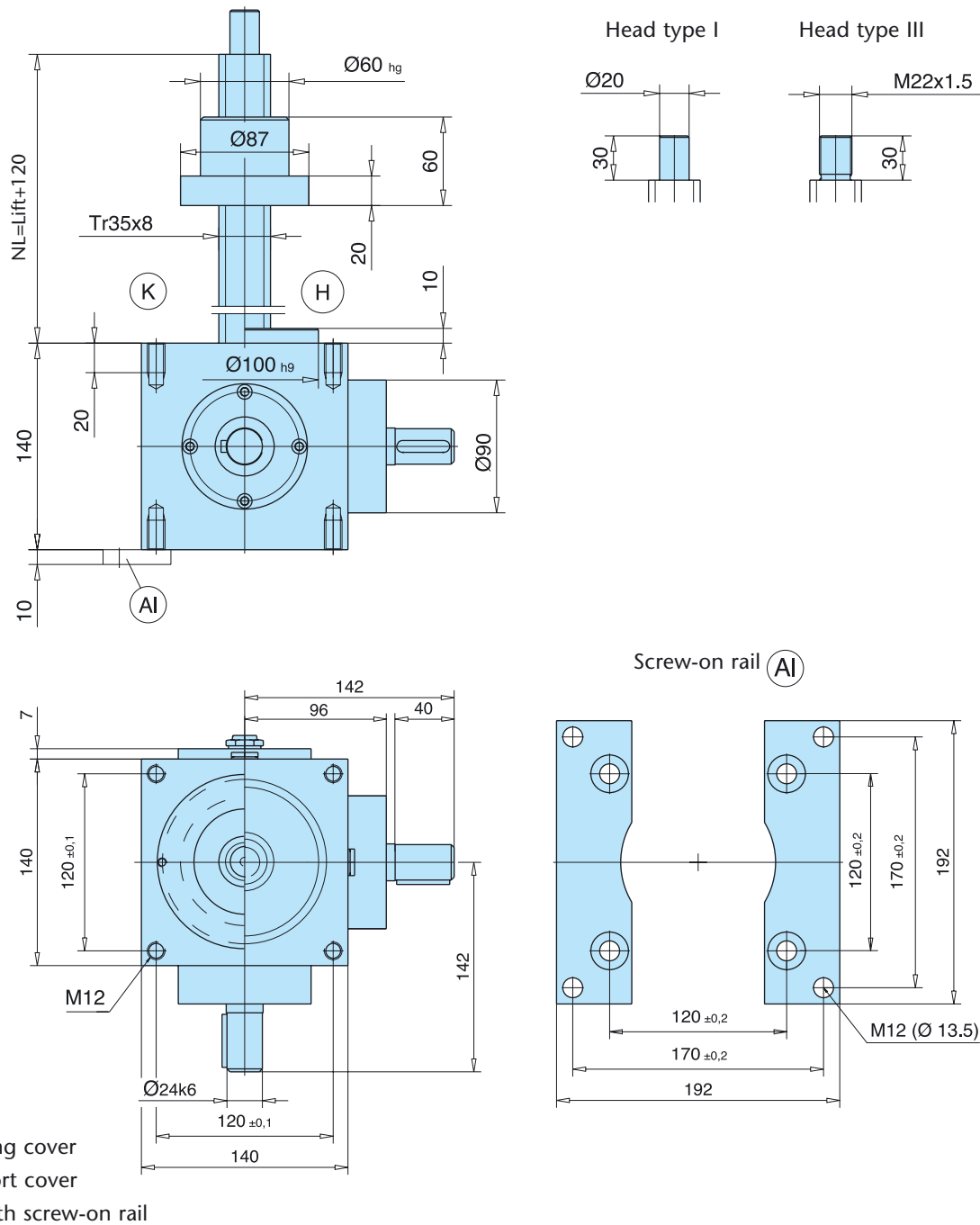

1)



2)



3)

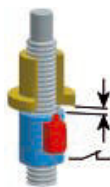

Options:

Dimension plans of the options available on request

- 1) Ball-screw spindle
(flange nut, see section 3.8.2)
- 2) Short safety nut
- 3) Long safety nut

Worm gear screw jacks

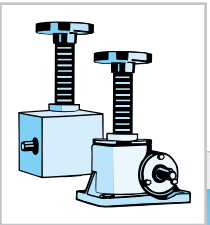

3.7 SHG range dimension plans

3.7.2.4 Size G 90

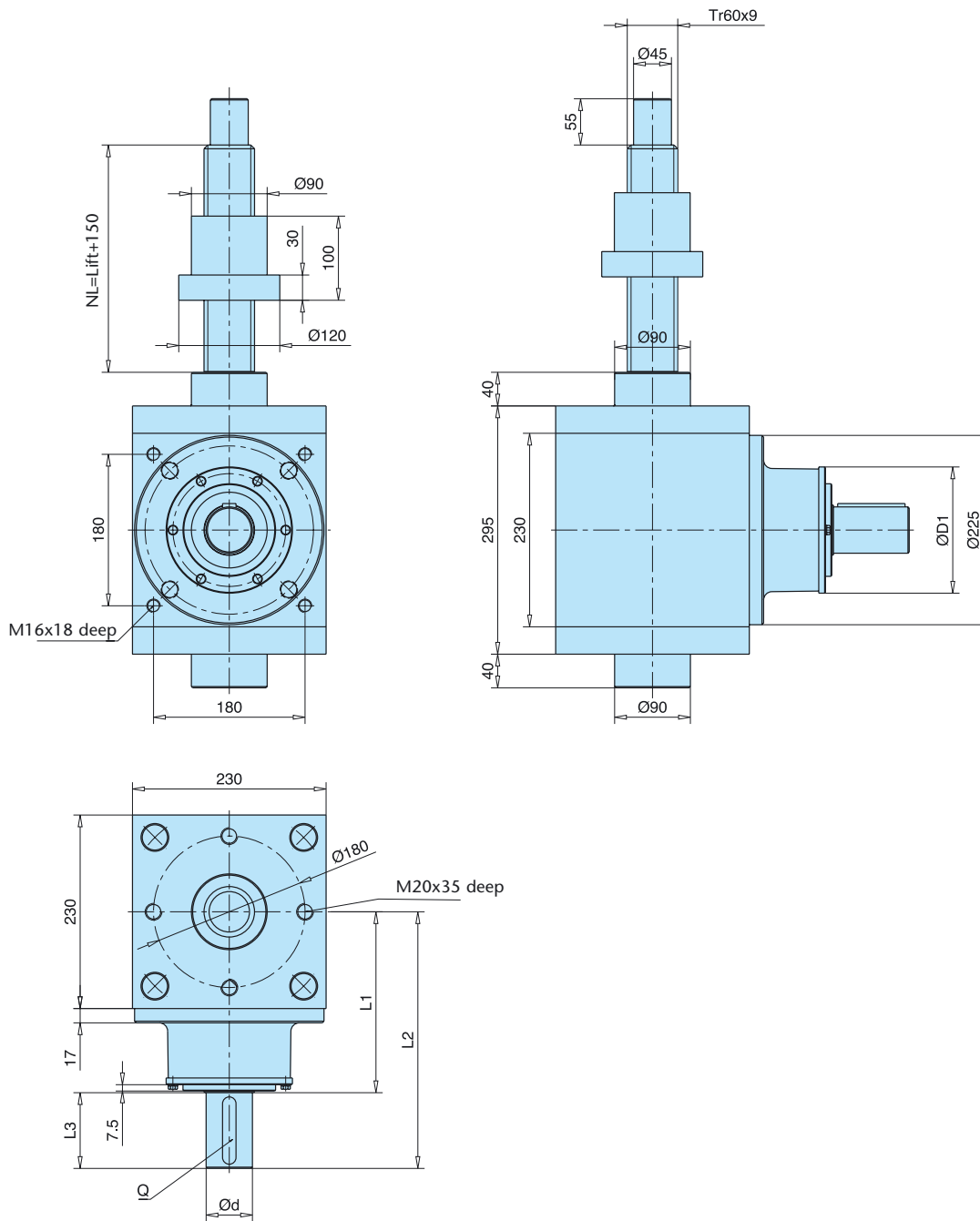

Ratio	Ød j6	ØD1	L1	L2	L3	Q (DIN 6885)
2:1	55	150	215	305	90	A 16x10x80
3:1	40	120	230	310	80	A 12x8x60

Options
Dimension plans of the options available on request

- 1) Ball-screw spindle (flange nut, see section 3.8.2)
- 2) Short safety nut
- 3) Long safety nut

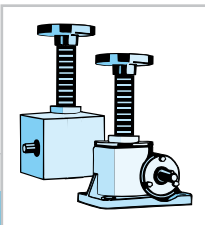

Worm gear screw jacks

3.8 Special travelling nuts dimension plans



3.8.1 LWZ Travelling nut with trunnion

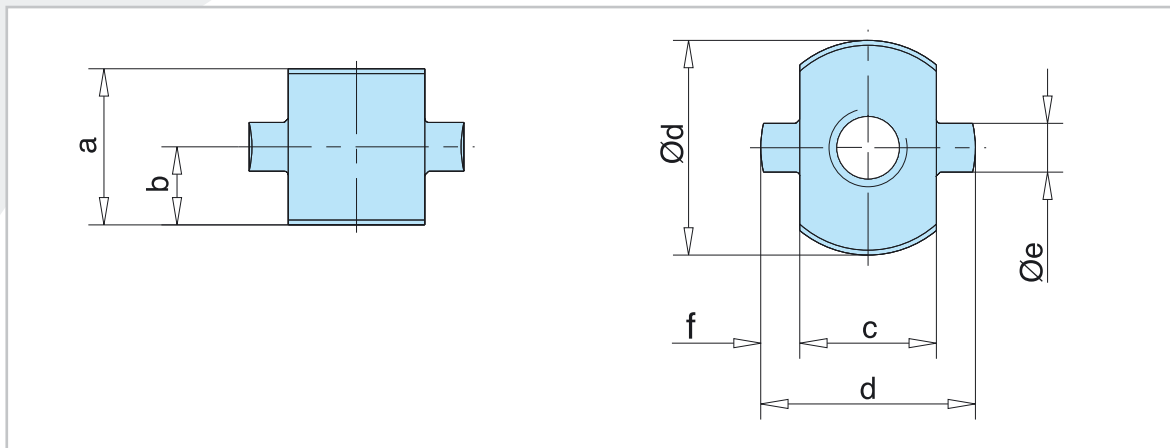

3

3.8.1.1 SHE range

Size	a	b	c	Ød	Øe	f
0,5	45	22,5	35	50	14	7,5
1	50	25	40	60	18	10
2,5	60	30	50	80	25	15
5	70	35	62	95	35	16,5
10/15	120	60	80	130	50	25
20	120	60	92	150	65	29
25	145	72,5	120	190	75	35
35	on request					
50	on request					

3.8.1.2 Merkur range

Size	a	b	c	Ød	Øe	f
M 1	45	22,5	35	50	14	7,5
M 2	50	25	40	60	18	10
M 3	60	30	50	80	25	15
M 4	70	35	62	95	35	16,5
M 5	120	60	80	130	50	25
M 6	120	60	92	150	65	29

3.8.1.3 HSE range

Size	a	b	c	Ød	Øe	f
31	45	22,5	35	50	14	7,5
36	50	25	40	60	18	10
50	60	30	50	80	25	15
63	70	35	62	95	35	16,5
80	120	60	80	130	50	25
100	120	60	92	150	65	29
125	on request					
140	on request					

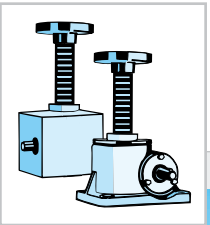

3.8 Special travelling nuts dimension plans

3.8.2 EFM single flange nut for Ku spindle

for all ranges

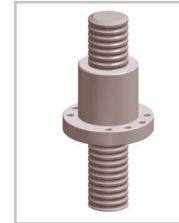
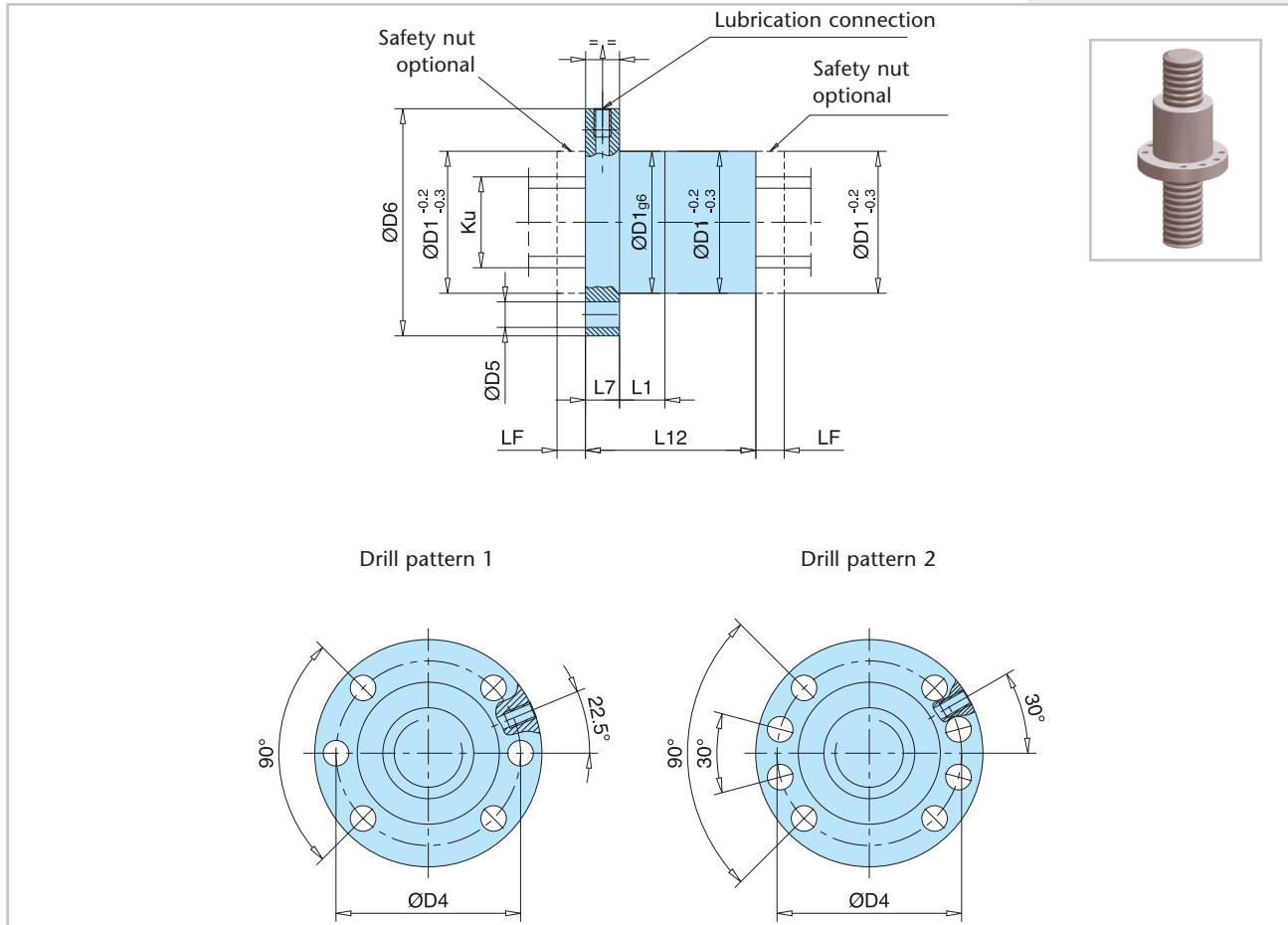

3

Size d0 x P - Dw - i	Load capacities		Nut dimensions										Drill pattern LF
	C _{dyn} [kN]	C _{stat} [kN]	D1	D4	D5	D6	L1	L7	L12	S	Catch nut		
20 x 5RH - 3,5 - 4	22,7	42,6	36	47	6,6	58	10	10	43	M6	1	15	
20 x 10RH - 3,5 - 2	14,0	21,3	36	47	6,6	58	10	10	26	M6	1	20	
25 x 5RH - 3,5 - 4	24,2	54,8	40	51	6,6	62	10	10	43	M6	1	15	
25 x 10RH - 3,5 - 3	19,8	41,1	40	51	6,6	62	16	10	59	M6	1	20	
32 x 5RH - 3,5 - 5	30,8	91,4	50	65	9	80	10	12	50	M6	1	15	
32 x 10RH - 5 - 3	36,6	74,5	50	65	9	80	16	12	40	M6	1	25	
40 x 10RH - 7 - 4	79,2	170,5	63	78	9	93	16	14	76	M8x1	2	30	
40 x 20RH - 7 - 2	48,7	85,3	63	78	9	93	17	14	51	M8x1	2	50	
50 x 10RH - 7 - 6	112,1	328,8	75	93	11	110	16	16	101	M8x1	2	30	
50 x 20RH - 12,7 - 3	158,0	244,8	85	103	11	120	16	16	117	M8x1	2	50	
50 x 24RH - 12,7 - 3	158,0	244,8	85	103	11	120	18	16	92	M8x1	2	55	
63 x 10RH - 7 - 6	122,8	438,2	90	108	11	125	16	18	103	M8x1	2	30	
63 x 20RH - 12,7 - 3	173,5	333,2	95	115	13,5	135	25	20	121	M8x1	2	35	
80 x 10RH - 7 - 6	135,0	584,5	105	125	13,5	145	16	20	105	M8x1	2	30	
80 x 20RH - 12,7 - 5	282,0	800,7	125	145	13,5	165	25	25	170	M8x1	2	50	
100 x 10RH - 7 - 6	146,2	749,9	125	145	13,5	165	16	22	107	M8x1	2	30	
100 x 20RH - 12,7 - 6	336,6	1203,1	150	176	17,5	202	25	30	195	M8x1	2	60	
125 x 10RH - 7 - 6	157,9	952,6	150	170	13,5	190	25	25	110	M8x1	2	40	
125 x 24RH - 12,7 - 6	373,9	1622,2	170	196	17,5	222	25	40	235	M8x1	2	60	
160 x 20RH - 15 - 6	522	2476											

on request

Further Ku nuts on request

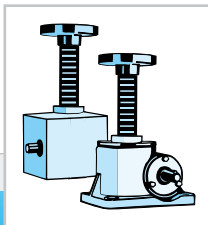

Worm gear screw jacks

3.8 Special travelling nuts dimension plans

3.8.3 LSF Travelling nut with flat surface

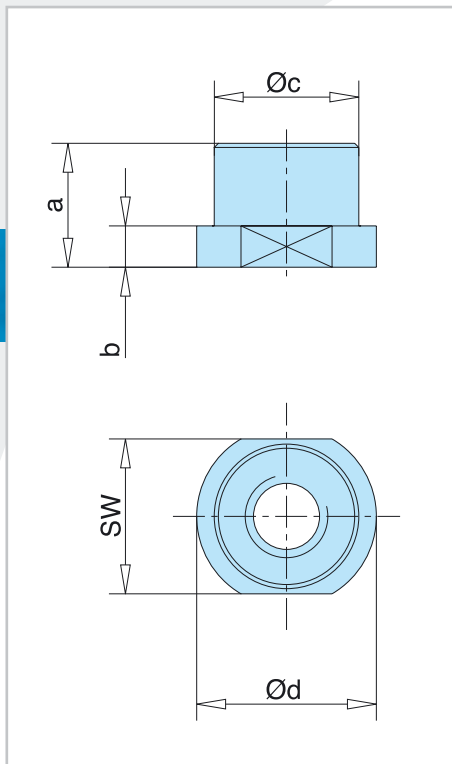
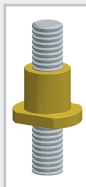

3.8.3.1 SHE / Merkur M range

Size		a	b	Øc	Ød	SW
0,5	M1	32	10	40	50	44
1	M2	40	12	45	65	50
2,5	M3	45	16	50	80	62
5	M4	60	18	70	87	75
10/15	M5	75	25	90	110	95
20	-	100	30	90	120	100
25	M6	120	35	130	155	135
35	M7	145	35	150	190	160
50	M8	155	50	160	225	180

3.8.3.2 HSE range

Size	a	b	Øc	Ød	SW
31	45	12	40	50	44
36	55	15	45	65	50
50	80	18	70	87	75
63	100	22	80	105	85
80	130	30	90	110	95
100	130	30	90	120	100
125	160	45	150	190	160
140	180	50	160	225	180

3.8.4 LSA Travelling nut with spherical support

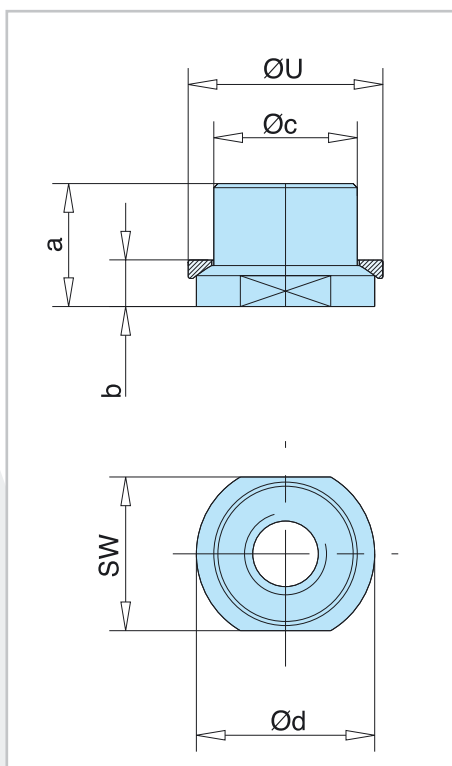
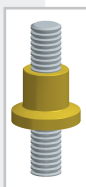

3.8.4.1 SHE range

Size	a	b	Øc	Ød	ØU	SW
0,5	32	10	40	50	55	44
1	40	12	45	65	65	50
2,5	45	16	50	80	82	62
5	60	18	70	87	95	75
10/15	75	25	90	110	120	95
20	100	30	90	120	120	100
25	120	35	130	155	175	135
35	145	35	150	190	195	160
50	155	50	160	225	220	180

3.8.4.2 HSE range

Size	a	b	Øc	Ød	ØU	SW
31	45	12	40	50	55	44
36	55	15	45	65	65	50
50	80	18	70	87	95	75
63	100	22	80	105	110	85
80	130	30	90	110	120	95
100	130	30	90	120	120	100
125	160	45	150	190	195	160
140	180	50	160	225	220	180

More designs available - please request their dimensions!