

JTD

Cubic Ball Screw Jack

Contents

Product Description 001

Sample Part Number 003

Specifications 005

Dimensions 005

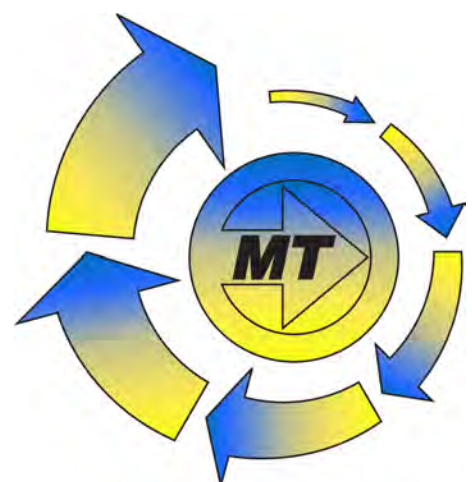

www.motiontech.com.au

2D/3D
CAD



Product Description

JACTON JTD Series Cubic Ball Screw Jack featuring a compact and versatile cubic housing. Cubic Ball Screw Jacks are an excellent solution for industrial lifting, lowering, pushing and/or pulling applications that require higher efficiency, greater accuracy or faster travel speeds than offered by Worm Gear Machine Screw Jacks. The addition of a high efficiency ball screw and nut reduces the required input torque. Required approximately two-thirds less input torque to move the load than similarly rated machine screw jacks. They are NOT self-locking so a brake motor or external locking device needs to be included in the drive system and hand wheels are not a recommended option. Can be mounted in any attitude. Generally maintenance free.

● Features:

- * High accuracy ball screw, high efficiency, high performance, high duty cycle, low backlash, long service life, and uniform lifting speed
- * Available in 7 sizes from JTD10 to JTD300.
- * Maximum load capacity from 10 kN to 150 kN.
- * Ball screw diameter from 20 mm to 100 mm.
- * Standard ball screw maximum length 6000 mm, custom longer stroke.
- * Upright or Inverted mounting. Available in tension or compression loads.
- * Translating, Ant-rotation, and Rotating designs.
- * Each model has TWO gear ratios (High ratio, Slow ratio).
- * Standard with 1-start ball screw, custom 2-starts ball screw which offers increased travel speed. Both of them require a brake or external locking device to hold position.
- * Custom-made machine screw diameter and pitch, gear ratios, and worm shaft sizes.
- * Ball Screw Ends: top plate, clevis end, plain end, threaded end, fork end, rod end.
- * Can be operated by manually operated or by electrical motor driven.
- * Single unit use, or complete jacking system including gear motors, bevel gearboxes, connecting shafts

Product Description

and couplings for dual or multiple jack arrangements.

- * Custom-made double clevis screw jacks, anti-backlash screw jacks.
- * Can be used as alternatives to hydraulic and pneumatic systems.

● **Materials:**

- * Ball Screw: SCM 450, S55C, Hardness: HRC 58-62
- * Ball Nut: SCM415H, Hardness: HRC 58-62
- * Steel Ball: SUJ2, Hardness: HRC 60 UP
- * Worm(Input Shaft): Hardened worm, carbon steel #45. Custom stainless steel.
- * Worm Gear(Wheel): High strength bronze.
- * Travelling Nut: High strength bronze.
- * Housing(Gearbox): Ductile Iron or Stainless steel, available in both of them.

● **Accessories:**

- * Motorized driven (AC or DC) by asynchronous motors (normal, YEJ brake, YVP variable frequency, B explosion proof, D multi-speed), stepper motors, servo motors with encoders and controllers. IEC motor flange or NEMA C-Face motor adapter for connect with motors. Frequency inverters.
- * Manually operated by Aluminum handwheels, or Cast iron handwheels.
- * Connection Devices: Couplings. Universal joints. Telescopic universal joints. Connecting shafts.
- * Screw Protective Devices: Bellows boot. Telescopic spring covers. Protective tubes.
- * Safety Devices: Limit switches. Proximity switches. Safety nuts. Anti-backlash nut. Overload safety couplings. Stop nuts. Position Encoders. Overload clutch. Brake motor. Linear braking elements. Wear detection/monitors. Linear guides and rails. Potentiometer. Pressure sensor.
- * Others Accessories: Travel nuts. Position indicators. Trunnion adapter plates. Trunnion mounting brackets. Pillow blocks. Flange blocks. Rod end bearings.

Sample Part Number

Sample Parts Numbers: JTD50 - US - 300 - H - I - C - PP
 (1) (2) (3) (4) (5) (6) (7)

(1) Models & (4) Ratios

JTD10 (Ball Screw 20 x 5) H: 1/5, L: 1/20	JTD20 (Ball Screw 32 x 5) H: 1/6, L: 1/24	JTD50 (Ball Screw 40 x 10) H: 1/7, L: 1/28	JTD80 (Ball Screw 50 x 10) H: 1/9, L: 1/36	JTD100 (Ball Screw 63 x 10) H: 1/10, L: 1/40
JTD200 (Ball Screw 80 x 10) H: 1/10, L: 1/40	JTD300 (Ball Screw 100 x 20) H: 1/10, L: 1/40	H: High Gear Ratio, L: Slow Gear Ratio		

(2) Jack Design and Configuration

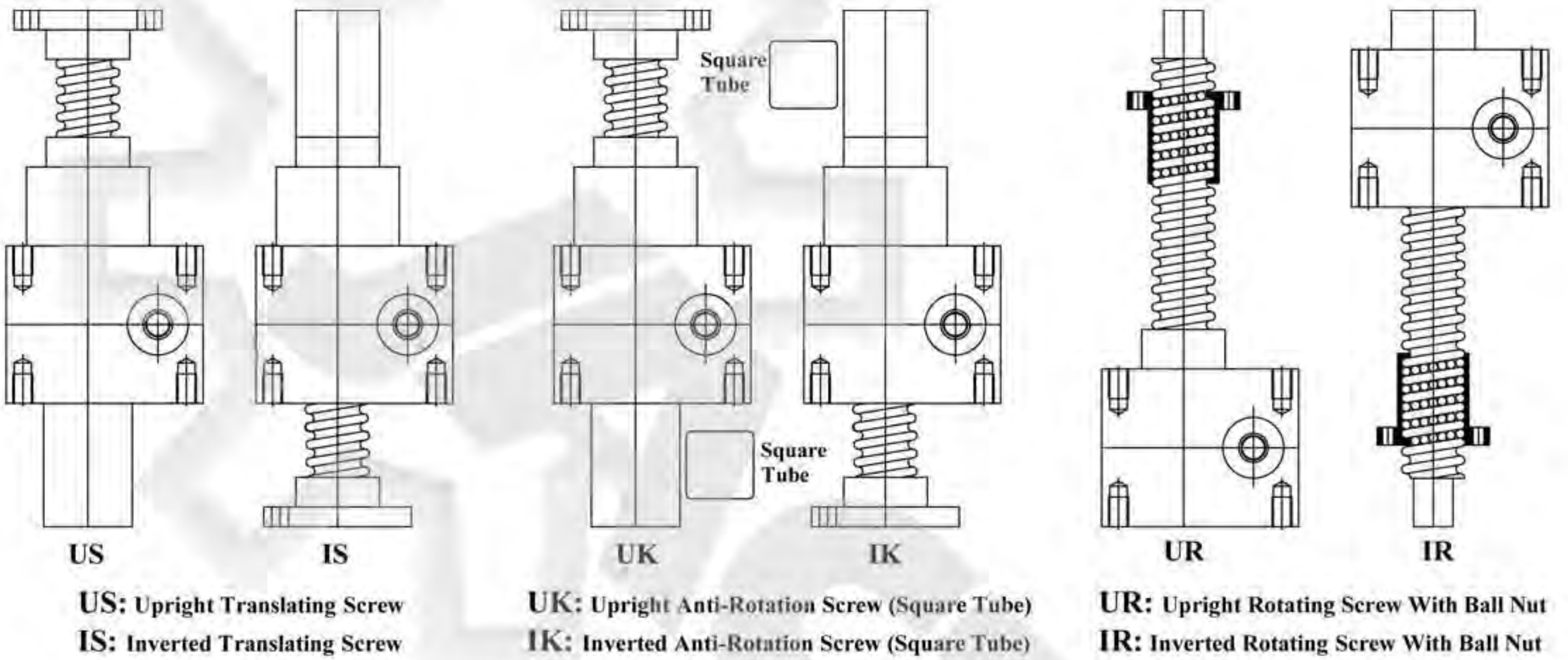

(3) Stroke & (5) Screw End Fittings

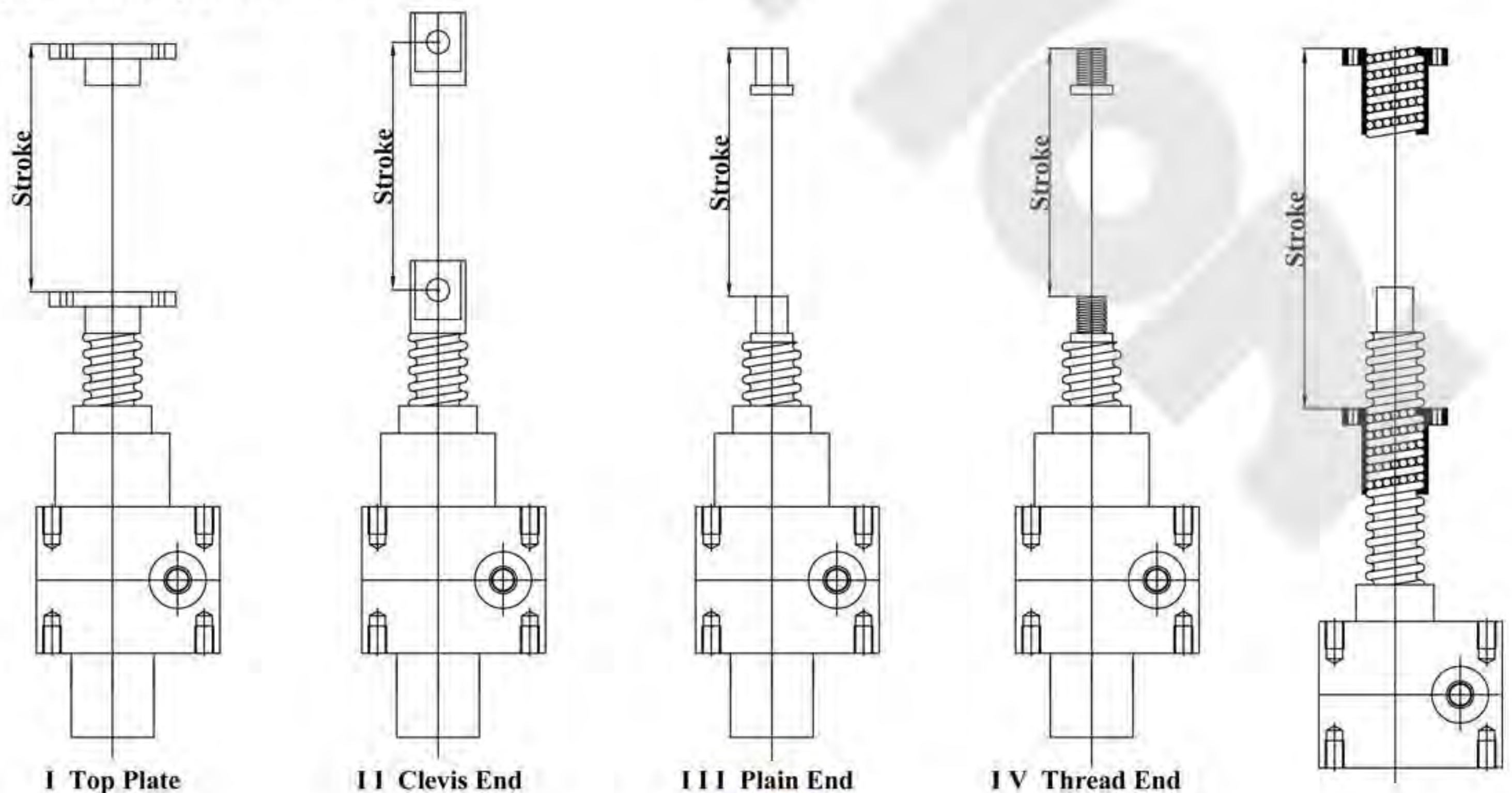

Sample Part Number

(6) Input Shafts Types & Motor Flange Types

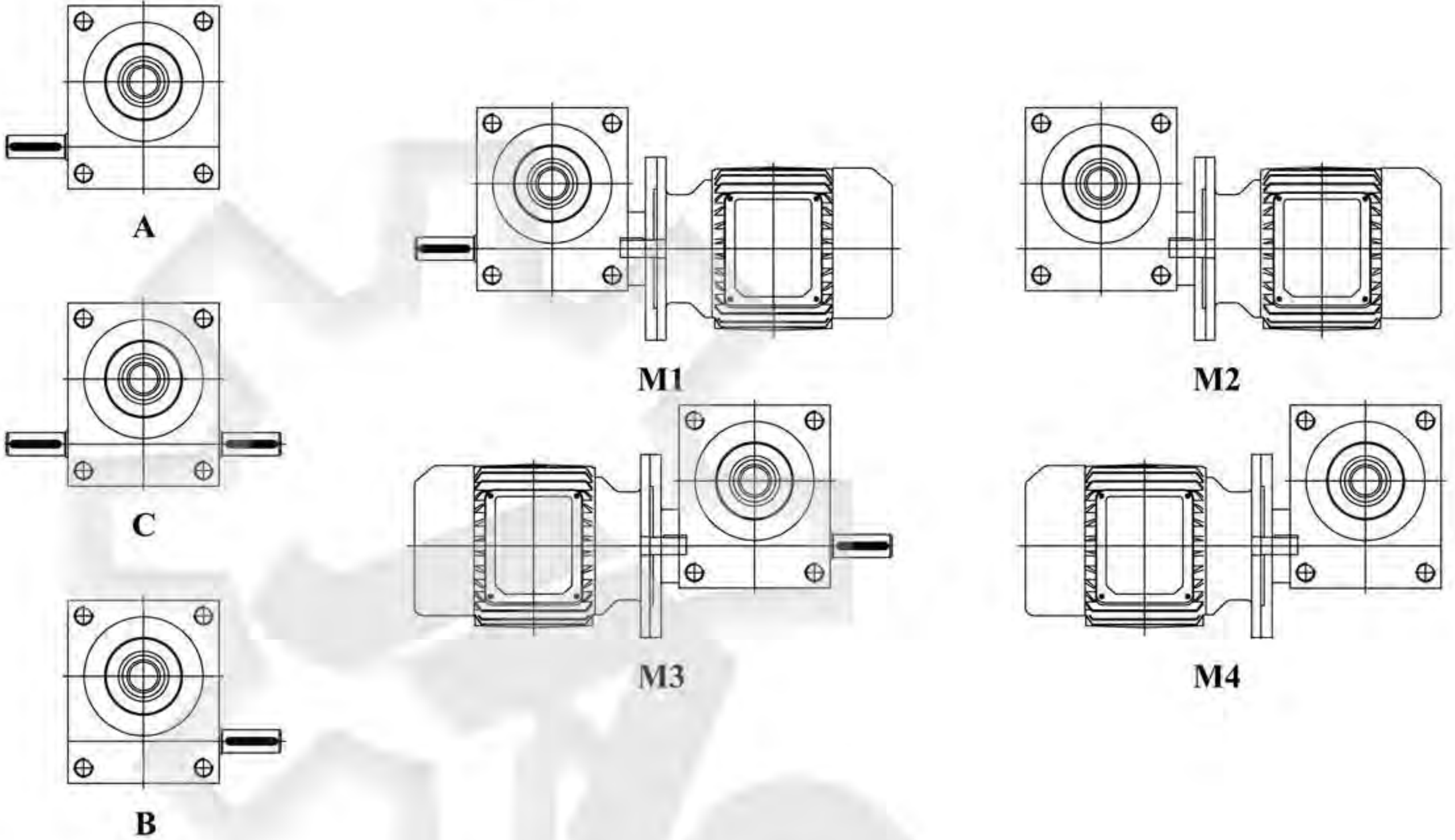

(7) Accessories

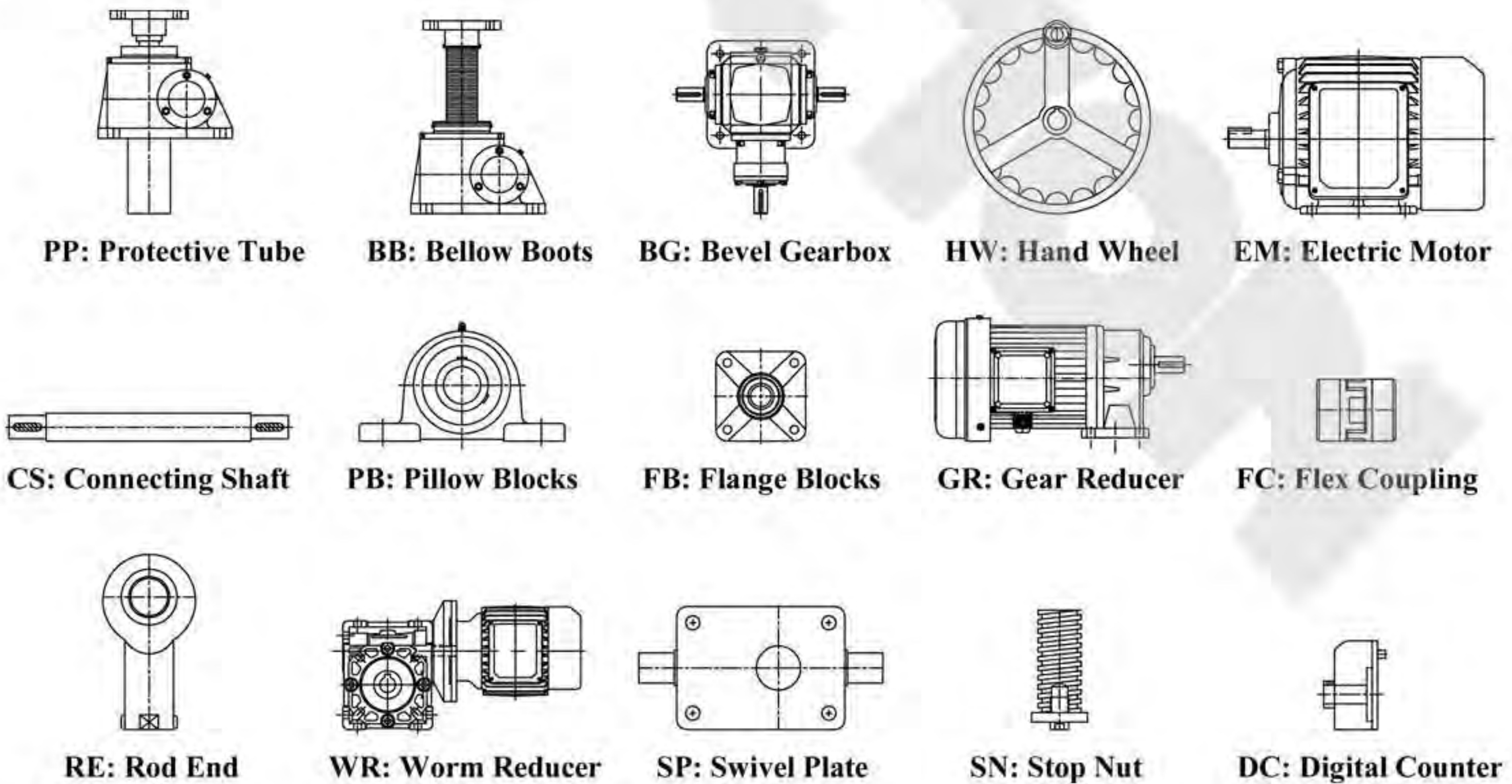

Specifications

Remarks:

- 1) H: high ratio, L: slow ratio
- 2) Max. allowable power is under the conditions that ambient temperature 20 degree C, duty cycle 20%h and input speed 1500rpm.
- 3) Overall efficiency is under grease lubrication.
- 4) Without self-locking, locking mechanisms or brake motors are required.

Model	JTD10	JTD25	JTD50	JTD80	JTD100	JTD200	JTD300
Maximum load capacity (kN)	10	20	50	60	80	90	150
Rated dynamic load (kN)	10	17	46	53	71	78	111
Ball screw Diameter x Lead (mm)	20 x 5	32 x 5	40 x 10	50 x 10	63 x 10	80 x 10	100 x 20
Gear ratio	H: 5:1 L: 20:1	H: 6:1 L: 24:1	H: 7:1 L: 28:1	H: 9:1 L: 36:1	H: 10:1 L: 40:1	H: 10:1 L: 40:1	H: 10:1 L: 40:1
Lift screw travel (mm), per turn of input shaft	H: 1.00 L: 0.25	H: 0.83 L: 0.21	H: 1.43 L: 0.36	H: 1.11 L: 0.28	H: 1.00 L: 0.25	H: 1.00 L: 0.25	H: 2.00 L: 0.50
Start-Up Efficiency %	H: 41 L: 27	H: 32 L: 20	H: 33 L: 20	H: 32 L: 20	H: 32 L: 20	H: 31 L: 18	H: 30 L: 18
Overall Efficiency % Under 1500RPM	H: 54 L: 37	H: 53 L: 34	H: 54 L: 34	H: 53 L: 34	H: 53 L: 34	H: 50 L: 30	H: 48 L: 30
Maximum permissible input power (kW)	H: 0.57 L: 0.27	H: 1.14 L: 0.55	H: 2.2 L: 1.1	H: 2.5 L: 1.5	H: 3.0 L: 2.2	H: 4.0 L: 3.5	H: 7.0 L: 5.5
Gear housing material	Aluminum / Ductile Iron			Ductile Iron			
Weight without stroke (kg)	3.5 6.5	5.0 9.5	23	38	62	78	125
Weight of screw (kg), per 100 mm stroke	0.5	0.8	1.6	2.5	3.2	4.6	7.3

Dimensions

JTD 10

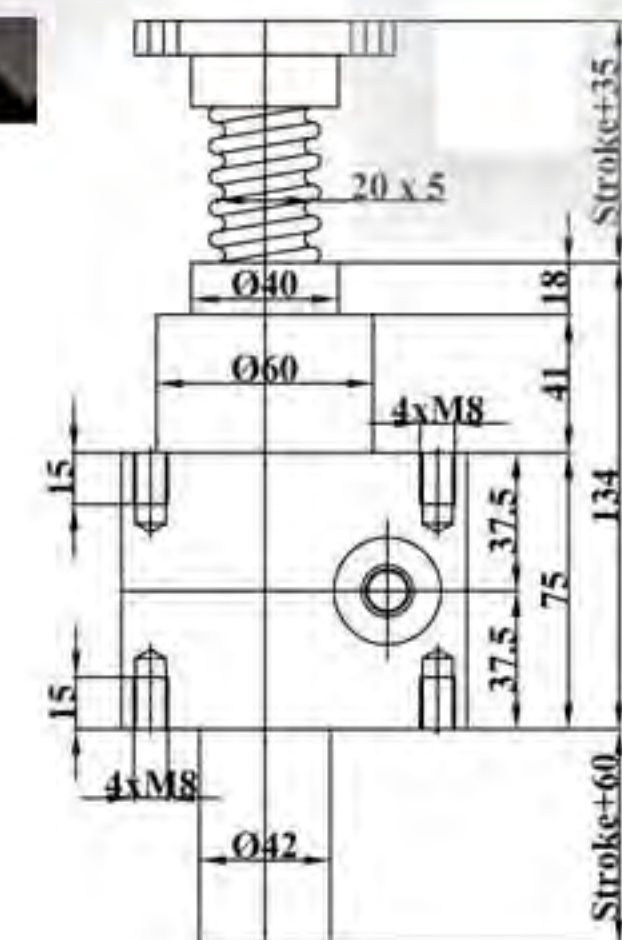

Upright

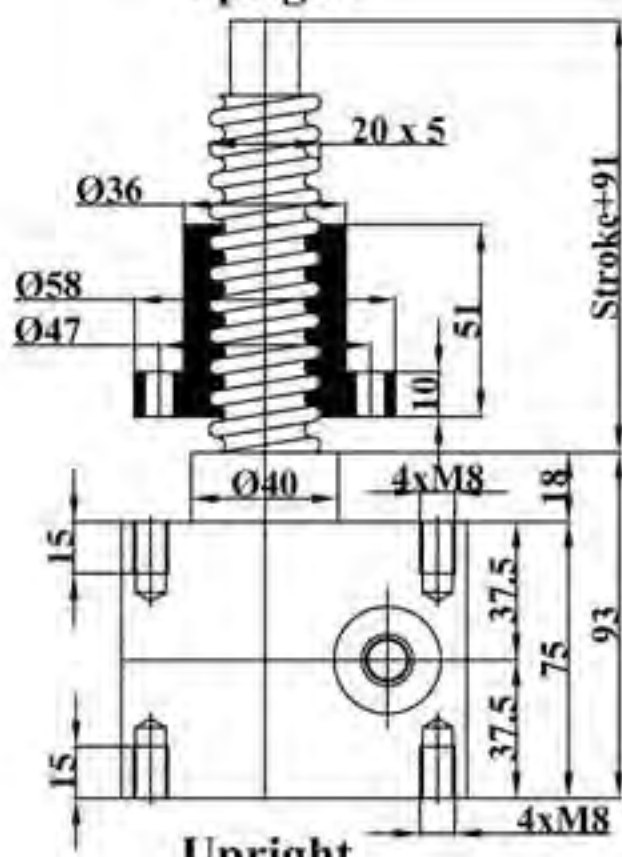

Upright

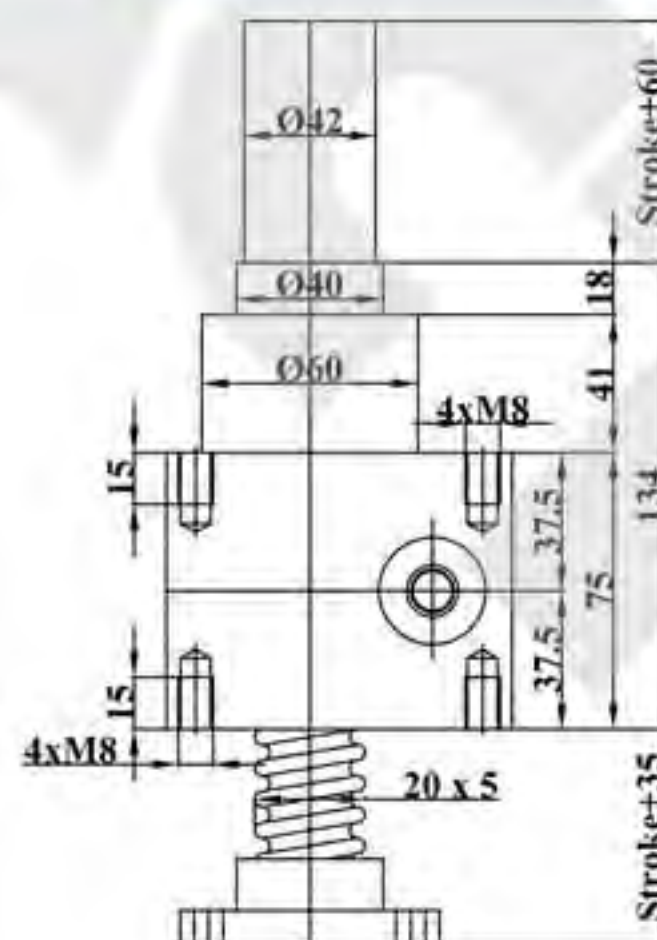

Inverted

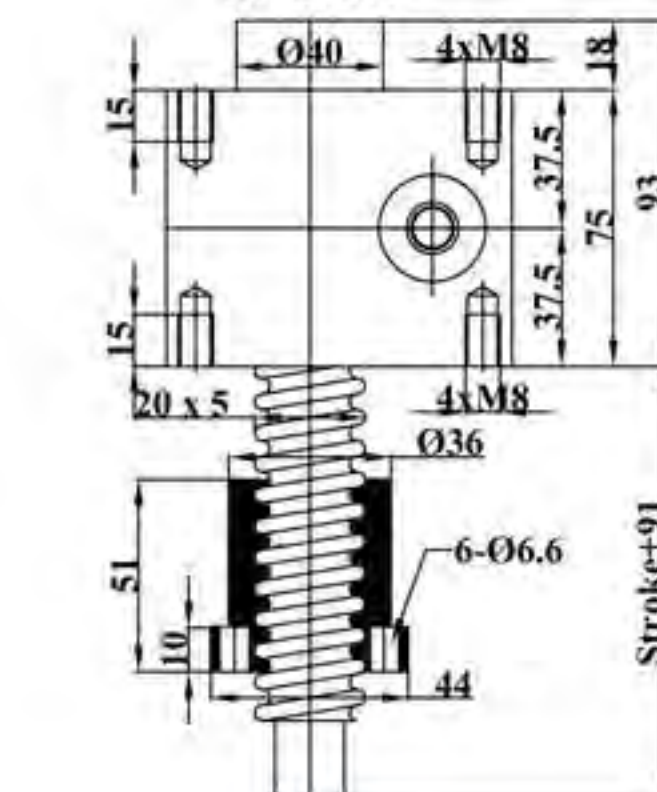

Inverted

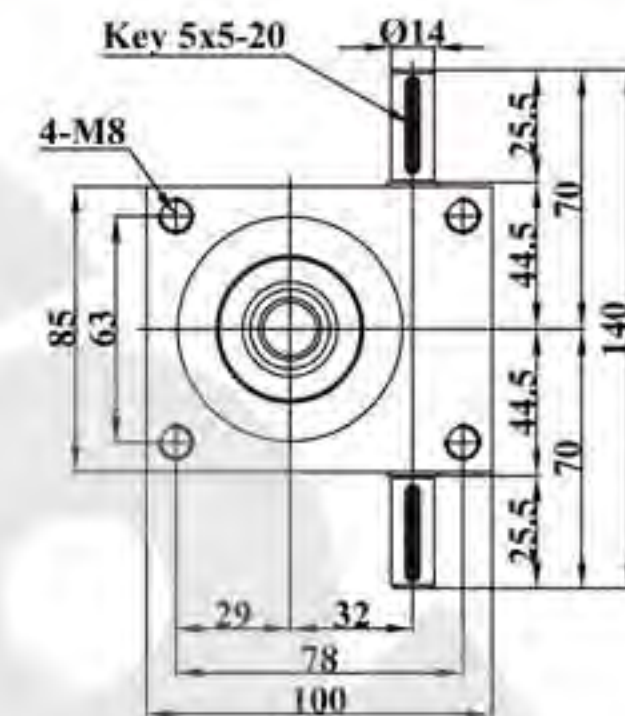

Screw End Types and Dimensions

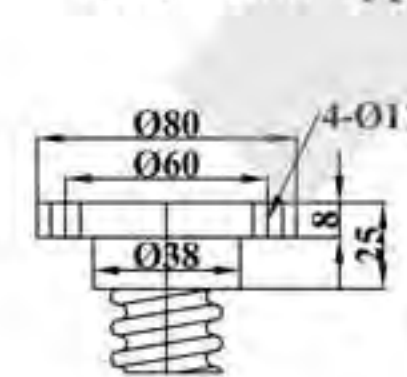

I Top Plate

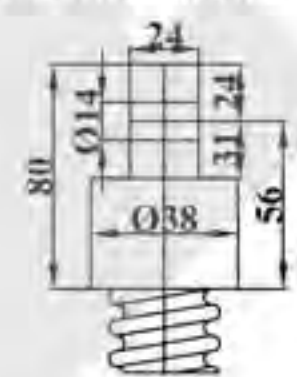

II Clevis End

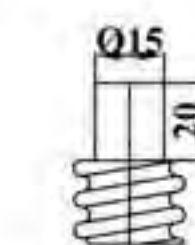

III Plain End

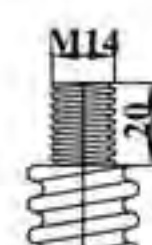

IV Thread End



*. Dimensions are subject to change without notice

Dimensions

JTD 25

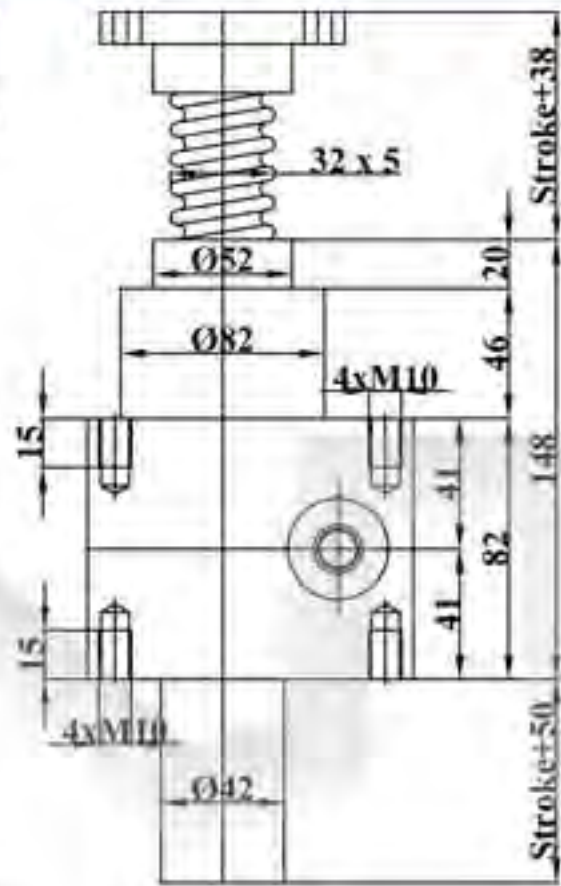

Upright

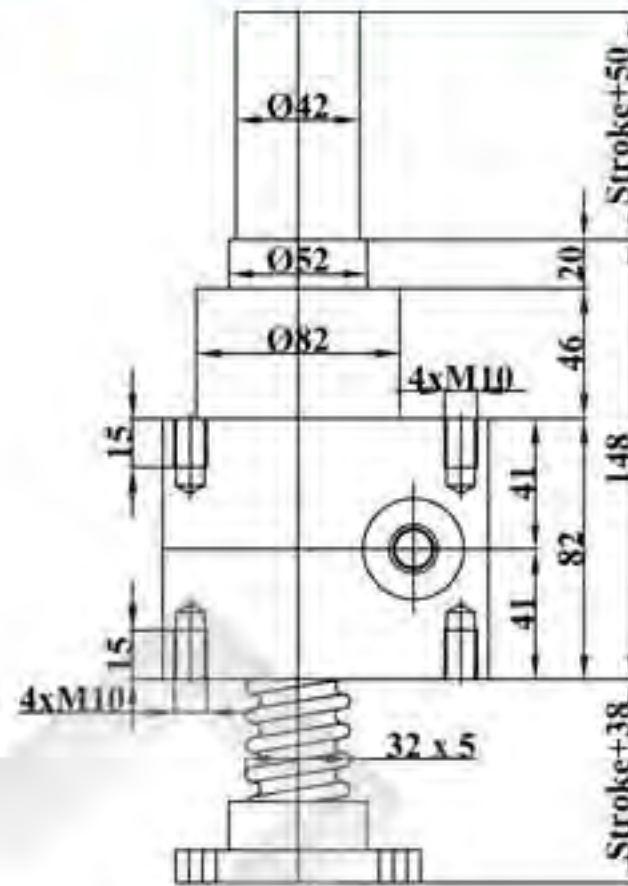

Inverted

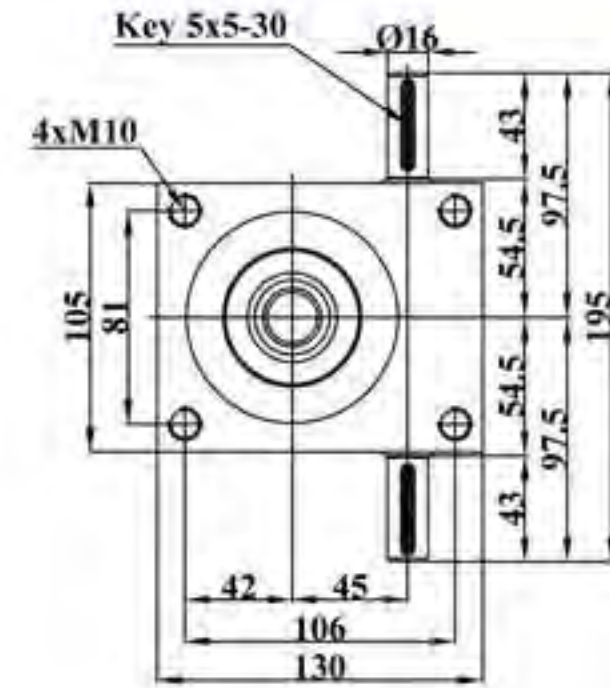

Screw End Types and Dimensions

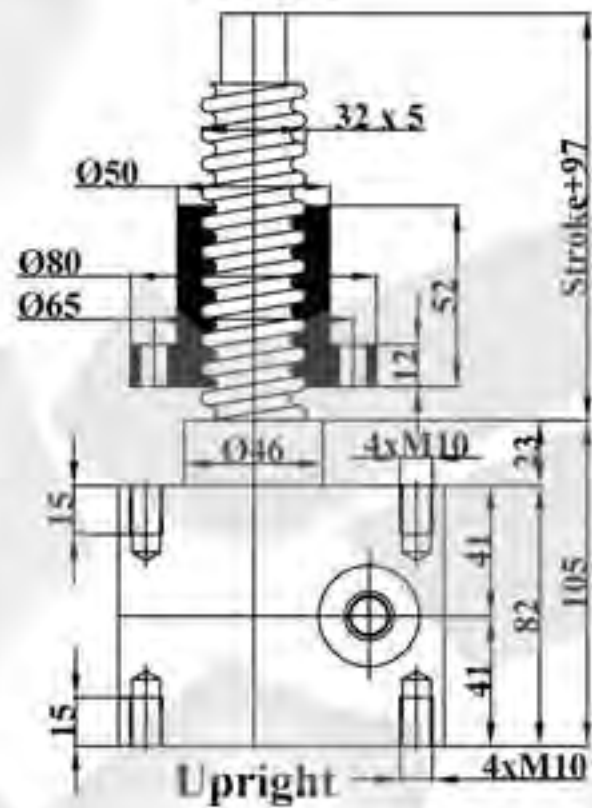

Upright

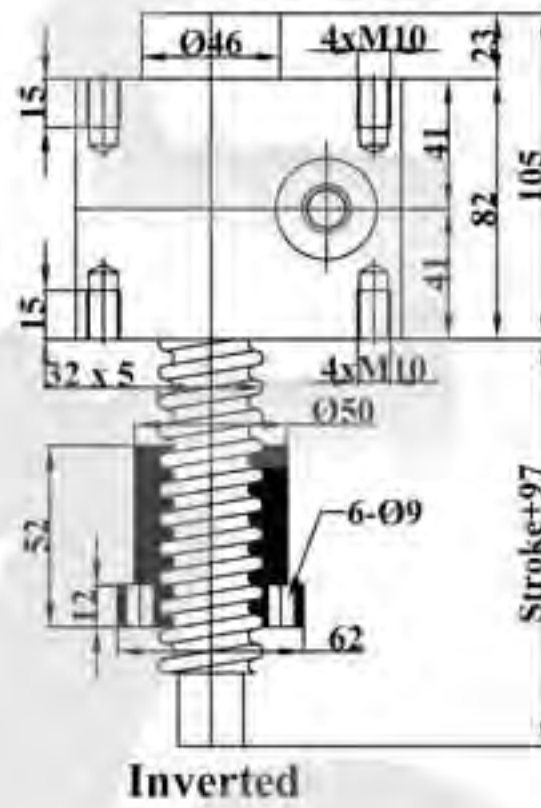

Inverted

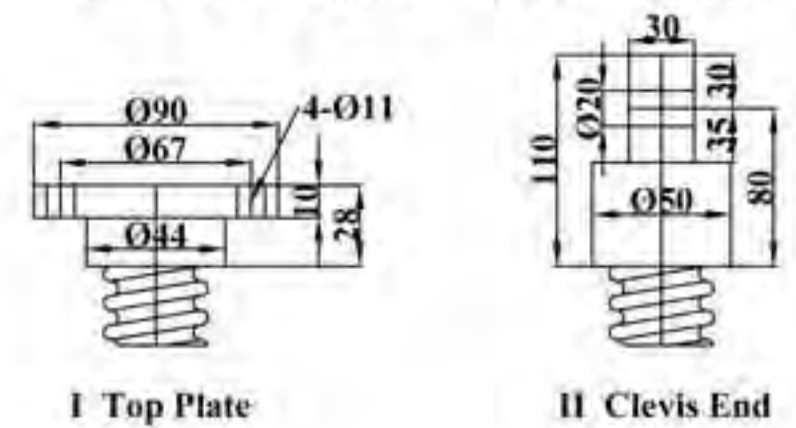

I Top Plate

II Clevis End

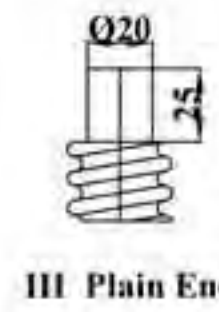

III Plain End

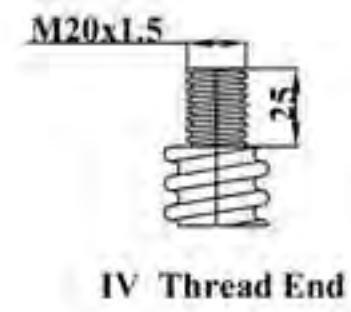

IV Thread End

JTD 50

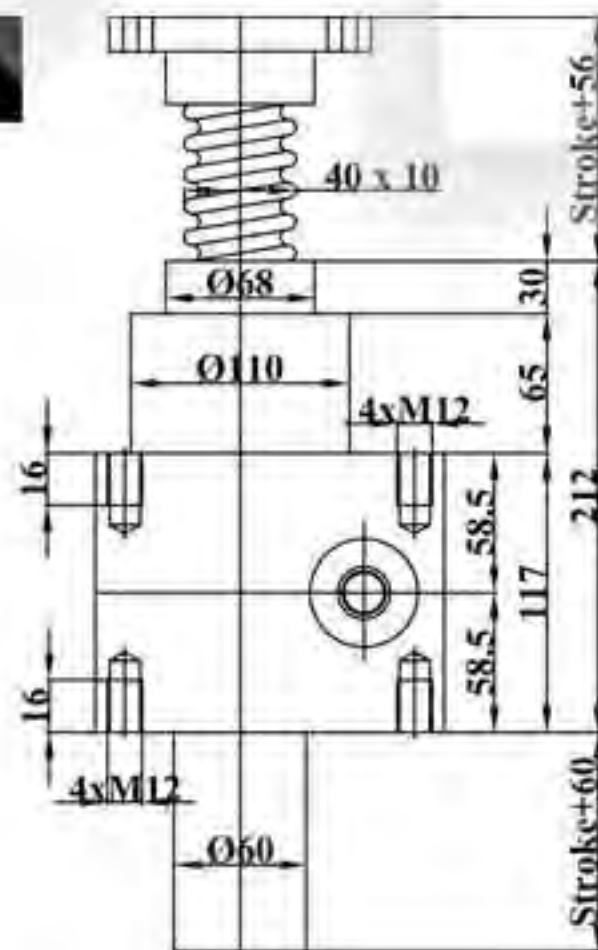

Upright

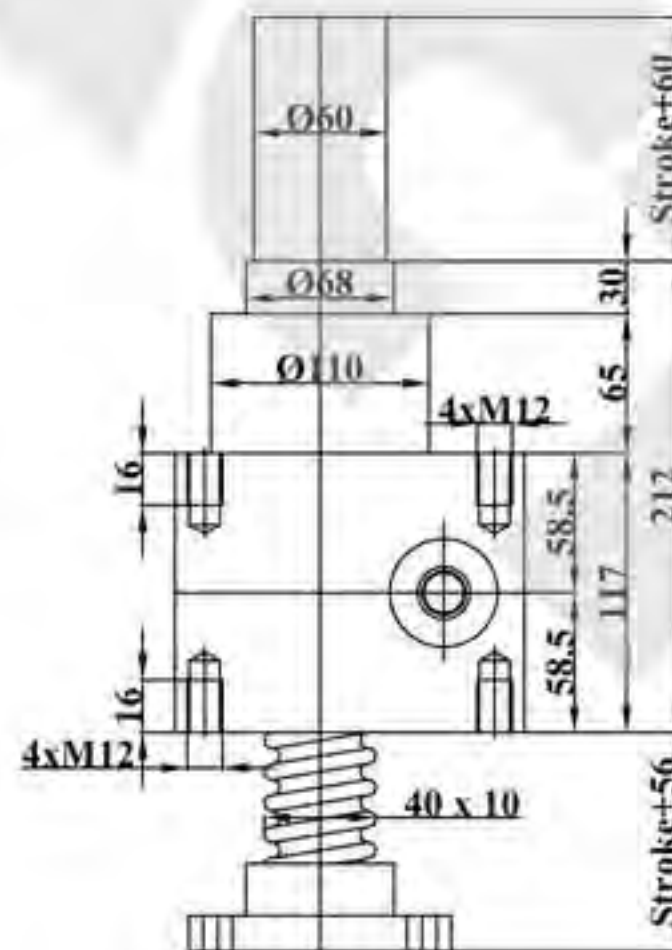

Inverted

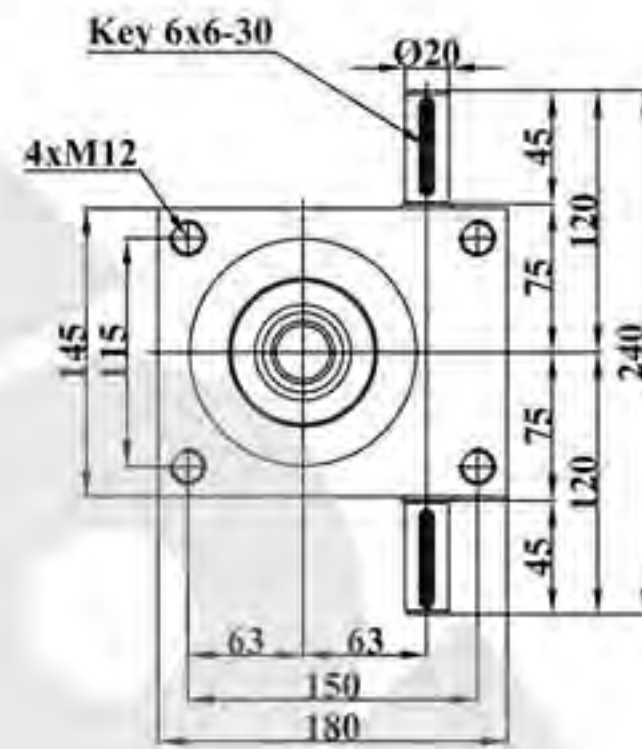

Screw End Types and Dimensions

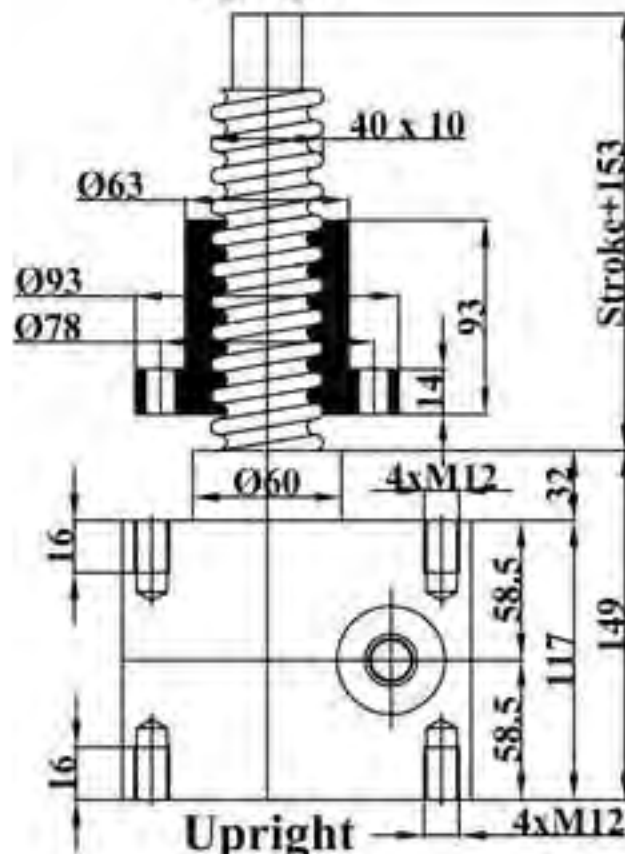

Upright

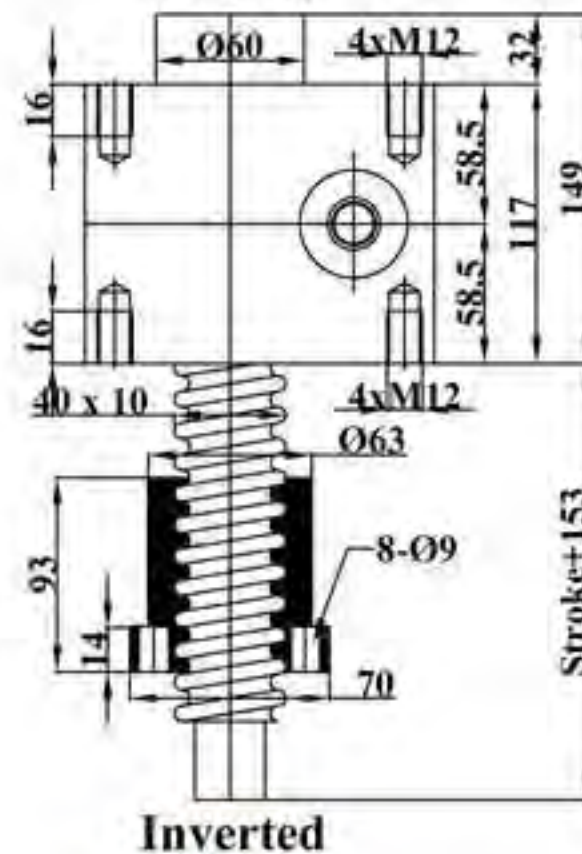

Inverted

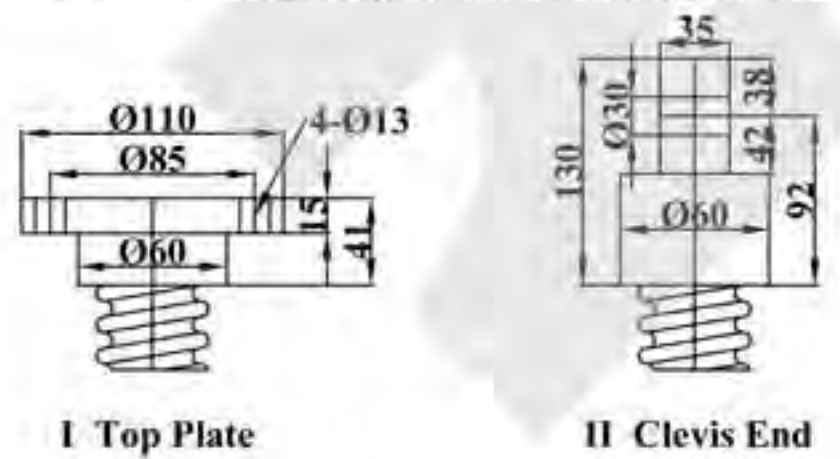

I Top Plate

II Clevis End

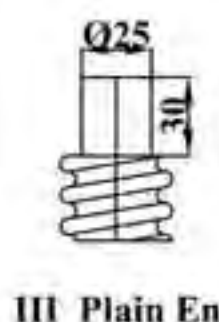

III Plain End

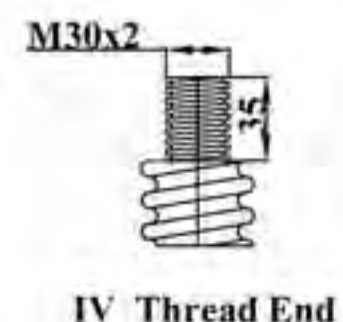

IV Thread End



*. Dimensions are subject to change without notice

Dimensions

JTD 80

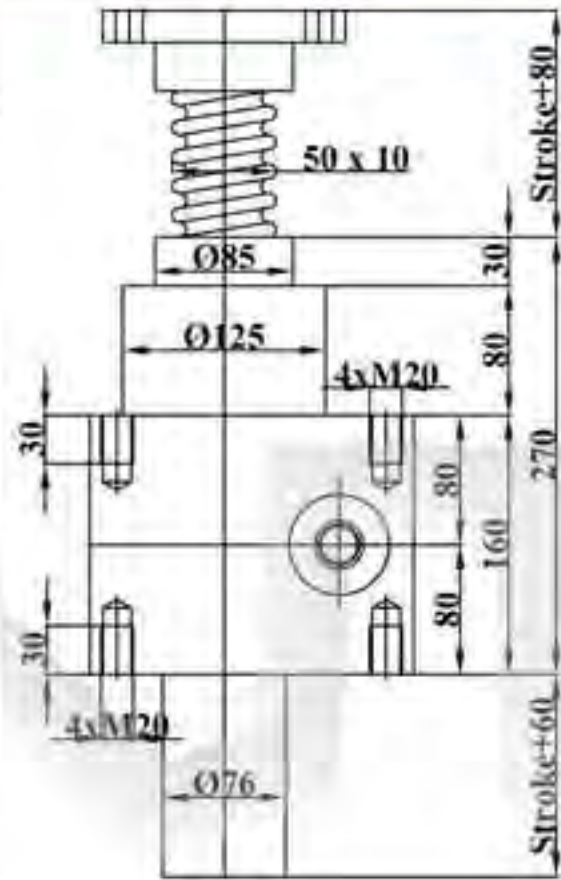

Upright

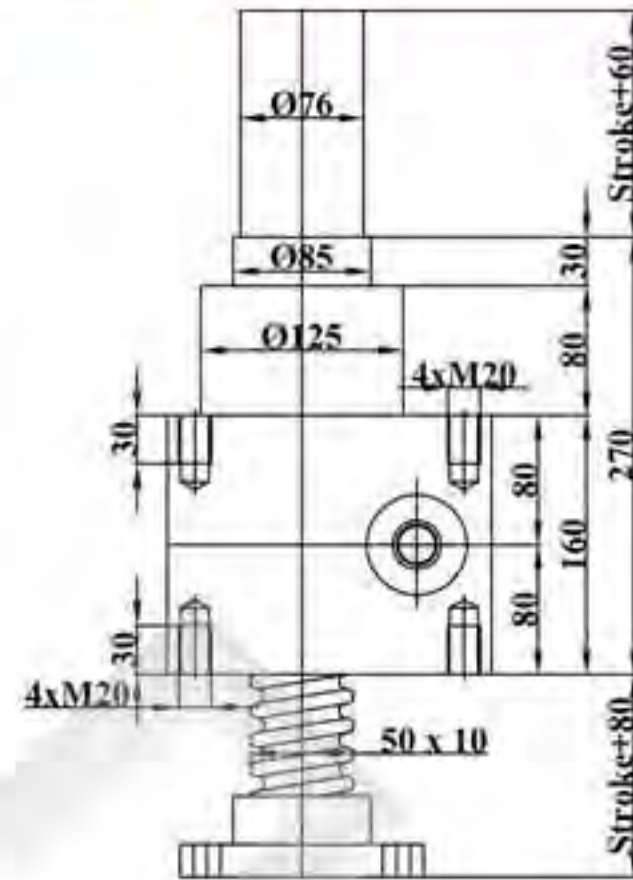

Inverted

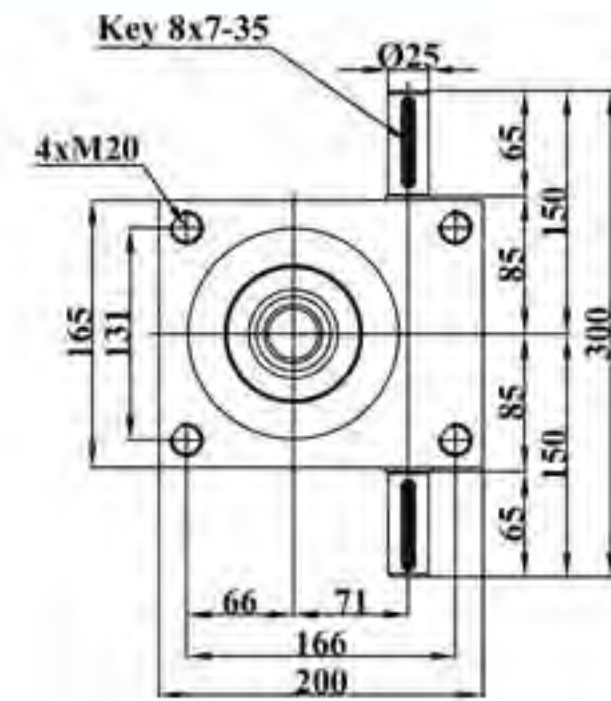

Screw End Types and Dimensions

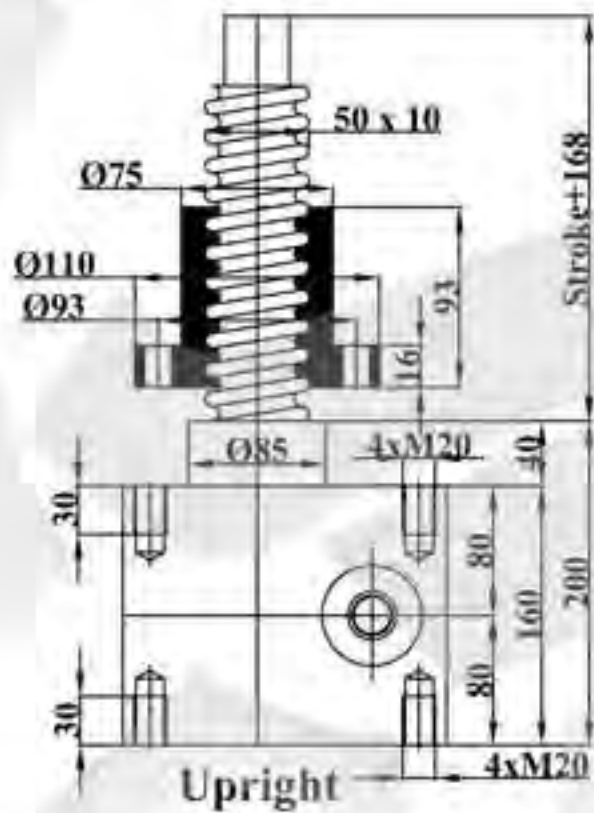

Upright

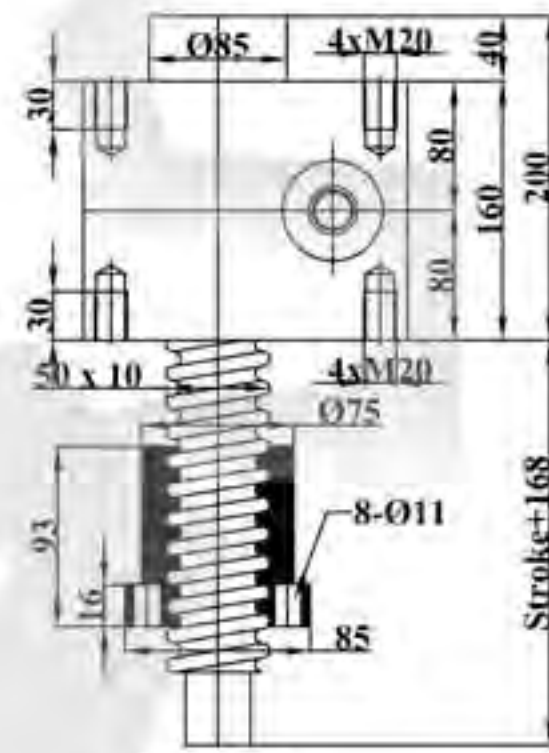

Inverted

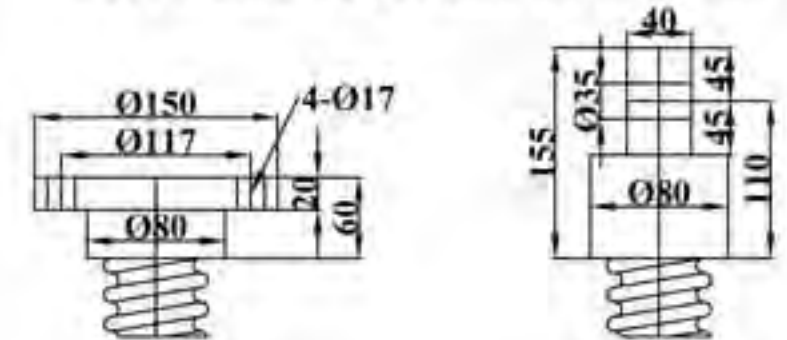

I Top Plate

II Clevis End

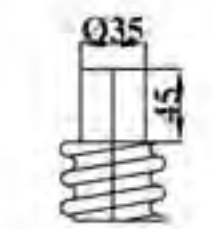

III Plain End

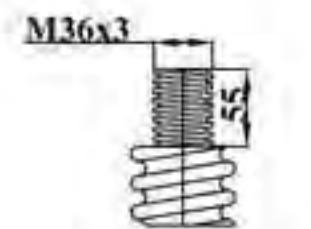

IV Thread End

JTD 100

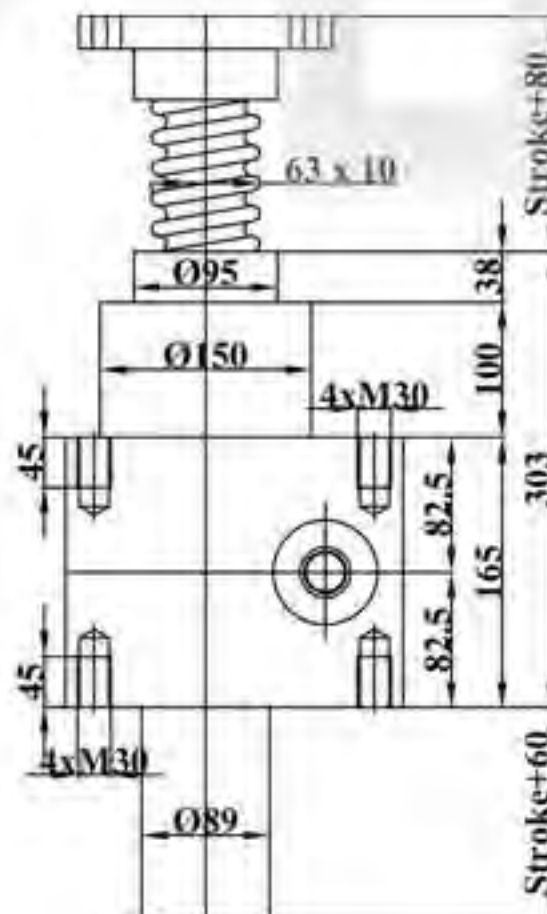

Upright

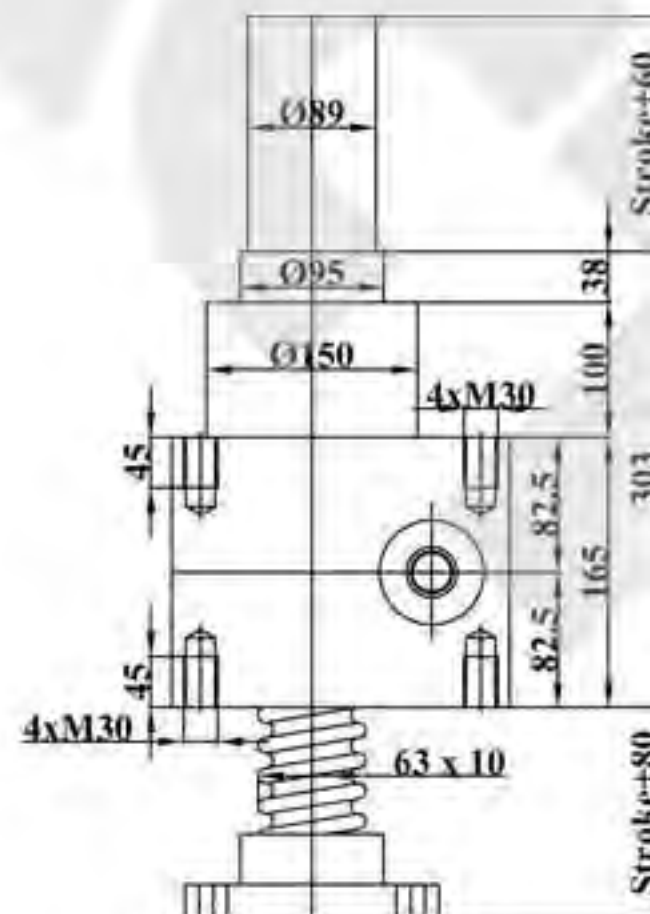

Inverted

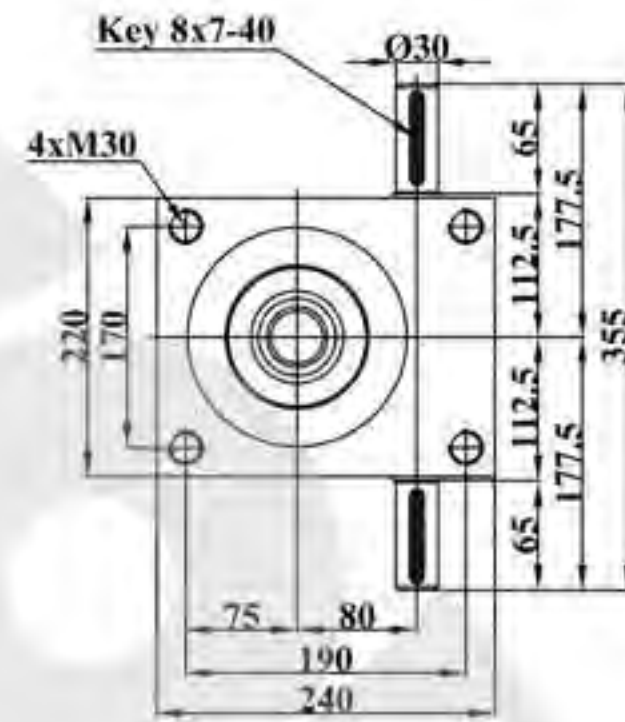

Screw End Types and Dimensions

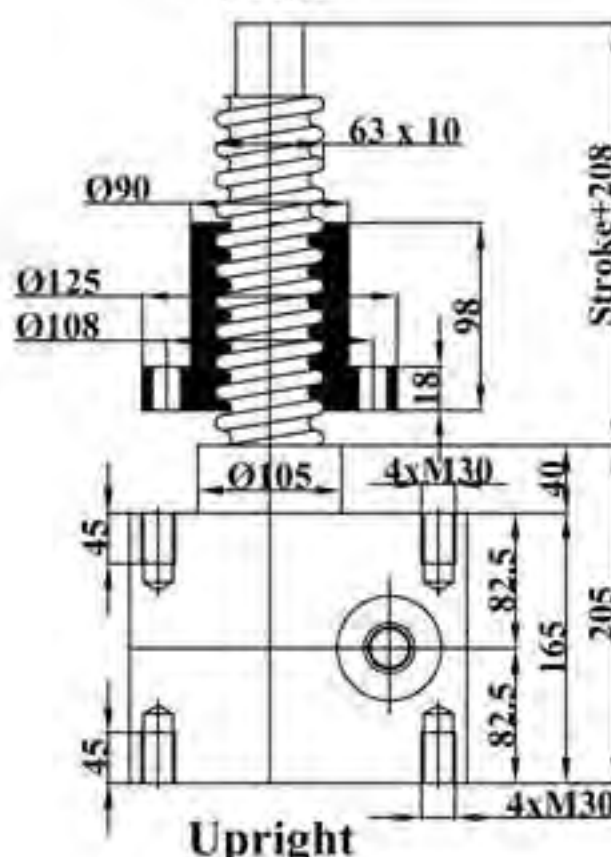

Upright

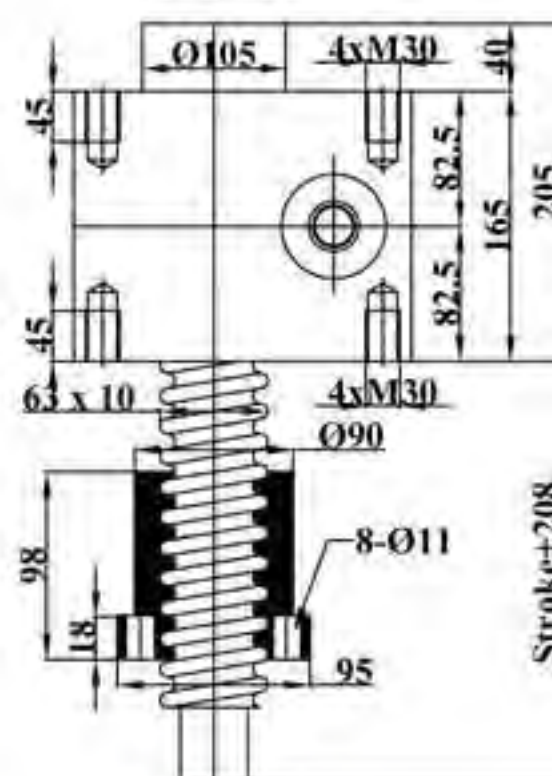

Inverted

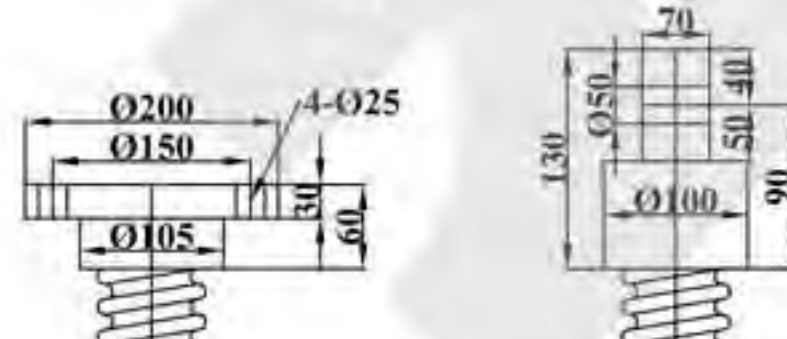

I Top Plate

II Clevis End

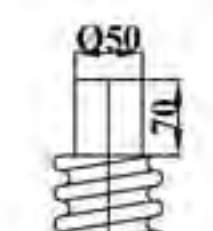

III Plain End

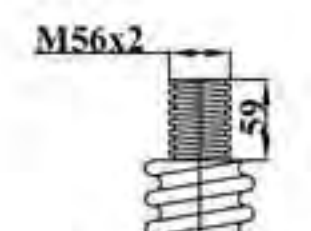

IV Thread End

Dimensions

JTD 200

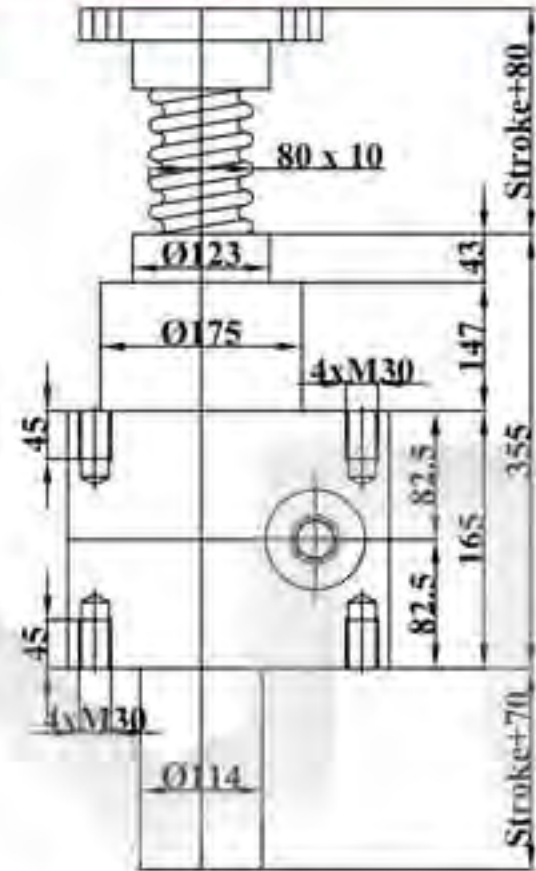

Upright

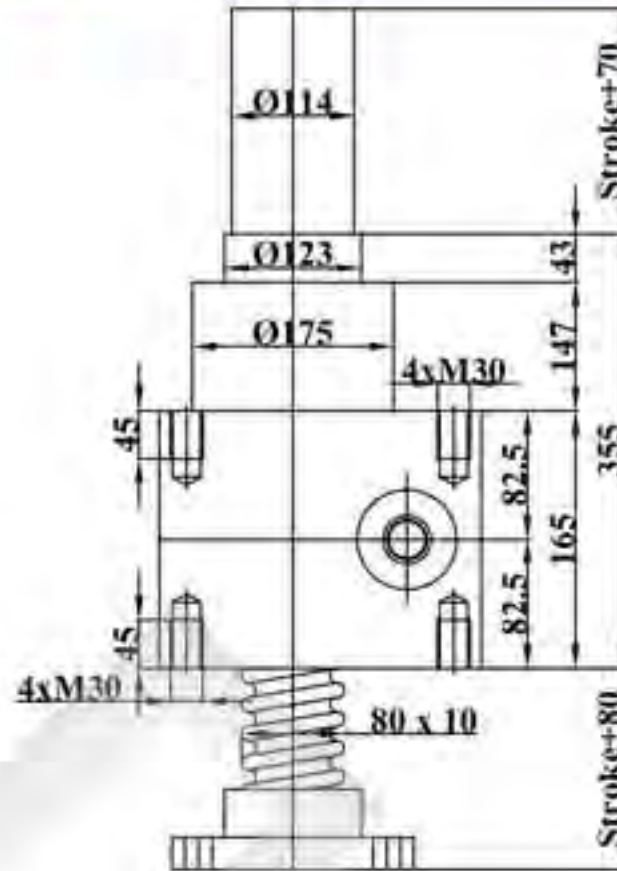

Inverted

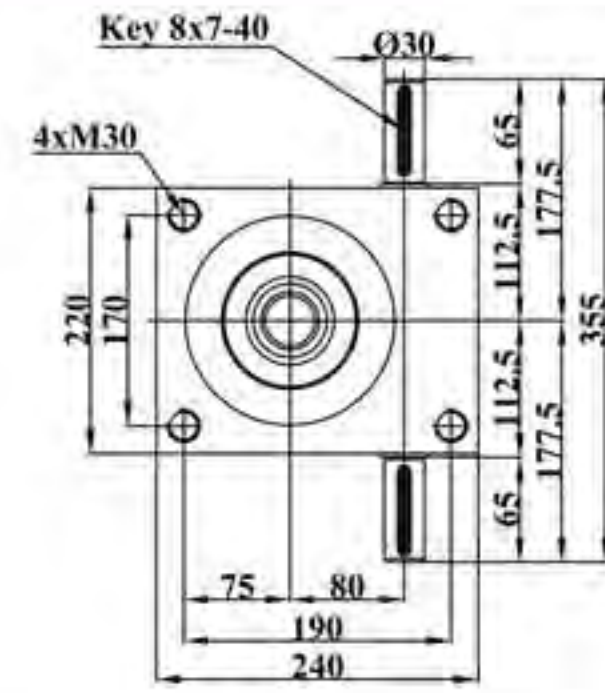

Screw End Types and Dimensions

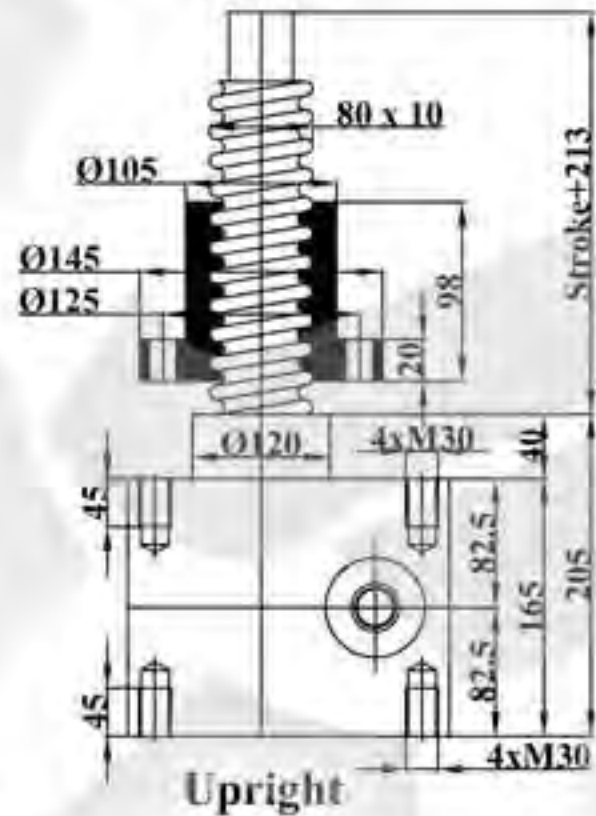

Upright

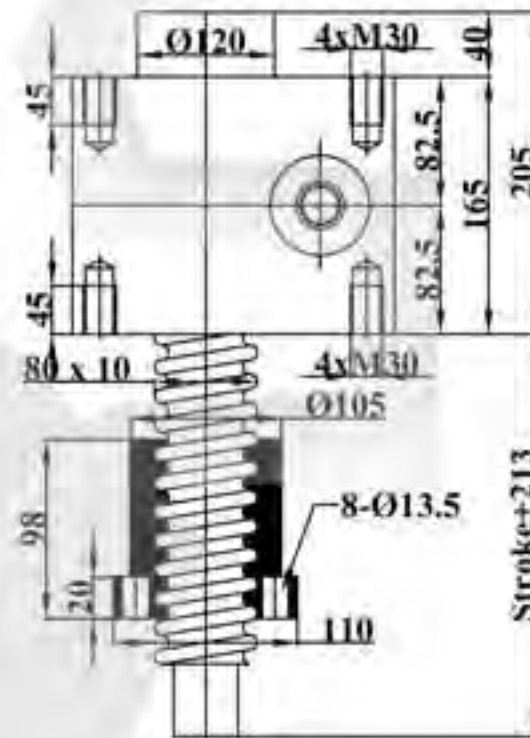

Inverted

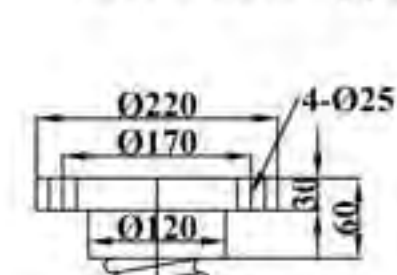

I Top Plate

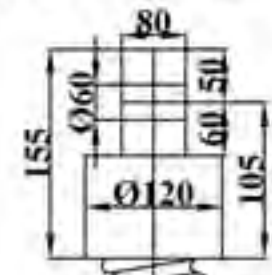

II Clevis End

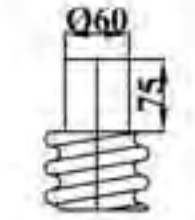

III Plain End

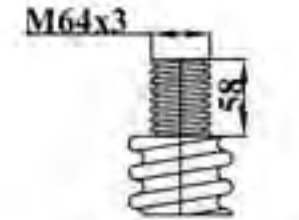

IV Thread End

JTD 300

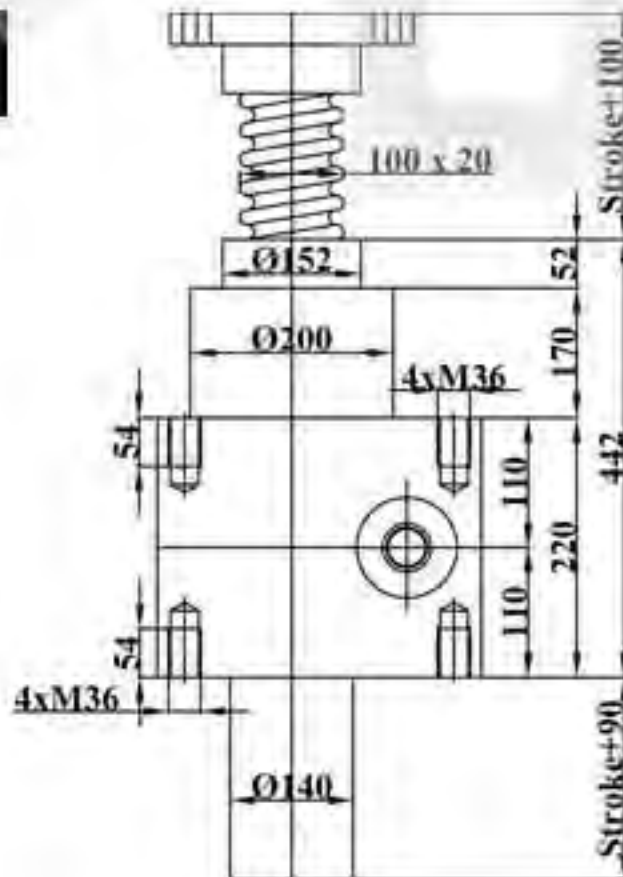

Upright

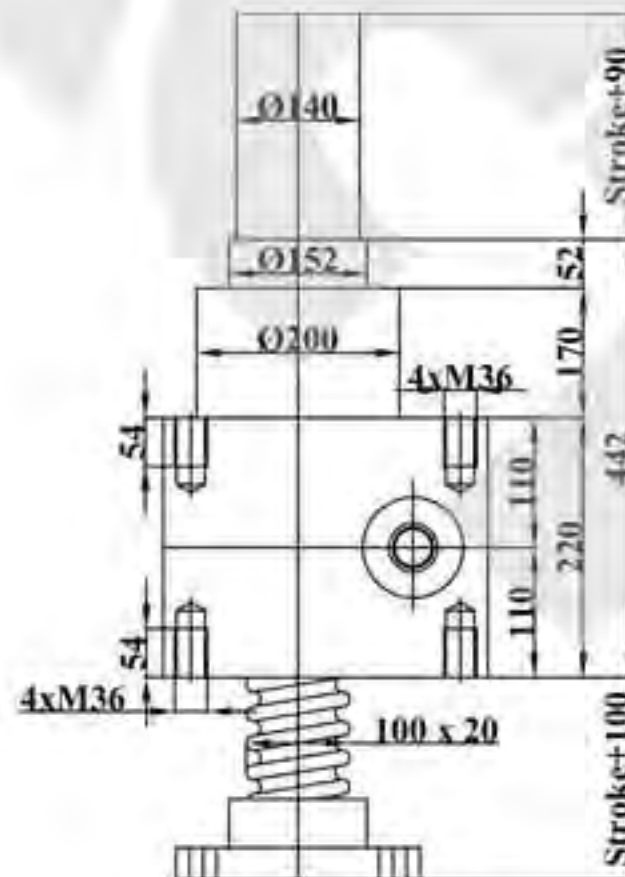

Inverted

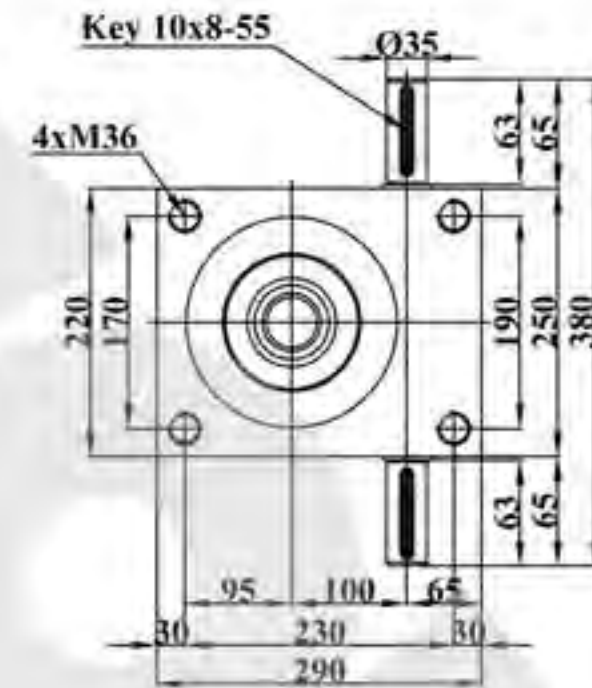

Screw End Types and Dimensions

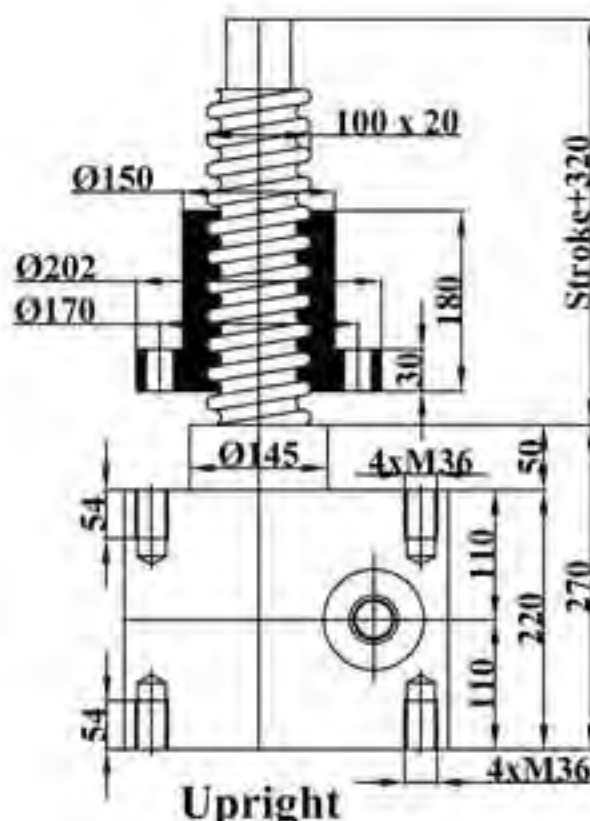

Upright

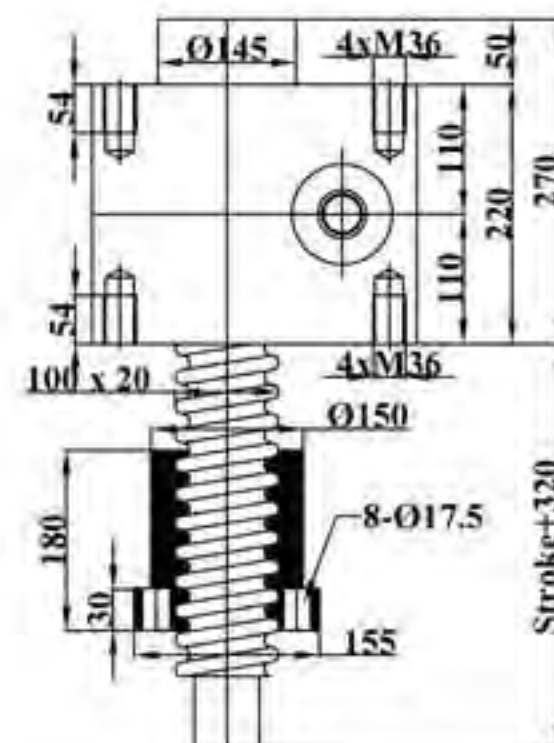

Inverted

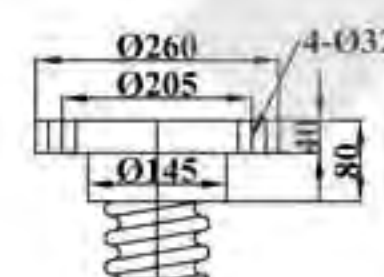

I Top Plate

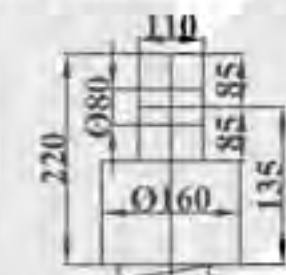

II Clevis End

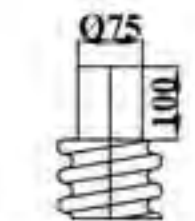

III Plain End

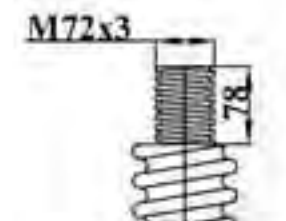

IV Thread End



*. Dimensions are subject to change without notice