

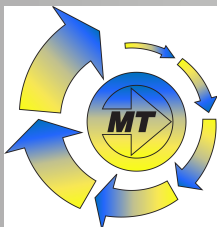

PENTA

D.C. MOTOR

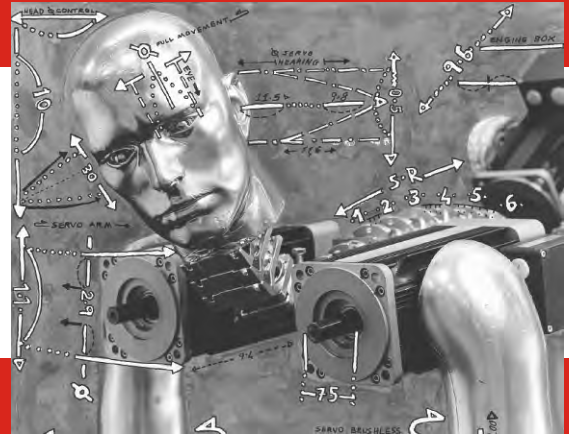
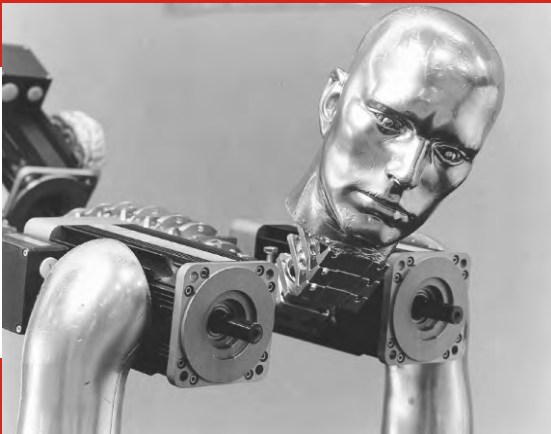

www.motiontech.com.au

**MOTOR
POWER
COMPANY**

www.motorpowergroup.com

PENTA

This direct current motors series, whose power range goes from 45 Watt to 1500Watt, was created after a careful market analysis and represents the right balance among performance-price-quality. Thanks to components such as copper-silver commutator, long-life brushes and ferrite permanent magnets, which are magnetized and calibrated in place, PENTA series assures a high performance competitiveness.



Motor Type	Power Watt		Rated Speed Torque (Nm)	Voltage (Vdc)	Mounting			Ventilation		Dimensions (mm)	
	3000 Rpm	2000 Rpm			B3	B5	B14	Natural	Fan Cooled	Diameter	Length
PENTA 1S	45		0.14	24÷48						57.8	109.5
PENTA 1M	70		0.22								136
PENTA 1L	95		0.30								183.5
PENTA 4S	300	200	0.95	12÷180						116	197.5
PENTA 4M	600	400	1.9	24÷180							227.5
PENTA 4L	900	600	2.86								257.5
PENTA 5X	100	70	0.32	12÷180						83.5	144.5
PENTA 5XS	150	100	0.48								177.5
PENTA 5S	200	135	0.64								212.5
PENTA 5SL	300	200	0.96	24÷180							229
PENTA 5M	360	240	1.15	36÷180							267.5
PENTA 5L	500	335	1.6	48÷180							322.5
PENTA 5XA	150	100	0.48	12÷180						107	189.5
PENTA 5XSA	235	155	0.75								222.5
PENTA 5SA	300	200	0.96	24÷180							257.5
PENTA 5SLA	440	290	1.4								274
PENTA 5MA	565	375	1.8								312.5
PENTA 7SA	750	500	2.4	90÷180						116	318
PENTA 7MA	1100	750	3.5								390
PENTA 7LA	1500	1100	4.8	110÷180							462

- IP 54 protection
- Class F insulation
- Low noise
- High coercive ferrite permanent magnets field
- Skewed armature for higher linearity

SERIE
Series

PENTA 1S

W	RPM
45	3000
	2000

CARATTERISTICHE GENERALI - Performance characteristics

TIPO MOTORE <i>Motor type</i>		1S 30																		
POTENZA RESA <i>Rated power</i>	Pnom [W]			45																
VELOCITA' NOMINALE <i>Rated speed</i>	Nnom [rpm]			3000										2000						
COPPIA NOMINALE <i>Rated torque</i>	Cnom [Nm]			0.143																
TENSIONE NOMINALE <i>Rated voltage</i>	Vnom [V]			48	36	24														
CORRENTE NOMINALE <i>Rated current</i>	Inom [A]			1.3	1.7	2.6														
COPPIA MASSIMA <i>Peak torque</i>	Cmax [Nm]			0.715	0.715	0.715														
CORRENTE MASSIMA <i>Peak current</i>	Imax [A]			6.5	8.5	13														
RESISTENZA ARMATURA <i>Armature resistance</i>	Rarm [Ohm]			6.3	3.33	1.33														
INDUTTANZA ARMATURA <i>Armature inductance</i>	La [mH]			9	4.95	2														
COST. TENSIONE <i>Voltage constant</i>	Ke [V/Krpm]			13	10	6.4														
COST. TEMPO ELET. <i>Elect.time constant</i>	Te [ms]			1.5	1.5	1.5														
COST. TEMPO MECC. <i>Mech.time constant</i>	Tm [ms]			6	5	5														

* Solo per servizio intermittente - Only intermittent duty

DATI MECCANICI - Mechanical data

INERZIA ROTORE <i>Rotor inertia</i>	Jm [Kgcm ²]	0.15
MAX ACC. TEORICA <i>Max theor. Acc.</i>	[Rad/sec ²]	47000
CARICO RADIALE MAX <i>Max radial load</i>	Rl [N]	196
CARICO ASSIALE MAX <i>Max axial load</i>	Al [N]	58
PESO MOTORE <i>Motor weight</i>	G [Kg]	0.95
VENTILAZIONE <i>Ventilation</i>		NATURALE T.E.N.V.
GRADO DI PROTEZIONE <i>Class protection</i>	IP	54

DATI ELETTRICI - Winding data

COST. DI TEMPO TERMICO <i>Thermal time constant</i>	Tt [min]	20
MAX VEL. SENZA CARICO <i>Max no load speed</i>	No max [rpm]	4000
MAX VEL. CON CARICO <i>Max load speed</i>	N max [rpm]	3000
CLASSE D'ISOLAMENTO <i>Insulation class</i>		F
FATTORE DI SERVIZIO <i>Duty cycle</i>		S1
FATTORE DI FORMA <i>Form factor</i>	FF	1
TEMP. AMBIENTE RIF. DATI <i>Room temp. data refer.</i>	T rif [°C]	40°

MOTORI IN CORRENTE CONTINUA

D.C. MOTORS



SERIE
Series

PENTA

1M

W	RPM
70	3000
	2000

CARATTERISTICHE GENERALI - Performance characteristics

TIPO MOTORE <i>Motor type</i>		1M30																			
POTENZA RESA <i>Rated power</i>	P _{nom} [W]		70																		
VELOCITA' NOMINALE <i>Rated speed</i>	N _{nom} [rpm]		3000																		2000
COPPIA NOMINALE <i>Rated torque</i>	C _{nom} [Nm]		0.22																		
TENSIONE NOMINALE <i>Rated voltage</i>	V _{nom} [V]			48	36	24															
CORRENTE NOMINALE <i>Rated current</i>	I _{nom} [A]			1.95	2.6	3.65															
COPPIA MASSIMA <i>Peak torque</i>	C _{max} [Nm]			1.1	1.1	1.1															
CORRENTE MASSIMA <i>Peak current</i>	I _{max} [A]			9.75	13	18.25															
RESISTENZA ARMATURA <i>Armature resistance</i>	R _{arm} [Ohm]			2.33	1.85	0.85															
INDUTTANZA ARMATURA <i>Armature inductance</i>	L _a [mH]			4	3	1.34															
COST. TENSIONE <i>Voltage constant</i>	K _e [V/Krpm]			13.2	10.4	7.3															
COST. TEMPO ELET. <i>Elect. time constant</i>	T _e [ms]			1.7	1.62	1.58															
COST. TEMPO MECC. <i>Mech. time constant</i>	T _m [ms]			6.5	6	6															

* Solo per servizio intermittente - Only intermittent duty

DATI MECCANICI - Mechanical data

INERZIA ROTORE <i>Rotor inertia</i>	J _m [Kgcm ²]		0.324	
MAX ACC. TEORICA <i>Max theor. Acc.</i>	[Rad/sec ²]		33950	
CARICO RADIALE MAX <i>Max radial load</i>	R _I [N]		196	
CARICO ASSIALE MAX <i>Max axial load</i>	A _I [N]		58	
PESO MOTORE <i>Motor weight</i>	G [Kg]		1.3	
VENTILAZIONE <i>Ventilation</i>			NATURALE T.E.N.V.	
GRADO DI PROTEZIONE <i>Class protection</i>	IP		54	

DATI ELETTRICI - Winding data

COST. DI TEMPO TERMICO <i>Thermal time constant</i>	T _t [min]		25	
MAX VEL. SENZA CARICO <i>Max no load speed</i>	No max [rpm]		4000	
MAX VEL. CON CARICO <i>Max load speed</i>	N max [rpm]		3000	
CLASSE D'ISOLAMENTO <i>Insulation class</i>			F	
FATTORE DI SERVIZIO <i>Duty cycle</i>			S1	
FATTORE DI FORMA <i>Form factor</i>	FF		1	
TEMP. AMBIENTE RIF. DATI <i>Room temp. data refer.</i>	T rif [°C]		40°	

MOTORI IN CORRENTE CONTINUA

D.C. MOTORS



SERIE
Series

PENTA

1L

W	RPM
95	3000
	2000

CARATTERISTICHE GENERALI - Performance characteristics

TIPO MOTORE <i>Motor type</i>		1L 30																			
POTENZA RESA <i>Rated power</i>	P _{nom} [W]			95																	
VELOCITA' NOMINALE <i>Rated speed</i>	N _{nom} [rpm]			3000																	
COPPIA NOMINALE <i>Rated torque</i>	C _{nom} [Nm]			0.3																	
TENSIONE NOMINALE <i>Rated voltage</i>	V _{nom} [V]			48	36	24															
CORRENTE NOMINALE <i>Rated current</i>	I _{nom} [A]			2.5	3.4	4.9															
COPPIA MASSIMA <i>Peak torque</i>	C _{max} [Nm]			1.5	1.5	1.5															
CORRENTE MASSIMA <i>Peak current</i>	I _{max} [A]			12.5	17	24.5															
RESISTENZA ARMATURA <i>Armature resistance</i>	R _{arm} [Ohm]			2.43	1.19	0.48															
INDUTTANZA ARMATURA <i>Armature inductance</i>	L _a [mH]			3	1.65	0.7															
COST. TENSIONE <i>Voltage constant</i>	K _e [V/Krpm]			13.3	10.7	7.5															
COST. TEMPO ELET. <i>Elect. time constant</i>	T _e [ms]			1.24	1.4	1.46															
COST. TEMPO MECC. <i>Mech. time constant</i>	T _m [ms]			9	7	6															

* Solo per servizio intermittente - Only intermittent duty

DATI MECCANICI - Mechanical data

INERZIA ROTORE <i>Rotor inertia</i>	J _m [Kgcm ²]	0.607
MAX ACC. TEORICA <i>Max theor. Acc.</i>	[Rad/sec ²]	24711
CARICO RADIALE MAX <i>Max radial load</i>	R _I [N]	196
CARICO ASSIALE MAX <i>Max axial load</i>	A _I [N]	58
PESO MOTORE <i>Motor weight</i>	G [Kg]	1,85
VENTILAZIONE <i>Ventilation</i>		NATURALE T.E.N.V.
GRADO DI PROTEZIONE <i>Class protection</i>	IP	54

DATI ELETTRICI - Winding data

COST. DI TEMPO TERMICO <i>Thermal time constant</i>	T _t [min]	30
MAX VEL. SENZA CARICO <i>Max no load speed</i>	No max [rpm]	4000
MAX VEL. CON CARICO <i>Max load speed</i>	N max [rpm]	3000
CLASSE D'ISOLAMENTO <i>Insulation class</i>		F
FATTORE DI SERVIZIO <i>Duty cycle</i>		S1
FATTORE DI FORMA <i>Form factor</i>	FF	1
TEMP. AMBIENTE RIF. DATI <i>Room temp. data refer.</i>	T _{rif} [°C]	40°

PENTA 1

MOTORI C.C.

D.C. MOTORS



DIMENSIONI (mm) DIMENSIONS (mm)

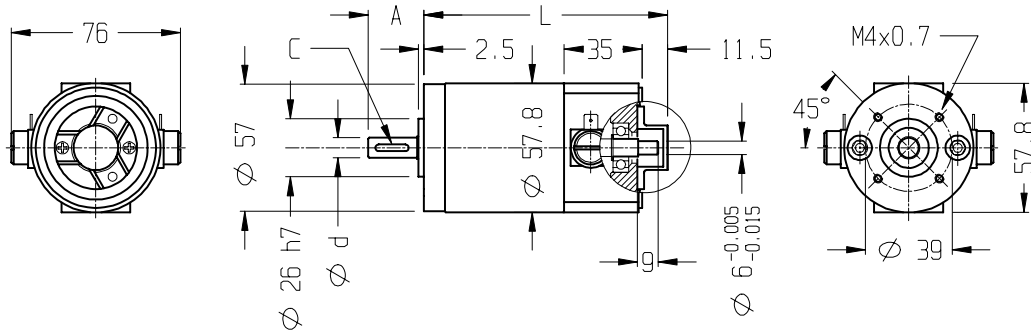

Type	S	M	L
A	20		25
L	109.5	136	183.5
d (j6)	7		9
C	-		3x3x15

MORSETTIERA

TERMINAL BOX

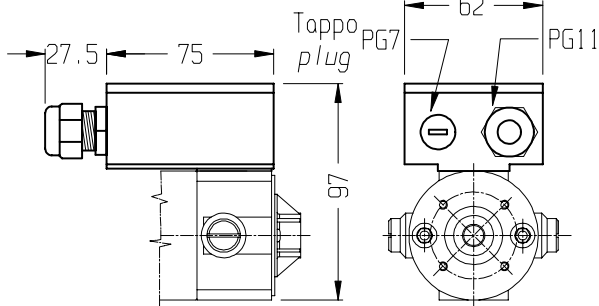

CONNETTORE

CONNECTOR

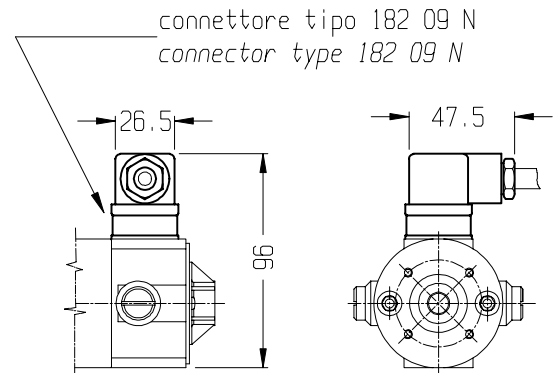

CAVO

FLYING LEADS

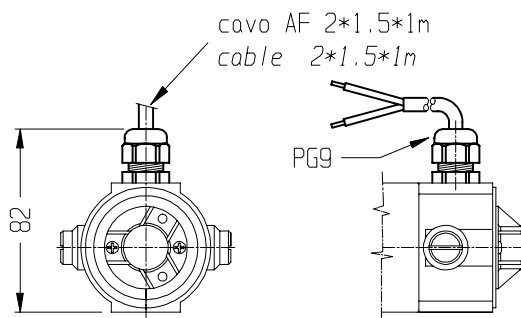

FLANGIA B14/56

B14/56 FLANGE

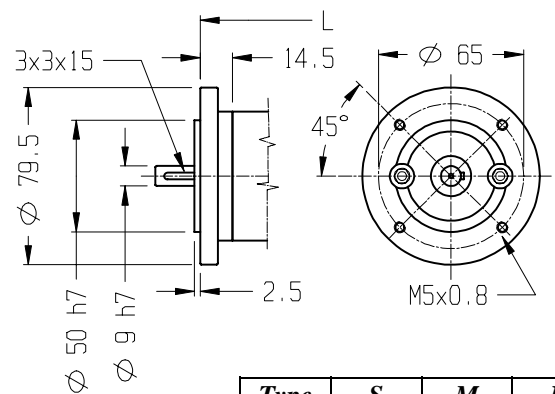

Type	S	M	L
L	114.5	141	188.5

OPTIONALS

PIEDE A FASCIA

FOOT BAND TYPE

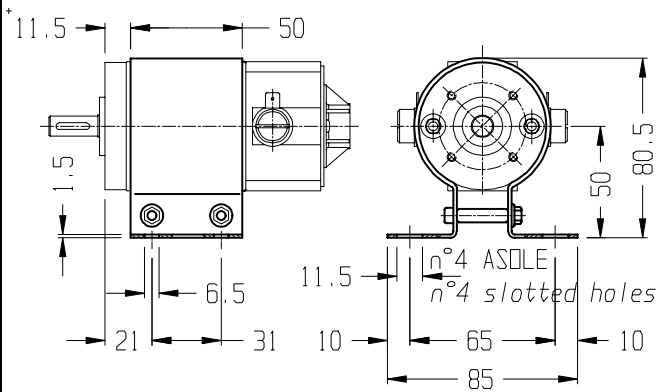

PRED. ENCODER

ENC. PREARRANGEMENT

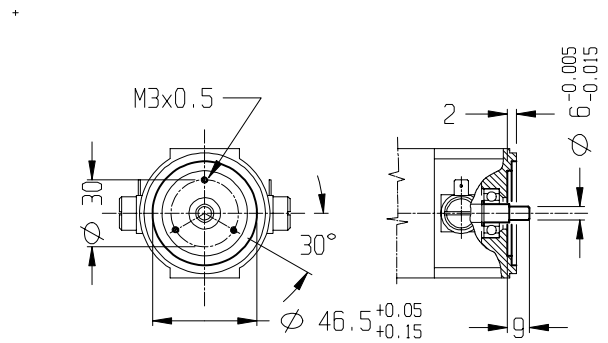

ENCODER EH53

EH53 ENCODER

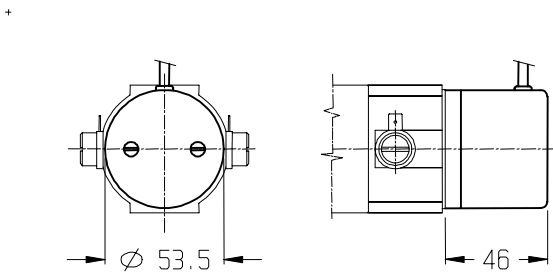

ENCODER EH38

EH38 ENCODER

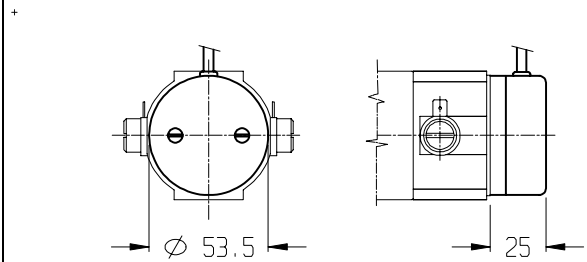

DISTANZ. ENC. N°1

ENCODER SPACER N°1

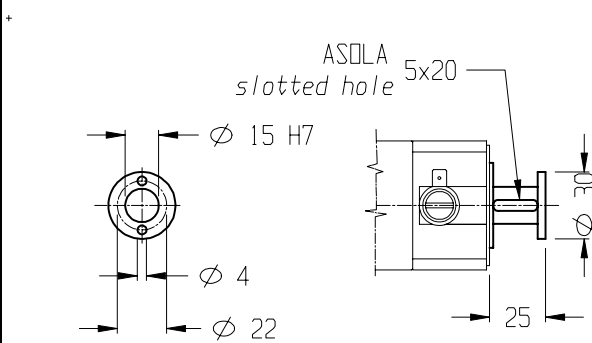

DISTANZ. ENC. N°2

ENCODER SPACER N°2

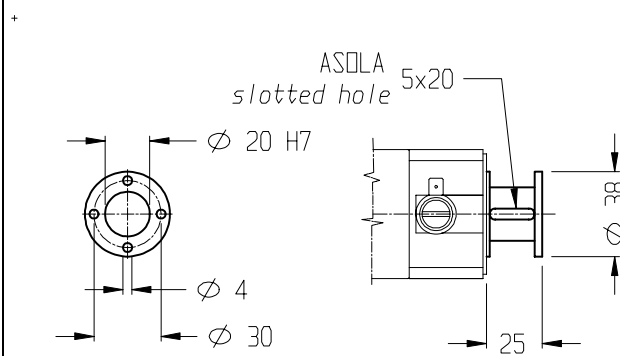

OPTIONALS

DIN. TACHIMETRICA TACHO GENERATOR

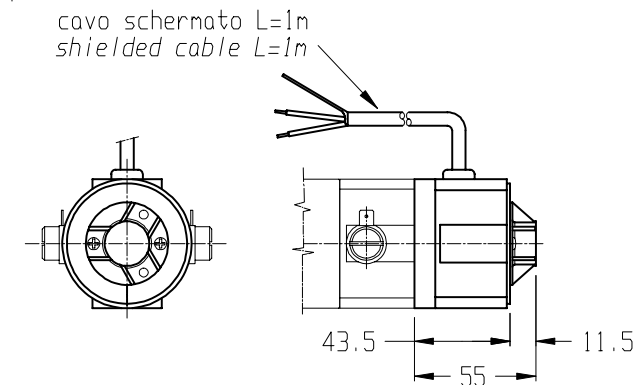

PREDISPOSTO ENCODER ENCODER PREARRANGEMENT

COSTANTE DI TENSIONE VOLTAGE CONSTANT	10±5% V/KRPM	CORRENTE NOMINALE RATED CURRENT	2 mA
VELOCITA' MASSIMA MAX SPEED	9000 RPM	CORRENTE MASSIMA MAX CURRENT	8 mA

FRENO 0.5 Nm BRAKE 0.5 Nm

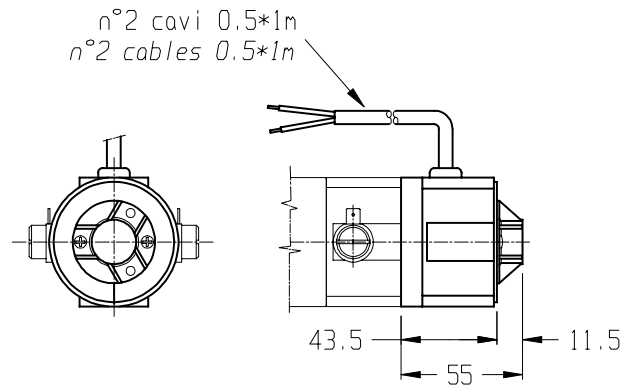

PREDISPOSTO ENCODER ENCODER PREARRANGEMENT

COPPIA STATICA STATIC TORQUE	0.5 Nm	CORRENTE CURRENT	0.42 A
TENSIONE DI ALIMEN. POWER SUPPLY VOLTAGE	24 V.c.c.	POTENZA ASSORBITA INPUT POWER	10 W

FRENO 0.5 Nm + DIN. TACHO GENERATOR + TACHIMETRICA BRAKE 0.5 Nm

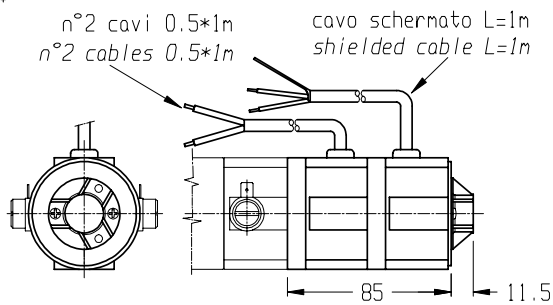

PREDISPOSTO ENCODER ENCODER PREARRANGEMENT

	FRENO BRAKE	DINAMO T. TACHO G.	
COPPIA STATICA STATIC TORQUE	0.5 Nm	COSTANTE DI TENSIONE VOLTAGE CONSTANT	10±5% V/KRPM
TENSIONE DI ALIMEN. POWER SUPPLY VOLTAGE	24 V.c.c.	VELOCITA' MASSIMA MAX SPEED	9000 RPM
CORRENTE CURRENT	0.42 A	CORRENTE NOMINALE RATED CURRENT	2 mA
POTENZA ASSORBITA INPUT POWER	10 W	CORRENTE MASSIMA MAX CURRENT	8 mA

SERIE
Series

PENTA 4S

W	RPM
300	3000
200	2000

CARATTERISTICHE GENERALI - Performance characteristics

TIPO MOTORE	4S 30								4S20								
<i>Motor type</i>																	
POTENZA RESA <i>Rated power</i>	P _{nom} [W]	300								200							
VELOCITA' NOMINALE <i>Rated speed</i>	N _{nom} [rpm]	3000								2000							
COPPIA NOMINALE <i>Rated torque</i>	C _{nom} [Nm]	0.95								0.95							
TENSIONE NOMINALE <i>Rated voltage</i>	V _{nom} [V]	180	90	60	48	36	24	12	180	90	60	48	36	24	12		
CORRENTE NOMINALE <i>Rated current</i>	I _{nom} [A]	2.22	4.44	6.67	8.33	11.11	16.67	33.33	1.48	2.96	4.44	5.56	7.41	11.11	22.22		
COPPIA MASSIMA <i>Peak torque</i>	C _{max} [Nm]				4.76							4.76					
CORRENTE MASSIMA <i>Peak current</i>	I _{max} [A]	11.1	22.2	33.3	41.7	55.6	83.3	166.7	7.4	14.8	22.2	27.8	37.0	55.6	111.1		
RESISTENZA ARMATURA <i>Armature resistance</i>	R _{arm} [Ohm]	7.36	1.91	1.19	0.91	0.62	0.23	0.09	16.99	3.66	1.94	1.92	1.20	0.47	0.16		
INDUTTANZA ARMATURA <i>Armature inductance</i>	L _a [mH]	30.00	7.50	3.59	0.90	0.51	0.23	0.06	80.00	19.50	8.67	2.05	1.12	0.51	0.14		
COST. TENSIONE <i>Voltage constant</i>	K _e [V/Krpm]	54.5	27.3	18.2	14.5	10.6	7.1	3.5	81.8	40.9	27.3	21.8	15.9	10.6	5.2		
COST. TEMPO ELET. <i>Elect. time constant</i>	T _e [ms]	4.08	3.93	3.02	0.99	0.81	0.98	0.59	4.71	5.32	4.47	1.07	0.93	1.09	0.88		
COST. TEMPO MECC. <i>Mech. time constant</i>	T _m [ms]	31.2	32.3	45.4	54.4	69.8	58.1	98.9	32.0	27.6	32.9	50.8	60.1	53.0	74.3		

* Solo per servizio intermittente - Intermittent duty only

DATI MECCANICI - Mechanical data

INERZIA ROTORE <i>Rotor inertia</i>	J _m [Kgm ²]	0.00115
MAX ACC. TEORICA <i>Max theor. Acc.</i>	[Rad/sec ²]	4141
CARICO RADIALE MAX <i>Max radial load</i>	R _I [N]	360
CARICO ASSIALE MAX <i>Max axial load</i>	A _I [N]	108
PESO MOTORE <i>Motor weight</i>	G [Kg]	5.3
VENTILAZIONE <i>Ventilation</i>	NATURALE T.E.N.V.	
GRADO DI PROTEZIONE <i>Class protection</i>	IP	54

DATI ELETTRICI - Winding data

COST. DI TEMPO TERMICO <i>Thermal time constant</i>	T _t [min]	30
MAX VEL. SENZA CARICO <i>Max no load speed</i>	No max [rpm]	4000
MAX VEL. CON CARICO <i>Max load speed</i>	N max [rpm]	3000
CLASSE D'ISOLAMENTO <i>Insulation class</i>	F	
FATTORE DI SERVIZIO <i>Duty cycle</i>	S1	
FATTORE DI FORMA <i>Form factor</i>	FF	1
TEMP. AMBIENTE RIF. DATI <i>Room temp. data refer.</i>	T _{rif} [°C]	40°

SERIE
Series

PENTA 4M

W	RPM
600	3000
400	2000

CARATTERISTICHE GENERALI - Performance characteristics

TIPO MOTORE		4M 30								4M20							
<i>Motor type</i>																	
POTENZA RESA	P _{nom}																
<i>Rated power</i>	[W]	600								400							
VELOCITA' NOMINALE	N _{nom}																
<i>Rated speed</i>	[rpm]	3000								2000							
COPPIA NOMINALE	C _{nom}																
<i>Rated torque</i>	[Nm]	1.90								1.90							
TENSIONE NOMINALE	V _{nom}																
<i>Rated voltage</i>	[V]	180	90	60	48	36	24	12*	180	90	60	48	36	24	12*		
CORRENTE NOMINALE	I _{nom}																
<i>Rated current</i>	[A]	4.44	8.89	13.33	16.67	22.22	33.33	66.67	2.96	5.93	8.89	11.11	14.81	22.22	44.44		
COPPIA MASSIMA	C _{max}																
<i>Peak torque</i>	[Nm]	9.52								9.52							
CORRENTE MASSIMA	I _{max}																
<i>Peak current</i>	[A]	22.2	44.4	66.7	83.3	111.1	166.7	333.3	14.8	29.6	44.4	55.6	74.1	111.1	222.2		
RESISTENZA ARMATURA	R _{arm}																
<i>Armature resistance</i>	[Ohm]	2.84	0.96	0.59	0.52	0.40	0.13	0.08	4.79	1.62	0.81	0.95	0.54	0.23	0.11		
INDUTTANZA ARMATURA	L _a																
<i>Armature inductance</i>	[mH]	12.80	2.98	1.23	0.45	0.28	0.11	0.02	27.00	6.75	3.00	1.05	0.54	0.24	0.06		
COST. TENSIONE	K _e																
<i>Voltage constant</i>	[V/Krpm]	56.3	27.3	18.2	14.5	10.6	7.1	3.5	81.8	40.9	27.3	21.8	15.9	10.6	5.2		
COST. TEMPO ELET.	T _e																
<i>Elect.time constant</i>	[ms]	4.50	3.12	2.09	0.87	0.70	0.87	0.25	5.64	4.16	3.72	1.10	0.99	1.04	0.56		
COST. TEMPO MECC.	T _m																
<i>Mech.time constant</i>	[ms]	20.2	28.9	40.2	55.3	79.4	58.6	156.6	16.1	21.8	24.4	44.9	48.4	45.8	88.5		

* Solo per servizio intermittente - Intermittent duty only

DATI MECCANICI - Mechanical data

INERZIA ROTORE	J _m	
<i>Rotor inertia</i>	[Kgm ²]	0.00205
MAX ACC. TEORICA		
<i>Max theor. Acc.</i>	[Rad/sec ²]	4646
CARICO RADIALE MAX	R _I	
<i>Max radial load</i>	[N]	360
CARICO ASSIALE MAX	A _I	
<i>Max axial load</i>	[N]	108
PESO MOTORE	G	
<i>Motor weight</i>	[Kg]	6,8
VENTILAZIONE		NATURALE
<i>Ventilation</i>		T.E.N.V.
GRADO DI PROTEZIONE		
<i>Class protection</i>	IP	54

DATI ELETTRICI - Winding data

COST. DI TEMPO TERMICO	T _t	
<i>Thermal time constant</i>	[min]	40
MAX VEL. SENZA CARICO	No max	
<i>Max no load speed</i>	[rpm]	4000
MAX VEL. CON CARICO	N max	
<i>Max load speed</i>	[rpm]	3000
CLASSE D'ISOLAMENTO		
<i>Insulation class</i>		F
FATTORE DI SERVIZIO		
<i>Duty cycle</i>		S1
FATTORE DI FORMA		
<i>Form factor</i>	FF	1
TEMP. AMBIENTE RIF. DATI	T _{rif}	
<i>Room temp. data refer.</i>	[°C]	40°

SERIE
Series

PENTA 4L

W	RPM
900	3000
600	2000

CARATTERISTICHE GENERALI - Performance characteristics

TIPO MOTORE	4L 30								4L20								
<i>Motor type</i>																	
POTENZA RESA <i>Rated power</i>	P _{nom} [W]	900								600							
VELOCITA' NOMINALE <i>Rated speed</i>	N _{nom} [rpm]	3000								2000							
COPPIA NOMINALE <i>Rated torque</i>	C _{nom} [Nm]	2.86								2.86							
TENSIONE NOMINALE <i>Rated voltage</i>	V _{nom} [V]	180	90	60	48	36	24*	12*	180	90	60	48	36	24	12*		
CORRENTE NOMINALE <i>Rated current</i>	I _{nom} [A]	6.67	13.33	20.00	25.00	33.33	50.00	100.00	4.44	8.89	13.33	16.67	22.22	33.33	66.67		
COPPIA MASSIMA <i>Peak torque</i>	C _{max} [Nm]	14.29								14.29							
CORRENTE MASSIMA <i>Peak current</i>	I _{max} [A]	33.3	66.7	100.00	125.0	166.7	250.0	500.0	22.2	44.4	66.7	83.3	111.1	166.7	333.3		
RESISTENZA ARMATURA <i>Armature resistance</i>	R _{arm} [Ohm]	1.73	0.69	0.45	0.36	0.28	0.11	0.07	2.50	0.85	0.49	0.53	0.36	0.13	0.09		
INDUTTANZA ARMATURA <i>Armature inductance</i>	L _a [mH]	7.50	1.88	0.35	0.25	0.12	0.06	0.01	12.70	3.18	1.52	0.48	0.24	0.12	0.02		
COST. TENSIONE <i>Voltage constant</i>	K _e [V/Krpm]	57.1	27.3	18.2	14.5	10.6	7.1	3.5	81.8	40.9	27.3	21.8	15.9	10.6	5.2		
COST. TEMPO ELET. <i>Elect. time constant</i>	T _e [ms]	4.34	2.70	0.78	0.67	0.42	0.56	0.13	5.08	3.75	3.08	0.90	0.67	0.90	0.26		
COST. TEMPO MECC. <i>Mech. time constant</i>	T _m [ms]	16.8	29.7	43.5	54.7	80.2	69.6	193.6	11.9	16.1	21.1	35.5	45.8	37.7	99.9		

* Solo per servizio intermittente - Intermittent duty only

DATI MECCANICI - Mechanical data

INERZIA ROTORE <i>Rotor inertia</i>	J _m [Kgm ²]	0.0029
MAX ACC. TEORICA <i>Max theor. Acc.</i>	[Rad/sec ²]	4946
CARICO RADIALE MAX <i>Max radial load</i>	R _I [N]	360
CARICO ASSIALE MAX <i>Max axial load</i>	A _I [N]	108
PESO MOTORE <i>Motor weight</i>	G [Kg]	8,3
VENTILAZIONE <i>Ventilation</i>	NATURALE T.E.N.V.	
GRADO DI PROTEZIONE <i>Class protection</i>	IP	54

DATI ELETTRICI - Winding data

COST. DI TEMPO TERMICO <i>Thermal time constant</i>	T _t [min]	60
MAX VEL. SENZA CARICO <i>Max no load speed</i>	No max [rpm]	4000
MAX VEL. CON CARICO <i>Max load speed</i>	N max [rpm]	3000
CLASSE D'ISOLAMENTO <i>Insulation class</i>	F	
FATTORE DI SERVIZIO <i>Duty cycle</i>	S1	
FATTORE DI FORMA <i>Form factor</i>	FF	1
TEMP. AMBIENTE RIF. DATI <i>Room temp. data refer.</i>	T _{rif} [°C]	40°

PENTA 4

MOTORI C.C.

D.C. MOTORS



OPTIONALS

PRED. ENCODER *ENC. PREARRANGEMENT*

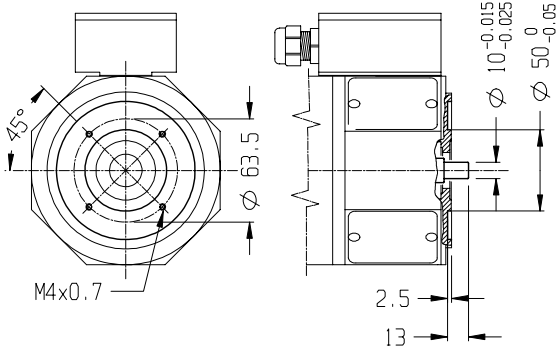

ENCODER EL72

EL72 ENCODER

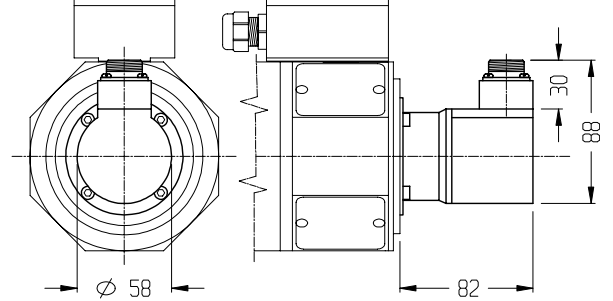

DISTANZ. ENC. N°1

ENC. SPACER N°1

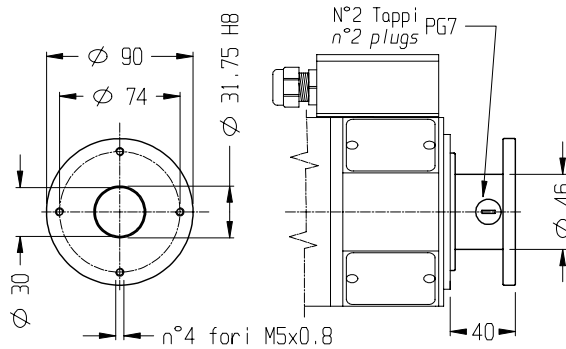

DIN. TACHIMETRICA

TACHO GENERATOR

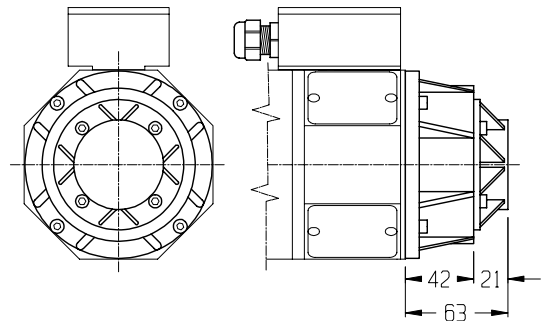

COSTANTE DI TENSIONE <i>VOLTAGE CONSTANT</i>	10±5% V/KRPM	CORRENTE NOMINALE <i>RATED CURRENT</i>	2 mA
VELOCITA' MASSIMA <i>MAX SPEED</i>	9000 RPM	CORRENTE MASSIMA <i>MAX CURRENT</i>	8 mA

FRENO N°1: 1,7 Nm

BRAKE N°1: 1,7 Nm

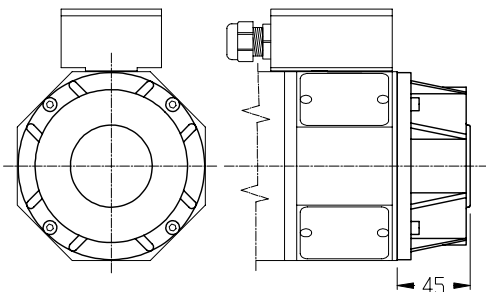

COPPIA STATICA <i>STATIC TORQUE</i>	1,7 Nm	CORRENTE <i>CURRENT</i>	0.46-0.058 A
TENSIONE DI ALIMEN. <i>POWER SUPPLY VOLTAGE</i>	24-190 V.c.c.	POTENZA ASSORBITA <i>INPUT POWER</i>	11 W

FRENO N°2: 4 Nm

BRAKE N°2: 4 Nm

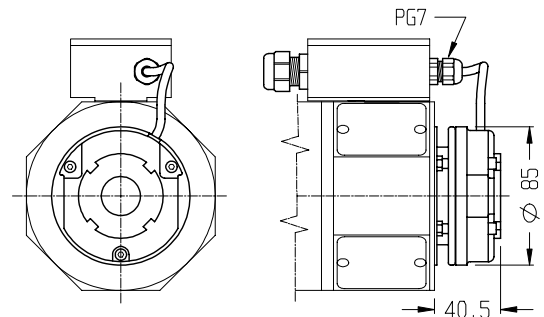

COPPIA STATICA <i>STATIC TORQUE</i>	4 Nm	CORRENTE <i>CURRENT</i>	0.83-0.109 A
TENSIONE DI ALIMEN. <i>POWER SUPPLY VOLTAGE</i>	24-190 V.c.c.	POTENZA ASSORBITA <i>INPUT POWER</i>	20 W

MOTORI IN CORRENTE CONTINUA

D.C. MOTORS



SERIE
Series

PENTA 5X

W	RPM
100	3000
70	2000

CARATTERISTICHE GENERALI - Performance characteristics

TIPO MOTORE	5X 30								5X20								
<i>Motor type</i>																	
POTENZA RESA <i>Rated power</i>	Pnom [W]	100								70							
VELOCITA' NOMINALE <i>Rated speed</i>	Nnom [rpm]	3000								2000							
COPPIA NOMINALE <i>Rated torque</i>	Cnom [Nm]	0.32								0.32							
TENSIONE NOMINALE <i>Rated voltage</i>	Vnom [V]	180	90	60	48	36	24	12	180	90	60	48	33	24	12		
CORRENTE NOMINALE <i>Rated current</i>	Inom [A]	0.74	1.5	2.2	2.8		5.54	11	0.55	1.1	1.6	2	2.8	4	8		
COPPIA MASSIMA <i>Peak torque</i>	Cmax [Nm]	1.6	1.6	1.6	1.6		1.6	1.6	1.6	1.6	1.6	1.6	1.6	1.6	1.6		
CORRENTE MASSIMA <i>Peak current</i>	Imax [A]	3.7	7.5	11	14		27.7	55	2.75		8	10	14	20	40		
RESISTENZA ARMATURA <i>Armature resistance</i>	Rarm [Ohm]	16.7	4.1	1.8	1.28		0.4	0.12	41.1		4.1	2.4	1.28	0.86	0.25		
INDUTTANZA ARMATURA <i>Armature inductance</i>	La [mH]	46.5	10.25	4.15	2.95		0.8	0.19	135	35.4	10.25	5.75	2.95	1.75	0.5		
COST. TENSIONE <i>Voltage constant</i>	Ke [V/Krpm]	54	27	17	15		7	3.4	82	40	26	20	15	9.6	5		
COST. TEMPO ELET. <i>Elect.time constant</i>	Te [ms]	2.8	2.5	2.3	2.3		2	1.6	3.3		2.5	2.4	2.3	2.1	1.6		
COST. TEMPO MECC. <i>Mech.time constant</i>	Tm [ms]	11	11	12	11		16	20	12		11	12	11	15	19		

* Solo per servizio intermittente - Only intermittent duty

DATI MECCANICI - Mechanical data

INERZIA ROTORE <i>Rotor inertia</i>	Jm [Kgm ²]	0.00018
MAX ACC. TEORICA <i>Max theor. Acc.</i>	[Rad/sec ²]	8800
CARICO RADIALE MAX <i>Max radial load</i>	RI [N]	294
CARICO ASSIALE MAX <i>Max axial load</i>	AI [N]	88
PESO MOTORE <i>Motor weight</i>	G [Kg]	2.9
VENTILAZIONE <i>Ventilation</i>	NATURALE T.E.N.V.	
GRADO DI PROTEZIONE <i>Class protection</i>	IP	54

DATI ELETTRICI - Winding data

COST. DI TEMPO TERMICO <i>Thermal time constant</i>	Tt [min]	20
MAX VEL. SENZA CARICO <i>Max no load speed</i>	No max [rpm]	4000
MAX VEL. CON CARICO <i>Max load speed</i>	N max [rpm]	3000
CLASSE D'ISOLAMENTO <i>Insulation class</i>	F	
FATTORE DI SERVIZIO <i>Duty cycle</i>	S1	
FATTORE DI FORMA <i>Form factor</i>	FF	1
TEMP. AMBIENTE RIF. DATI <i>Room temp. data refer.</i>	T rif [°C]	40°

MOTORI IN CORRENTE CONTINUA

D.C. MOTORS



SERIE
Series

PENTA 5XS

W	RPM
150	3000
100	2000

CARATTERISTICHE GENERALI - Performance characteristics

TIPO MOTORE <i>Motor type</i>		5XS 30								5XS 20							
POTENZA RESA <i>Rated power</i>	P _{nom} [W]	150								100							
VELOCITA' NOMINALE <i>Rated speed</i>	N _{nom} [rpm]	3000								2000							
COPPIA NOMINALE <i>Rated torque</i>	C _{nom} [Nm]	0.48								0.48							
TENSIONE NOMINALE <i>Rated voltage</i>	V _{nom} [V]	180	90	60	48	36	24	12	180	90	60	48	36	24	12		
CORRENTE NOMINALE <i>Rated current</i>	I _{nom} [A]	1.1	2.2	3.3	4.2	5.55	8.33	16	0.74	1.5	2.2	2.8	3.7	5.54	11		
COPPIA MASSIMA <i>Peak torque</i>	C _{max} [Nm]	2.4	2.4	2.4	2.4	2.4	2.4	2.4	2.4	2.4	2.4	2.4		2.4	2.4		
CORRENTE MASSIMA <i>Peak current</i>	I _{max} [A]	5.5		16.7	21		41.7	80	3.7		11	14		27.7	55		
RESISTENZA ARMATURA <i>Armature resistance</i>	R _{arm} [Ohm]	13.9	4.04	1.64	1.1		0.29	0.12	26.9		3.5	2.6		0.54	0.184		
INDUTTANZA ARMATURA <i>Armature inductance</i>	L _a [mH]	47	11	5.4	3.5	1.92	0.73	0.165	100	29	10.9	7.5	4.7	1.3	2.2		
COST. TENSIONE <i>Voltage constant</i>	K _e [V/Krpm]	54		18	15		7	3.4	82		26	20		9.6	5		
COST. TEMPO ELET. <i>Elect. time constant</i>	T _e [ms]	3.4	3.2	3.29	3.2	3.5	2.5	1.4	3.7	3.5	3.2	2.9	3.4	2.4	2.2		
COST. TEMPO MECC. <i>Mech. time constant</i>	T _m [ms]	15		17	16		19	34	13		17	21		19	24		

* Solo per servizio intermittente - Only intermittent duty

DATI MECCANICI - Mechanical data

INERZIA ROTORE <i>Rotor inertia</i>	J _m [Kgm ²]	0.0003
MAX ACC. TEORICA <i>Max theor. Acc.</i>	[Rad/sec ²]	8000
CARICO RADIALE MAX <i>Max radial load</i>	R _I [N]	294
CARICO ASSIALE MAX <i>Max axial load</i>	A _I [N]	88
PESO MOTORE <i>Motor weight</i>	G [Kg]	3.5
VENTILAZIONE <i>Ventilation</i>		NATURALE T.E.N.V.
GRADO DI PROTEZIONE <i>Class protection</i>	IP	54

DATI ELETTRICI - Winding data

COST. DI TEMPO TERMICO <i>Thermal time constant</i>	T _t [min]	25
MAX VEL. SENZA CARICO <i>Max no load speed</i>	No max [rpm]	4000
MAX VEL. CON CARICO <i>Max load speed</i>	N max [rpm]	3000
CLASSE D'ISOLAMENTO <i>Insulation class</i>		F
FATTORE DI SERVIZIO <i>Duty cycle</i>		S1
FATTORE DI FORMA <i>Form factor</i>	FF	1
TEMP. AMBIENTE RIF. DATI <i>Room temp. data refer.</i>	T _{rif} [°C]	40°

SERIE
Series

PENTA 5S

W	RPM
200	3000
135	2000

CARATTERISTICHE GENERALI - Performance characteristics

TIPO MOTORE	5S 30								5S 20								
Motor type																	
POTENZA RESA Rated power	Pnom [W]	200								135							
VELOCITA' NOMINALE Rated speed	Nnom [rpm]	3000								2000							
COPPIA NOMINALE Rated torque	Cnom [Nm]	0.64								0.64							
TENSIONE NOMINALE Rated voltage	Vnom [V]	180	90	60	48	36	24	12*	180	88	60	46	36	24	12		
CORRENTE NOMINALE Rated current	Inom [A]	1.4	2.85	4.3	5.3	7	10.7		0.97	2.1	2.9	3.8	4.8	7.25	14.5		
COPPIA MASSIMA Peak torque	Cmax [Nm]	3.2	3.2	3.2	3.2	3.2	3.2		3.2	3.2	3.2	3.2	3.2	3.2	3.2		
CORRENTE MASSIMA Peak current	Imax [A]	7		21.5	26.5		53.5		4.85	10.5	14.5	19		36	72.5		
RESISTENZA ARMATURA Armature resistance	Rarm [Ohm]	6.15		0.92	0.6		0.17		15.5	3	1.36	0.96	1.08	0.33	0.12		
INDUTTANZA ARMATURA Armature inductance	La [mH]	20	5.79	2.5	1.5	0.76	0.32		49	11	3.9	2.67	1.77	0.73	0.16		
COST. TENSIONE Voltage constant	Ke [V/Krpm]	54	28.5	18	15		7		82	40	26	20	16.6	9.6	5		
COST. TEMPO ELET. Elect. time constant	Te [ms]	3.3	3.33	2.7	2.5		1.9		3.2	3.7	2.9	2.8		2.2	1.7		
COST. TEMPO MECC. Mech. time constant	Tm [ms]	14		19	17		23		15	12	13	16		21	31		

* Solo per servizio intermittente - Only intermittent duty

DATI MECCANICI - Mechanical data

INERZIA ROTORE Rotor inertia	Jm [Kgm ²]	0.0006
MAX ACC. TEORICA Max theor. Acc.	[Rad/sec ²]	5330
CARICO RADIALE MAX Max radial load	RI [N]	294
CARICO ASSIALE MAX Max axial load	AI [N]	88
PESO MOTORE Motor weight	G [Kg]	4.6
VENTILAZIONE Ventilation	NATURALE T.E.N.V.	
GRADO DI PROTEZIONE Class protection	IP	54

DATI ELETTRICI - Winding data

COST. DI TEMPO TERMICO Thermal time constant	Tt [min]	30
MAX VEL. SENZA CARICO Max no load speed	No max [rpm]	4000
MAX VEL. CON CARICO Max load speed	N max [rpm]	3000
CLASSE D'ISOLAMENTO Insulation class	F	
FATTORE DI SERVIZIO Duty cycle	S1	
FATTORE DI FORMA Form factor	FF	1
TEMP. AMBIENTE RIF. DATI Room temp. data refer.	T rif [°C]	40°

SERIE
Series

PENTA 5SL

W	RPM
300	3000
200	2000

CARATTERISTICHE GENERALI - Performance characteristics

TIPO MOTORE <i>Motor type</i>	5SL 30								5SL 20								
POTENZA RESA <i>Rated power</i>	Pnom [W]	300								200							
VELOCITA' NOMINALE <i>Rated speed</i>	Nnom [rpm]	3000								2000							
COPPIA NOMINALE <i>Rated torque</i>	Cnom [Nm]	0.96								0.96							
TENSIONE NOMINALE <i>Rated voltage</i>	Vnom [V]	180	90	60	48	36	24	12*	180	90	60	48	36	24	12*		
CORRENTE NOMINALE <i>Rated current</i>	Inom [A]	2.1	4.2	6.3	7.8	10.4	15.6		1.4	2.8	4.2	5.2	7	10.4			
COPPIA MASSIMA <i>Peak torque</i>	Cmax [Nm]	4.8	4.8	4.8	4.8	4.8	4.8		4.8	4.8	4.8	4.8	4.8	4.8			
CORRENTE MASSIMA <i>Peak current</i>	Imax [A]	10.5	21	31.5	39	52	78		7	14	21			52			
RESISTENZA ARMATURA <i>Armature resistance</i>	Rarm [Ohm]	5.3	1.41	0.67	0.4	0.29	0.16		12.5	2.5	1.41			0.29			
INDUTTANZA ARMATURA <i>Armature inductance</i>	La [mH]	18.5	4.1	2	1.2	0.7	0.32		42	9.46	4.1	2.74	1.45	0.7			
COST. TENSIONE <i>Voltage constant</i>	Ke [V/Krpm]	55.5	27	19	15	11.4	7.5		84.5	40	27	21		11.4			
COST. TEMPO ELET. <i>Elect. time constant</i>	Te [ms]	3.5	3.13	3	3	2.4	2		3.4	3.8	3.13			2.4			
COST. TEMPO MECC. <i>Mech. time constant</i>	Tm [ms]	13	19	14	14	17	22		13	12	19			17			

* Solo per servizio intermittente - Only intermittent duty

DATI MECCANICI - Mechanical data

INERZIA ROTORE <i>Rotor inertia</i>	Jm [Kgm ²]	0.0007
MAX ACC. TEORICA <i>Max theor. Acc.</i>	[Rad/sec ²]	6850
CARICO RADIALE MAX <i>Max radial load</i>	RI [N]	343
CARICO ASSIALE MAX <i>Max axial load</i>	AI [N]	103
PESO MOTORE <i>Motor weight</i>	G [Kg]	5.3
VENTILAZIONE <i>Ventilation</i>	NATURALE T.E.N.V.	
GRADO DI PROTEZIONE <i>Class protection</i>	IP	54

DATI ELETTRICI - Winding data

COST. DI TEMPO TERMICO <i>Thermal time constant</i>	Tt [min]	35
MAX VEL. SENZA CARICO <i>Max no load speed</i>	No max [rpm]	4000
MAX VEL. CON CARICO <i>Max load speed</i>	N max [rpm]	3000
CLASSE D'ISOLAMENTO <i>Insulation class</i>	F	
FATTORE DI SERVIZIO <i>Duty cycle</i>	S1	
FATTORE DI FORMA <i>Form factor</i>	FF	1
TEMP. AMBIENTE RIF. DATI <i>Room temp. data refer.</i>	T rif [°C]	40°

SERIE
Series

PENTA 5M

W	RPM
360	3000
240	2000

CARATTERISTICHE GENERALI - Performance characteristics

TIPO MOTORE		5M 30								5M 20							
Motor type																	
POTENZA RESA	P _{nom}																
Rated power	[W]	360								240							
VELOCITA' NOMINALE	N _{nom}																
Rated speed	[rpm]	3000								2000							
COPPIA NOMINALE	C _{nom}																
Rated torque	[Nm]	1.15								1.15							
TENSIONE NOMINALE	V _{nom}	180	90	60	48	36	24*	12*	180	90	60	48	36	24	12*		
Rated voltage	[V]																
CORRENTE NOMINALE	I _{nom}	2.6	5	7.5	9.4	12.5			1.7	3.4	5	6.25	8.3	12.5			
Rated current	[A]																
COPPIA MASSIMA	C _{max}	5.75	5.75	5.75	5.75	5.75			5.75	5.75	5.75	5.75	5.75	5.75			
Peak torque	[Nm]																
CORRENTE MASSIMA	I _{max}	12.6	25	37.5	47	62.5			8.5	17	25			62.5			
Peak current	[A]																
RESISTENZA ARMATURA	R _{arm}	4.05	0.9	0.52	0.35	0.25			7.2	1.84	0.9			0.25			
Armature resistance	[Ohm]																
INDUTTANZA ARMATURA	L _a	14.3	3	1.43	1	0.56			27	6.8	3	2	1.2	0.56			
Armature inductance	[mH]																
COST. TENSIONE	K _e		27	19.5	15.5	11.5			87	40	27			11.5			
Voltage constant	[V/Krpm]																
COST. TEMPO ELET.	T _e		3.4	2.75	2.9	2.5			3.75	3.7	3.4			2.5			
Elect. time constant	[ms]																
COST. TEMPO MECC.	T _m		10	12	13	14			8	10	10			14			
Mech. time constant	[ms]																

* Solo per servizio intermittente - Only intermittent duty

DATI MECCANICI - Mechanical data

INERZIA ROTORE	J _m	0.0008
Rotor inertia	[Kgm ²]	
MAX ACC. TEORICA		7187
Max theor. Acc.	[Rad/sec ²]	
CARICO RADIALE MAX	R _I	343
Max radial load	[N]	
CARICO ASSIALE MAX	A _I	103
Max axial load	[N]	
PESO MOTORE	G	6.4
Motor weight	[Kg]	
VENTILAZIONE		NATURALE
Ventilation		T.E.N.V.
GRADO DI PROTEZIONE		54
Class protection	IP	

DATI ELETTRICI - Winding data

COST. DI TEMPO TERMICO	T _t	45
Thermal time constant	[min]	
MAX VEL. SENZA CARICO	No max	4000
Max no load speed	[rpm]	
MAX VEL. CON CARICO	N max	3000
Max load speed	[rpm]	
CLASSE D'ISOLAMENTO		F
Insulation class		
FATTORE DI SERVIZIO		S1
Duty cycle		
FATTORE DI FORMA		1
Form factor	FF	
TEMP. AMBIENTE RIF. DATI	T _{rif}	40°
Room temp. data refer.	[°C]	

SERIE
Series

PENTA 5L

W	RPM
500	3000
335	2000

CARATTERISTICHE GENERALI - Performance characteristics

TIPO MOTORE		5L 30						5L 20							
<i>Motor type</i>															
POTENZA RESA	P _{nom}														
<i>Rated power</i>	[W]	500						335							
VELOCITA' NOMINALE	N _{nom}														
<i>Rated speed</i>	[rpm]	3000						2000							
COPPIA NOMINALE	C _{nom}														
<i>Rated torque</i>	[Nm]	1.6						1.6							
TENSIONE NOMINALE	V _{nom}	180	90	60	48	36*	24*	12*	180	90	60	48	36	24*	12*
<i>Rated voltage</i>	[V]														
CORRENTE NOMINALE	I _{nom}														
<i>Rated current</i>	[A]	3.3	6.6	10.5	13				2.2	4.4	6.6	10			
COPPIA MASSIMA	C _{max}														
<i>Peak torque</i>	[Nm]	8	8	8	8				8	8	8	8			
CORRENTE MASSIMA	I _{max}														
<i>Peak current</i>	[A]	16.5	33	51.5	65				11	22	33				
RESISTENZA ARMATURA	R _{arm}														
<i>Armature resistance</i>	[Ohm]	2.62	0.86	1.42	0.16				5.4	1.1	0.86				
INDUTTANZA ARMATURA	L _a														
<i>Armature inductance</i>	[mH]	8.8	2.2	0.95	0.35				18.5	4.3	2.2	1.39			
COST. TENSIONE	K _e														
<i>Voltage constant</i>	[V/Krpm]	57	27.7	17.8	11.5				84	40	27.7	21.5			
COST. TEMPO ELET.	T _e														
<i>Elect. time constant</i>	[ms]	3.4	2.6	2.2					3.43	3.9	2.6				
COST. TEMPO MECC.	T _m														
<i>Mech. time constant</i>	[ms]	9	12	14					8	7	12				

* Solo per servizio intermittente - Only intermittent duty

DATI MECCANICI - Mechanical data

INERZIA ROTORE	J _m	
<i>Rotor inertia</i>	[Kgm ²]	0.001
MAX ACC. TEORICA		
<i>Max theor. Acc.</i>	[Rad/sec ²]	8000
CARICO RADIALE MAX	R _I	
<i>Max radial load</i>	[N]	343
CARICO ASSIALE MAX	A _I	
<i>Max axial load</i>	[N]	103
PESO MOTORE	G	
<i>Motor weight</i>	[Kg]	8
VENTILAZIONE		NATURALE
<i>Ventilation</i>		T.E.N.V.
GRADO DI PROTEZIONE		
<i>Class protection</i>	IP	54

DATI ELETTRICI - Winding data

COST. DI TEMPO TERMICO	T _t	
<i>Thermal time constant</i>	[min]	55
MAX VEL. SENZA CARICO	No max	
<i>Max no load speed</i>	[rpm]	4000
MAX VEL. CON CARICO	N max	
<i>Max load speed</i>	[rpm]	3000
CLASSE D'ISOLAMENTO		
<i>Insulation class</i>		F
FATTORE DI SERVIZIO		
<i>Duty cycle</i>		S1
FATTORE DI FORMA		
<i>Form factor</i>	FF	1
TEMP. AMBIENTE RIF. DATI	T _{rif}	
<i>Room temp. data refer.</i>	[°C]	40°

PENTA 5

MOTORI C.C.

D.C. MOTORS



DIMENSIONI (mm) DIMENSIONS (mm)

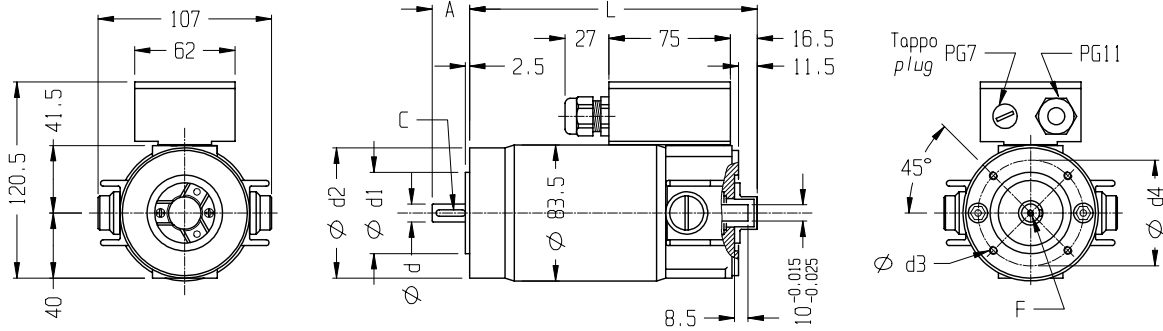

Type	X	XS		S		SL		M		L	
Size	B14/56	B14/56	B14/63	B14/56	B14/63	B14/63	B14/71	B14/63	B14/71	B14/63	B14/71
A	20	20	23	20	23	23	30	23	30	23	30
L	144.5	177.5		212.5		229		267.5		322.5	
d(h7)	9	9	11	9	11	11	14	11	14	11	14
F	-	-	M4	-	M4	M4	M5	M4	M5	M4	M5
C	3x3x15	3x3x15	4x4x18	3x3x15	4x4x18	4x4x18	5x5x25	4x4x18	5x5x25	4x4x18	5x5x25
d1(h7)	50	50	60	50	60	60	70	60	70	60	70
d2	80	80	90	80	90	90	105	90	105	90	105
d3	M5	M5	M5	M5	M5	M5	M6	M5	M6	M5	M6
d4	65	65	75	65	75	75	85	75	85	75	85

FLANGIA B5

B5 FLANGE

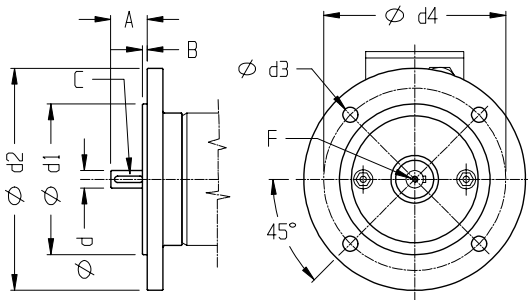

Size	A	B	C	d(h7)	d1(h7)	d2	d3	d4	F
56	20	3	3x3x15	9	80	120	8.5	100	-
63	23	3	4x4x18	11	95	140	9.5	115	M4
71	30	3.5	5x5x25	14	110	160	9.5	130	M5

FLANGIA B14

B14 FLANGE

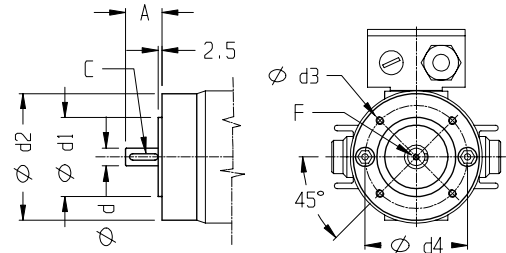

Size	A	C	d(h7)	d1(h7)	d2	d3	d4	F
56	20	3x3x15	9	50	80	M5	65	-
63	23	4x4x18	11	60	90	M5	75	M4
71	30	5x5x25	14	70	105	M6	85	M5

CONNETTORE

CONNECTOR

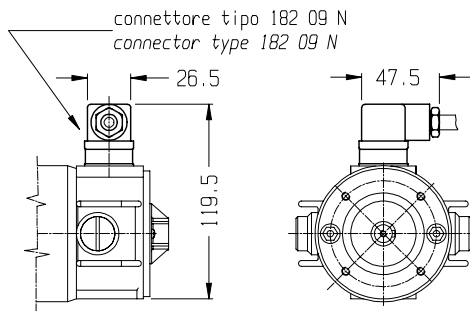

CAVO

FLYING LEADS

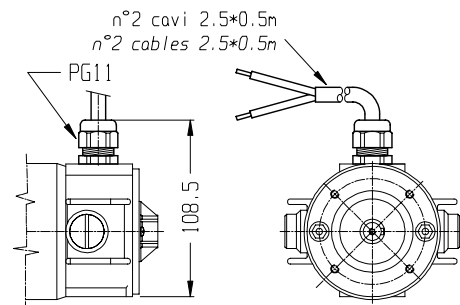

OPTIONALS

FLANGIA B3-B14/56

B3-B14/56 FLANGE

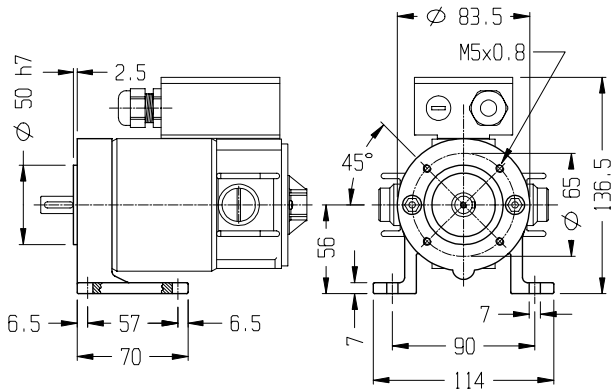

PIEDE A FASCIA

FOOT BAND TYPE

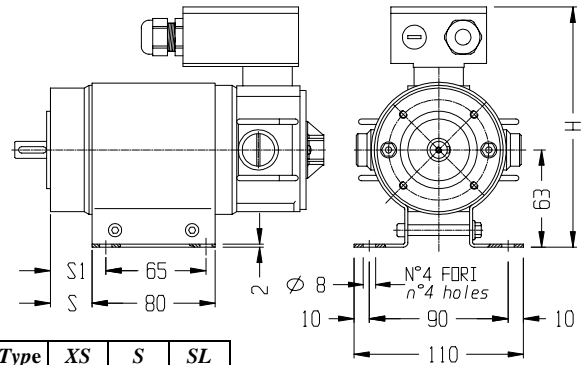

Type	XS	S	SL
H	155.5	143.5	143.5
S	27	27	27
SI	36	36	36

PASSACAVO

CABLE GLAND

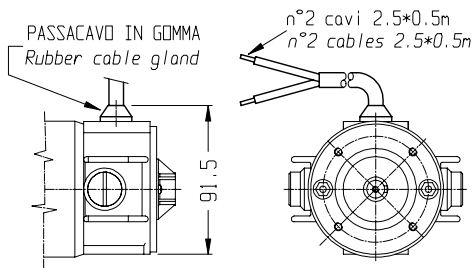

PRED. ENCODER

ENC. PREARRANGEMENT

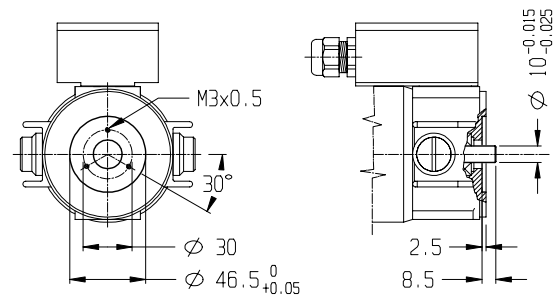

ENCODER EH53

ENCODER EH53

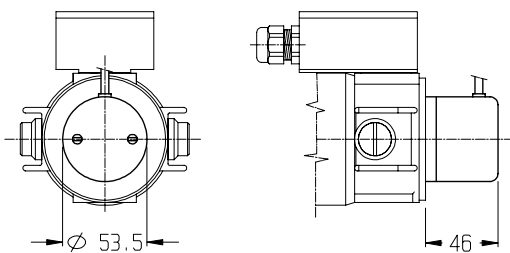

ENCODER EH38

ENCODER EH38

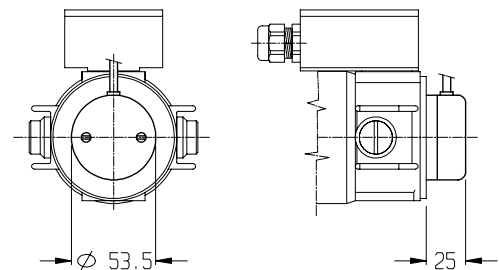

PENTA 5

MOTORI C.C.

D.C. MOTORS



OPTIONALS

DISTANZ. ENC. N°1 *ENCODER SPACER N°1*

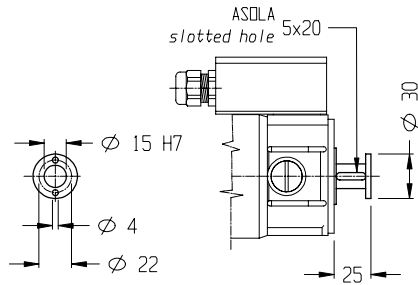

DISTANZ. ENC. N°2 *ENCODER SPACER N°2*

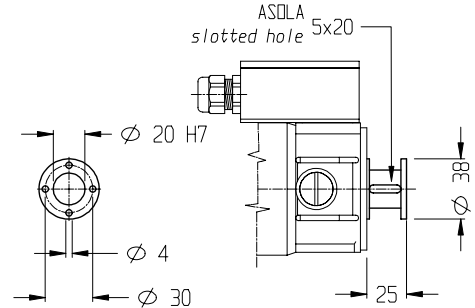

DISTANZ. ENC. N°3 *ENCODER SPACER N°3*

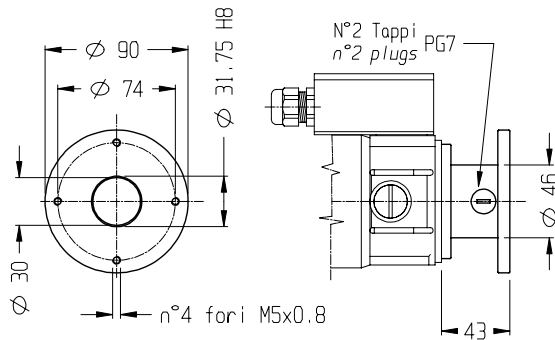

DIN. TACHIMETRICA *TACHO GENERATOR*

PREDISPOSTO ENCODER *ENCODER PREARRANGEMENT*

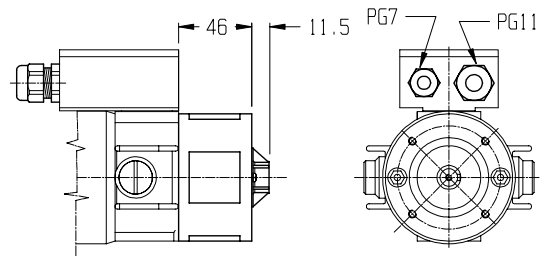

COSTANTE DI TENSIONE <i>VOLTAGE CONSTANT</i>	10±5% V/KRPM	CORRENTE NOMINALE <i>RATED CURRENT</i>	2 mA
VELOCITA' MASSIMA <i>MAX SPEED</i>	9000 RPM	CORRENTE MASSIMA <i>MAX CURRENT</i>	8 mA

FRENO 1,7 Nm

BRAKE 1,7 Nm

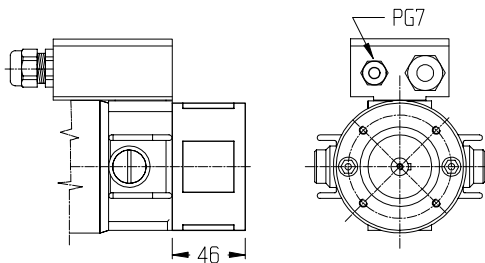

COPPIA STATICA <i>STATIC TORQUE</i>	1,7 Nm	CORRENTE <i>CURRENT</i>	0.46-0.058 A
TENSIONE DI ALIMEN. <i>POWER SUPPLY VOLTAGE</i>	24-190 V.c.c.	POTENZA ASSORBITA <i>INPUT POWER</i>	11 W

FRENO 1,7 Nm + DIN. TACHO GENERATOR + TACHIMETRICA *TACHO GENERATOR + BRAKE 1,7 Nm*

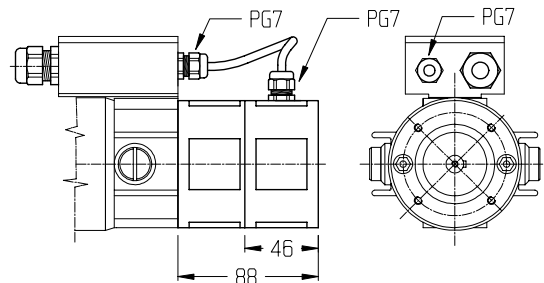

	FRENO <i>BRAKE</i>	DINAMO T. <i>TACHO G.</i>
COPPIA STATICA <i>STATIC TORQUE</i>	1,7 Nm	COSTANTE DI TENSIONE <i>VOLTAGE CONSTANT</i>
TENSIONE DI ALIMEN. <i>POWER SUPPLY VOLTAGE</i>	24-190 V.c.c.	VELOCITA' MASSIMA <i>MAX SPEED</i>
CORRENTE <i>CURRENT</i>	0.46-0.058 A	CORRENTE NOMINALE <i>RATED CURRENT</i>
POTENZA ASSORBITA <i>INPUT POWER</i>	11 W	CORRENTE MASSIMA <i>MAX CURRENT</i>

PENTA 5

MOTORI C.C.

D.C. MOTORS



OPTIONALS

FRENO 4 Nm

BRAKE 4 Nm

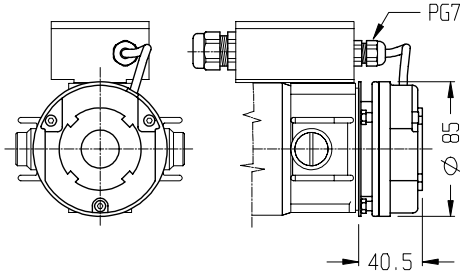

COPPIA STATICA <i>STATIC TORQUE</i>	4 Nm	CORRENTE <i>CURRENT</i>	0.83-0.109 A
TENSIONE DI ALIMEN. <i>POWER SUPPLY VOLTAGE</i>	24-190 V.c.c.	POTENZA ASSORBITA <i>INPUT POWER</i>	20 W

FRENO 4 Nm + DIN. TACHIMETRICA

*TACHO GENERATOR +
BRAKE 4 Nm*

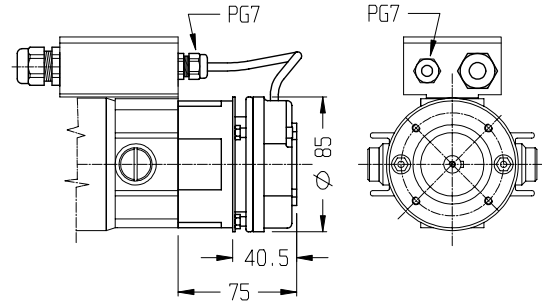

FRENO	BRAKE	DINAMO T.	TACHO G.
COPPIA STATICA <i>STATIC TORQUE</i>	4 Nm	COSTANTE DI TENSIONE <i>VOLTAGE CONSTANT</i>	10±5% V/KRPM
TENSIONE DI ALIMEN. <i>POWER SUPPLY VOLTAGE</i>	24-190 V.c.c.	VELOCITA' MASSIMA <i>MAX SPEED</i>	9000 RPM
CORRENTE <i>CURRENT</i>	0.83-0.109 A	CORRENTE NOMINALE <i>RATED CURRENT</i>	2 mA
POTENZA ASSORBITA <i>INPUT POWER</i>	20 W	CORRENTE MASSIMA <i>MAX CURRENT</i>	8 mA

MOTORI IN CORRENTE CONTINUA

D.C. MOTORS



SERIE
Series

PENTA

5XA

W	RPM
150	3000
100	2000

CARATTERISTICHE GENERALI - Performance characteristics

TIPO MOTORE		5XA 30								5XA 20							
<i>Motor type</i>																	
POTENZA RESA	P _{nom}																
<i>Rated power</i>	[W]	150								100							
VELOCITA' NOMINALE	N _{nom}																
<i>Rated speed</i>	[rpm]	3000								2000							
COPPIA NOMINALE	C _{nom}																
<i>Rated torque</i>	[Nm]	0.48								0.48							
TENSIONE NOMINALE	V _{nom}																
<i>Rated voltage</i>	[V]	180	90	60	48	36	24	12	180	90	60	48	36	24	12		
CORRENTE NOMINALE	I _{nom}																
<i>Rated current</i>	[A]	1.1		3.3	4	5.54	8.33	16	0.74	1.54	2.2	2.8		5.5	11		
COPPIA MASSIMA	C _{max}																
<i>Peak torque</i>	[Nm]	2.4		2.4	2.4	2.4	2.4	2.4	2.4	2.4	2.4	2.4		2.4	2.4		
CORRENTE MASSIMA	I _{max}																
<i>Peak current</i>	[A]	5.5		16.7	20	27.7	41.7	80	3.7	7.7	11	14		27.5	55		
RESISTENZA ARMATURA	R _{arm}																
<i>Armature resistance</i>	[Ohm]	16.1		1.8	1.1	0.74	0.45	0.1	44.1	10.9	4	2.7		0.53	0.17		
INDUTTANZA ARMATURA	L _a																
<i>Armature inductance</i>	[mH]	51.5		5.4	3	1.8	0.9	0.18	145.5	35.4	12.6	8		1.32	0.34		
COST. TENSIONE	K _e																
<i>Voltage constant</i>	[V/Krpm]	50		16.5	13.5	10	6.5	3.5	70	35.5	24	19		8	4.8		
COST. TEMPO ELET.	T _e																
<i>Elect. time constant</i>	[ms]	3.2		3	2.7	2.4	2.2	1.8	3.3	3.25	3.15	3		2.5	2		
COST. TEMPO MECC.	T _m																
<i>Mech. time constant</i>	[ms]	13		13	12	14	19	16	18	17	14	15		13	12		

* Solo per servizio intermittente - Only intermittent duty

DATI MECCANICI - Mechanical data

INERZIA ROTORE	J _m	
<i>Rotor inertia</i>	[Kgm ²]	0.00018
MAX ACC. TEORICA		
<i>Max theor. Acc.</i>	[Rad/sec ²]	13300
CARICO RADIALE MAX	R _I	
<i>Max radial load</i>	[N]	294
CARICO ASSIALE MAX	A _I	
<i>Max axial load</i>	[N]	88
PESO MOTORE	G	
<i>Motor weight</i>	[Kg]	3.6
VENTILAZIONE	AUTOVENTILATO	
<i>Ventilation</i>	T.E.N.V.	
GRADO DI PROTEZIONE		
<i>Class protection</i>	IP	54

DATI ELETTRICI - Winding data

COST. DI TEMPO TERMICO	T _t	
<i>Thermal time constant</i>	[min]	30
MAX VEL. SENZA CARICO	No max	
<i>Max no load speed</i>	[rpm]	4000
MAX VEL. CON CARICO	N max	
<i>Max load speed</i>	[rpm]	3000
CLASSE D'ISOLAMENTO		
<i>Insulation class</i>		F
FATTORE DI SERVIZIO		
<i>Duty cycle</i>		S1
FATTORE DI FORMA		
<i>Form factor</i>	FF	1
TEMP. AMBIENTE RIF. DATI	T _{rif}	
<i>Room temp. data refer.</i>	[°C]	40°

SERIE
Series

PENTA

5XSA

W	RPM
235	3000
155	2000

CARATTERISTICHE GENERALI - Performance characteristics

TIPO MOTORE <i>Motor type</i>		5XSA 30							5XSA 20						
POTENZA RESA <i>Rated power</i>	Pnom [W]	235							155						
VELOCITA' NOMINALE <i>Rated speed</i>	Nnom [rpm]	3000							2000						
COPPIA NOMINALE <i>Rated torque</i>	Cnom [Nm]	0.75							0.75						
TENSIONE NOMINALE <i>Rated voltage</i>	Vnom [V]	180	90	60	48	36	24	12*	180	90	60	48	36	24	12*
CORRENTE NOMINALE <i>Rated current</i>	Inom [A]	1.7	3.4	5	6.25	8.3	12.5		1.14	2.28	3.4	4.3	5.7	8.54	
COPPIA MASSIMA <i>Peak torque</i>	Cmax [Nm]	3.75	3.75	3.75	3.75	3.75	3.75		3.75	3.75	3.75	3.75	3.75	3.75	
CORRENTE MASSIMA <i>Peak current</i>	Imax [A]	8.5		25	31	41.5	62.5		5.7	11.4	17	21.5		42.7	
RESISTENZA ARMATURA <i>Armature resistance</i>	Rarm [Ohm]	13.65		1.5	0.9	0.58	0.38		30.6	7.6	3.3	2.25		0.41	
INDUTTANZA ARMATURA <i>Armature inductance</i>	La [mH]	47	11.5	4.5	2.5	1.6	0.825		107	26	10.4	6.45	4	1.45	
COST. TENSIONE <i>Voltage constant</i>	Ke [V/Krpm]	50		16.5	13.5	10	6.5		70	35.5	24	19		8	
COST. TEMPO ELET. <i>Elect. time constant</i>	Te [ms]	3.45		3	2.8	2.75	2.17		3.5	3.4	3.12	2.9		2.3	
COST. TEMPO MECC. <i>Mech. time constant</i>	Tm [ms]	18		18	16	21	28		20	20	19	20		21	

* Solo per servizio intermittente - Only intermittent duty

DATI MECCANICI - Mechanical data

INERZIA ROTORE <i>Rotor inertia</i>	Jm [Kgm ²]	0.0003
MAX ACC. TEORICA <i>Max theor. Acc.</i>	[Rad/sec ²]	12500
CARICO RADIALE MAX <i>Max radial load</i>	RI [N]	294
CARICO ASSIALE MAX <i>Max axial load</i>	AI [N]	88
PESO MOTORE <i>Motor weight</i>	G [Kg]	4.2
VENTILAZIONE <i>Ventilation</i>	AUTOVENTILATO T.E.N.V.	
GRADO DI PROTEZIONE <i>Class protection</i>	IP	54

DATI ELETTRICI - Winding data

COST. DI TEMPO TERMICO <i>Thermal time constant</i>	Tt [min]	35
MAX VEL. SENZA CARICO <i>Max no load speed</i>	No max [rpm]	4000
MAX VEL. CON CARICO <i>Max load speed</i>	N max [rpm]	3000
CLASSE D'ISOLAMENTO <i>Insulation class</i>		F
FATTORE DI SERVIZIO <i>Duty cycle</i>		S1
FATTORE DI FORMA <i>Form factor</i>	FF	1
TEMP. AMBIENTE RIF. DATI <i>Room temp. data refer.</i>	T rif [°C]	40°

MOTORI IN CORRENTE CONTINUA

D.C. MOTORS



SERIE
Series

PENTA 5SA

W	RPM
300	3000
200	2000

CARATTERISTICHE GENERALI - Performance characteristics

TIPO MOTORE <i>Motor type</i>		5SA 30								5SA 20							
POTENZA RESA <i>Rated power</i>	P _{nom} [W]	300								200							
VELOCITA' NOMINALE <i>Rated speed</i>	N _{nom} [rpm]	3000								2000							
COPPIA NOMINALE <i>Rated torque</i>	C _{nom} [Nm]	0.96								0.96							
TENSIONE NOMINALE <i>Rated voltage</i>	V _{nom} [V]	180	90	60	48	36	24	12*	180	90	60	48	36	24	12*		
CORRENTE NOMINALE <i>Rated current</i>	I _{nom} [A]	2.1	4.2	6.3	7.8	10.4	15.6		1.4	2.8	4.2	5.2	7	10.4			
COPPIA MASSIMA <i>Peak torque</i>	C _{max} [Nm]	4.8	4.8	4.8	4.8	4.8	4.8		4.8	4.8	4.8	4.8	4.8	4.8			
CORRENTE MASSIMA <i>Peak current</i>	I _{max} [A]	10.5		31.5	39	52	78		7	14	21	26		52			
RESISTENZA ARMATURA <i>Armature resistance</i>	R _{arm} [Ohm]	5.9		0.76	0.49	0.32	0.18		11.7	2.9	1.6	1.1		0.235			
INDUTTANZA ARMATURA <i>Armature inductance</i>	L _a [mH]	19		2.2	1.32	0.8	0.38		36	9	4.9	3		0.52			
COST. TENSIONE <i>Voltage constant</i>	K _e [V/Krpm]	50		16.5	13.5	10	7		74	37	24	19		8.5			
COST. TEMPO ELET. <i>Elect. time constant</i>	T _e [ms]	3.3		2.9	2.7	2.5	2.1		3.1	3.1	3.1	2.7		2.2			
COST. TEMPO MECC. <i>Mech. time constant</i>	T _m [ms]	15		18	17	21	24		14	14	15	20		21			

* Solo per servizio intermittente - Only intermittent duty

DATI MECCANICI - Mechanical data

INERZIA ROTORE <i>Rotor inertia</i>	J _m [Kgm ²]	0.0006
MAX ACC. TEORICA <i>Max theor. Acc.</i>	[Rad/sec ²]	8000
CARICO RADIALE MAX <i>Max radial load</i>	R _I [N]	294
CARICO ASSIALE MAX <i>Max axial load</i>	A _I [N]	88
PESO MOTORE <i>Motor weight</i>	G [Kg]	5.5
VENTILAZIONE <i>Ventilation</i>	AUTOVENTILATO T.E.N.V.	
GRADO DI PROTEZIONE <i>Class protection</i>	IP	54

DATI ELETTRICI - Winding data

COST. DI TEMPO TERMICO <i>Thermal time constant</i>	T _t [min]	40
MAX VEL. SENZA CARICO <i>Max no load speed</i>	No max [rpm]	4000
MAX VEL. CON CARICO <i>Max load speed</i>	N max [rpm]	3000
CLASSE D'ISOLAMENTO <i>Insulation class</i>		F
FATTORE DI SERVIZIO <i>Duty cycle</i>		S1
FATTORE DI FORMA <i>Form factor</i>	FF	1
TEMP. AMBIENTE RIF. DATI <i>Room temp. data refer.</i>	T _{rif} [°C]	40°

SERIE
Series

PENTA

5SLA

W	RPM
440	3000
290	2000

CARATTERISTICHE GENERALI - Performance characteristics

TIPO MOTORE <i>Motor type</i>		5SLA 30								5SLA 20							
POTENZA RESA <i>Rated power</i>	Pnom [W]	440								290							
VELOCITA' NOMINALE <i>Rated speed</i>	Nnom [rpm]	3000								2000							
COPPIA NOMINALE <i>Rated torque</i>	Cnom [Nm]	1.4								1.4							
TENSIONE NOMINALE <i>Rated voltage</i>	Vnom [V]	180	90	60	48	36	24*	12*	180	90	60	48	36	24	12*		
CORRENTE NOMINALE <i>Rated current</i>	Inom [A]	3	6	9	11.3	15			2	4	6	7.5	10	15			
COPPIA MASSIMA <i>Peak torque</i>	Cmax [Nm]	7	7	7	7	7			7	7	7	7	7	7			
CORRENTE MASSIMA <i>Peak current</i>	Imax [A]	15	30	45	56.5	75			10	20	30	37.5	50	75			
RESISTENZA ARMATURA <i>Armature resistance</i>	Rarm [Ohm]	4.86	1.37	0.54	0.45	0.27			11	3.05	1.37	0.88	0.45	0.25			
INDUTTANZA ARMATURA <i>Armature inductance</i>	La [mH]	17	4.45	1.84	1.4	0.62			37.8	10.3	4.45	2.5	1.4	0.57			
COST. TENSIONE <i>Voltage constant</i>	Ke [V/Krpm]	53	26	17	14.5	10.5			78	39	26	20.5	14.5	9			
COST. TEMPO ELET. <i>Elect. time constant</i>	Te [ms]	3.5	3.3	3.4	3.1	2.3			3.45	3.4	3.3	2.84	3.1	2.3			
COST. TEMPO MECC. <i>Mech. time constant</i>	Tm [ms]	13	14	14	16	18			14	15	14	15	16	25			

* Solo per servizio intermittente - Only intermittent duty

DATI MECCANICI - Mechanical data

INERZIA ROTORE <i>Rotor inertia</i>	Jm [Kgm ²]	0.0007
MAX ACC. TEORICA <i>Max theor. Acc.</i>	[Rad/sec ²]	10000
CARICO RADIALE MAX <i>Max radial load</i>	RI [N]	343
CARICO ASSIALE MAX <i>Max axial load</i>	AI [N]	103
PESO MOTORE <i>Motor weight</i>	G [Kg]	6.25
VENTILAZIONE <i>Ventilation</i>	AUTOVENTILATO T.E.N.V.	
GRADO DI PROTEZIONE <i>Class protection</i>	IP	54

DATI ELETTRICI - Winding data

COST. DI TEMPO TERMICO <i>Thermal time constant</i>	Tt [min]	40
MAX VEL. SENZA CARICO <i>Max no load speed</i>	No max [rpm]	4000
MAX VEL. CON CARICO <i>Max load speed</i>	N max [rpm]	3000
CLASSE D'ISOLAMENTO <i>Insulation class</i>		F
FATTORE DI SERVIZIO <i>Duty cycle</i>		S1
FATTORE DI FORMA <i>Form factor</i>	FF	1
TEMP. AMBIENTE RIF. DATI <i>Room temp. data refer.</i>	T rif [°C]	40°

MOTORI IN CORRENTE CONTINUA

D.C. MOTORS



SERIE
Series

PENTA

5MA

W	RPM
565	3000
375	2000

CARATTERISTICHE GENERALI - Performance characteristics

TIPO MOTORE		5MA 30						5MA 20							
Motor type															
POTENZA RESA	P _{nom}														
Rated power	[W]	565						375							
VELOCITA' NOMINALE	N _{nom}														
Rated speed	[rpm]	3000						2000							
COPPIA NOMINALE	C _{nom}														
Rated torque	[Nm]	1.8						1.8							
TENSIONE NOMINALE	V _{nom}														
Rated voltage	[V]	180	90	60	48	36*	24*	12*	180	90	60	48	36	24*	12*
CORRENTE NOMINALE	I _{nom}														
Rated current	[A]	3.7	7.4	11	13.8				2.5	5	7.4	9.3	13.8		
COPPIA MASSIMA	C _{max}														
Peak torque	[Nm]	9	9	9	9				9	9	9	9	9		
CORRENTE MASSIMA	I _{max}														
Peak current	[A]	18.5	37	55	69				12.5	25	37	46.5			
RESISTENZA ARMATURA	R _{arm}														
Armature resistance	[Ohm]	3.65	0.93	0.49	0.33				6.8	2.2	0.93	0.55			
INDUTTANZA ARMATURA	L _a														
Armature inductance	[mH]	12	2.8	1.6	0.85				23	7	2.8	1.5	1.08		
COST. TENSIONE	K _e														
Voltage constant	[V/Krpm]	54.5	26	18	14.5				82	41.5	26	22	16		
COST. TEMPO ELET.	T _e														
Elect. time constant	[ms]	3.3	3	3.2	2.6				3.4	3.2	3	2.7			
COST. TEMPO MECC.	T _m														
Mech. time constant	[ms]	11	12	13	13				9	11	12	10			

* Solo per servizio intermittente - Only intermittent duty

DATI MECCANICI - Mechanical data

INERZIA ROTORE	J _m	
Rotor inertia	[Kgm ²]	0.0008
MAX ACC. TEORICA		
Max theor. Acc.	[Rad/sec ²]	11250
CARICO RADIALE MAX	R _I	
Max radial load	[N]	343
CARICO ASSIALE MAX	A _I	
Max axial load	[N]	103
PESO MOTORE	G	
Motor weight	[Kg]	7.5
VENTILAZIONE	AUTOVENTILATO	
Ventilation	T.E.N.V.	
GRADO DI PROTEZIONE		
Class protection	IP	54

DATI ELETTRICI - Winding data

COST. DI TEMPO TERMICO	T _t	
Thermal time constant	[min]	40
MAX VEL. SENZA CARICO	No max	
Max no load speed	[rpm]	4000
MAX VEL. CON CARICO	N max	
Max load speed	[rpm]	3000
CLASSE D'ISOLAMENTO		
Insulation class		F
FATTORE DI SERVIZIO		
Duty cycle		S1
FATTORE DI FORMA		
Form factor	FF	1
TEMP. AMBIENTE RIF. DATI	T _{rif}	
Room temp. data refer.	[°C]	40°

PENTA5A

MOTORI C.C.

D.C. MOTORS



DIMENSIONI (mm) DIMENSIONS (mm)

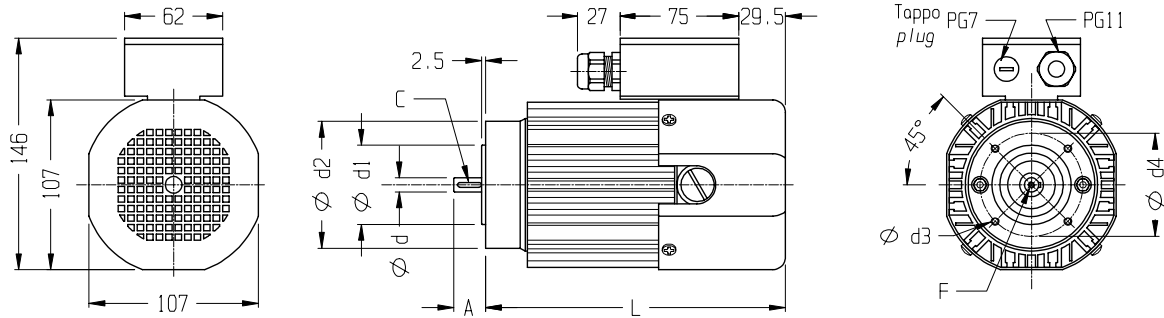

Type	X	XS		S		SL		M	
Size	B14/56	B14/56	B14/63	B14/56	B14/63	B14/63	B14/71	B14/63	B14/71
A	20	20	23	20	23	23	30	23	30
L	156.5	189.5		224.5		241		279.5	
d(h7)	9	9	11	9	11	11	14	11	14
F	-	-	M4	-	M4	M4	M5	M4	M5
C	3x3x15	3x3x15	4x4x18	3x3x15	4x4x18	4x4x18	5x5x25	4x4x18	5x5x25
d1(h7)	50	50	60	50	60	60	70	60	70
d2	80	80	90	80	90	90	105	90	105
d3	M5	M5	M5	M5	M5	M5	M6	M5	M6
d4	65	65	75	65	75	75	85	75	85

FLANGIA B5

B5 FLANGE

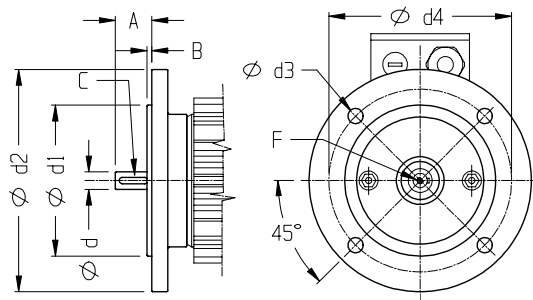

Size	A	B	C	d(h7)	d1(h7)	d2	d3	d4	F
56	20	3	3x3x15	9	80	120	8.5	100	-
63	23	3	4x4x18	11	95	140	9.5	115	M4
71	30	3.5	5x5x25	14	110	160	9.5	130	M5

FLANGIA B14

B14 FLANGE

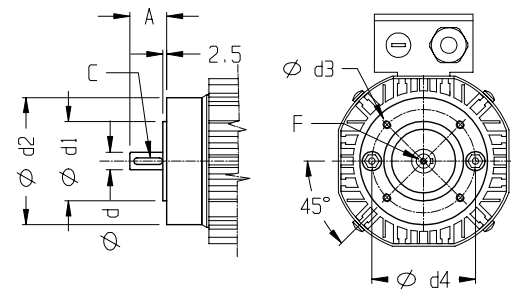

Size	A	C	d(h7)	d1(h7)	d2	d3	d4	F
56	20	3x3x15	9	50	80	M5	65	-
63	23	4x4x18	11	60	90	M5	75	M4
71	30	5x5x25	14	70	105	M6	85	M5

CAVO

FLYING LEADS

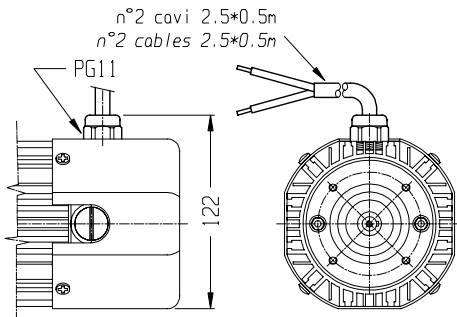

CONNETTORE

CONNECTOR

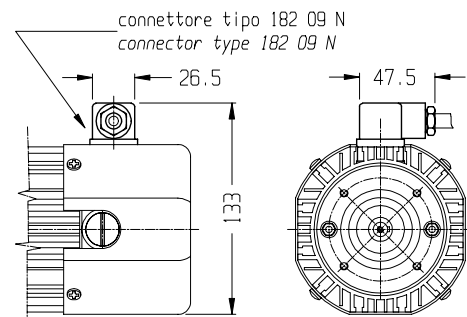

PENTA 5A

MOTORI C.C.

D.C. MOTORS



OPTIONALS

PIEDE B3

B3 FOOT

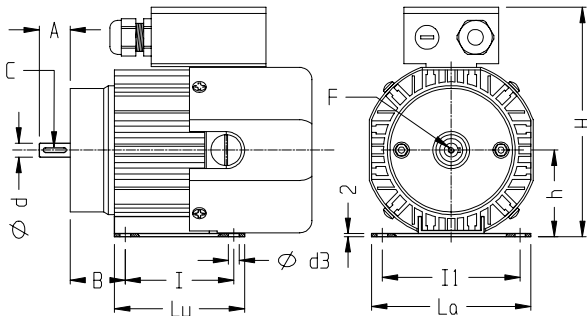

Type	XS			S		SL			M	
Size	B3/56	B3/56	B3/63	B3/56	B3/63	B3/63	B3/71	B3/63	B3/71	
A	20	20	23	20	23	23	30	23	30	
d(h7)	9	9	11	9	11	11	14	11	14	
Lu	85	85	95	85	95	95	104	95	104	
La	104	104	114	104	114	114	126	114	126	
F	-	-	M4	-	M4	M4	M5	M4	M5	
C	3x3x1	3x3x1	4x4x1	3x3x1	4x4x1	4x4x1	5x5x2	4x4x1	5x5x2	
B	36	36	40	36	40	40	45	40	45	
I	71	71	80	71	80	80	90	80	90	
II	90	90	100	90	100	100	112	100	112	
H	148.5	148.5	155.5	148.5	155.5	155.5	163.5	155.5	163.5	
h	56	56	63	56	63	63	71	63	71	
d3	7	7	9	7	9	9	9	9	9	

FLANGIA B3

B3 FLANGE

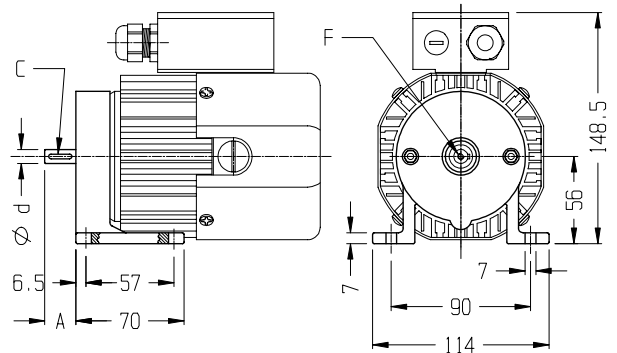

Type	X	XS		S		SL		M	
A	20	20	23	20	23	23	30	23	30
d(h7)	9	9	11	9	11	11	14	11	14
F	-	-	M4	-	M4	M4	M5	M4	M5
C	3x3x1	3x3x1	4x4x1	3x3x1	4x4x1	4x4x1	5x5x2	4x4x1	5x5x2

DIN. TACHIMETRICA

TACHO GENERATOR

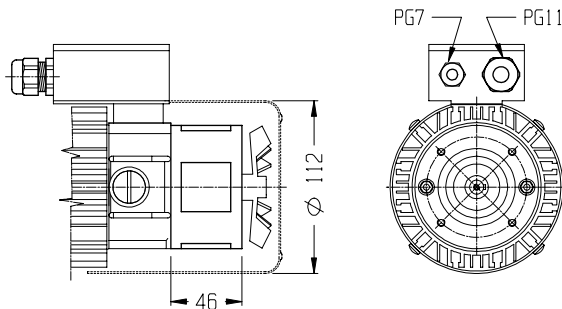

LA LUNGHEZZA TOTALE DEL MOTORE AUMENTA DI 42 mm
THE TOTAL LENGTH OF THE MOTOR INCREASES OF 42 mm

COSTANTE DI TENSIONE VOLTAGE CONSTANT	10±5% V/KRPM	CORRENTE NOMINALE RATED CURRENT	2 mA
VELOCITA' MASSIMA MAX SPEED	9000 RPM	CORRENTE MASSIMA MAX CURRENT	8 mA

FRENO 1,7 Nm

BRAKE 1,7 Nm

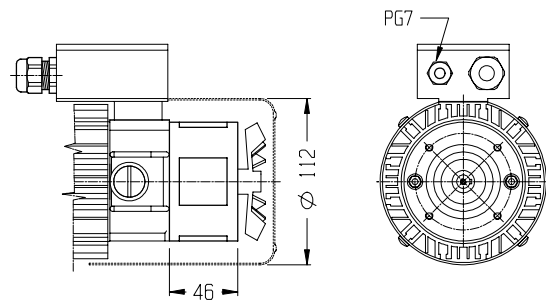

LA LUNGHEZZA TOTALE DEL MOTORE AUMENTA DI 42 mm
THE TOTAL LENGTH OF THE MOTOR INCREASES OF 42 mm

COPPIA STATICA STATIC TORQUE	1,7 Nm	CORRENTE CURRENT	0.46-0.058 A
TENSIONE DI ALIMEN. POWER SUPPLY VOLTAGE	24-190 V.c.c.	POTENZA ASSORBITA INPUT POWER	11 W

FRENO 4 Nm

BRAKE 4 Nm

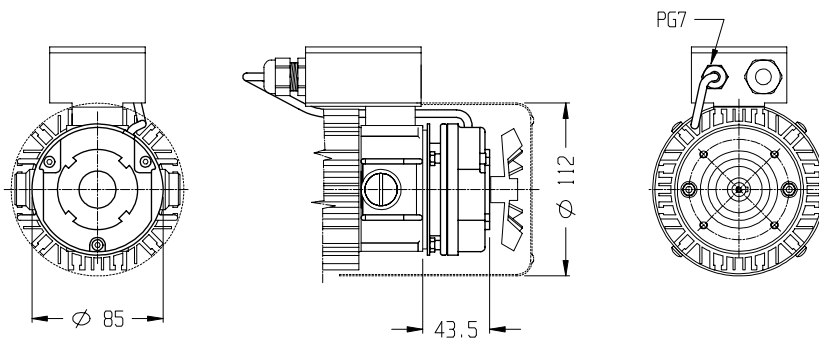

LA LUNGHEZZA TOTALE DEL MOTORE AUMENTA DI 42 mm
THE TOTAL LENGTH OF THE MOTOR INCREASES OF 42 mm

COPPIA STATICA STATIC TORQUE	4 Nm
TENSIONE DI ALIMEN. POWER SUPPLY VOLTAGE	24-190 V.c.c.
CORRENTE CURRENT	0.83-0.109 A
POTENZA ASSORBITA INPUT POWER	20 W

SERIE
Series

PENTA 7SA

W	RPM
750	3000
500	2000

CARATTERISTICHE GENERALI - Performance characteristics

TIPO MOTORE <i>Motor type</i>		7SA 30							7SA 20						
POTENZA RESA <i>Rated power</i>	Pnom [W]	750							500						
VELOCITA' NOMINALE <i>Rated speed</i>	Nnom [rpm]	3000							2000						
COPPIA NOMINALE <i>Rated torque</i>	Cnom [Nm]	2.4							2.4						
TENSIONE NOMINALE <i>Rated voltage</i>	Vnom [V]	180	90	60*	48*	36*	24*		180	90	60	48	36*	24*	12*
CORRENTE NOMINALE <i>Rated current</i>	Inom [A]	5.7	10.6						3.55	7	14	14			
COPPIA MASSIMA <i>Peak torque</i>	Cmax [Nm]	12	12						12	12	12	13.25			
CORRENTE MASSIMA <i>Peak current</i>	Imax [A]	28.5	53						17.75	35	10.7				
RESISTENZA ARMATURA <i>Armature resistance</i>	Rarm [Ohm]	2.35	0.71						5.55	1.44					
INDUTTANZA ARMATURA <i>Armature inductance</i>	La [mH]	13.9	4.6						35.4	9	2.77	1.61			
COST. TENSIONE <i>Voltage constant</i>	Ke [V/Krpm]	58	29.5						87	44	26.1	20.3			
COST. TEMPO ELET. <i>Elect. time constant</i>	Te [ms]	5.9	6.5						6.4	6.3					
COST. TEMPO MECC. <i>Mech. time constant</i>	Tm [ms]	14	16						14	14					

* Solo per servizio intermittente - Only intermittent duty

DATI MECCANICI - Mechanical data

INERZIA ROTORE <i>Rotor inertia</i>	Jm [Kgm ²]	0.0018
MAX ACC. TEORICA <i>Max theor. Acc.</i>	[Rad/sec ²]	6600
CARICO RADIALE MAX <i>Max radial load</i>	RI [N]	588
CARICO ASSIALE MAX <i>Max axial load</i>	AI [N]	176
PESO MOTORE <i>Motor weight</i>	G [Kg]	9.4
VENTILAZIONE <i>Ventilation</i>	AUTOVENTILATO T.E.N.V.	
GRADO DI PROTEZIONE <i>Class protection</i>	IP	54

DATI ELETTRICI - Winding data

COST. DI TEMPO TERMICO <i>Thermal time constant</i>	Tt [min]	45
MAX VEL. SENZA CARICO <i>Max no load speed</i>	No max [rpm]	4000
MAX VEL. CON CARICO <i>Max load speed</i>	N max [rpm]	3000
CLASSE D'ISOLAMENTO <i>Insulation class</i>		F
FATTORE DI SERVIZIO <i>Duty cycle</i>		S1
FATTORE DI FORMA <i>Form factor</i>	FF	1
TEMP. AMBIENTE RIF. DATI <i>Room temp. data refer.</i>	T rif [°C]	40°

MOTORI IN CORRENTE CONTINUA

D.C. MOTORS



SERIE
Series

PENTA

7MA

W	RPM
1100	3000
750	2000

CARATTERISTICHE GENERALI - Performance characteristics

TIPO MOTORE		7MA 30						7MA 20					
Motor type													
POTENZA RESA	P _{nom}												
Rated power	[W]	1100						750					
VELOCITA' NOMINALE	N _{nom}												
Rated speed	[rpm]	3000						2000					
COPPIA NOMINALE	C _{nom}												
Rated torque	[Nm]	3.5						3.5					
TENSIONE NOMINALE	V _{nom}												
Rated voltage	[V]	180	90	60	48*	36*		180	90	60	48	36*	24*
CORRENTE NOMINALE	I _{nom}												
Rated current	[A]	7.3	14.6	22.9				5.5	11	16.5	23		
COPPIA MASSIMA	C _{max}												
Peak torque	[Nm]	17.5	17.5	17.5				17.5	17.5	17.5	17.5		
CORRENTE MASSIMA	I _{max}												
Peak current	[A]	36.5	73	114.5				27.5	55		114		
RESISTENZA ARMATURA	R _{arm}												
Armature resistance	[Ohm]	0.85	0.26	0.30				1.51	0.45	0.5	0.22		
INDUTTANZA ARMATURA	L _a												
Armature inductance	[mH]	3.15	0.95	0.28				6.8	1.65	1.6	0.22		
COST. TENSIONE	K _e												
Voltage constant	[V/Krpm]	57.7	30	19.2				84	40	44	19.5		
COST. TEMPO ELET.	T _e												
Elect. time constant	[ms]	3.7	4.3					4.6	3.7				
COST. TEMPO MECC.	T _m												
Mech. time constant	[ms]	8	7					6	9				

* Solo per servizio intermittente - Only intermittent duty

DATI MECCANICI - Mechanical data

INERZIA ROTORE	J _m	
Rotor inertia	[Kgm ²]	0.0028
MAX ACC. TEORICA		
Max theor. Acc.	[Rad/sec ²]	6250
CARICO RADIALE MAX	R _I	
Max radial load	[N]	588
CARICO ASSIALE MAX	A _I	
Max axial load	[N]	176
PESO MOTORE	G	
Motor weight	[Kg]	13.6
VENTILAZIONE	AUTOVENTILATO	
Ventilation	T.E.N.V.	
GRADO DI PROTEZIONE		
Class protection	IP	54

DATI ELETTRICI - Winding data

COST. DI TEMPO TERMICO	T _t	
Thermal time constant	[min]	55
MAX VEL. SENZA CARICO	No max	
Max no load speed	[rpm]	4000
MAX VEL. CON CARICO	N max	
Max load speed	[rpm]	3000
CLASSE D'ISOLAMENTO		
Insulation class		F
FATTORE DI SERVIZIO		
Duty cycle		S1
FATTORE DI FORMA		
Form factor	FF	1
TEMP. AMBIENTE RIF. DATI	T _{rif}	
Room temp. data refer.	[°C]	40°

MOTORI IN CORRENTE CONTINUA

D.C. MOTORS



SERIE
Series

PENTA 7LA

W	RPM
1500	3000
1100	2000

CARATTERISTICHE GENERALI - Performance characteristics

TIPO MOTORE <i>Motor type</i>	7LA 30							7LA 20							
POTENZA RESA <i>Rated power</i>	Pnom [W]	1500							1100						
VELOCITA' NOMINALE <i>Rated speed</i>	Nnom [rpm]	3000							2000						
COPPIA NOMINALE <i>Rated torque</i>	Cnom [Nm]	4.8							4.8						
TENSIONE NOMINALE <i>Rated voltage</i>	Vnom [V]	180	110	90	60*	48*	36*	180	110	90*	60*	48*	36*	24*	
CORRENTE NOMINALE <i>Rated current</i>	Inom [A]	9.8	15.5	19.6				6.8	11						
COPPIA MASSIMA <i>Peak torque</i>	Cmax [Nm]	24	24	24				24	24						
CORRENTE MASSIMA <i>Peak current</i>	Imax [A]	49	77.5	98.1				34	55						
RESISTENZA ARMATURA <i>Armature resistance</i>	Rarm [Ohm]	0.42	0.22	0.3				1.05	0.45						
INDUTTANZA ARMATURA <i>Armature inductance</i>	La [mH]	1.72	0.73	0.47				4.2	1.65						
COST. TENSIONE <i>Voltage constant</i>	Ke [V/Krpm]	57	35	28.5				84	53.5						
COST. TEMPO ELET. <i>Elect. time constant</i>	Te [ms]	4.1	4.1					4.15	4.1						
COST. TEMPO MECC. <i>Mech. time constant</i>	Tm [ms]	7	8					8	7						

* Solo per servizio intermittente - Only intermittent duty

DATI MECCANICI - Mechanical data

INERZIA ROTORE <i>Rotor inertia</i>	Jm [Kgm ²]	0.0051
MAX ACC. TEORICA <i>Max theor. Acc.</i>	[Rad/sec ²]	4705
CARICO RADIALE MAX <i>Max radial load</i>	Rl [N]	588
CARICO ASSIALE MAX <i>Max axial load</i>	Al [N]	176
PESO MOTORE <i>Motor weight</i>	G [Kg]	17
VENTILAZIONE <i>Ventilation</i>	AUTOVENTILATO T.E.N.V.	
GRADO DI PROTEZIONE <i>Class protection</i>	IP	54

DATI ELETTRICI - Winding data

COST. DI TEMPO TERMICO <i>Thermal time constant</i>	Tt [min]	65
MAX VEL. SENZA CARICO <i>Max no load speed</i>	No max [rpm]	4000
MAX VEL. CON CARICO <i>Max load speed</i>	N max [rpm]	3000
CLASSE D'ISOLAMENTO <i>Insulation class</i>		F
FATTORE DI SERVIZIO <i>Duty cycle</i>		S1
FATTORE DI FORMA <i>Form factor</i>	FF	1
TEMP. AMBIENTE RIF. DATI <i>Room temp. data refer.</i>	T rif [°C]	40°

PENTA7A

MOTORI C.C.

D.C. MOTORS



DIMENSIONI (mm) DIMENSIONS (mm)

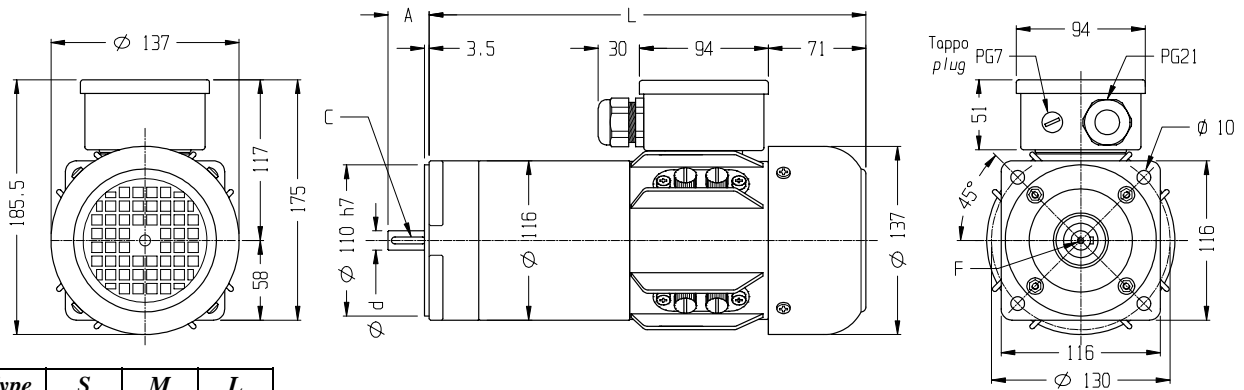

Type	S	M	L
A		40	
L	318	390	462
d(h7)	19		
F	M6		
C	6x6x30		

FLANGIA B5

B5 FLANGE

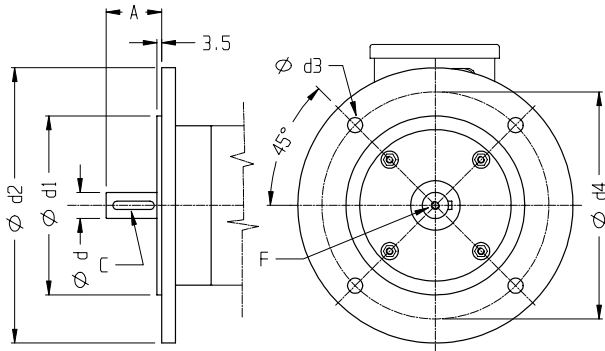

Size	A	C	d(h7)	d1(h7)	d2	d3	d4	F
71	30	5x5x25	14	110	160	9.5	130	M5
80	40	6x6x30	19	130	200	11	165	M6

FLANGIA B14

B14 FLANGE

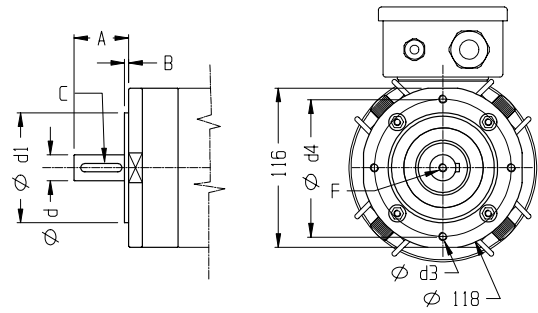

Size	A	B	C	d(h7)	d1(h7)	d3	d4	F
71	30	2.5	5x5x25	14	70	M6	85	M5
80	40	3	6x6x30	19	80	M6	100	M6

PENTA 7A

MOTORI C.C.

D.C. MOTORS



OPTIONALS

PIEDE A FASCIA

FOOT BAND TYPE

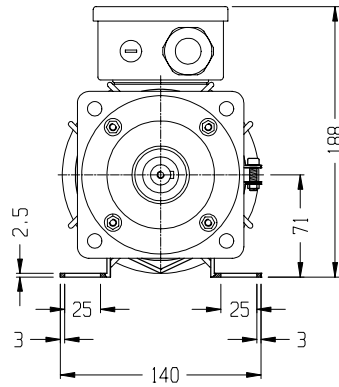
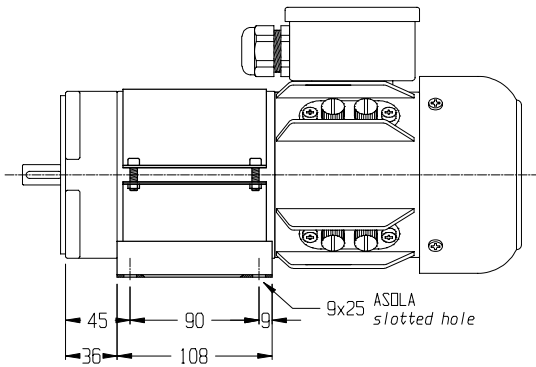

SOLO TAGLIA S
ONLY TYPE S

PIEDE A FASCIA

FOOT BAND TYPE

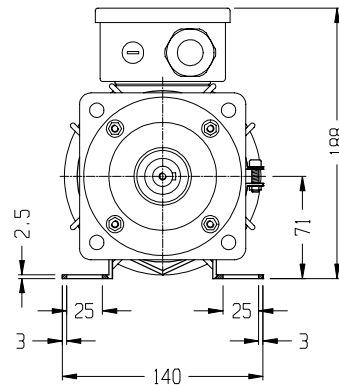
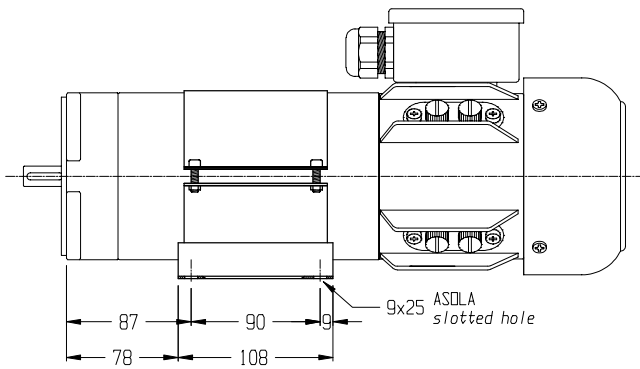

SOLO TAGLIA M
ONLY TYPE M

PIEDE A FASCIA

FOOT BAND TYPE

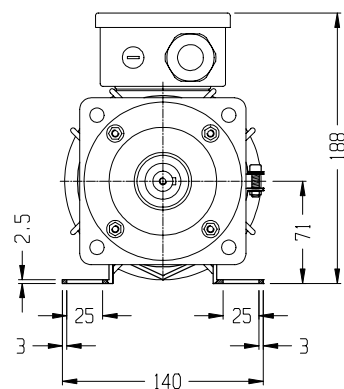
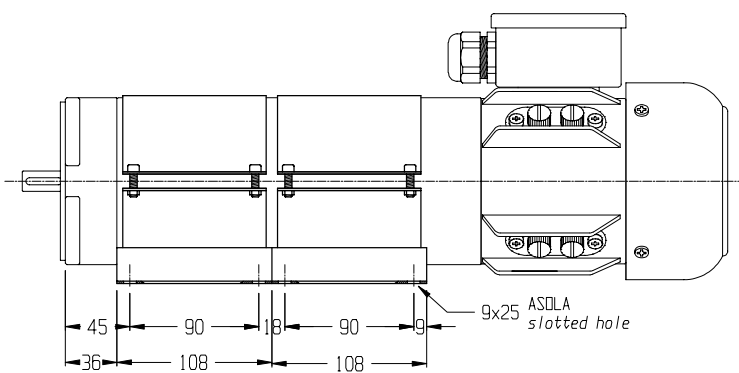

SOLO TAGLIA L
ONLY TYPE L

PENTA 7A

MOTORI C.C.

D.C. MOTORS



OPTIONALS

DIN. TACHIMETRICA TACHO GENERATOR

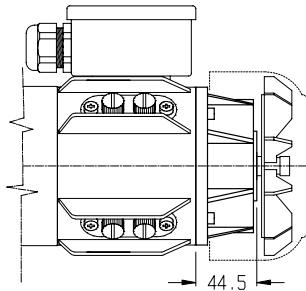

LA LUNGHEZZA TOTALE DEL MOTORE AUMENTA DI 10 mm

COSTANTE DI TENSIONE VOLTAGE CONSTANT	10±5% V/KRPM	CORRENTE NOMINALE RATED CURRENT	2 mA
VELOCITA' MASSIMA MAX SPEED	9000 RPM	CORRENTE MASSIMA MAX CURRENT	8 mA

FRENO 8 Nm BRAKE 8 Nm

BRAKE 8 Nm

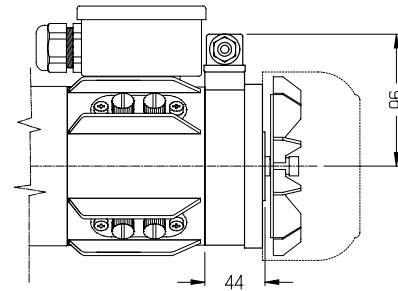

LA LUNGHEZZA TOTALE DEL MOTORE AUMENTA DI 42 mm

COPPIA STATICA STATIC TORQUE	8 Nm	CORRENTE CURRENT	1-0.13 A
TENSIONE DI ALIMEN. POWER SUPPLY VOLTAGE	24-190 V.c.c.	POTENZA ASSORBITA INPUT POWER	24 W

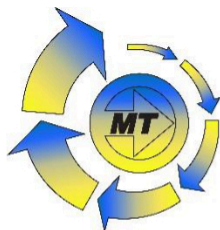

Distributors for Australia & New Zealand
MOTION TECHNOLOGIES PTY LIMITED

24/22-30 Northumberland Road
Caringbah NSW 2229 Australia
Phone: (02) 9524 4782

sales@motiontech.com.au
www.motiontech.com.au

© 21/03/22