

**Compact
and Precise!**



new
MiniStage
motorized with
Hybrid Stepper Actuator

Small is big, in advanced automation!

Combines core HKP hybrid actuator and lead screw technology with the guidance and load handling capacities of a recirculating ball bearing profile rail.

Low-profile miniature rail provides increased moment load and stiffness

Nema size 8 motor with integrated screw for reduced overall length

Mounting flexibility and system stiffness through baseplate

Several screw lead / resolution options

Several rotary encoder options

Optional anti-backlash nut

Size 8 Hybrid Stepper Linear Actuator: 21 mm (0.8-in) (1.8° Step Angle)			
Wiring	Bipolar		
Winding Voltage	2.5 VDC	5 VDC	7.5 VDC
Current (RMS)/phase	.49 A	.24 A	.16 A
Resistance/phase	5.1 Ω	20.4 Ω	45.9 Ω
Inductance/phase	1.5 mH	5.0 mH	11.7 mH
Power Consumption	2.45 W		
Rotor Inertia	1.4 gcm ²		
Insulation Class	Class B (Class F available)		
Weight	1.5 oz (43 g)		
Insulation Resistance	20 MΩ		

MiniStage Load Specifications	
Design Payload (mass)	3.6kg [8 lbs]
Axial Force	45N [10 lbf]
Roll Moment*	1.13N-m [10 lbf-in]
Pitch Moment*	1.13N-m [10 lbf-in]
Yaw Moment*	0.9N-m [8 lbf-in]
Repeatability	+/-25µm [0.001 in]

* Moment data based on 0.25° deflection

Ordering Part Numbers for MiniStage™ motorized with Size 8 Hybrid Stepper Actuator

MLX	02	K	—	M	0315	—	E	X	M	—	Axx
Prefix	Nominal Screw Diameter	Screw Coating		Drive Type	Lead Code		Rotary Encoder		Carriage Mounting		Stroke / Unique Identifier
MLX = MiniStage	02 = 0.13" (3.5mm)	K = Kerkote® (standard) S = Uncoated B = Black Ice G = Grease		M = Motorized, Stepper	0012 = 0.012" lead 0020 = 0.5mm lead 0024 = 0.024" lead 0039 = 1mm lead 0048 = 0.048" lead 0079 = 2mm lead 0096 = 0.096" lead 0157 = 4mm lead 0315 = 8mm lead		E = encoder X = no encoder		E = Imperial M = Metric		Axx = Unique identifier (e.g. A01) 802 = 25mm stroke 805 = 50mm stroke 807 = 75mm stroke 810 = 100mm stroke

NOTE: Dashes must be included in the Part Number (-) as shown above. For assistance call our Engineering Team at 203 756 7441.

Force vs. Pulse Rate

- Chopper
- 100% Duty Cycle
- Bipolar
- Ø.14 (3.56) Lead Screw

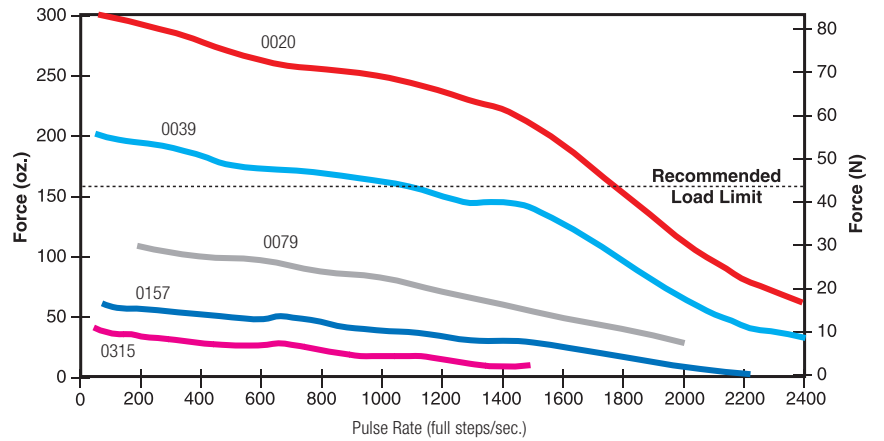
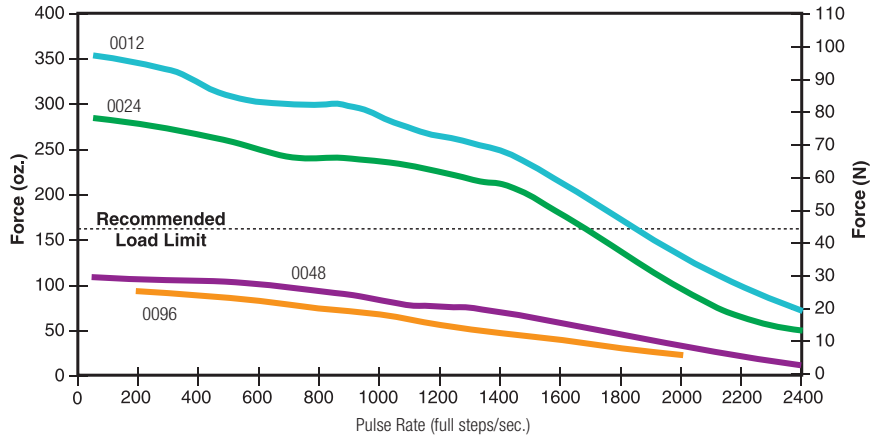

Force vs. Linear Velocity

- Chopper
- 100% Duty Cycle
- Bipolar
- Ø.14 (3.56) Lead Screw

NOTE: All chopper drive curves were created with a 5 volt motor and a 40 volt power supply. Ramping can increase the performance of a motor either by increasing the top speed or getting a heavier load accelerated up to speed faster. Also, deceleration can be used to stop the motor without overshoot. With L/R drives peak force and speeds are reduced, using a unipolar drive will yield a further 30% force reduction.

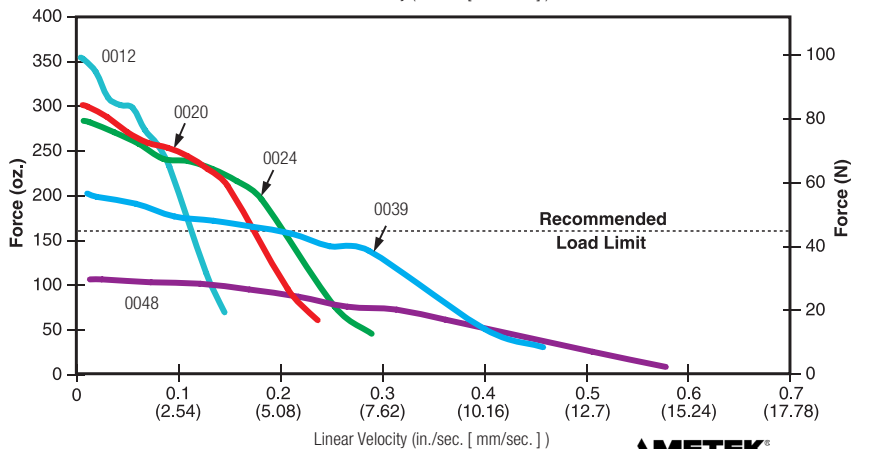
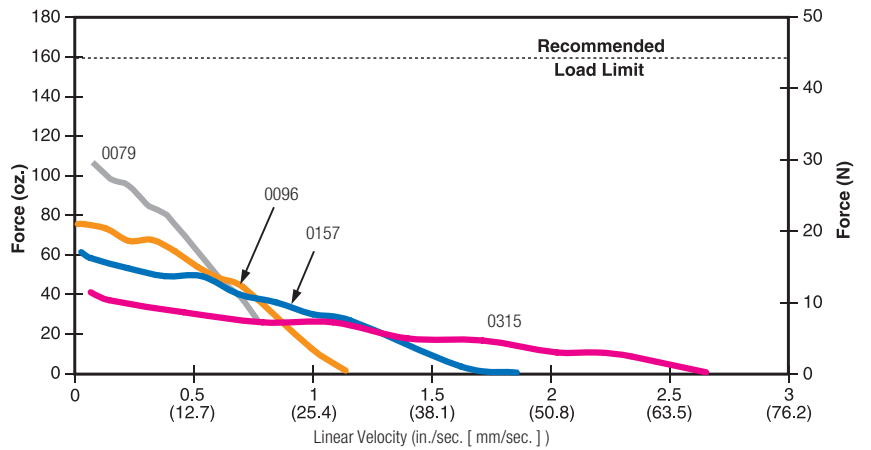

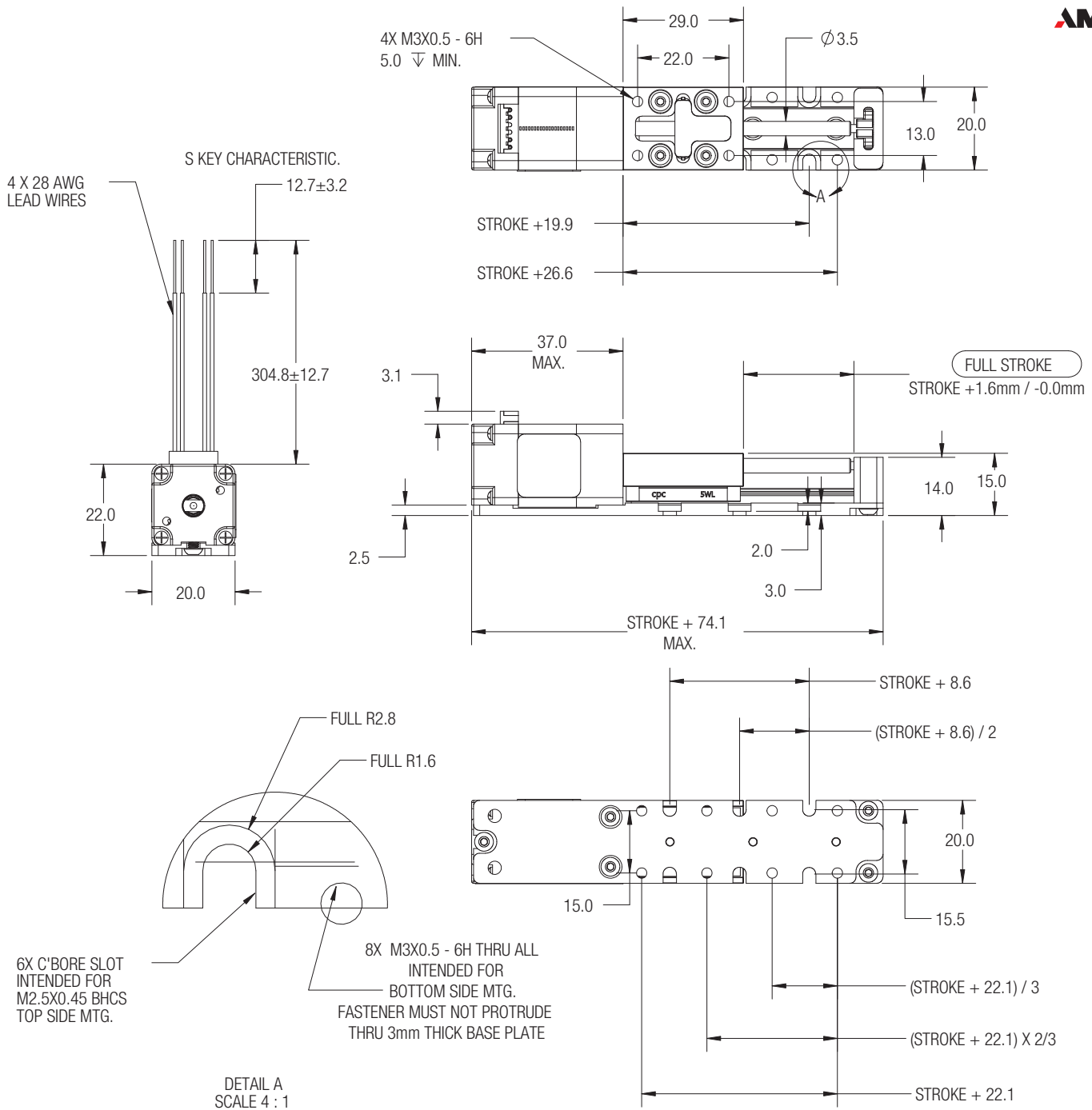

Wiring: Bipolar

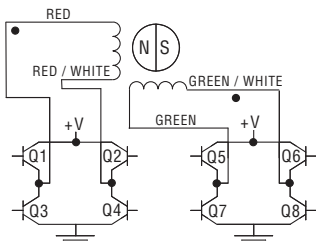

Can-Stack Motor Stepping Sequence

Bipolar Step	Q2-Q3	Q1-Q4	Q6-Q7	Q5-Q8
1	ON	OFF	ON	OFF
2	OFF	ON	ON	OFF
3	OFF	ON	OFF	ON
4	ON	OFF	OFF	ON
1	ON	OFF	ON	OFF

EXTEND CW \downarrow

RETRACT CCW \uparrow

Note: Half stepping is accomplished by inserting an off state between transitioning phases.

Encoders for MLX Rails

MLX Series rails are available with specifically designed encoders for applications that require feedback. The compact optical incremental encoder designs are available with two channel quadrature TTL squarewave outputs. Various resolutions are available, up to 1000 CPR.

Simplicity and low cost make the encoders ideal for both high and low volume motion control applications. The internal monolithic electronic module converts the real-time shaft angle, speed, and direction into TTL compatible outputs. The encoder modules incorporate a lensed LED light source and monolithic photodetector array with signal shaping electronics to produce the two channel bounceless TTL outputs.



21mm 21000 Series Size 8

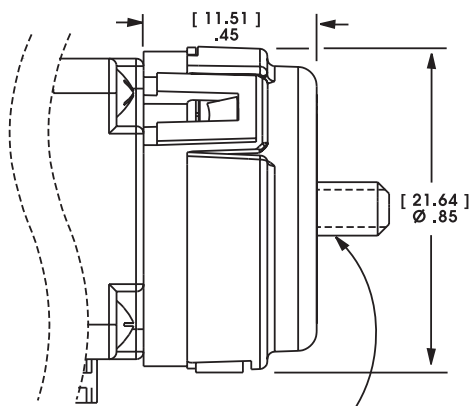

NOTE: Lead Screw extends beyond encoder on specific captive and non-captive motors. External linear shaft extension is available upon request.

Pinouts			
Single-Ended		Differential	
Connector Pin #	Description	Connector Pin #	Description
1	+5 VDC Power	1	Ground
2	Channel A	2	A channel
3	Ground	3	A- channel
4	Channel B	4	+5VDC power
		5	B channel
		6	B- channel

Electrical Specifications				
	Minimum	Typical	Maximum	Units
Input Voltage	4.5	5.0	5.5	VDC
Output Voltage	4.5	5.0	5.5	VDC

2 channel quadrature TTL squarewave outputs.
Channel B leads A for a clockwise rotation of the rotor viewed from the encoder cover.
Tracks at speeds of 0 to 100,000 cycles/sec.

Operating Temperature		
Size 8	Minimum	Maximum
	- 20°C (28°F)	100°C (212°F)

Mechanical Specifications	
	Maximum
Acceleration	250,000 rad/sec ²
Vibration (5 Hz to 2 kHz)	20 g

Resolution				
Size 8	Standard Resolutions (CPR)			Maximum (CPR)
		200	400	1000

Other Resolutions Available - Contact Factory