



www.motiontech.com.au

BASKA®

COUPLINGS/BACKSTOPS

CATALOG



BEIJING BASKA TECHNOLOGY CO.,LTD

CONTENT

Company Introduction	2	Backstops	
Company Culture	3	Features of DSN Backstops	18
		Typical Application Patterns	19
Grid Couplings		Model Selection and Parameters	20
Features of Spring Coupling	4	Dimension for Installation.....	21
G10 Series	5	Design and Parameter of Installation Shaft	22
G05 Series Taper Bushing Connect	6	Design and Parameter of Key on Shaft.....	23
G31/G0531 Series Double Flanges	7	Design of anti-rotation iron	24
G35/G0535 Series Single Flange	8	Typical arrangement of backstop and anti-rotation	25
G61/G0561 Series Brakewheel	9		
G63/G0563 Series Brake Disc	11	Customer service	26
Allowable Misalignment	12	Technical Agreement of Coupling	
		Technical Agreement of Backstops	
Drum Gear Couplings			
GIICL Series Drum Gear Coupling	13		
GIICL Series.....	14		
GIICLG05 Series Taper Bushing Connect	15		
Shaft hole Type and Connecting Type	16		
Coupling Selection Procedure	17		

Focus on Transmission Field Over 30 Years Global Innovative Hydraulic Spring Coupling More Reliable More Efficient

BASKA Let power transmit smoothly!

Beijing Baska Technology Company Limited is a modern high-tech enterprise integrates research, development, design, manufacture, sales and services. Baska sets the manufacturing base in the equipment manufacture industry park in Datong, Shanxi Province, and several regional branches in Xinjiang, Inner Mongolia, Ningxia, Gansu, Shaanxi, Guizhou, Shanxi and Anhui, Wuhan, Chongqing, Shanghai, Guangzhou Provinces.

BASKA is a professional equipment manufacturer in both hydraulic transmission and mechanical transmission fields, and provides integrated solutions for multi-series power transmission systems. Our revolutionary innovation—shaft-hub hydraulic connecting technology—is leading a product revolution of shaft-hub connection field including couplings, and bearings, which is characterized by compact structure, quick installation, easy positioning, little runout, contact surface protection and convenient dismantling. Main products are hydraulic spring coupling, hydraulic drum gear coupling, hydraulic pin and bush coupling, backstop, hydraulic sleeve set for bearing.

BASKA products are facing mining, chemical, steel, electricity, cement, metallurgy, port, shipbuilding, papermaking, special slurry industries and etc. Beijing Baska has acquired many national patent, and passed several domestic and international authority certifications, including ISO international quality certificate, France BV certificate, Germany TUV certificate, safety certificate for coal mining products.

BASKA adheres to the core value of "Simplicity, Learning, Young, Commitment", operation philosophy of "respect value", and development concept of "people-oriented". BASKA is persisting in the pursuit of perfection to become a global, modern, robust, and standardized corporation.

CULTURE is like sky, all embraced
is like water, all moistened

The culture of BASKA is spiritual sustenance and spiritual belonging, all staff approved value orientation and judgment. Also the shared belief gradually formed in time and intravenous drip of accumulation and precipitation of every employee.



Transmission Features of Spring Coupling

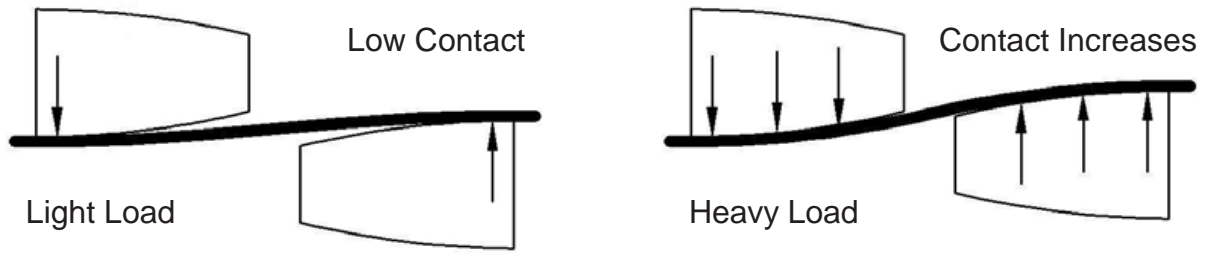

Superior Cushion Performance

According to the actual working load of coupling, the Baska grid spring will deform to different extent correspondently to fit the tooth on the wheel, dampen vibration and shocks, and therefore protect the hosting equipment well.

Long Service Life

Baska grid spring is made of high-quality alloy steel. Through strict heat treatment and special processing, the material reaches its best performance in both strength and resilience. It greatly outlasts other non-metallic elastic element coupling.

Quick Installation and Easy Maintenance

The cover of coupling can be quickly removed by using ordinary tools, and then replace the worn spring with a new set. Neither the replacement of shaft sleeve is necessary, nor is the repositioning or realigning the shaft hubs, which saves a lot of time.

High Safety Level

Baska spring coupling is able to undertake a wide range of torsional load, and the instantaneous overload can reach 200% of rated torque.

Professional Design and Various Types

Various designs of spring coupling are available to choose: basic type, taper bushings clearance fitting, hydraulic interference fitting, single- or double- flange type, brake wheel type, brake disk type, etc. Fulfill clients' different requirements.

Low Lifetime Operating Cost

The lifetime operating cost of Baska spring coupling is lower than other types of coupling. Under normal use condition, periodic maintenance is not required as long as sufficient grease is filled when installation, and change the grease after longtime working.

G10 Series Keyed Connect Spring Coupling

Main Features:

- Good Cushioning Performance
- High Safety Level
- Low Installation Requirement

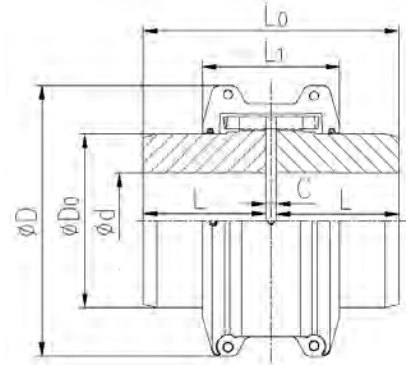
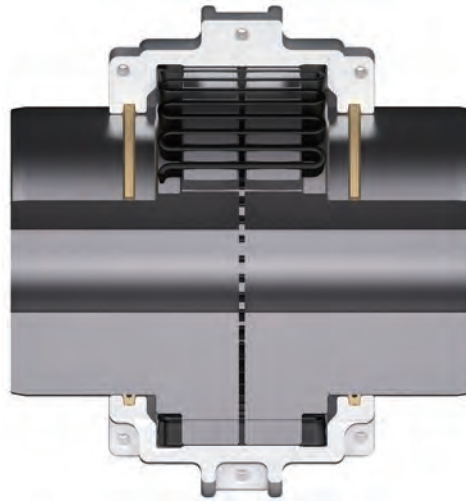

Item No.	Nominal torque Tn	Allow speed n	Maximum shsft hole d	shsft hole length L	length L0	L1	D	D0	Gap C	Weight (no bore)	Rotation inertia I	Grease amount
	N.m	rpm	mm	mm	mm	mm	mm	mm	mm	kg	kg.m ²	kg
1080G10	2050	3600	80	95	193	116	190	104.8	3	19	0.0451	0.172
1090G10	3730	3600	95	105	213	122	210	123.8	3	27	0.0787	0.254
1100G10	6280	2440	110	125	255	156	252	142.1	5	44	0.1780	0.426
1110G10	9320	2250	120	135	275	163	272	160.3	5	58	0.2700	0.508
1120G10	13700	2025	140	155	316	192	310	179.4	6	85	0.5140	0.735
1130G10	19900	1800	170	175	356	195	348	217.5	6	131	0.9590	0.908
1140G10	28600	1650	200	190	386	201	386	254.0	6	184	1.8500	1.135
1150G10	39800	1500	215	200	406	269	454	269.2	6	256	3.4900	1.952
1160G10	55900	1350	240	215	436	279	510	304.8	6	344	5.8200	2.815
1170G10	74600	1225	280	230	466	300	567	355.0	6	477	10.400	3.496
1180G10	103000	1100	300	270	546	321	632	394.0	6	701	18.300	3.768
1190G10	137000	1050	320	290	586	325	680	437.0	6	869	26.100	4.400
1200G10	186000	900	360	320	646	356	756	497.8	6	1212	43.500	5.630
1210G10	249000	820	380	350	713	435	848	533.4	13	1637	75.500	10.53
1220G10	336000	730	420	390	793	380	872	571.5	13	2143	113.00	16.07
1230G10	435000	680	450	420	853	440	957	609.6	13	2758	175.00	24.06
1240G10	559000	630	480	450	913	506	1048	647.7	13	3643	339.00	33.82
1250G10	746000	580	500	480	973	560	1143	711.2	13	4352	524.00	50.17
1260G10	932000	540	540	500	1013	618	1252	762	13	5118	711.00	67.24
1270G10	1130000	460	570	500	1100	686	1381	870	20	6828	932.00	82.35

G05 Series Taper Bushing Connect Spring Coupling

Main Features:

- Quick Installation and Dismounting
- Easy Maintenance

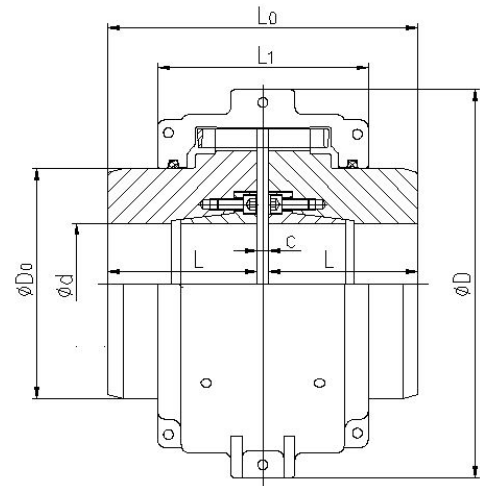
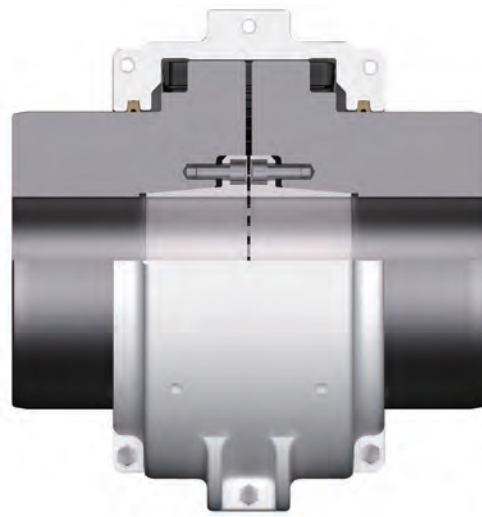

Item No.	Nominal torque T _n	Allow speed n	Maximum shsft hole d	shsft hole length L	length L ₀	L ₁	D	D ₀	Gap C	Weight (no bore)	Rotation inertia I	Grease amount
	N.m	rpm	mm	mm	mm	mm	mm	mm	mm	kg	kg.m ²	kg
1080G05	2050	3600	55	95	193	116	190	104.8	3	19	0.0451	0.172
1090G05	3730	3600	66.68	105	213	122	210	123.8	3	27	0.0787	0.254
1100G05	6280	2440	85	125	255	156	252	142.1	5	44	0.1780	0.426
1110G05	9320	2250	100	135	275	163	272	160.3	5	58	0.2700	0.508
1120G05	13700	2025	120	155	316	192	310	179.4	6	85	0.5140	0.735
1130G05	19900	1800	140	175	356	195	348	217.5	6	131	0.9590	0.908
1140G05	28600	1650	160	190	386	201	386	254.0	6	184	1.8500	1.135
1150G05	39800	1500	180	200	406	269	454	269.2	6	256	3.4900	1.952
1160G05	55900	1350	200	215	436	279	510	304.8	6	344	5.8200	2.815
1170G05	74600	1225	230	230	466	300	567	355.0	6	477	10.400	3.496
1180G05	103000	1100	260	270	546	321	632	394.0	6	701	18.300	3.768
1190G05	137000	1050	300	290	586	325	680	437.0	6	869	26.100	4.400
1200G05	186000	900	340	320	646	356	756	497.8	6	1212	43.500	5.630
1210G05	249000	820	360	350	713	435	848	533.4	13	1637	75.500	10.53
1220G05	336000	730	400	390	793	380	872	571.5	13	2143	113.00	16.07
1230G05	435000	680	420	420	853	440	957	609.6	13	2758	175.00	24.06
1240G05	559000	630	450	450	913	506	1048	647.7	13	3643	339.00	33.82
1250G05	746000	580	460	480	973	560	1143	711.2	13	4352	524.00	50.17
1260G05	932000	540	500	500	1013	618	1252	762	13	5118	711.00	67.24
1270G05	1130000	460	520	540	1100	686	1381	870	20	6828	932.00	82.35

G31 Series Keyed Connect Spring Coupling with Two Flanges

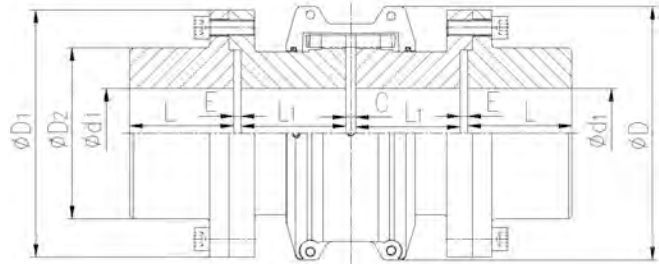
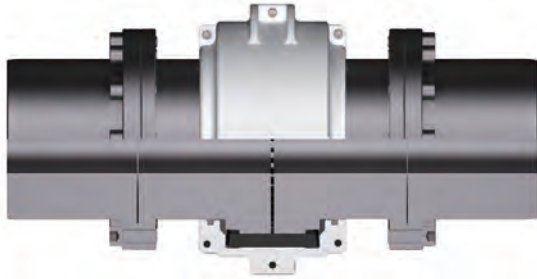

Item No.	Nominal torque T _n N.m	Allow speed n rpm	Maximum shaft hole d ₁ mm	shaft hole length L mm	Middle part length		D mm	D ₁ mm	D ₂ mm	Gap C mm	Gap E mm	Weight (no bore) kg	Grease amount kg
					Min. L ₁ mm	Max. L ₁ mm							
1080G31	2050	3600	95	95	95	204	190	178	122	5	1.5	41	0.172
1090G31	3730	3600	110	105	105	204	210	210	142	5	1.5	63	0.254
1100G31	6280	2440	130	125	125	205	252	251	172	6	2	115	0.426
1110G31	9320	2250	150	135	135	205	272	276	198	6	2	158	0.508
1120G31	13700	2025	170	155	155	205	310	319	225	10	2	235	0.735
1130G31	19900	1800	190	175	175	205	348	346	238	10	2	318	0.908
1140G31	28600	1650	210	190	190	205	386	386	268	10	2	416	1.135

G0531 Series Taper Bushing Connect Spring Coupling with Two Flanges

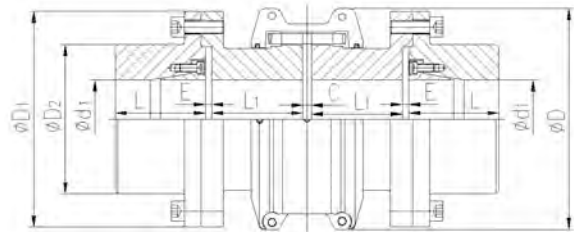
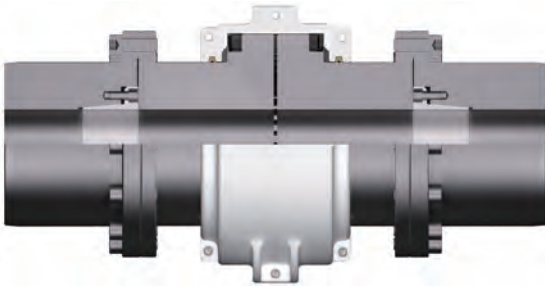

Item No.	Nominal torque T _n N.m	Allow speed n rpm	Maximum shaft hole d ₁ mm	shaft hole length L mm	Middle part length		D mm	D ₁ mm	D ₂ mm	Gap C mm	Gap E mm	Weight (no bore) kg	Grease amount kg
					Min. L ₁ mm	Max. L ₁ mm							
1080G0531	2050	3600	55	95	95	204	190	178	122	5	1.5	41	0.172
1090G0531	3730	3600	66.68	105	105	204	210	210	142	5	1.5	63	0.254
1100G0531	6280	2440	85	125	125	205	252	251	172	6	2	115	0.426
1110G0531	9320	2250	110	135	135	205	272	276	198	6	2	158	0.508
1120G0531	13700	2025	130	155	155	205	310	319	225	10	2	235	0.735
1130G0531	19900	1800	140	175	175	205	348	346	238	10	2	319	0.908
1140G0531	28600	1650	150	190	190	205	386	386	268	10	2	416	1.135

G35 Series Keyed Connect Spring Coupling with Single Flange

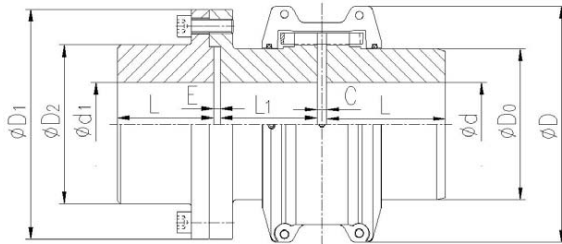
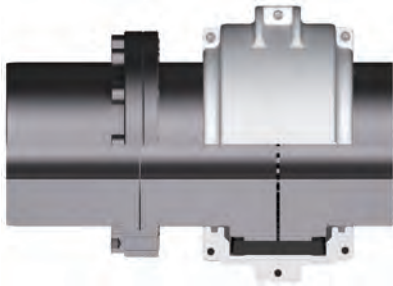

Item No.	Nominal torque T _n	Allow speed n	Maximum shaft hole d ₁	Maximum shaft hole d	shaft hole length L	Middle part length		D	D ₁	D ₂	Gap C	Gap E	Weight (no bore)	Grease amount
	N.m	rpm	mm	mm	mm	Min. L ₁	Max. L ₁							
1080G35	2050	3600	95	80	95	95	204	190	178	122	3	1.5	31	0.172
1090G35	3730	3600	110	95	105	105	204	210	210	142	3	1.5	44	0.254
1100G35	6280	2440	130	110	125	125	205	252	251	172	5	2	76	0.426
1110G35	9320	2250	150	120	135	135	205	272	276	198	5	2	113	0.508
1120G35	13700	2025	170	140	155	155	205	310	319	225	6	2	143	0.735
1130G35	19900	1800	190	170	175	175	205	348	346	238	6	2	192	0.908
1140G35	28600	1650	210	200	190	190	205	386	386	268	6	2	262	1.135

G0535 Series Taper Bushing Connect Spring Coupling with Single Flange

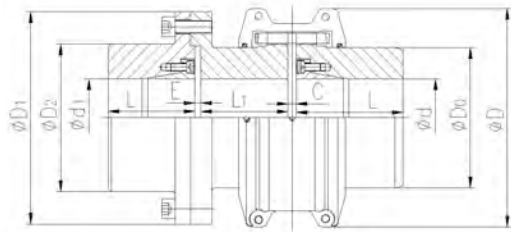
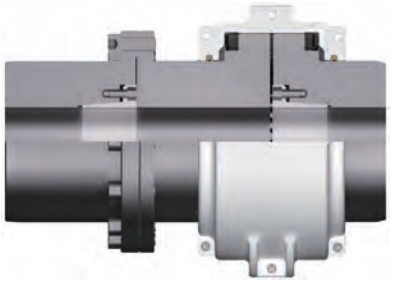

Item No.	Nominal torque T _n	Allow speed n	Maximum shaft hole d ₁	Maximum shaft hole d	shaft hole length L	Middle part length		D	D ₁	D ₂	Gap C	Gap E	Weight (no bore)	Grease amount
	N.m	rpm	mm	mm	mm	Min. L ₁	Max. L ₁							
1080G0535	2050	3600	55	55	95	95	204	190	178	122	3	1.5	31	0.172
1090G0535	3730	3600	66.68	66.68	105	105	204	210	210	142	3	1.5	44	0.254
1100G0535	6280	2440	85	85	125	125	205	252	251	172	5	2	76	0.426
1110G0535	9320	2250	110	100	135	135	205	272	276	198	5	2	113	0.508
1120G0535	13700	2025	130	120	155	155	205	310	319	225	6	2	143	0.735
1130G0535	19900	1800	140	140	175	175	205	348	346	238	6	2	192	0.908
1140G0535	28600	1650	150	160	190	190	205	386	386	268	6	2	262	1.135

G61 Series Keyed Connect Spring Coupling with Brake Wheel

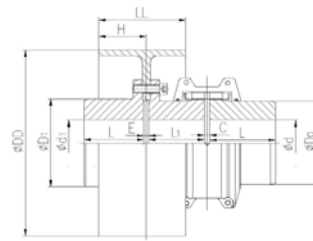
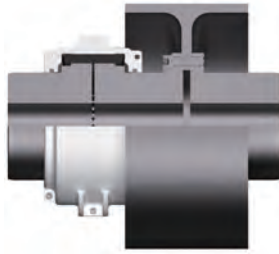

Main parameters of coupling											Parameters of brake wheel						
Item No.	Normal torque Tn	Max.shaft hole d1	Max.shaft hole d	Max.shaft length L	Max.shaft length L1	D1	D0	Gap C	Weight (no bore)	Grease amount	Dimension DD*LL	Application range	Allow speed n	Brake torque Tn	Gap E	H	Weight (no bore)
	N.m	mm	mm	mm	mm	mm	mm	mm	kg	kg		mm					
1080G61	2050	95	80	95	95	122	104.8	3	31	0.172	315*135	1080-1100	2400	900	15	90	30
1090G61	3730	110	95	105	105	142	123.8	3	44	0.254							
1100G61	6280	130	110	125	125	172	142.1	5	76	0.426	400*170	1090-1110	1900	1200	20	110	62
1110G61	9320	150	120	135	135	198	160.3	5	113	0.508	500*210	1100-1120	1500	1600	20	120	96
1120G61	13700	170	140	155	155	225	179.4	6	143	0.735	630*265	1120-1140	1200	2000	20	145	173
1130G61	19900	190	170	175	160	238	217.5	6	192	0.908	710*300	1130-1150	1050	2250	25	120	236
1140G61	28600	210	200	190	170	268	254.0	6	262	1.135	800*335	1140-1150	950	2500	25	150	328
1150G61	39800	240	215	200	190	298	269.2	6	336	1.952							

G0561 Series Taper Bushing Connect Spring Coupling with Brake Wheel

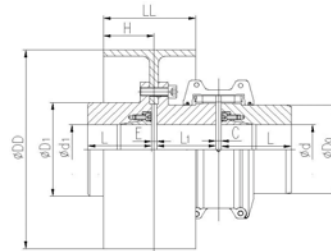
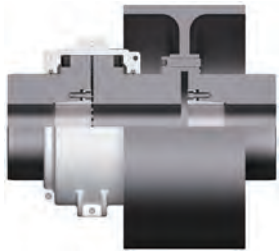

Main parameters of coupling											Parameters of brake wheel						
Item No.	Normal torque Tn	Max.shaft hole d1	Max.shaft hole d	Max.shaft length L	Max.shaft length L1	D1	D0	Gap C	Weight (no bore)	Grease amount	Dimension DD*LL	Application range	Allow speed n	Brake torque Tn	Gap E	H	Weight (no bore)
	N.m	mm	mm	mm	mm	mm	mm	mm	kg	kg		mm					
1080G0561	2050	55	55	95	95	122	104.8	3	31	0.172	315*135	1080-1100	2400	900	15	90	30
1090G0561	3730	66.68	66.68	105	105	142	123.8	3	44	0.254							
1100G0561	6280	85	85	125	125	172	142.1	5	76	0.426	400*170	1090-1110	1900	1200	20	110	62
1110G0561	9320	110	100	135	135	198	160.3	5	113	0.508	500*210	1100-1120	1500	1600	20	120	96
1120G0561	13700	130	120	155	155	225	179.4	6	143	0.735	630*265	1120-1140	1200	2000	20	145	172
1130G0561	19900	140	140	175	160	238	217.5	6	192	0.908	710*300	1130-1150	1050	2250	25	120	236
1140G0561	28600	150	160	190	170	268	254.0	6	262	1.135	800*335	1140-1150	950	2500	25	150	328
1150G0561	39800	190	180	200	190	298	269.2	6	336	1.952							

G63 Series Keyed Connect Spring Coupling with Brake

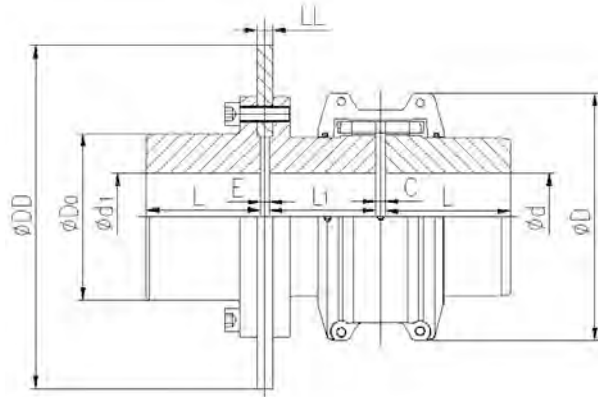
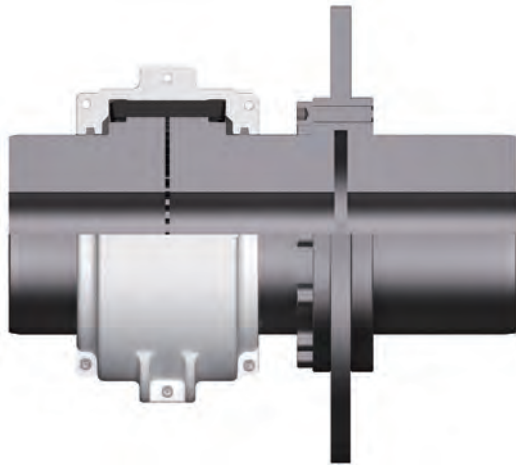

Item No.	Norminal torque Tn	Brake torque Tn	Allow speed n	Max.shaft hole d ₁	Max.shaft hole d	shaft hole length L	Mid part length L ₁	D ₀	D	Gap C	Gap E	Weight (no bore)	Grease amount
	N.m	N.m	rpm	mm	mm	mm	mm	mm	mm	mm	mm	kg	kg
1080G63	2050	680	3160	95	80	95	95	122	190	3	20	31	0.172
1090G63	3730	1240	3060	110	95	105	105	142	210	3	20	44	0.254
1100G63	6280	2090	2074	130	110	125	125	172	252	5	20	76	0.426
1110G63	9320	3100	1900	150	120	135	135	198	272	5	20	113	0.508
1120G63	13700	4500	1750	170	140	155	155	225	310	6	20	143	0.735
1130G63	19900	6600	1550	190	170	175	160	238	348	6	20	192	0.908
1140G63	28600	9500	1450	210	200	190	170	268	386	6	20	262	1.135
1150G63	39800	13200	1300	240	215	200	190	298	454	6	20	336	1.952
1160G63	55900	18600	1150	265	240	215	200	328	510	6	20	480	2.815
1170G63	74600	24800	950	310	280	230	210	390	567	6	20	660	3.496
1180G63	103000	34300	920	325	300	270	220	430	632	6	30	911	3.768
1190G63	137000	45600	890	350	320	290	240	480	680	6	30	1128	4.400
1200G63	186000	62000	820	390	360	320	260	530	756	6	30	1572	5.630
1210G63	249000	83000	780	420	380	350	310	580	848	13	30	2126	10.53
1220G63	336000	112000	650	450	420	390	330	620	872	13	30	2785	16.07
1230G63	435000	145000	550	490	450	420	380	660	957	13	30	3584	24.06
1240G63	559000	186000	500	520	480	450	420	705	1048	13	30	4735	33.82

Brake disc	Outside diameter DD(mm)	315	355	400	450	500	560	630	710	800	900	1000	1250	1600	2000
	Thickness LL(mm)	30													

G0563 Series Taper Bushing Connect Spring Coupling

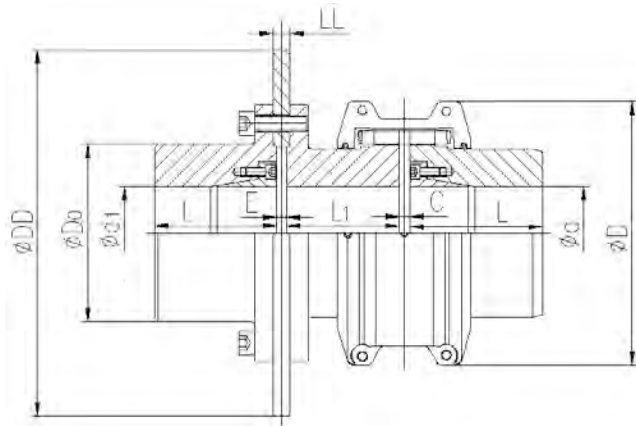
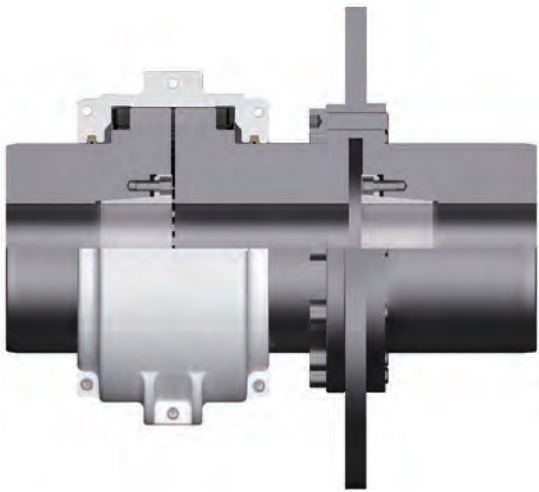

Item No.	Norminal torque Tn	Brake torque Tn	Allow speed n	Max.shaft hole d ₁	Max.shaft hole d	shaft hole length L	Midpart length L ₁	Do	D	Gap C	Gap E	Weight (no bore)	Grease amount
	N.m	N.m	rpm	mm	mm	mm	mm	mm	mm	mm	mm	kg	kg
1080G0563	2050	680	3160	55	55	95	95	122	190	3	20	31	0.172
1090G0563	3730	1240	3060	66.68	66.68	105	105	142	210	3	20	44	0.254
1100G0563	6280	2090	2074	85	85	125	125	172	252	5	20	76	0.426
1110G0563	9320	3100	1900	110	100	135	135	198	272	5	20	113	0.508
1120G0563	13700	4500	1750	130	120	155	155	225	310	6	20	143	0.735
1130G0563	19900	6600	1550	140	140	175	160	238	348	6	20	192	0.908
1140G0563	28600	9500	1450	150	160	190	170	268	386	6	20	262	1.135
1150G0563	39800	13200	1300	190	180	200	190	298	454	6	20	336	1.952
1160G0563	55900	18600	1150	200	200	215	200	328	510	6	20	480	2.815
1170G0563	74600	24800	950	220	230	230	210	390	567	6	20	660	3.496
1180G0563	103000	34300	920	250	260	270	220	430	632	6	30	911	3.768
1190G0563	137000	45600	890	290	300	290	240	480	680	6	30	1128	4.400
1200G0563	186000	62000	820	320	340	320	260	530	756	6	30	1572	5.630
1210G0563	249000	83000	780	340	360	350	310	580	848	13	30	2126	10.53
1220G0563	336000	112000	650	380	400	390	330	620	872	13	30	2785	16.07
1230G0563	435000	145000	550	400	420	420	380	660	957	13	30	3584	24.06
1240G0563	559000	186000	500	420	450	450	420	705	1048	13	30	4735	33.82

Brake disc	Outside diameter DD(mm)	315	355	400	450	500	560	630	710	800	900	1000	1250	1600	2000
	Thickness LL(mm)	30													

Allowable Misalignment When Mounting Spring Coupling

Maximum life and minimum maintenance for the coupling and connected machinery will result if couplings are accurately aligned. Coupling life expectancy between initial alignment and maximum operating limits is a function of load, speed and lubrication. So misalignment must be within its maximum operating limits at installation and operation.

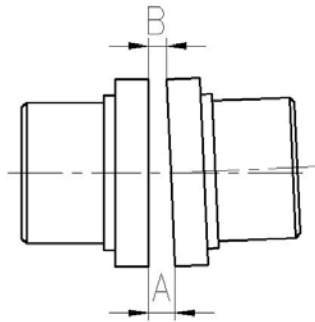

Angular Misalignment

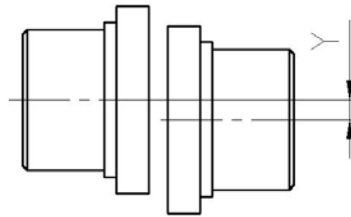

Radial Misalignment

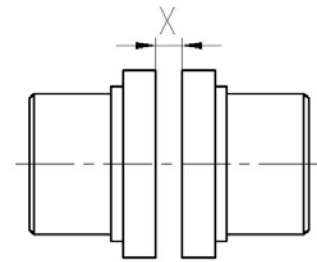

Axial Clearance

Allowable Offset Spring Coupling

Model	Maximum allowable misalignment at installation		Maximum compensation at operating		Axial Clearance $\pm 10\%$	
	Radial	Angular	Radial	Angular	Models Except G31, G0531	G31 G0531
	Y	A-B	Y	A-B		
1080	0.20	0.15	0.41	0.61	3	5
1090	0.20	0.18	0.41	0.71	3	5
1100	0.25	0.20	0.51	0.84	5	6
1110	0.25	0.23	0.51	0.91	5	6
1120	0.28	0.25	0.56	1.02	6	10
1130	0.28	0.30	0.56	1.19	6	10
1140	0.28	0.33	0.56	1.35	6	10
1150	0.30	0.41	0.61	1.57	6	
1160	0.30	0.46	0.61	1.78	6	
1170	0.30	0.51	0.61	2.01	6	
1180	0.38	0.56	0.76	2.26	6	
1190	0.38	0.61	0.76	2.46	6	
1200	0.38	0.69	0.76	2.72	6	
1210	0.46	0.74	0.91	3.00	13	
1220	0.46	0.81	0.91	3.28	13	
1230	0.46	0.89	0.97	3.61	13	
1240	0.48	0.97	0.97	3.91	13	
1250	0.51	1.07	1.02	4.29	13	
1260	0.51	1.17	1.02	4.65	13	
1270	0.62	1.27	1.17	5.21	20	

GIICL Type Drum Gear Coupling Series



Structural Features

◆ High Loading Capacity:

With the same external dimension, the loading capacity is 15%~20% averagely higher than that of straight-tooth coupling

◆ Large Angular Compensation:

The maximum allowable angular misalignment is 1.5°, 50% higher than that of straight-tooth coupling

◆ Scientific Gear Tooth Design:

It avoids local stress concentration caused by straight tooth edge extrusion, and tooth surface friction is eased at the same time

◆ Gear tooth of external gear sleeve is horn-shaped, which makes it easy to install and dismount.

◆ High Transmission Efficiency Can Reach 99.7%

Performance Advantages

Gear teeth are made of high-strength alloy steel. Through quenched-tempered heat treatment, ionitriding, hardness of teeth surface is highly improved, and more wear-resistant. Therefore, service life is longer.

GIICL Series Keyed Connect Drum Gear Coupling

GIICL1—GIICL13

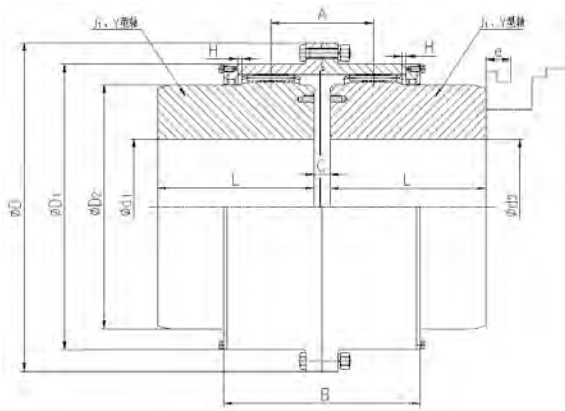

GIICL14—GIICL20

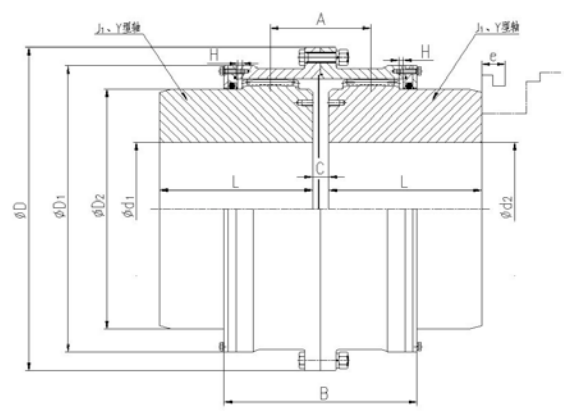

Item No.	Nominal torque Tn	Allow speed n	Shaft hole diameter		Shaft hole length L		D	D ₁	D ₂	C	H	A	B	e	Rotation inertia I	Grease amount	Weight
			d ₁ , d ₂	Ytype shaft	J1type shaft												
	N.m	r/min	mm											kg.m ²	ml	kg	
GIICL1	400	4000	16~35	42~82	38~60	103	71	50	8	2	36	76	38	0.00375	51	4	
GIICL2	710	4000	20~45	52~112	44~84	115	83	60	8	2	42	88	42	0.00675	70	6	
GIICL3	1120	4000	22~56	52~112	44~84	127	95	75	8	2	44	90	42	0.0113	68	9	
GIICL4	1800	4000	38~65	82~142	60~107	149	116	90	8	2	49	98	42	0.0245	87	15	
GIICL5	3150	4000	40~75	112~142	84~107	167	134	105	10	2.5	55	108	42	0.0433	125	20	
GIICL6	5000	4000	45~90	112~172	84~132	187	153	125	10	2.5	56	110	42	0.0843	148	31	
GIICL7	7100	3750	50~105	112~212	84~167	204	170	140	10	2.5	60	118	42	0.151	175	48	
GIICL8	10000	3300	55~115	112~212	84~167	230	186	155	12	3	67	142	47	0.241	268	60	
GIICL9	16000	3000	60~135	142~252	107~202	256	212	180	12	3	69	146	47	0.470	310	96	
GIICL10	22400	2650	65~150	142~252	107~202	287	239	200	14	3.5	78	164	47	0.745	472	119	
GIICL11	35500	2350	70~175	142~302	107~242	352	276	235	14	3.5	81	170	47	1.588	550	189	
GIICL12	50000	2100	75~200	142~352	107~282	362	313	270	16	4	89	190	49	3.055	695	285	
GIICL13	71000	1850	150~225	252~352	202~282	412	350	300	18	4.5	98	208	49	4.918	1019	360	
GIICL14	112000	1650	170~250	302~410	242~330	462	418	335	22	5.5	172	296	63	9.725	3900	544	
GIICL15	180000	1500	190~285	352~470	282~380	512	465	380	22	5.5	182	316	63	17.45	3700	786	
GIICL16	250000	1300	220~320	352~470	282~380	580	522	430	28	7	209	354	67	29.1	4500	1027	
GIICL17	355000	1200	250~365	410~550	330~450	644	582	490	28	7	198	364	67	53.725	4900	1532	
GIICL18	500000	1050	280~400	470~650	380~540	726	654	540	28	8	222	430	75	99.500	7000	2278	
GIICL19	710000	950	300~470	470~650	380~540	818	748	630	32	8	232	440	75	175.5	8900	3026	
GIICL20	1000000	800	360~540	550~800	450~680	928	838	720	32	10.5	247	470	75	360.75	11000	4430	

GIICL G05 Series Taper Bushing Connect Drum Gear Coupling

GIICL6G05—GIICL13G05

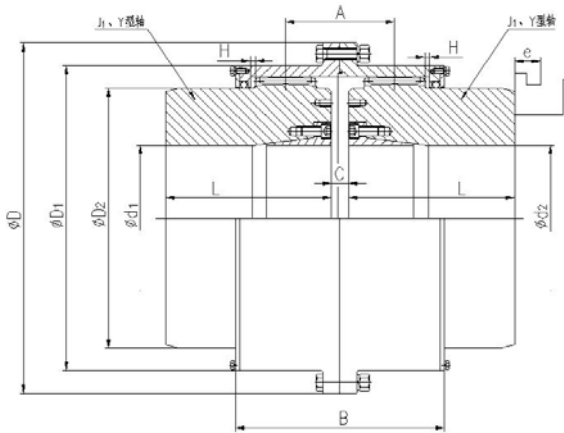

GIICL14G05—GIICL20G05

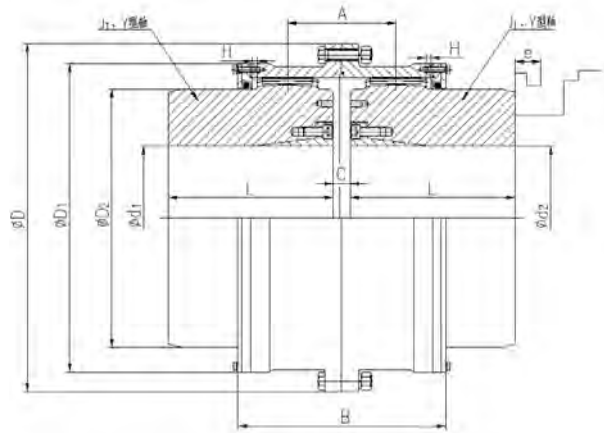

Item No.	Nominal torque Tn	Allow speed n	Shaft hole diameter		Shaft hole length L		D	D ₁	D ₂	C	H	A	B	e	Rotation inertia I	Grease amount	Weight
			d ₁ 、d ₂	Ytype shaft	Jtype shaft												
	N.m	r/min	mm													kg.m ²	ml
GIICL6G05	5000	4000	45~55	112~172	84~132	187	153	125	10	2.5	56	110	42	0.0843	148	31	
GIICL7G05	7100	3750	50~70	112~212	84~167	204	170	140	10	2.5	60	118	42	0.151	175	48	
GIICL8G05	10000	3300	55~75	112~212	84~167	230	186	155	12	3	67	142	47	0.241	268	60	
GIICL9G05	16000	3000	60~95	142~252	107~202	256	212	180	12	3	69	146	47	0.470	310	96	
GIICL10G05	22400	2650	65~100	142~252	107~202	287	239	200	14	3.5	78	164	47	0.745	472	119	
GIICL11G05	35500	2350	80~150	142~302	107~242	352	276	235	14	3.5	81	170	47	1.588	550	189	
GIICL12G05	50000	2100	120~160	142~352	107~282	362	313	270	16	4	89	190	49	3.055	695	285	
GIICL13G05	71000	1850	150~190	252~352	202~282	412	350	300	18	4.5	98	208	49	4.918	1019	360	
GIICL14G05	112000	1650	170~200	302~410	242~330	462	418	335	22	5.5	172	296	63	9.725	3900	544	
GIICL15G05	180000	1500	190~250	352~470	282~380	512	465	380	22	5.5	182	316	63	17.45	3700	786	
GIICL16G05	250000	1300	220~280	352~470	282~380	580	522	430	28	7	209	354	67	29.1	4500	1027	
GIICL17G05	355000	1200	260~320	410~550	330~450	644	582	490	28	7	198	364	67	53.725	4900	1532	
GIICL18G05	500000	1050	300~360	470~650	380~540	726	654	540	28	8	222	430	75	99.500	7000	2278	
GIICL19G05	710000	950	360~420	470~650	380~540	818	748	630	32	8	232	440	75	175.5	8900	3026	
GIICL20G05	1000000	800	420~500	550~800	450~680	928	838	720	32	10.5	247	470	75	360.75	11000	4430	

Coupling Bore Type and Connection Type

Coupling Bore Type And Its Code

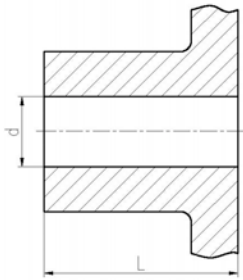

Y Type:Cylindrical Bore

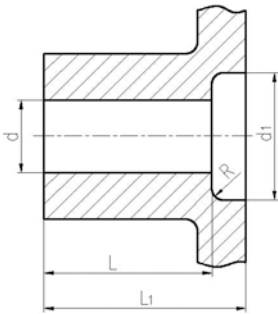

J Type:Cylindrical Bore with Counterbore

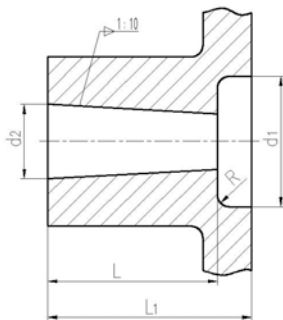

Z Type:Long Taper Bore with Counterbore

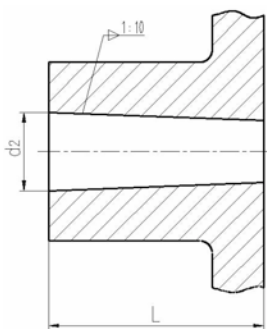

Z1 Type:Long Taper Bore

Connection Type And Its Code

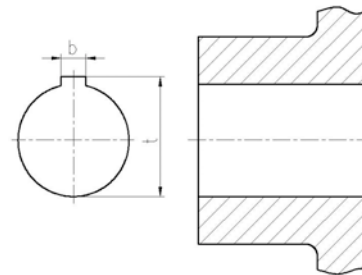

A Type:Single Parallel Keyway

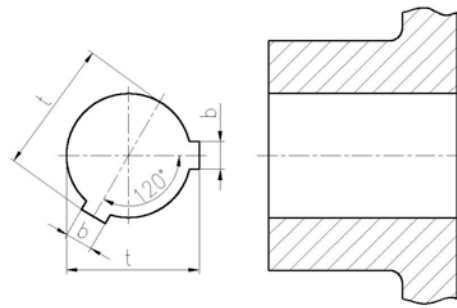

B Type:120° Double Parallel Keyway

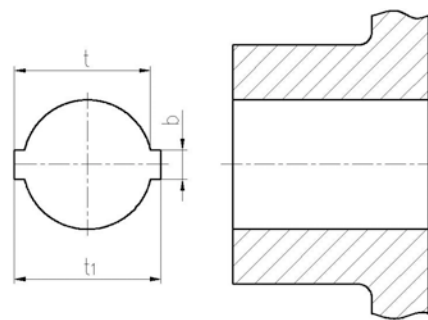

B1 Type:180 Double Parallel Keyway

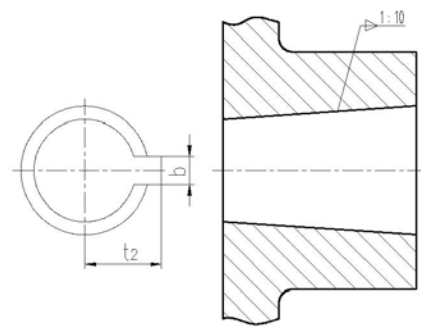

C Type:Long Taper Bore Single Parallel Keyway

Coupling Model Selection Procedure

Step 1: Calculate needed torque, calculated torque is less than or equal to nominal torque of coupling.

$$T_c = K \times T \leq T_n, \quad T = 9550 \times \frac{P_w}{n}$$

In the formula: T_c —calculated torque (N.m) T —working torque (N.m)
 T_n —coupling nominal torque (N.m) K —working condition coefficient of application
 P_w —drive power (Kw) n —working speed (rpm)

Step 2: Speed selection, actual working speed should be less than or equal to allowable speed of coupling, that is $n \leq [n]$

Step 3: Selection according to shaft diameter, actual working shaft diameter should be less than or equal to maximum bore diameter of coupling, that is $d \leq d_{max}$

Step 4: Selection of mounting clearance and dimension, enough mounting space should be guaranteed.

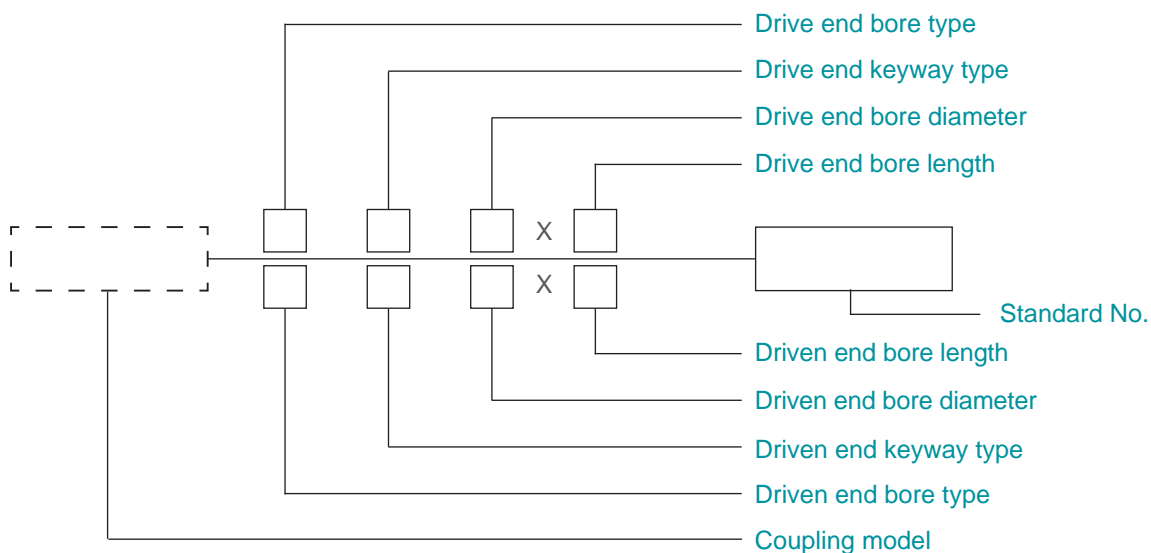

1180G10 Grid Coupling	
Drive end :	Y type bore, A type keyway, d=240, L=270
Driven end:	Y type bore, B type keyway, d=260, L=280
1180G10	$\frac{240 \times 270}{YB260 \times 280}$

Note: Hydraulic Series Coupling doesn't have keyway. Only provide fitting key based on model selection notation

Features of DSN Backstop

- ◆ **Easy Installation** The Backstop is axially symmetrical. Its installation is convenient according to rotation direction.
- ◆ **Reliable Lubrication**
 - a. **Unique sealing design:**

Using dual lipped seals and ring to seal. Dual lipped seals can effectively avoid internal oil leakage. Dust ring can prevent outside dust from contacting oil seal to provide prolonged life in hostile environments.
 - b. **Thorough system design:**

Inner cam can rotate freely with shaft. Contact-sealed splash circulation can lubricate and protect work piece and minimize wear and tear. Multiple oil drain plug can ensure the installation of backstop be mounted at any desired angle. Filtered breather, oil sight gauge and purgeable grease-cavities provide a complete self-lubricating system, which shortens maintenance time.
- ◆ **Longer Service Life** Unique design of cylindrical rollers and wedge action weaken the backstopping contact stress, which increase life.



Typical Application Pattern of Backstop

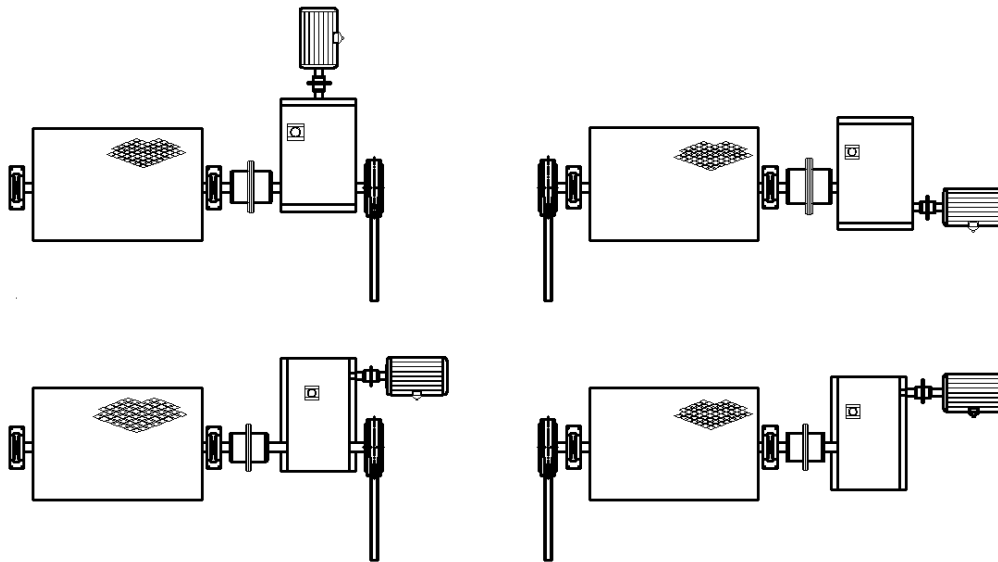

Figure 1: Sole-drive, sole-backstop

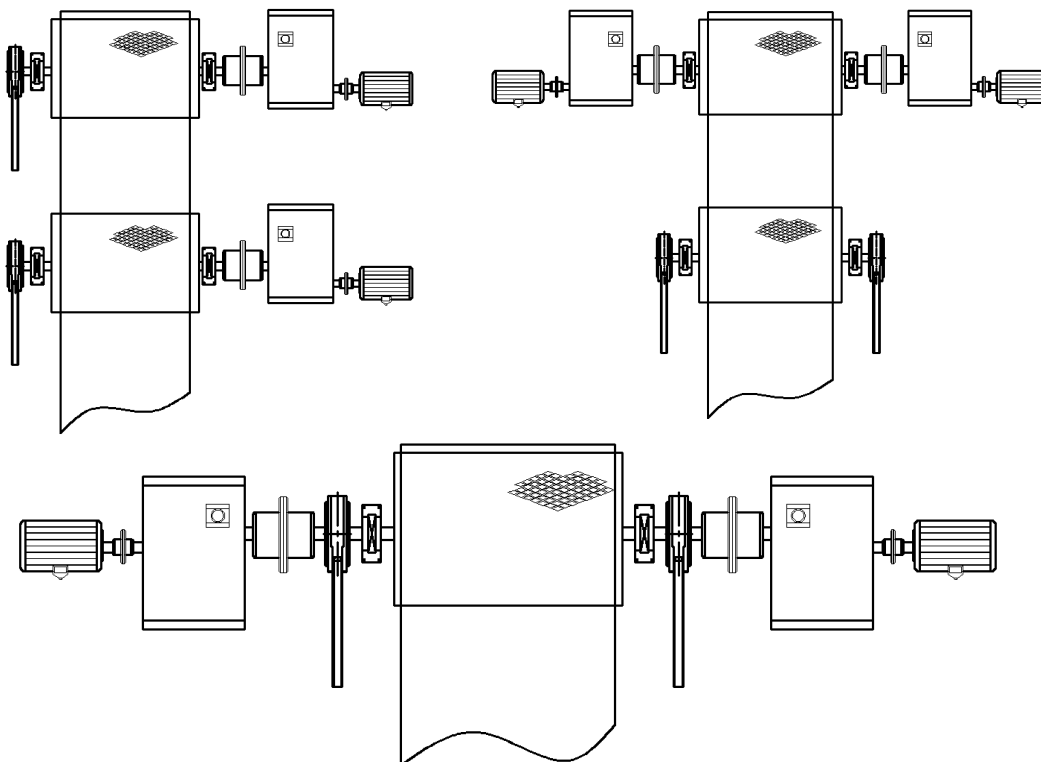

Figure 2: Dual-drive, two backstops

Model Selection Instruction

$$T_c = 9550 \times \frac{P}{n} \times f \leq T_n$$

In formula: T_c —calculated torque (N.m), that is, maximum torque backstop needs to bear.

P — Power (KW)

n — Rotation speed of low speed shaft where backstop is installed

f — working condition factor (take 1.5 when activated 1~3 times a day, take 2 when activated over 3 times a day.

T_n — Nominal torque (N.m)

The Composition of Model Number

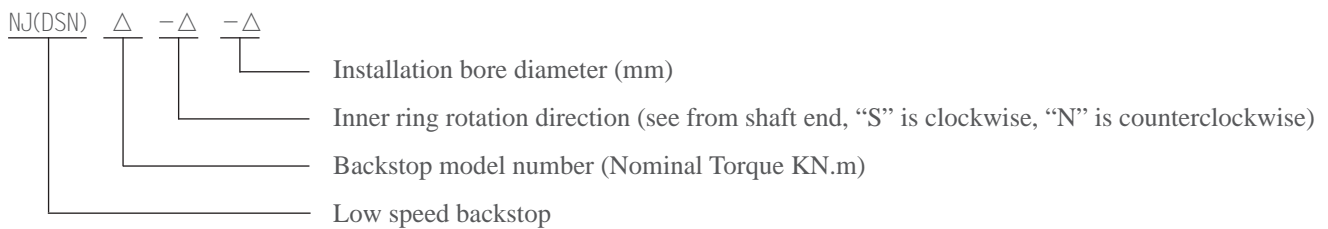

i.e.:

NJ(DSN)530-S-350 means low speed backstop whose nominal torque is 530000N.m, inner ring rotates clockwise, and installation bore diameter is 350mm.

Technical Parameters

Model	Nominal Torque N.m	Max.Inner Ring Rotation Speed r/min	Resistance Torque without load N.m	Max.Bore Diameter mm	Max.Weight Kg
NJ(DSN)25	25000	150	32	Φ160	112
NJ(DSN)38	38000	150	40	Φ200	182
NJ(DSN)50	50000	100	68	Φ220	354
NJ(DSN)90	90000	100	86	Φ250	644
NJ(DSN)130	130000	90	95	Φ270	755
NJ(DSN)200	200000	90	100	Φ300	1088
NJ(DSN)280	280000	90	128	Φ320	1426
NJ(DSN)330	330000	80	145	Φ350	1921
NJ(DSN)530	530000	80	200	Φ420	2945
NJ(DSN)710	710000	80	225	Φ450	3518
NJ(DSN)1000	1000000	70	258	Φ510	4442
NJ(DSN)1300	1300000	60	330	Φ540	5213
NJ(DSN)1700	1700000	50	420	Φ620	7005

Dimensions for Installation Unit: mm

Model	A	B	C	D	E	F	H	h	L
NJ(DSN)25	-	140	80	360	-	-	800	-	150
NJ(DSN)38	-	160	88	430	-	-	850	-	160
NJ(DSN)50	-	200	102	500	-	-	1000	-	240
NJ(DSN)90	-	250	118	600	-	-	1200	-	290
NJ(DSN)130	40	280	122	650	120	60	1100	80	290
NJ(DSN)200	45	320	130	760	135	60	1300	80	290
NJ(DSN)280	50	360	140	850	150	70	1500	100	320
NJ(DSN)330	55	400	142	920	160	70	1600	100	360
NJ(DSN)530	60	450	150	1030	180	80	1800	120	450
NJ(DSN)710	70	500	160	1090	210	100	2000	120	480
NJ(DSN)1000	80	560	170	1200	230	110	2200	150	500
NJ(DSN)1300	80	630	180	1350	230	110	2400	150	500
NJ(DSN)1700	90	700	180	1500	250	120	2500	180	540

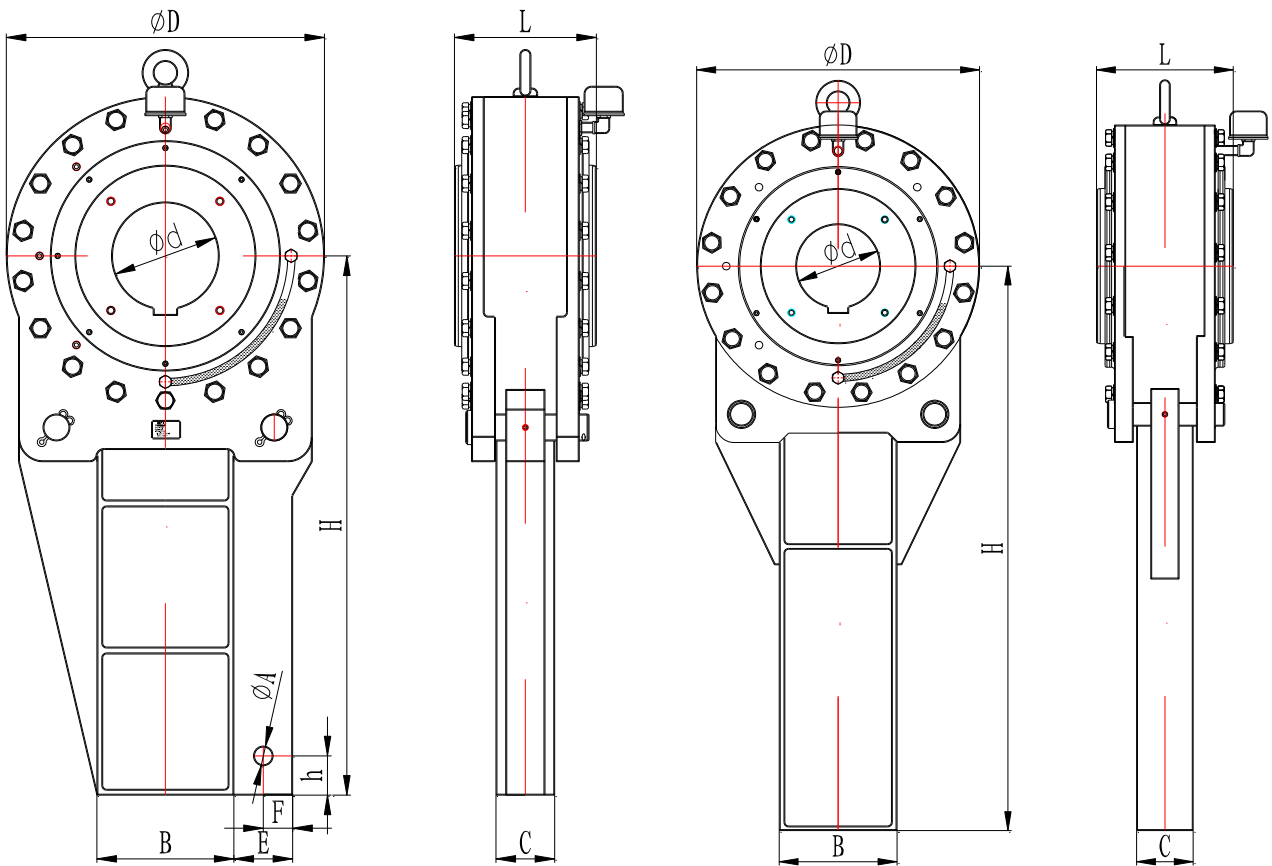

Figure 3

Design and Parameter of Shaft Diameter and Length

The shaft for backstop installation should satisfy the maximum load of backstop. In the table of technical parameters, only maximum bore diameter is specified. Therefore, when choosing small-bore backstop, maximum yield strength of shaft and key should be carefully considered.

Fitting precision of shaft and bore

Shaft Diameter (mm)	Tolerance of Shaft (mm)	Tolerance of bore (mm)	Note
80-120	+0.000 -0.035	+0.036 +0.071	Recommend F7/h7 fitting in standard GB/T1800.4-1999
120-180	+0.000 -0.040	+0.043 +0.083	
180-250	+0.000 -0.046	+0.050 +0.096	
250-315	+0.000 -0.052	+0.056 +0.108	
315-400	+0.000 -0.057	+0.062 +0.119	
400-500	+0.000 -0.063	+0.068 +0.131	

There are two axial positioning modes: 1. shaft-end cover plate positioning; 2. shaft washer position in midst of shaft. When adopting shaft-end cover plate positioning, the minimum shaft length should be between the lengths of L and L1 in Figure 4.

Minimum matching length for bore (Unit: mm)

Model	NJ(DSN)25	NJ(DSN)38	NJ(DSN)50	NJ(DSN)90	NJ(DSN)130	NJ(DSN)200	NJ(DSN)280
L1	120	130	180	220	230	240	260
L	150	160	240	290	290	290	320

Model	NJ(DSN)330	NJ(DSN)530	NJ(DSN)710	NJ(DSN)1000	NJ(DSN)1300	NJ(DSN)1700	
L1	280	380	390	400	410	500	
L	360	450	480	500	500	540	

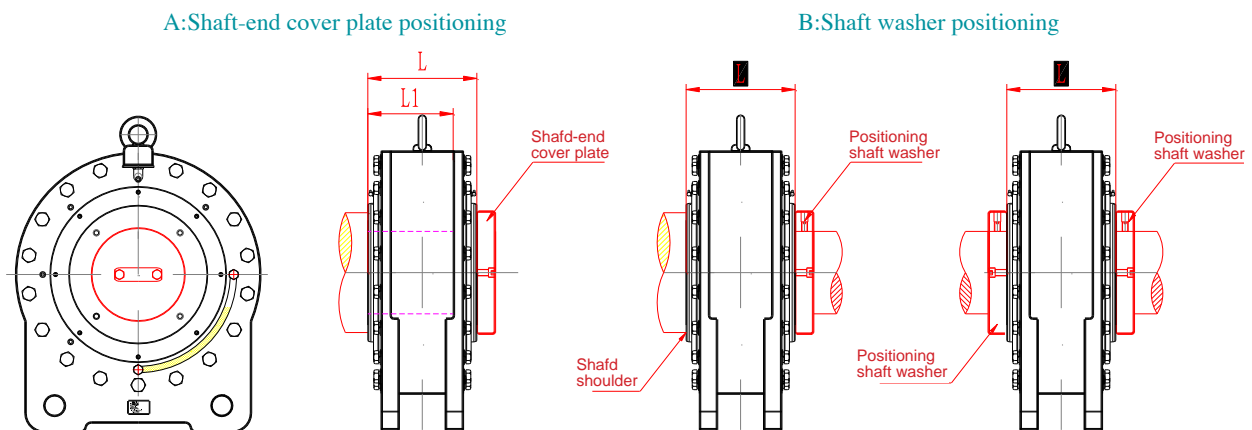

Figure 4: Backstop axial positioning modes

Design and Parameter of the Key on Shaft

Parallel key is used to shaft-bore connection, there should be a gap between the connection lane of backstop inner ring and key, see figure 5. Parallel key should conform to GB/T1096-2003, or be confirmed by customer's requirement.

Notice: it is not allowed to connect with slide groove or wedge-like keys.

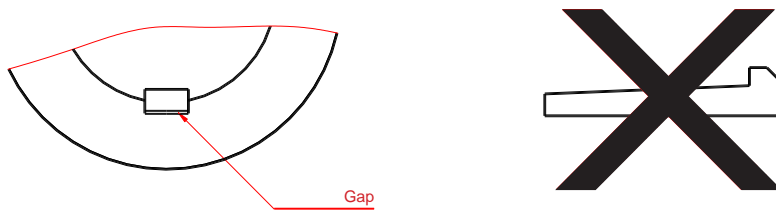

Figure 5

Keyway and tolerance GB/T1095-2003 D10

Unit: mm

Nominal Diameter	Keyway width	Tolerance of Keyway width on bore	Tolerance of Keyway width on bore	Keyway depth on shaft	Keyway depth on bore	Tolerance of Keyway depth
65-75	20	+0.052 +0.000	+0.149 +0.065	7.5	4.9	+0.200 +0.000
75-85	22	+0.052 +0.000	+0.149 +0.065	9	5.4	+0.200 +0.000
85-95	25	+0.052 +0.000	+0.149 +0.065	9	5.4	+0.200 +0.000
95-110	28	+0.052 +0.000	+0.149 +0.065	10	6.4	+0.200 +0.000
110-130	32	+0.062 +0.000	+0.180 +0.080	11	7.4	+0.200 +0.000
130-150	36	+0.062 +0.000	+0.180 +0.080	12	8.4	+0.300 +0.000
150-170	40	+0.062 +0.000	+0.180 +0.080	13	9.4	+0.300 +0.000
170-200	45	+0.062 +0.000	+0.180 +0.080	15	10.4	+0.300 +0.000
200-230	50	+0.062 +0.000	+0.180 +0.080	17	11.4	+0.300 +0.000
230-260	56	+0.074 +0.000	+0.220 +0.100	20	12.4	+0.300 +0.000
260-290	63	+0.074 +0.000	+0.220 +0.100	20	12.4	+0.300 +0.000
290-330	70	+0.074 +0.000	+0.220 +0.100	22	14.4	+0.300 +0.000
330-380	80	+0.074 +0.000	+0.220 +0.100	25	15.4	+0.300 +0.000
380-440	90	+0.087 +0.000	+0.260 +0.120	28	17.4	+0.300 +0.000
440-500	100	+0.087 +0.000	+0.260 +0.120	31	19.5	+0.300 +0.000

Design of Anti-rotation Iron

The anti-rotation iron is used to fix the backstop arm. It must have sufficient anti-shearing (pressure) resistance. The backstop force against the iron varies along with the different length of the arm selected by user.

When the pin hole is installed, the pin hole must be a slot hole, and the direction of the slot hole should be the same as the installation angle of the arm to avoid the radial force borne by outer ring of the backstop. The pin on the iron does not bear force when the backstop is subjected to the backstop force, and its function is anti-rotation during normal operation.

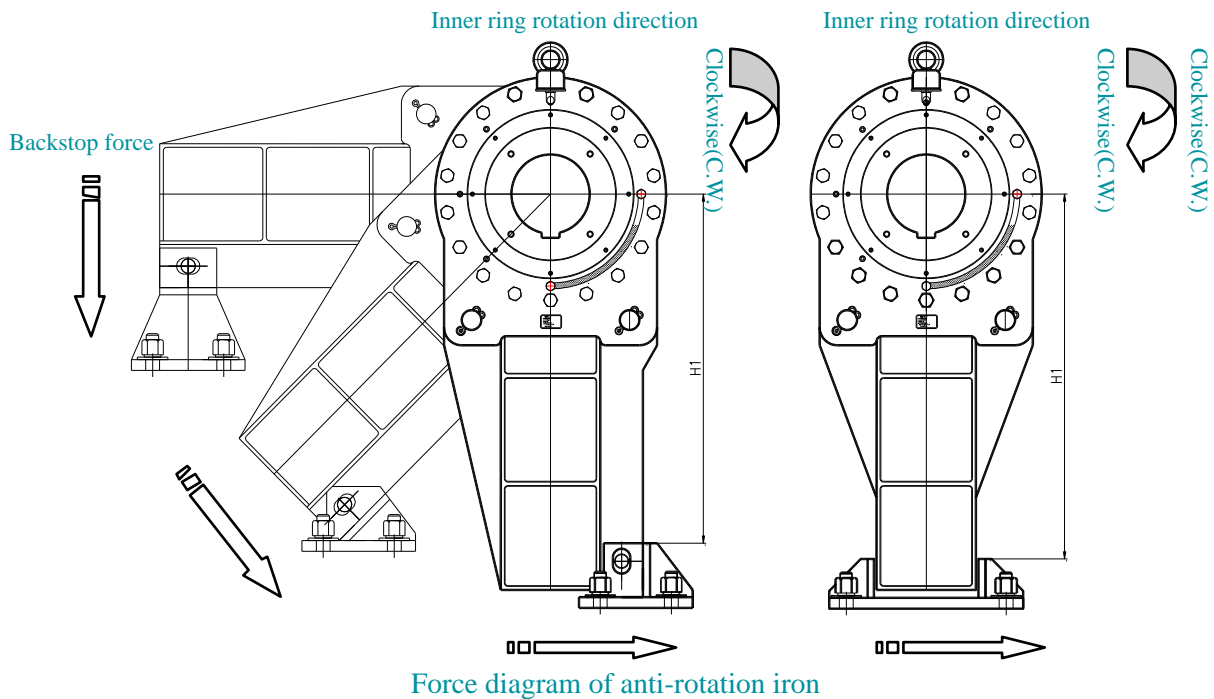

The minimum backstop force against anti-rotation iron when standard arm length is used

Model	Tension length of arm (mm)	Backstop force (N)	Formula
NJ(DSN)25	700	53571	$N = 1.5 \times T_e / H_1$ <p>N—Backstop force of anti-rotation iron (N) T_e—Backstop rated torque(N.m) H₁—Force point of arm to the center of shaft(m)</p>
NJ(DSN)38	750	75999	
NJ(DSN)50	880	102272	
NJ(DSN)90	1080	129807	
NJ(DSN)130	940	207446	
NJ(DSN)200	1140	263157	
NJ(DSN)280	1300	323076	
NJ(DSN)330	1400	353571	
NJ(DSN)530	1560	509615	
NJ(DSN)710	1760	605113	
NJ(DSN)1000	1900	789473	
NJ(DSN)1300	2100	928571	
NJ(DSN)1700	2140	1191588	

Typical arrangement of backstop and anti-rotation

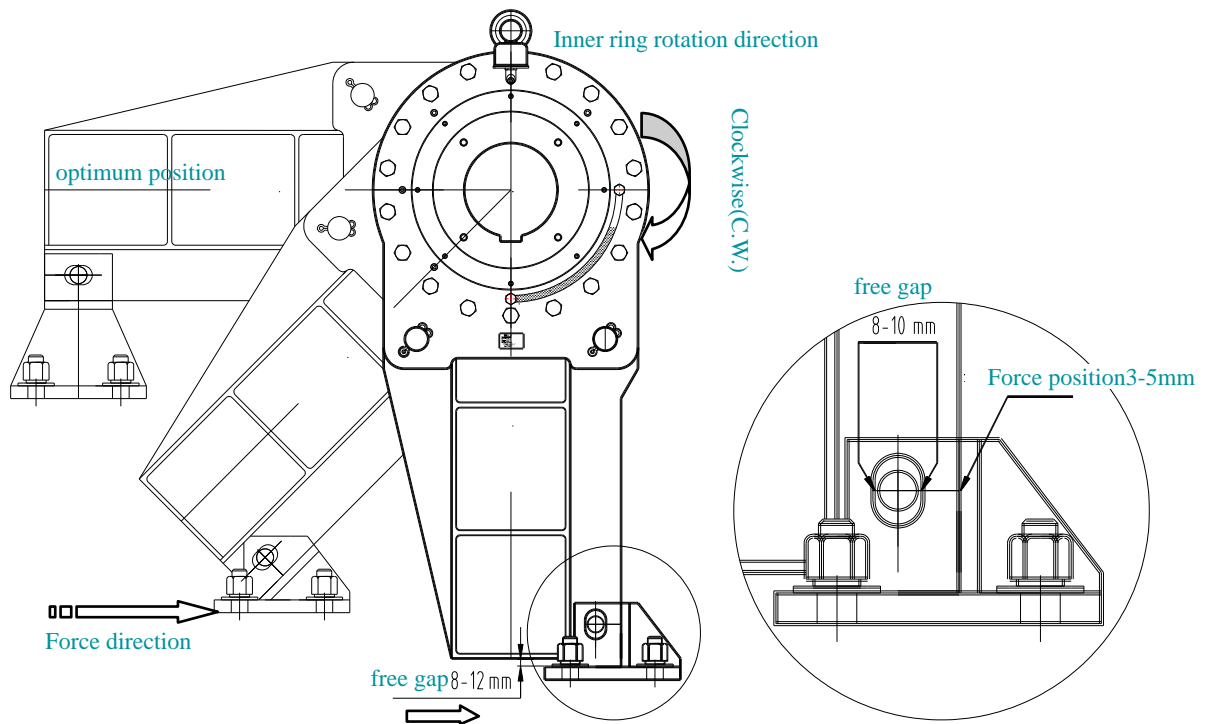

Gap: Recommended space between the bottom of the backstop arm and the upper plane of the anti-rotation iron is 8~12mm.

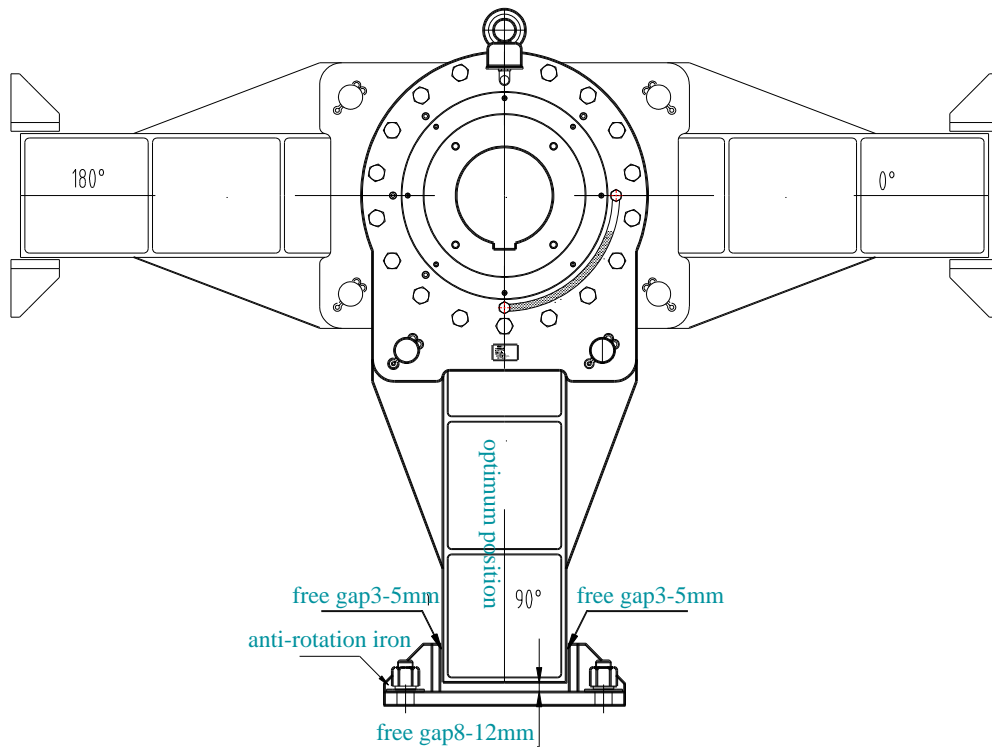

Gap: Recommended space between the bottom of the backstop arm and the upper plane of the anti-rotation iron is 8~12mm.

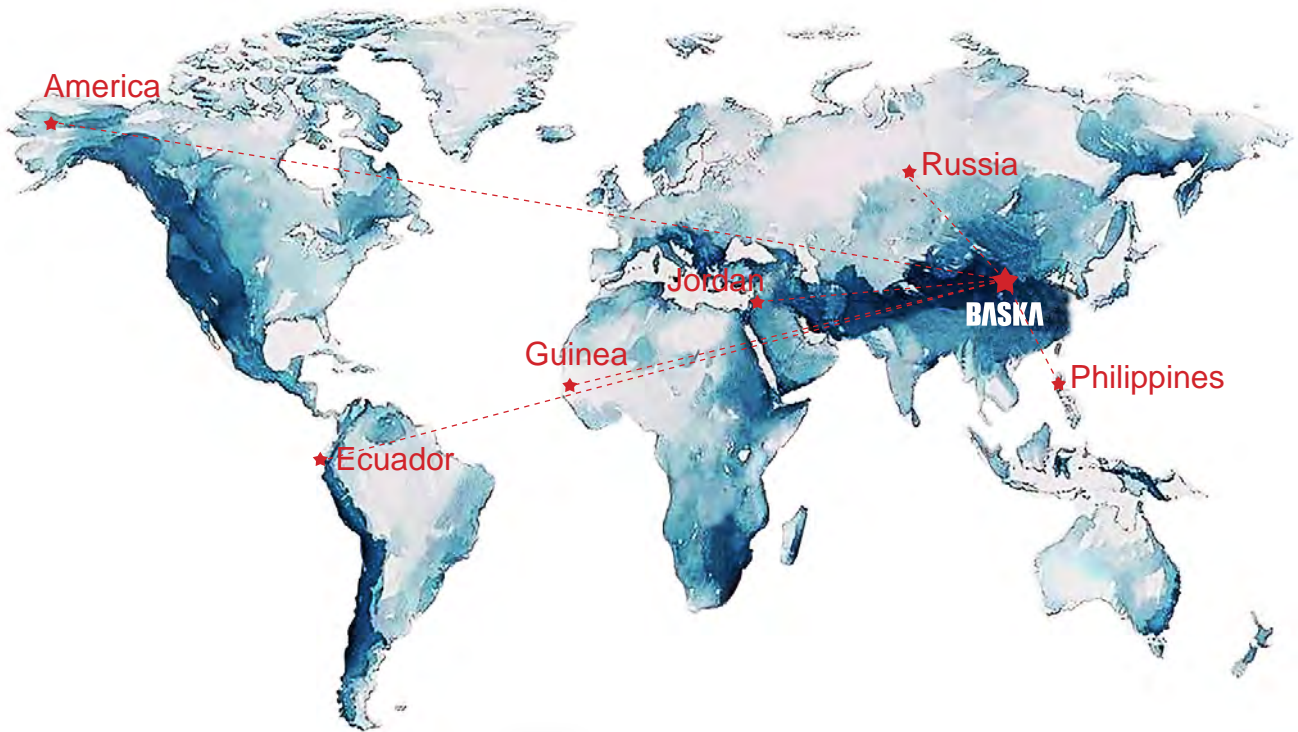

Our company has a professional technical engineer team who is responsible for customer service such as pre-sales technology promotion and after-sale technical support. We adhere to the concept of "invisible service is our competitiveness", and wholeheartedly provide you with a systematic solution for your transmission problem.

Technical Agreement of Coupling (Appendix to Contract)

Purchaser: _____

Supplier: Beijing Baska Technology Co., Ltd.

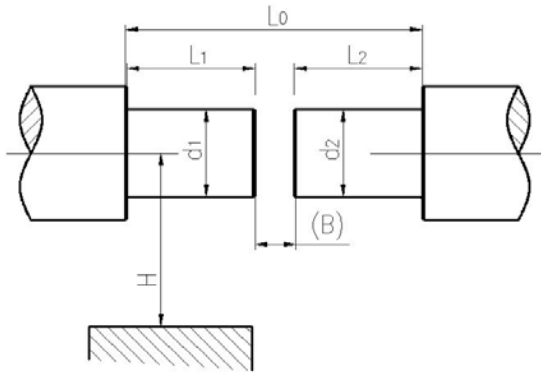

1. Application to: e.g. conveyor, crusher, compressor, etc.

2. Driving end related parameters:

Motor power(KW): _____

Motor rotation speed(rpm): _____

Reducer speed ratio: _____

3. Notice:

a. Default tolerance of cylindrical shaft diameter is m6;

b. Default keyway of cylindrical shaft is conformed with GB/T 1095-2003

For cylindrical shaft, please provide:

Shaft end gap length B(mm): _____

Center height H(mm): _____

High speed shaft:

Driving end: shaft diameter d1(mm) _____

shaft length L1(mm) _____

key groove width b(mm) _____

key groove depth t(mm) _____

Driven end: shaft diameter d2(mm) _____

shaft length L2(mm) _____

key groove width b(mm) _____

key groove depth t(mm) _____

Low speed shaft:

Driving end: shaft diameter d1(mm) _____

shaft length L1(mm) _____

key groove width b(mm) _____

key groove depth t(mm) _____

Driven end: shaft diameter d2(mm) _____

shaft length L2(mm) _____

key groove width b(mm) _____

key groove depth t(mm) _____

The selected coupling model:

Quantity (Set):

Coupling hub length: a. standard length

b. shaft length

Delivery time

Delivery address:

Purchaser:

Supplier: Beijing Baska Tech. Co.,Ltd

Representative (signature):

Representative (signature):

Signing date:

Signing date:

Tel/Fax:

Tel:+86 4001166012

Email:

Email: info@baska.com

Technical Agreement of Coupling (Appendix to Contract)

Purchaser: _____

Supplier: Beijing Baska Technology Co., Ltd.

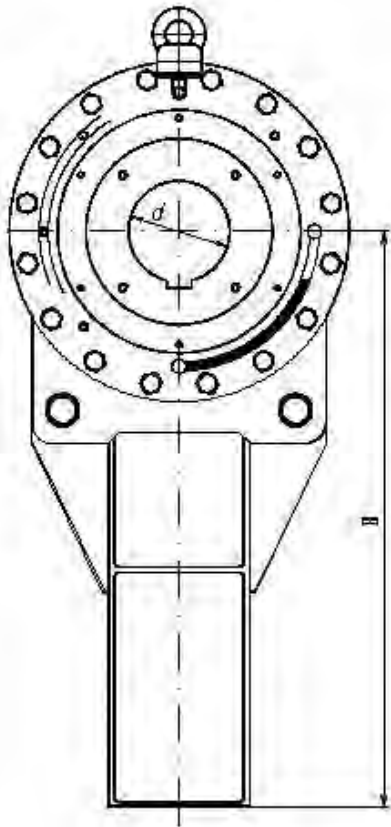

Backstop Parameters:

Torque (N•m): _____

Rotating direction: _____

Center height H(mm): _____

Installation method:

- a. arm of force has a pinhole
- b. arm of force has no pinhole

Installation angle:

- a. horizontal
- b. vertical
- c. 45 degree
- d. other (please provide inclination angle and direction)

Installation parameters:

Shaft diameter d(mm): _____

Tolerance: _____

Key groove width b(mm): _____

Key groove depth t(mm): _____

Shaft length(mm): _____

Inner race length (L):

- a. The same as standard
- b. The same as shaft length

Delivery time

Delivery address:

Purchaser:

Representative (signature):

Signing date:

Tel/Fax:

Email:

Supplier: Beijing Baska Tech. Co.,Ltd

Representative (signature):

Signing date:

Tel:+86 4001166012

Email: info@baska.com



Distributors for Australia & New Zealand MOTION TECHNOLOGIES PTY LIMITED

24/22-30 Northumberland Road
Caringbah NSW 2229 Australia
Phone: (02) 9524 4782

sales@motiontech.com.au
www.motiontech.com.au

© 20/09/2022

BASKA

北京巴什卡科技有限公司
BEIJING BASKA TECHNOLOGY CO.,LTD

Address: Floor 16th, Build #2, Longqi Square, Xisanqi,
Haidian District, Beijing, China.

Tel: +86 4001166012
Fax: +86 10 82694464
Email: info@baska.com
Web: www.baska.com

Copyright by Beijing Baska Technology Co., Ltd.

