

Drive Slew Rings for actuation of Solar and Photovoltaic panels

Both slew and worm products are designed and tested beyond the customer's static and dynamic loading scenarios to ensure that your system maintains optimized functionality for maximum power generation. Motion Technologies offers a range of both standard and custom solutions to suit the PV and CSP Tracking industry including high efficiency AC and DC electric motors and drives to suit any system controller.

Application examples:

- ✚ Solar Power Tower
- ✚ Concentrated Solar Thermal
- ✚ Solar Parabolic Trough
- ✚ Solar Dish
- ✚ Linear Fresnel Solar Concentrator
- ✚ Single-Axis Solar Tracking
- ✚ Dual-Axis Solar Tracking
- ✚ Linked Horizontal Single-Axis Tracking
- ✚ Centralized & Decentralized Single-Axis Tracking
- ✚ Utility-Scale & Distributed Solar Tracking

The following pages show standard products which can be customised to suit any specific application or installation by utilising:

- ✚ Gated product development processes
- ✚ Specification development
- ✚ 3D & 2D design
- ✚ Simulation, FEA
- ✚ Engineering analysis, DFMEA
- ✚ Prototyping
- ✚ Custom test design & design verification
- ✚ Custom manufacturing



SLEWING DRIVE 回转式减速器

VE5D

UNITS: mm
单位: mm
1inch=25.4mm

Weight: 35kg



Slewing Drive Performance Parameters

VE5D性能参数表

Rated Output Torque	Output Torque (Max.)	Holding Torque	Gear Ratio	Tracking Precision	Weight
额定输出转矩	最大输出转矩	保持力矩	减速比	精度等级	重量
3300 N.m	4.8 kN.m	15 kN.m	55 : 1	≤0.3°	35 kg (SS113)
2435 lbf.ft	3542 lbf.ft	3066 lbf.ft			

TOP VIEW
俯视图

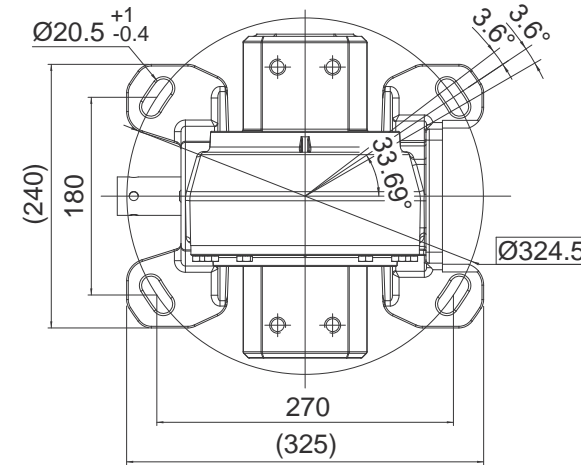

VIEW A
A向视图

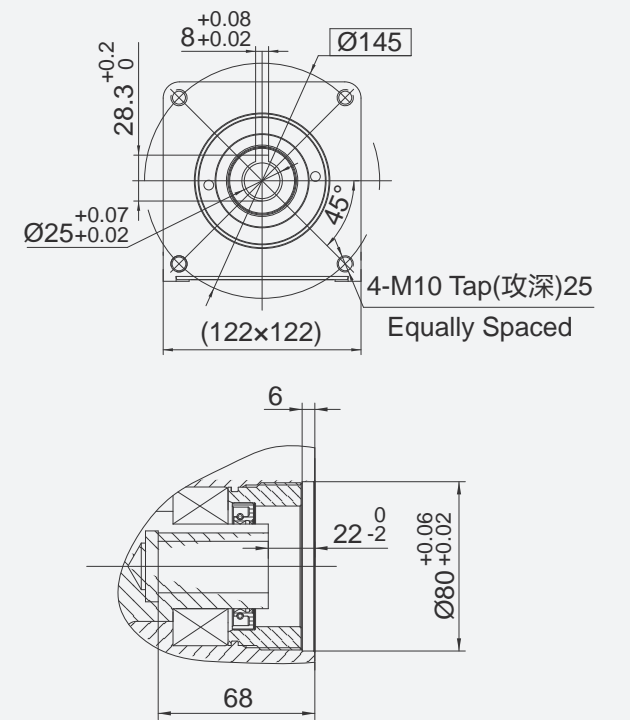

FRONT VIEW (R101)
正视图

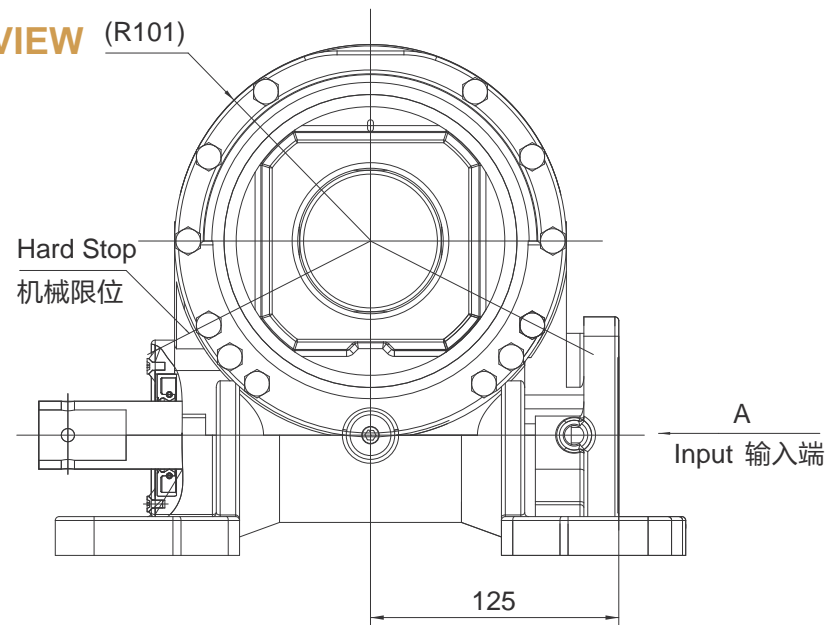

SIDE VIEW
侧视图

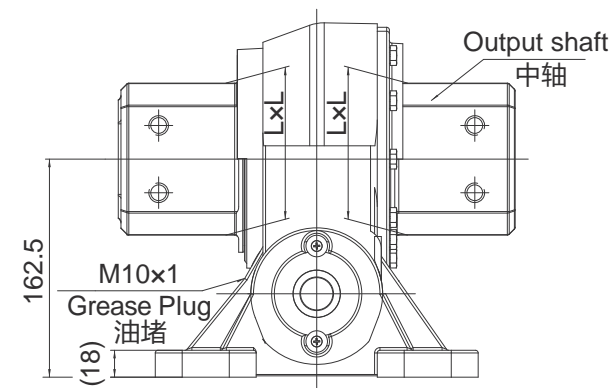

Type of output shaft	Square 方形(max.)
中轴类型	SS113
Size 尺寸(LxL)	113x113

中轴类型、尺寸可根据客户要求, 进行非标设计(Customized)

NOTICE 注意

- This drawing is just for your reference. 以上图纸仅供参考。
- This drawing is subject to change due to new design without prior notice. 本公司保留改进产品的权利而不再另行通知。

SPECIAL DESIGN BASE ON CUSTOMER'S REQUIREMENT
可根据顾客的要求进行非标设计

SLEWING DRIVE 回转式减速器

VE6D

UNITS: mm
单位: mm
1inch=25.4mm

Weight: 33kg



Slewing Drive Performance Parameters

VE6D性能参数表

Rated Output Torque	Output Torque (Max.)	Holding Torque	Gear Ratio	Tracking Precision	Weight
额定输出转矩	最大输出转矩	保持力矩	减速比	精度等级	重量
4200 N.m	7200 N.m	25 kN.m	55 : 1	≤0.3°	33 kg (SS113)
3099 lbf.ft	5309 lbf.ft	18450 lbf.ft			

TOP VIEW
俯视图

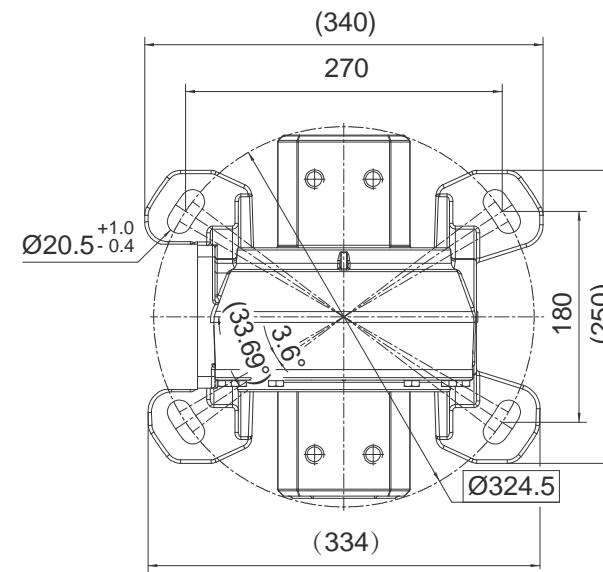

VIEW A
A向视图

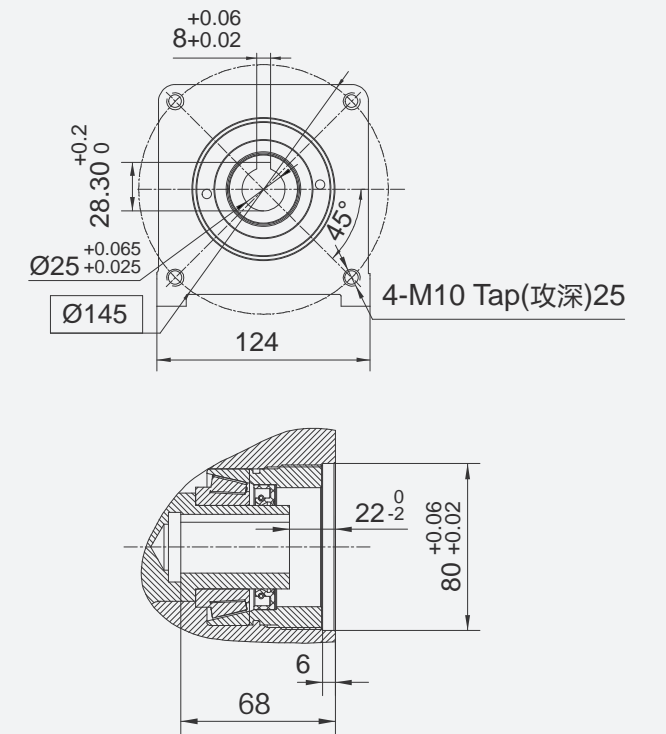

FRONT VIEW
正视图

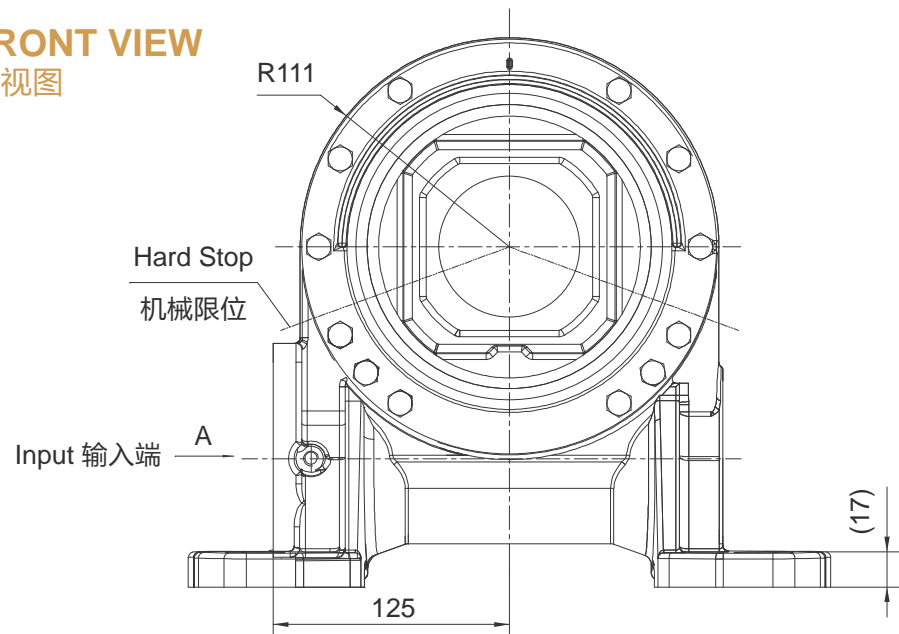

SIDE VIEW
侧视图

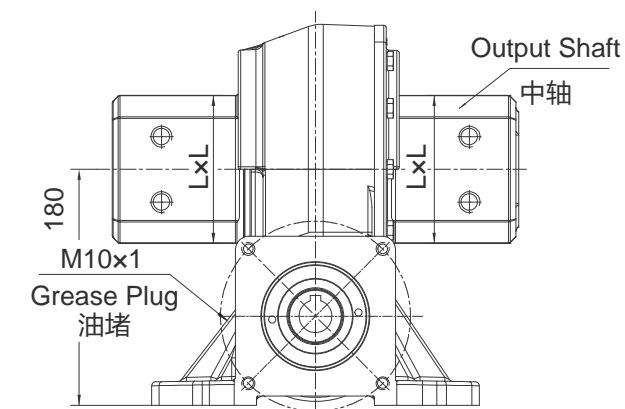

Type of output shaft	Square 方形(max.)
中轴类型	SS113
Size 尺寸(LxL)	113x113

中轴类型、尺寸可根据客户要求, 进行非标设计(Customized)

NOTICE 注意

- This drawing is just for your reference. 以上图纸仅供参考。
- This drawing is subject to change due to new design without prior notice. 本公司保留改进产品的权利而不再另行通知。

SPECIAL DESIGN BASE ON CUSTOMER'S REQUIREMENT
可根据顾客的要求进行非标设计

SLEWING DRIVE 回转式减速器

VE7D

UNITS: mm
单位: mm
1inch=25.4mm

Weight: 40kg

Slewing Drive Performance Parameters

VE7D性能参数表

Rated Output Torque	Output Torque (Max.)	Holding Torque	Gear Ratio	Tracking Precision	Weight
额定输出转矩	最大输出转矩	保持力矩	减速比	精度等级	重量
4500 N.m	8500 N.m	39 kN.m	60 : 1	≤0.3°	40 kg (SS112)
3321 lbf.ft	6273 lbf.ft	28782 lbf.ft			

FRONT VIEW
正视图

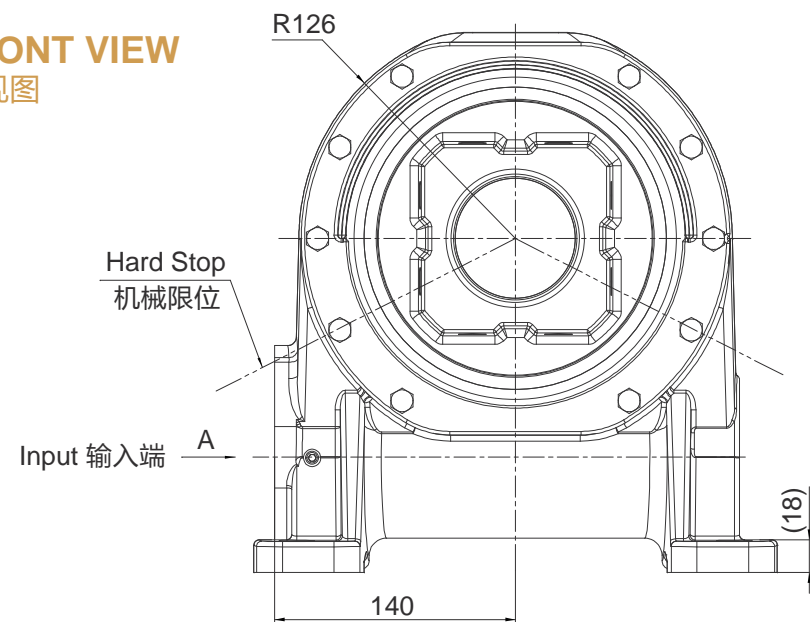

SPECIAL DESIGN BASE ON CUSTOMER'S REQUIREMENT
可根据顾客的要求进行非标设计

TOP VIEW
俯视图

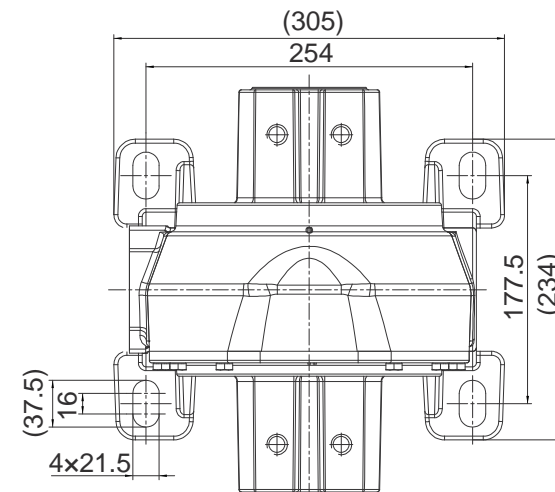

SIDE VIEW
侧视图

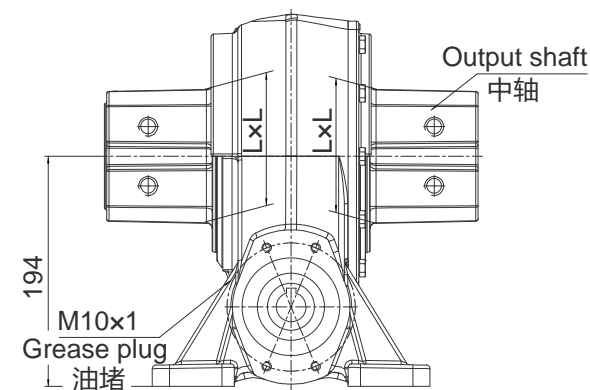

VIEW A
A向视图

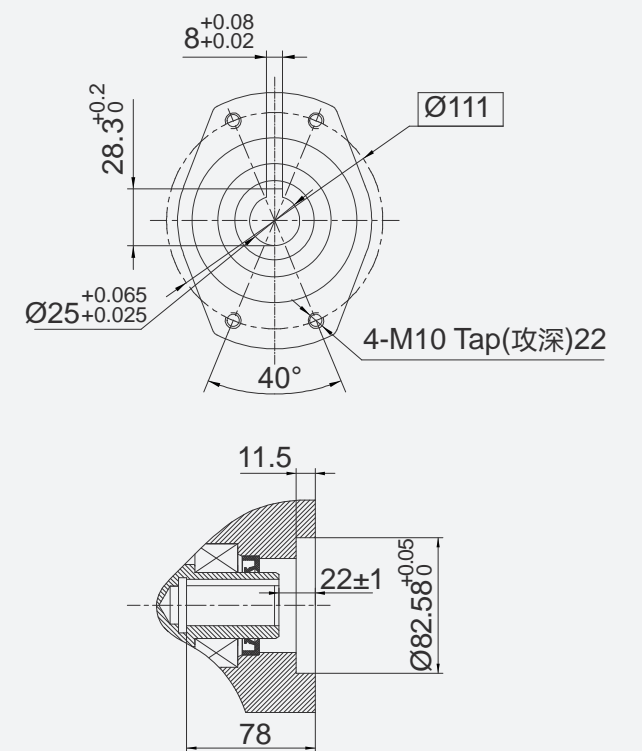

Type of output shaft Square 方形 Square 方形 Square 方形(max.)

中轴类型	SS110	SS111	SS112
Size 尺寸(LxL)	110x110	111x111	112x112

中轴类型、尺寸可根据客户要求, 进行非标设计(Customized)

NOTICE 注意

- This drawing is just for your reference. 以上图纸仅供参考。
- This drawing is subject to change due to new design without prior notice. 本公司保留改进产品的权利而不再另行通知。

SLEWING DRIVE (Active drive) 回转式减速器 (主动)

VE7DC

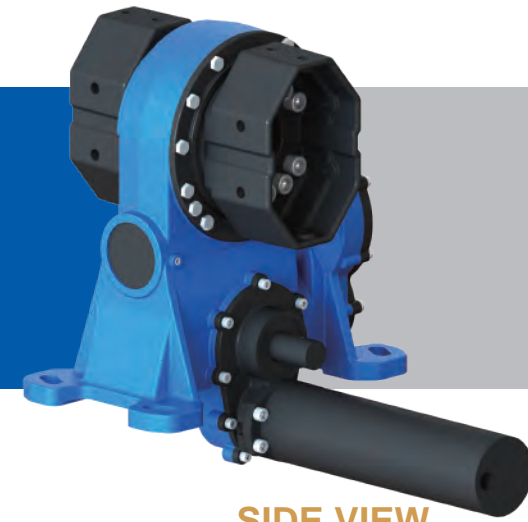

UNITS: mm
单位: mm
1inch=25.4mm

Weight: 73kg

Slewing Drive Performance Parameters
VE7DC (主动) 性能参数表

Rated Output Torque	Output Torque (Max.)	Holding Torque	Gear Ratio	Tracking Precision	Weight
额定输出转矩	最大输出转矩	保持力矩	减速比	精度等级	重量
2500 N.m	8500 N.m	41kN.m	288 : 1	≤0.3°	≈73 kg (OC226×158)
1845 lbf.ft	6273 lbf.ft	30258 lbf.ft			

FRONT VIEW
正视图

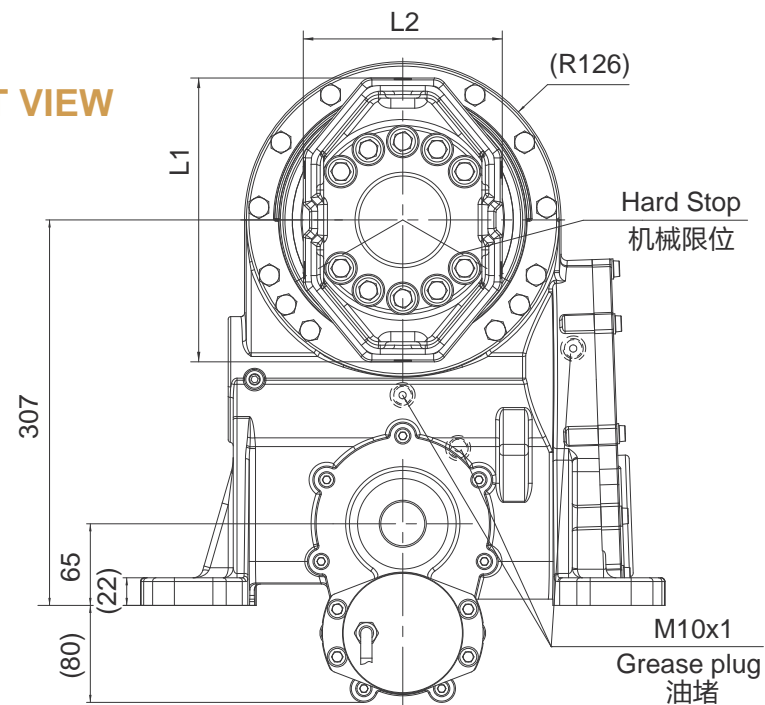

SPECIAL DESIGN BASE ON CUSTOMER'S REQUIREMENT
可根据顾客的要求进行非标设计

TOP VIEW
俯视图

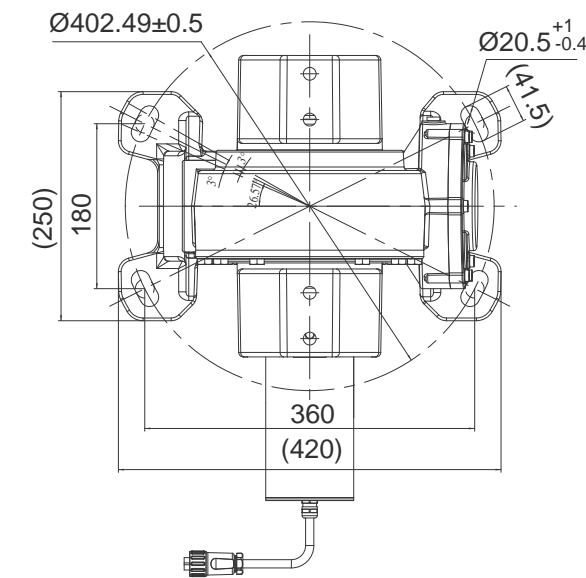

SIDE VIEW
侧视图

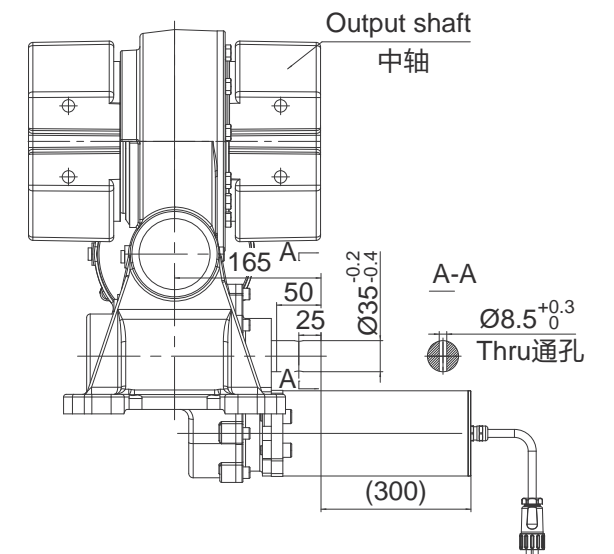

24VDC Planetary Reducer Motor Performance Data
24.30.200 直流有刷减速电机性能参数

Rated Voltage	Rated Speed	Rated Torque	Rated Current	IP Class
额定电压	额定转速	额定转矩	额定电流	防护等级
24 VDC	3 rpm	200N.m	≤7 A	IP65

One motor can drive two slewing drives. 一台电机可以驱动两台装置

Type of output shaft Octagon 八边形(max.)

中轴类型 OC226×158

Size 尺寸(L1×L2) 226×158

中轴类型、尺寸可根据客户要求, 进行非标设计(Customized)

NOTICE 注意

- This drawing is just for your reference. 以上图纸仅供参考。
- This drawing is subject to change due to new design without prior notice. 本公司保留改进产品的权利而不再另行通知。

SLEWING DRIVE (Passive drive) 回转式减速器 (从动)

VE7DC



UNITS: mm
单位: mm
1inch=25.4mm

Weight: 65kg

Slewing Drive Performance Parameters
VE7DC (从动) 性能参数表

Rated Output Torque	Output Torque (Max.)	Holding Torque	Gear Ratio	Tracking Precision	Weight
额定输出转矩	最大输出转矩	保持力矩	减速比	精度等级	重量
2500 N.m	8500 N.m	41kN.m	158.28 : 1	≤0.3°	≈65 kg (OC226×158)
1845 lbf.ft	6273 lbf.ft	30258 lbf.ft			

FRONT VIEW
正视图

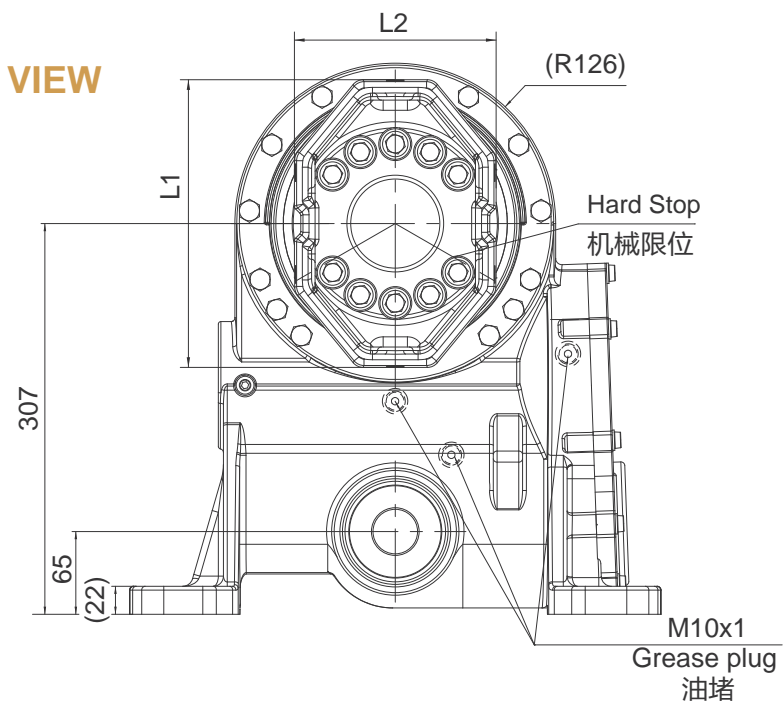

SPECIAL DESIGN BASE ON CUSTOMER'S REQUIREMENT
可根据顾客的要求进行非标设计

TOP VIEW
俯视图

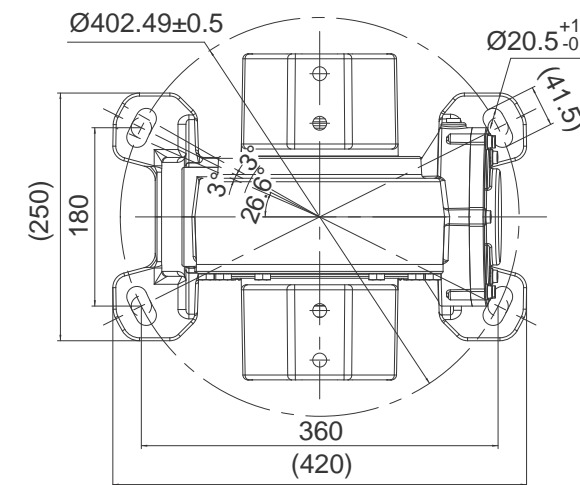

SIDE VIEW
侧视图

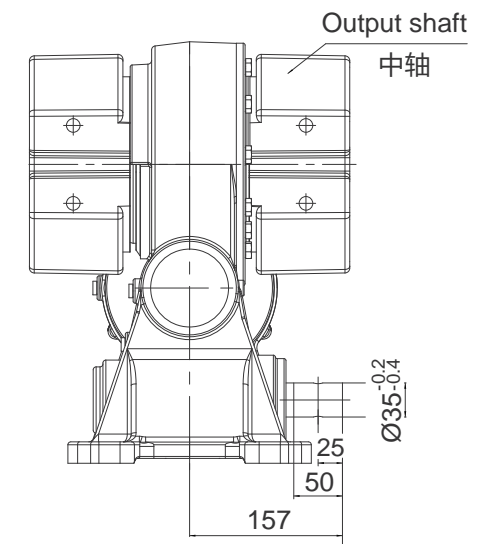

Type of output shaft	Octagon 八边形(max.)
中轴类型	OC226×158
Size 尺寸(L1×L2)	226×158

中轴类型、尺寸可根据客户要求, 进行非标设计(Customized)

NOTICE 注意

- This drawing is just for your refenece.
以上图纸仅供参考。
- This drawing is susbject to change due to new design without prior notice.
本公司保留改进产品的权利而不再另行通知。

SLEWING DRIVE (Active drive) 回转式减速器 (主动)

VE7DF



UNITS: mm
单位: mm
1 inch=25.4mm

Weight: 72kg

Slewing Drive Performance Parameters
VE7DF (主动) 性能参数表

Rated Output Torque	Output Torque (Max.)	Holding Torque	Gear Ratio	Tracking Precision	Weight
额定输出转矩	最大输出转矩	保持力矩	减速比	精度等级	重量
2500 N.m	8500 N.m	41kN.m	158.28 : 1	≤0.3°	≈72 kg (OC226×158)
1845 lbf.ft	6273 lbf.ft	30258 lbf.ft			

TOP VIEW
俯视图

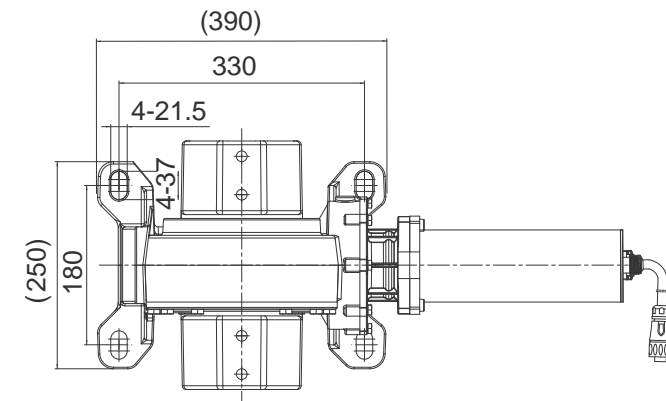

SIDE VIEW
侧视图

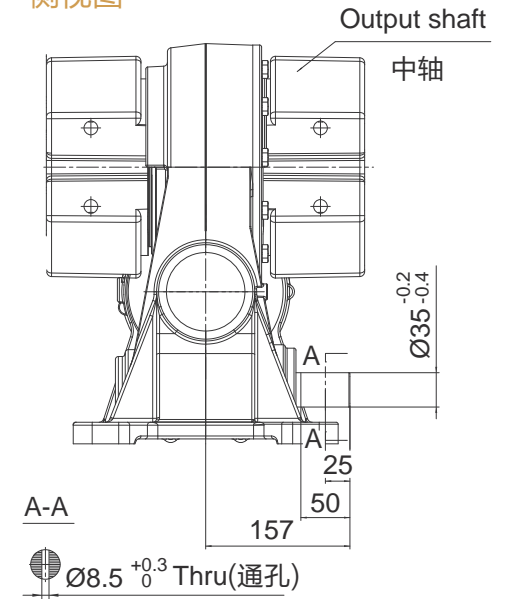

FRONT VIEW
正视图

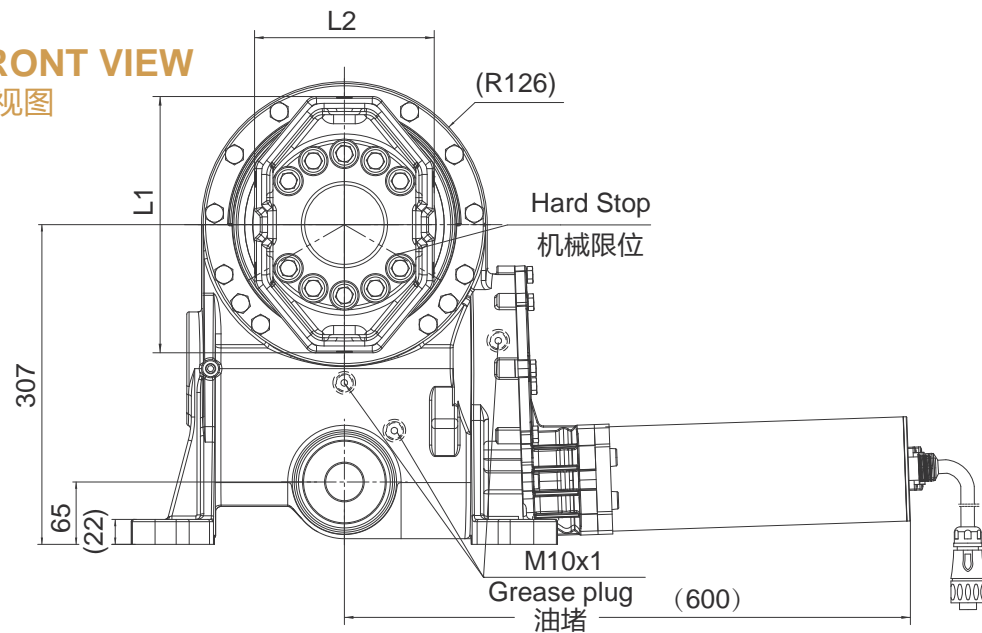

SPECIAL DESIGN BASE ON CUSTOMER'S REQUIREMENT
可根据顾客的要求进行非标设计

24VDC Planetary Reducer Motor Performance Data
24.25.240 直流有刷减速电机性能参数

Rated Voltage	Rated Speed	Rated Torque	Rated Current	IP Class
额定电压	额定转速	额定转矩	额定电流	防护等级
24 VDC	2.5 rpm	240N.m	≤6 A	IP65

One motor can drive two slewing drives. 一台电机可以驱动两台装置

Type of output shaft Octagon 八边形(max.)

中轴类型 OC226×158

Size 尺寸(L1×L2) 226×158

中轴类型、尺寸可根据客户要求, 进行非标设计(Customized)

NOTICE 注意

- This drawing is just for your refenece. 以上图纸仅供参考。
- This drawing is subject to change due to new design without prior notice. 本公司保留改进产品的权利而不再另行通知。

SLEWING DRIVE (Passive drive) 回转式减速器 (从动)

VE7DF



UNITS: mm
单位: mm
1inch=25.4mm

Weight: 65kg

Slewing Drive Performance Parameters
VE7DF (从动) 性能参数表

Rated Output Torque	Output Torque (Max.)	Holding Torque	Gear Ratio	Tracking Precision	Weight
额定输出转矩	最大输出转矩	保持力矩	减速比	精度等级	重量
2500 N.m	8500 N.m	41kN.m	158.28 : 1	≤0.3°	≈65 kg (OC226×158)
1845 lbf.ft	6273 lbf.ft	30258 lbf.ft			

FRONT VIEW
正视图

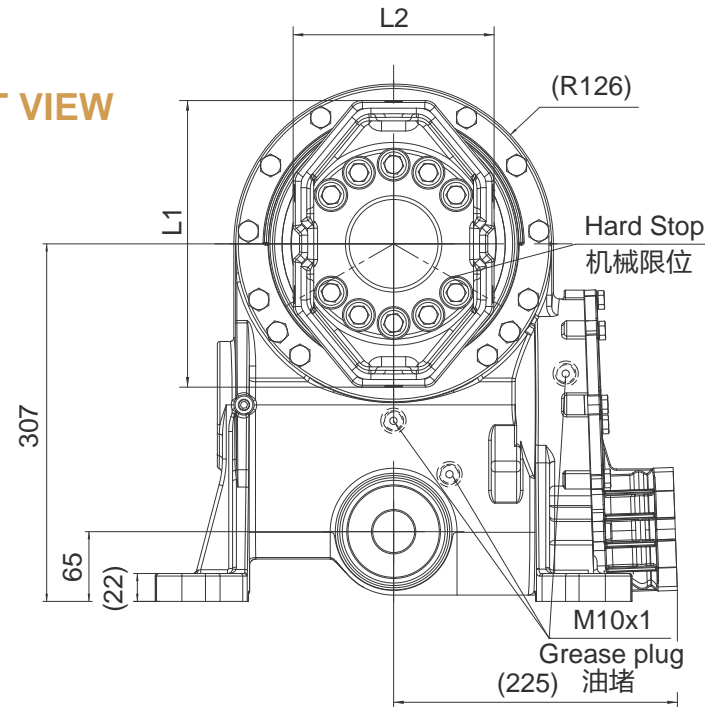

SPECIAL DESIGN BASE ON CUSTOMER'S REQUIREMENT
可根据顾客的要求进行非标设计

TOP VIEW
俯视图

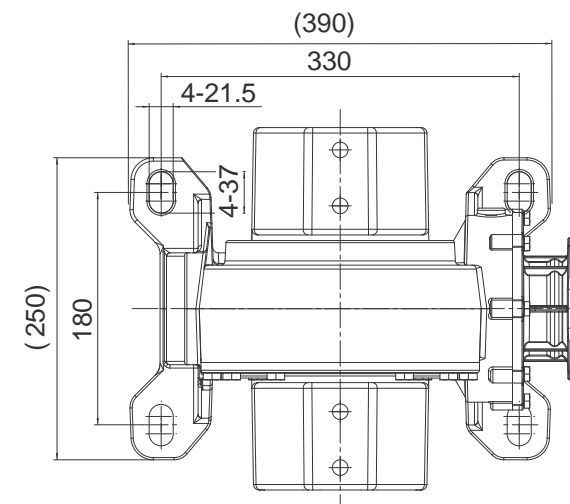

SIDE VIEW
侧视图

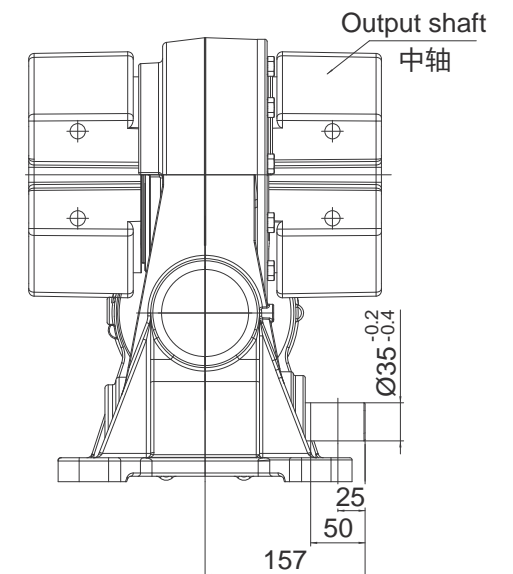

Type of output shaft	Octagon 八边形(max.)
中轴类型	OC226×158
Size 尺寸(L1×L2)	226×158

中轴类型、尺寸可根据客户要求, 进行非标设计(Customized)

NOTICE 注意

- This drawing is just for your refenece. 以上图纸仅供参考。
- This drawing is susbject to change due to new design without prior notice. 本公司保留改进产品的权利而不再另行通知。

SLEWING DRIVE (Active drive) 回转式减速器 (主动)

VE7DP

UNITS: mm
单位: mm
1 inch=25.4mm

Weight: 66kg



Slewing Drive Performance Parameters

VE7DP性能参数表

Rated Output Torque	Output Torque (Max.)	Holding Torque	Gear Ratio	Tracking Precision	Weight
额定输出转矩	最大输出转矩	保持力矩	减速比	精度等级	重量
3500 N.m	7000 N.m	42 kN.m	89.47 : 1	≤0.3°	66 kg (SS134)
2583 lbf.ft	5166 lbf.ft	30996 lbf.ft			

TOP VIEW
俯视图

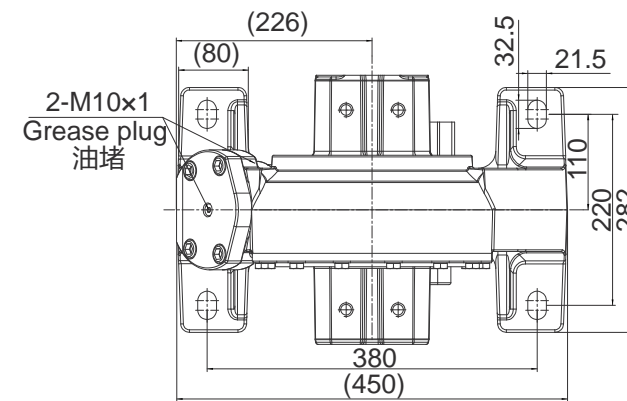

VIEW A
A向视图

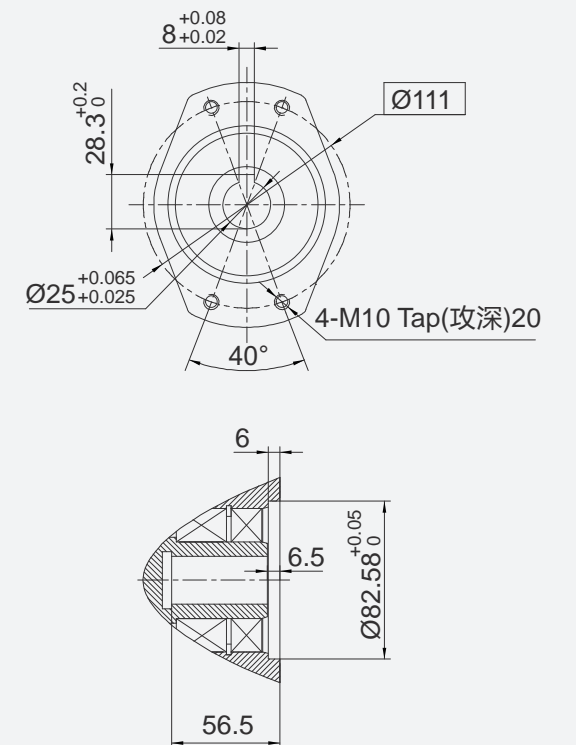

FRONT VIEW
正视图

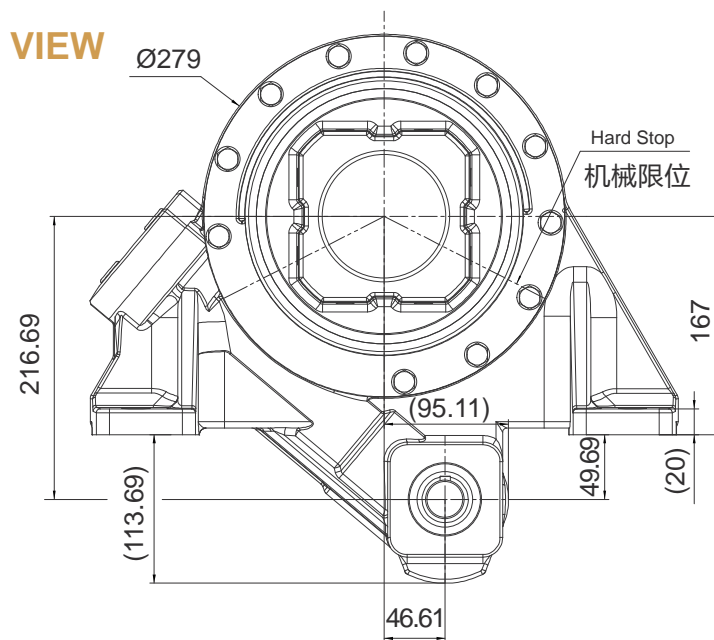

SIDE VIEW
侧视图

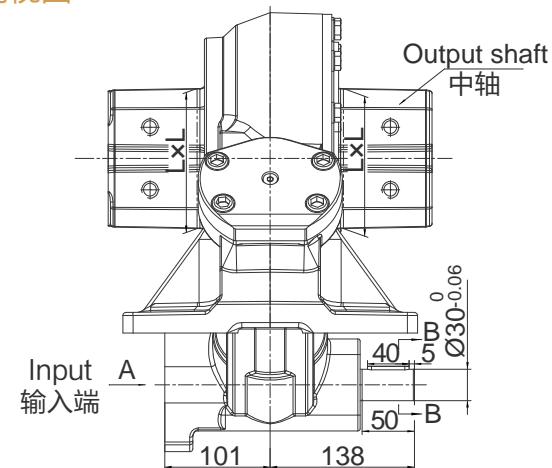

Type of output shaft	Square 方形	Square 方形(max.)
中轴类型	SS130	SS134
Size 尺寸(LxL)	130x130	134x134

中轴类型、尺寸可根据客户要求, 进行非标设计(Customized)

NOTICE 注意

- This drawing is just for your reference. 以上图纸仅供参考。
- This drawing is subject to change due to new design without prior notice. 本公司保留改进产品的权利而不再另行通知。

SPECIAL DESIGN BASE ON CUSTOMER'S REQUIREMENT
可根据顾客的要求进行非标设计

SLEWING DRIVE (Passive drive) 回转式减速器 (从动)

VE7DP

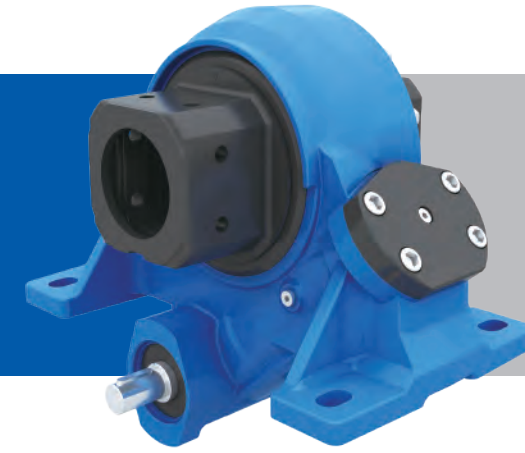

UNITS: mm
单位: mm
1inch=25.4mm

Weight: 66kg

Slewing Drive Performance Parameters

VE7DP性能参数表

Rated Output Torque	Output Torque (Max.)	Holding Torque	Gear Ratio	Tracking Precision	Weight
额定输出转矩	最大输出转矩	保持力矩	减速比	精度等级	重量
3500 N.m	7000 N.m	42 kN.m	89.47 : 1	≤0.3°	66 kg (SS134)
2583 lbf.ft	5166 lbf.ft	30996 lbf.ft			

TOP VIEW
俯视图

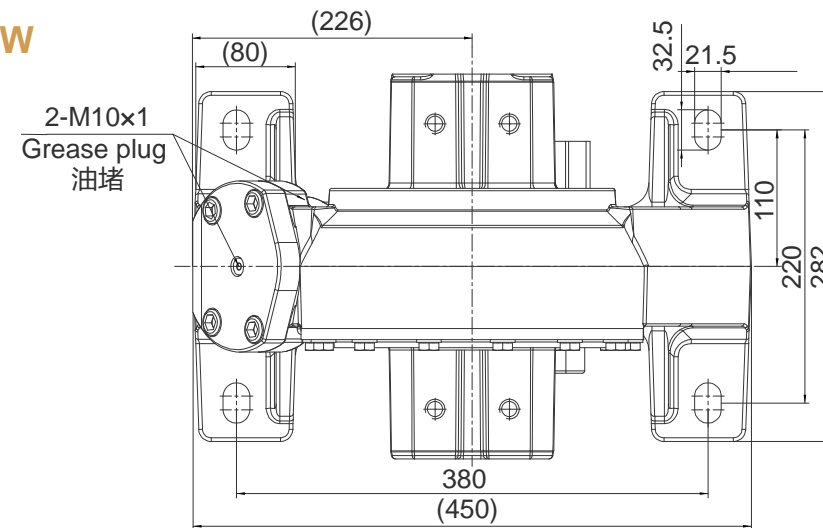

FRONT VIEW
正视图

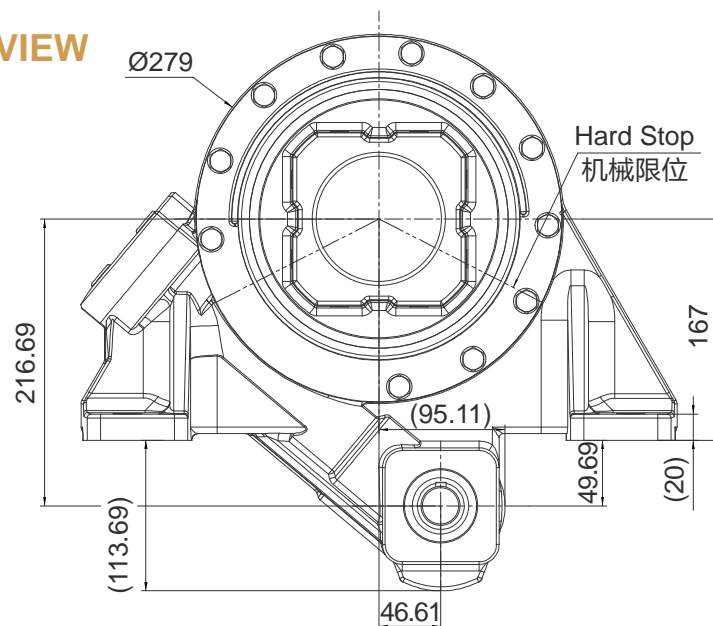

SIDE VIEW
侧视图

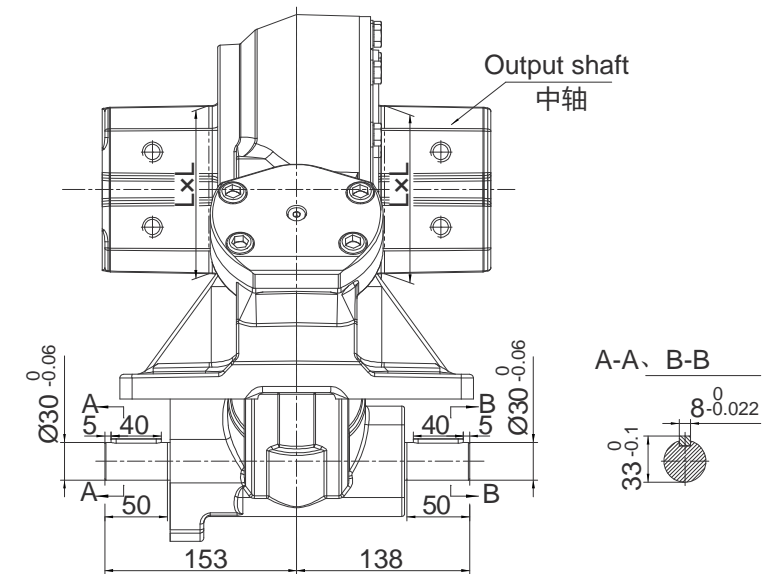

SPECIAL DESIGN BASE ON CUSTOMER'S REQUIREMENT
可根据顾客的要求进行非标设计

NOTICE 注意

- This drawing is just for your refenece.以上图纸仅供参考。
- This drawing is subject to change due to new design without prior notice.本公司保留改进产品的权利而不再另行通知。

SLEWING DRIVE 回转式减速器

VE8DA



UNITS: mm
单位: mm
1inch=25.4mm

Weight: 41kg

Slewing Drive Performance Parameters

VE8DA性能参数表

Rated Output Torque	Output Torque (Max.)	Holding Torque	Gear Ratio	Tracking Precision	Weight
额定输出转矩	最大输出转矩	保持力矩	减速比	精度等级	重量
5500 N.m	11 kN.m	45 kN.m	50 : 1	≤0.3°	41 kg (SS140)
4059 lbf.ft	8118 lbf.ft	33210 lbf.ft			

FRONT VIEW
正视图

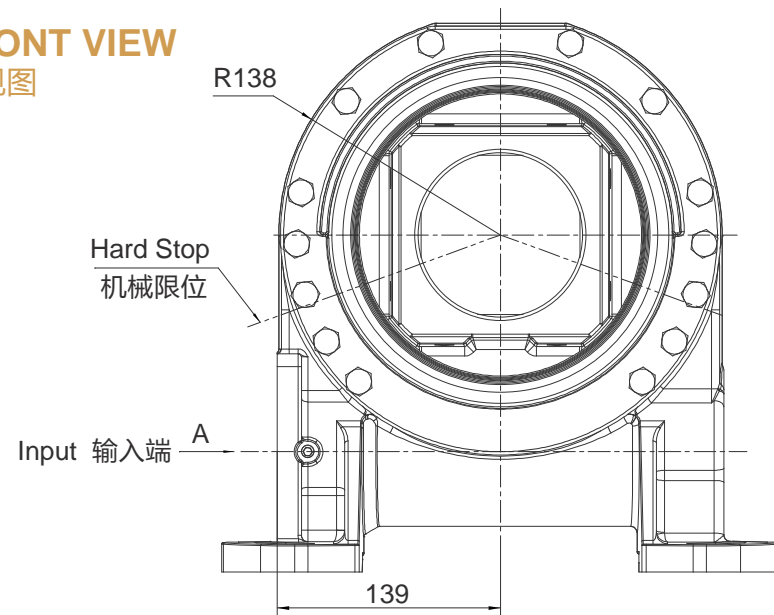

SPECIAL DESIGN BASE ON CUSTOMER'S REQUIREMENT
可根据顾客的要求进行非标设计

TOP VIEW
俯视图

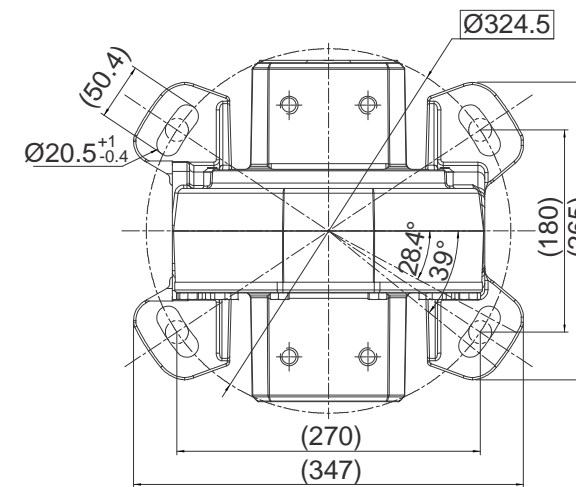

VIEW A
A向视图

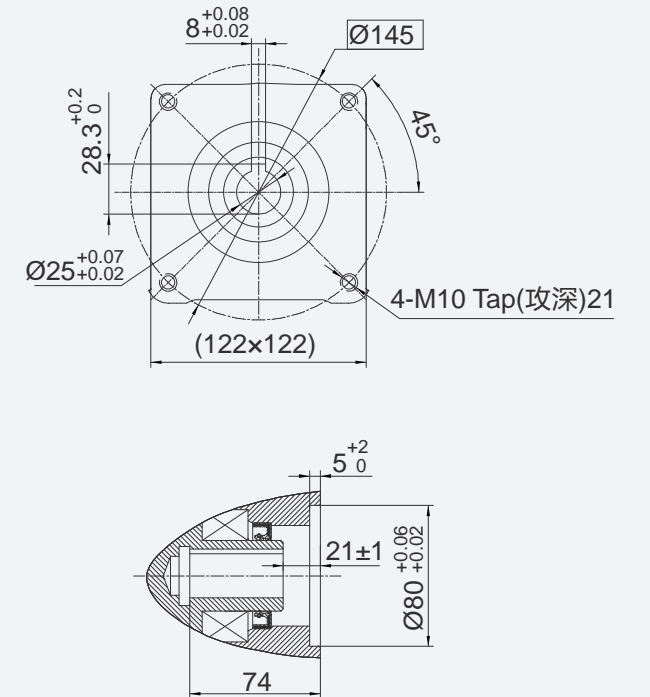

SIDE VIEW
侧视图

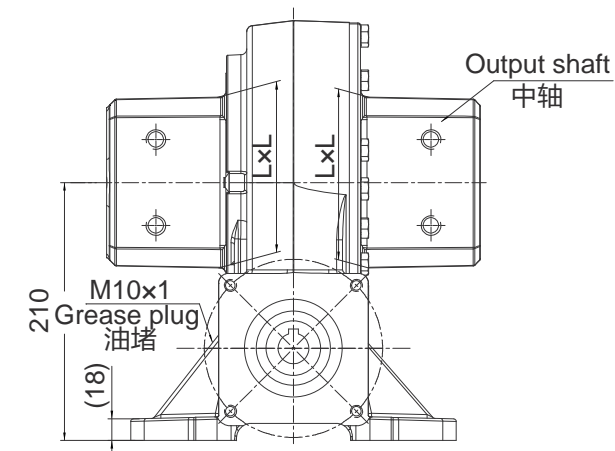

Type of output shaft Square 方形 Square 方形 Square 方形(max.)

Type of output shaft	Square 方形	Square 方形	Square 方形(max.)
中轴类型	SS110	SS113	SS140
Size 尺寸(LxL)	110x110	113x113	140x140

中轴类型、尺寸可根据客户要求, 进行非标设计(Customized)

NOTICE 注意

- This drawing is just for your reference. 以上图纸仅供参考。
- This drawing is subject to change due to new design without prior notice. 本公司保留改进产品的权利而不再另行通知。

SLEWING DRIVE (Active drive) 回转式减速器 (主动)

VE8DB



UNITS: mm
单位: mm
1inch=25.4mm

Weight: 72kg

Slewing Drive Performance Parameters
VE8DB (主动) 性能参数表

Rated Output Torque	Output Torque (Max.)	Holding Torque	Gear Ratio	Tracking Precision	Weight
额定输出转矩	最大输出转矩	保持力矩	减速比	精度等级	重量
3800 N.m	5700 N.m	45kN.m	60 : 1	≤0.3°	≈72 kg (SS142)
2804 lbf.ft	4206 lbf.ft	33210 lbf.ft			

FRONT VIEW
正视图

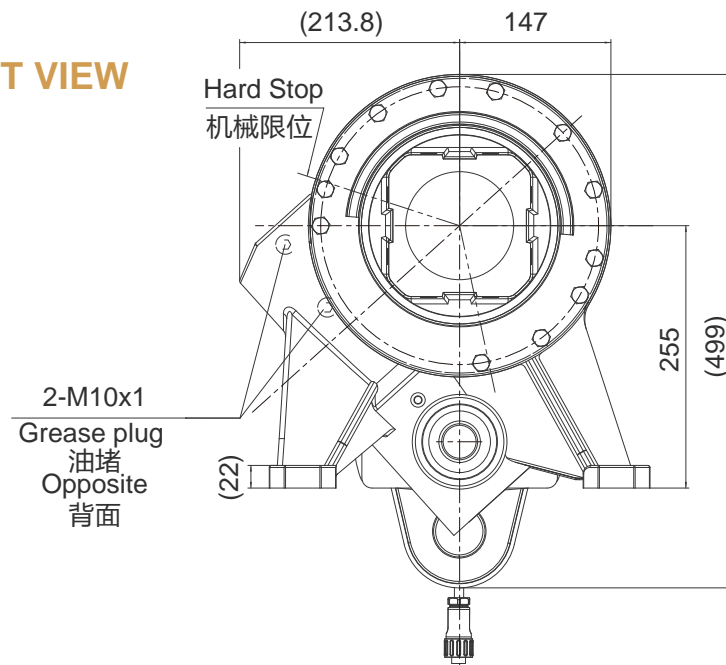

SPECIAL DESIGN BASE ON CUSTOMER'S REQUIREMENT
可根据顾客的要求进行非标设计

TOP VIEW
俯视图

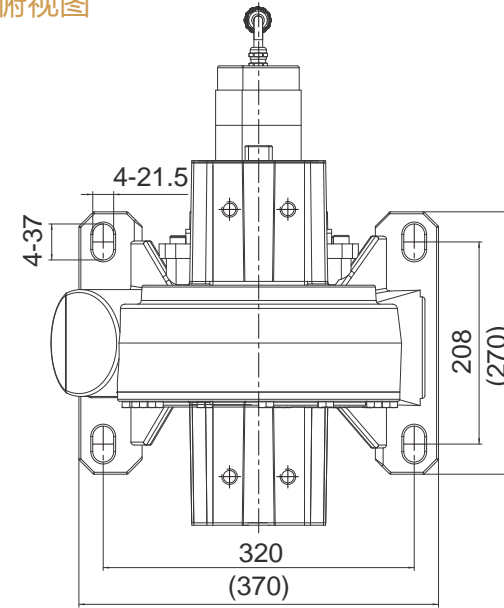

SIDE VIEW
侧视图

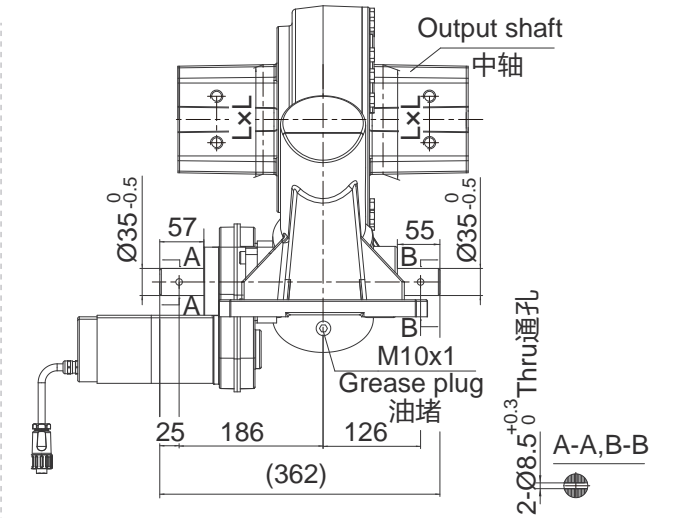

24VDC Planetary Reducer Motor Performance Data
24.10.550 直流有刷减速电机性能参数

Rated Voltage	Rated Speed	Rated Torque	Rated Current	IP Class
额定电压	额定转速	额定转矩	额定电流	防护等级
24 VDC	1 rpm	550N.m	≤7.1 A	IP65

One motor can drive three slewing drives. 一台电机可以驱动三台装置

Type of output shaft Square 方形(max.)

中轴类型 SS142

Size 尺寸(LxL) 142x142

中轴类型、尺寸可根据客户要求, 进行非标设计(Customized)

NOTICE 注意

- This drawing is just for your refenece. 以上图纸仅供参考。
- This drawing is subject to change due to new design without prior notice. 本公司保留改进产品的权利而不再另行通知。

SLEWING DRIVE (Passive drive) 回转式减速器 (从动)

VE8DB



UNITS: mm
单位: mm
1inch=25.4mm

Weight: 62kg

Slewing Drive Performance Parameters
VE8DB (从动) 性能参数表

Rated Output Torque	Output Torque (Max.)	Holding Torque	Gear Ratio	Tracking Precision	Weight
额定输出转矩	最大输出转矩	保持力矩	减速比	精度等级	重量
3800 N.m	5700 N.m	45kN.m	60 : 1	≤0.3°	≈62 kg (SS142)
2804 lbf.ft	4206 lbf.ft	33210 lbf.ft			

FRONT VIEW
正视图

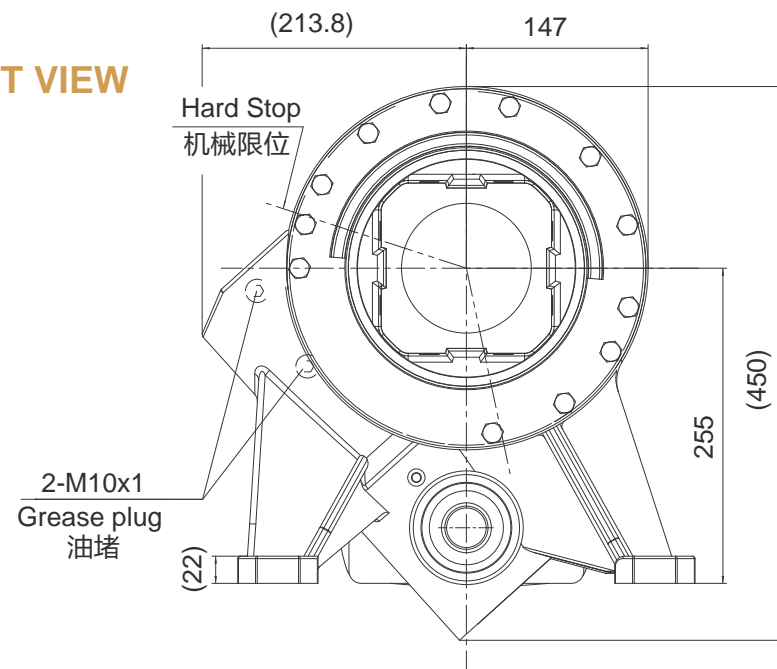

SPECIAL DESIGN BASE ON CUSTOMER'S REQUIREMENT
可根据顾客的要求进行非标设计

TOP VIEW
俯视图

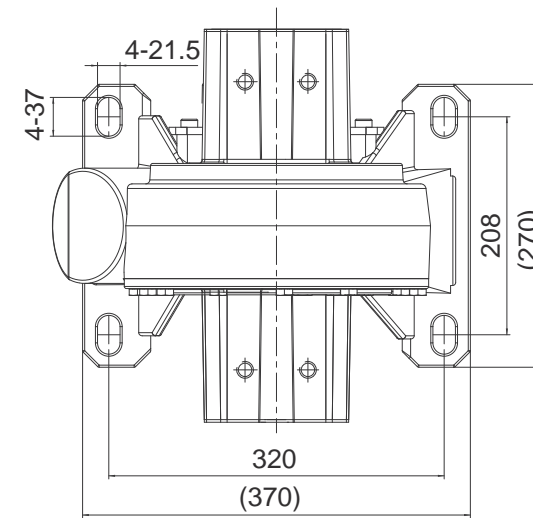

SIDE VIEW
侧视图

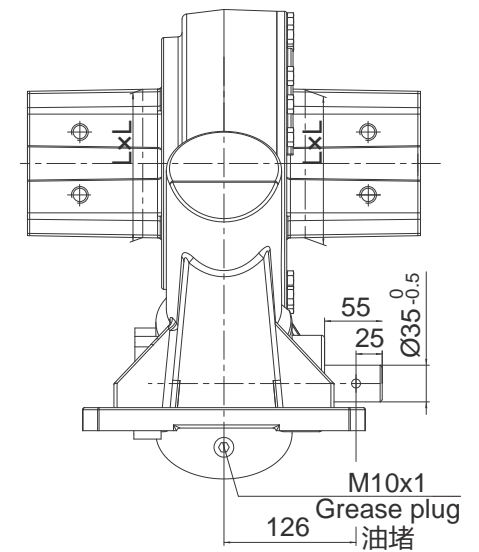

Type of output shaft	Square 方形(max.)
中轴类型	SS142
Size 尺寸(LxL)	142x142

中轴类型、尺寸可根据客户要求, 进行非标设计(Customized)

NOTICE 注意

- This drawing is just for your refenece. 以上图纸仅供参考。
- This drawing is susbject to change due to new design without prior notice. 本公司保留改进产品的权利而不再另行通知。

SLEWING DRIVE (Active drive) 回转式减速器 (主动)

VE8DH

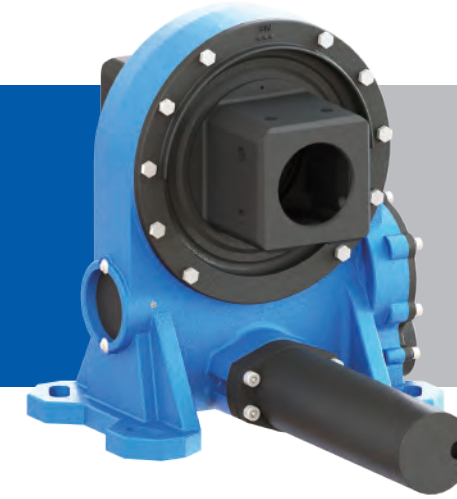

UNITS: mm
单位: mm
1inch=25.4mm

Weight: 90kg

Slewing Drive Performance Parameters
VE8DH (主动) 性能参数表

Rated Output Torque	Output Torque (Max.)	Holding Torque	Gear Ratio	Tracking Precision	Weight
额定输出转矩	最大输出转矩	保持力矩	减速比	精度等级	重量
5000 N.m	11500 N.m	55kN.m	134 : 1	≤0.3°	≈90 kg (SS140)
2804 lbf.ft	8487 lbf.ft	40590 lbf.ft			

FRONT VIEW
正视图

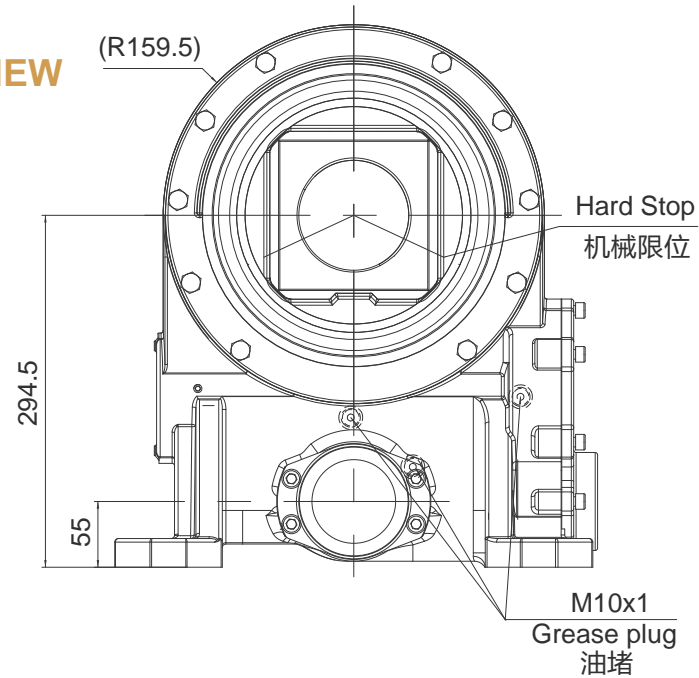

SPECIAL DESIGN BASE ON CUSTOMER'S REQUIREMENT
可根据顾客的要求进行非标设计

TOP VIEW
俯视图

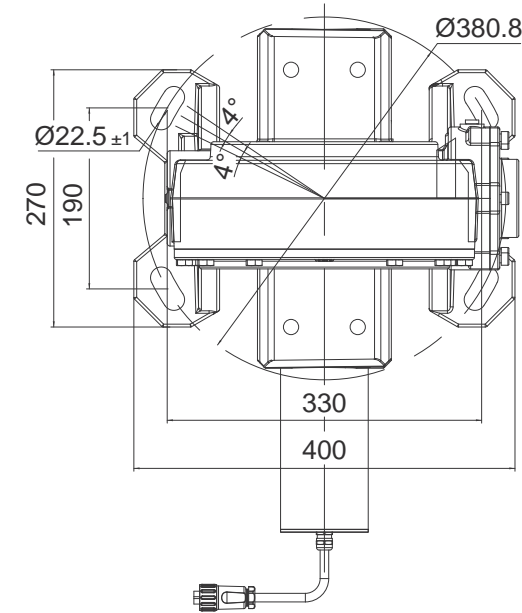

SIDE VIEW
侧视图

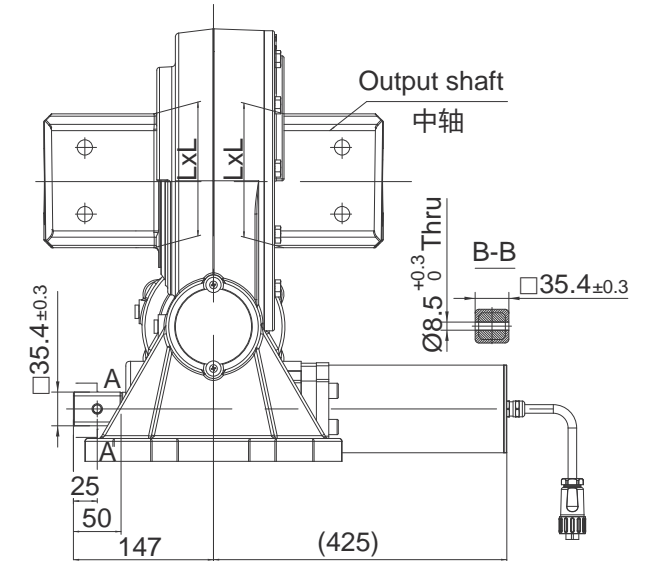

24VDC Planetary Reducer Motor Performance Data
24.20.420 直流有刷减速电机性能参数

Rated Voltage	Rated Speed	Rated Torque	Rated Current	IP Class
额定电压	额定转速	额定转矩	额定电流	防护等级
24 VDC	2 rpm	420N.m	≤8 A	IP65

One motor can drive two slewing drives. 一台电机可以驱动两台装置

Type of output shaft	Square 方形(max.)
中轴类型	SS140.5
Size 尺寸(LxL)	140.5x140.5

中轴类型、尺寸可根据客户要求, 进行非标设计(Customized)

NOTICE 注意

- This drawing is just for your reference. 以上图纸仅供参考。
- This drawing is subject to change due to new design without prior notice. 本公司保留改进产品的权利而不再另行通知。

SLEWING DRIVE (Passive drive) 回转式减速器 (从动)

VE8DH

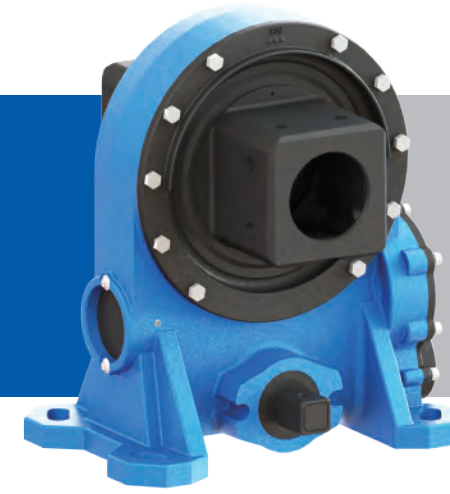

UNITS: mm
单位: mm
1inch=25.4mm

Weight: 90kg

Slewing Drive Performance Parameters
VE8DH (从动) 性能参数表

Rated Output Torque	Output Torque (Max.)	Holding Torque	Gear Ratio	Tracking Precision	Weight
额定输出转矩	最大输出转矩	保持力矩	减速比	精度等级	重量
5000 N.m	11500 N.m	55kN.m	134 : 1	≤0.3°	≈90 kg (SS140)
2804 lbf.ft	8487 lbf.ft	40590 lbf.ft			

FRONT VIEW
正视图

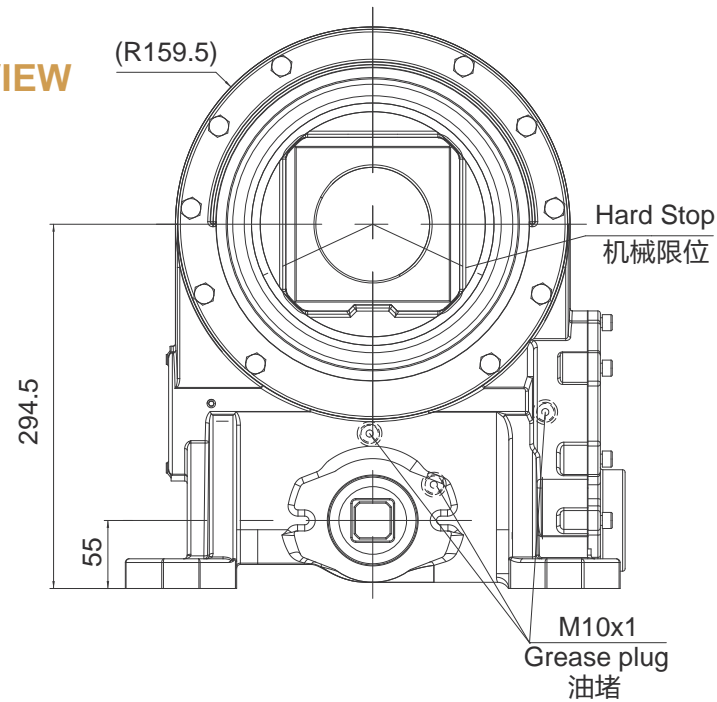

SPECIAL DESIGN BASE ON CUSTOMER'S REQUIREMENT
可根据顾客的要求进行非标设计

TOP VIEW
俯视图

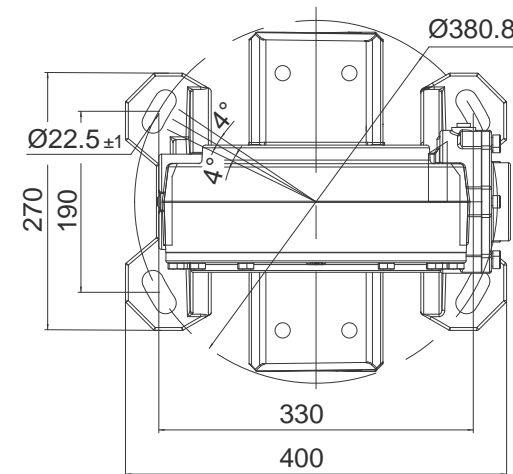

SIDE VIEW
侧视图

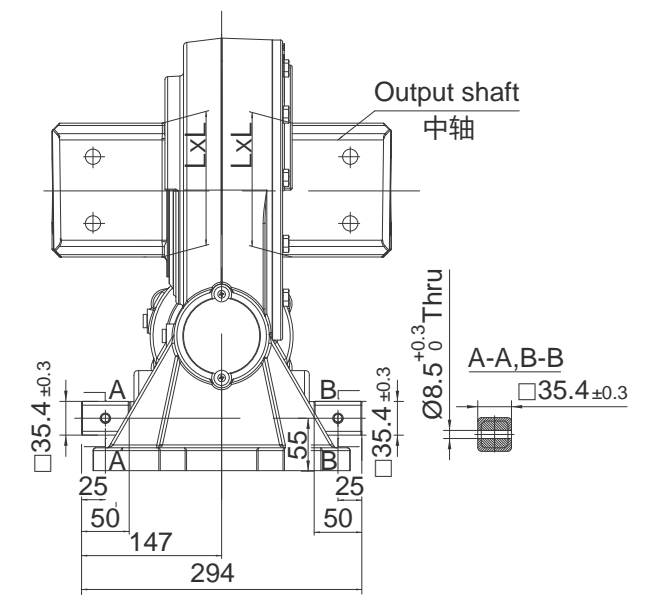

Type of output shaft	Square 方形(max.)
中轴类型	SS140.5
Size 尺寸(LxL)	140.5x140.5

中轴类型、尺寸可根据客户要求, 进行非标设计(Customized)

NOTICE 注意

- This drawing is just for your refenece. 以上图纸仅供参考。
- This drawing is susbject to change due to new design without prior notice. 本公司保留改进产品的权利而不再另行通知。

SLEWING DRIVE 回转式减速器

VE8DN



UNITS: mm
单位: mm
1inch=25.4mm

Weight: 50kg

Slewing Drive Performance Parameters
VE8DN 性能参数表

Rated Output Torque	Output Torque (Max.)	Holding Torque	Gear Ratio	Tracking Precision	Weight
额定输出转矩	最大输出转矩	保持力矩	减速比	精度等级	重量
4500 N.m	6500 N.m	45kN.m	516.7 : 1	≤0.3°	≈50kg (SS142)
3321 lbf.ft	4797 lbf.ft	33210 lbf.ft			

TOP VIEW
俯视图

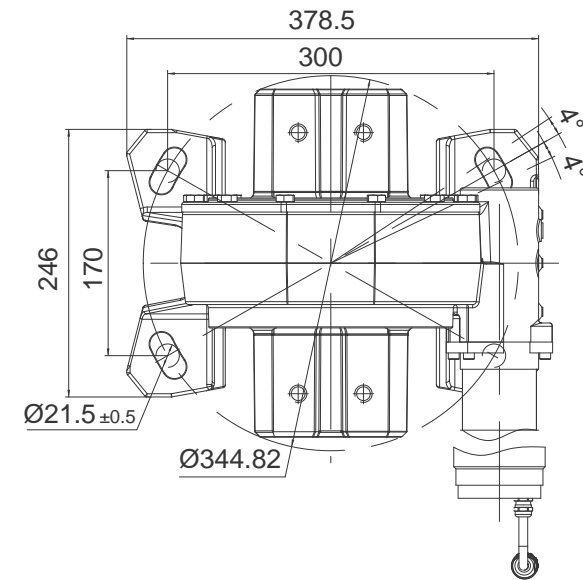

SIDE VIEW
侧视图

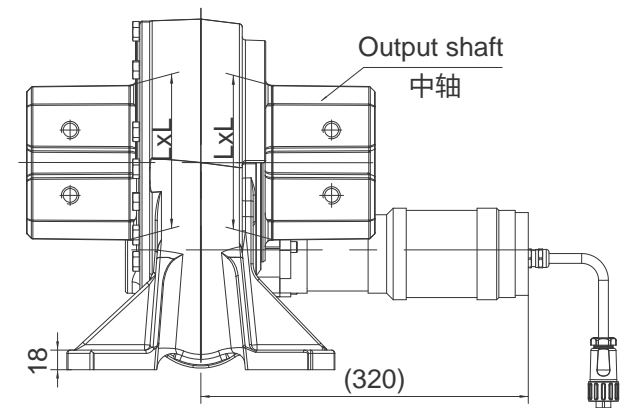

FRONT VIEW
正视图

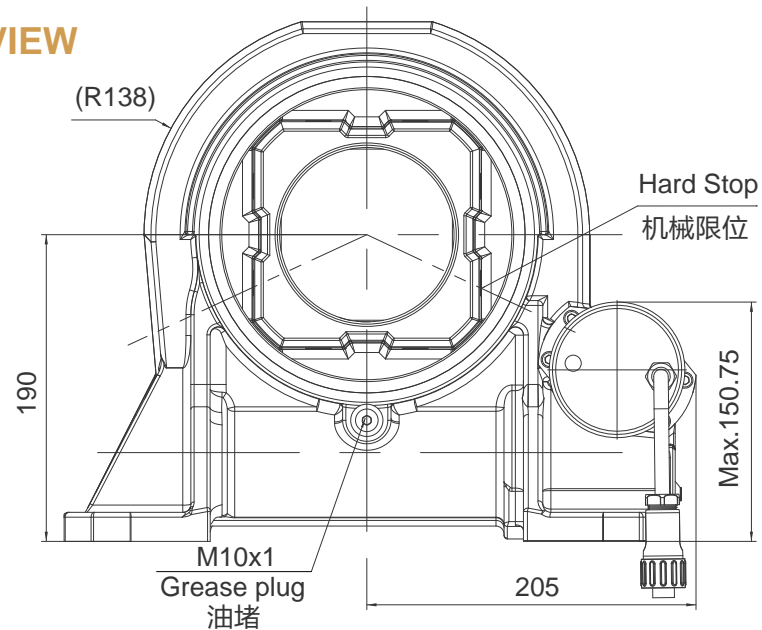

SPECIAL DESIGN BASE ON CUSTOMER'S REQUIREMENT
可根据顾客的要求进行非标设计

24VDC Planetary Reducer Motor Performance Data
24.60.40 直流有刷减速电机性能参数

Rated Voltage	Rated Speed	Rated Torque	Rated Current	IP Class
额定电压	额定转速	额定转矩	额定电流	防护等级
24 VDC	9.5 rpm	43N.m	≤3.6A	IP65

Type of output shaft Square 方形(max.)

中轴类型 SS142

Size 尺寸(LxL) 142x142

中轴类型、尺寸可根据客户要求, 进行非标设计(Customized)

NOTICE 注意

- This drawing is just for your refenece. 以上图纸仅供参考。
- This drawing is subject to change due to new design without prior notice. 本公司保留改进产品的权利而不再另行通知。

SLEWING DRIVE (Active drive) 回转式减速器 (主动)

VE8DQ



UNITS: mm
单位: mm
1inch=25.4mm

Weight: 78kg

Slewing Drive Performance Parameters
VE8DQ (主动) 性能参数表

Rated Output Torque	Output Torque (Max.)	Holding Torque	Gear Ratio	Tracking Precision	Weight
额定输出转矩	最大输出转矩	保持力矩	减速比	精度等级	重量
2500N.m	3750N.m	68.5 kN.m	750: 1	≤0.3°	≈78 kg (OC225.8x157.5)
1845lbf.ft	2767.5lbf.ft	50553 lbf.ft			

FRONT VIEW
正视图

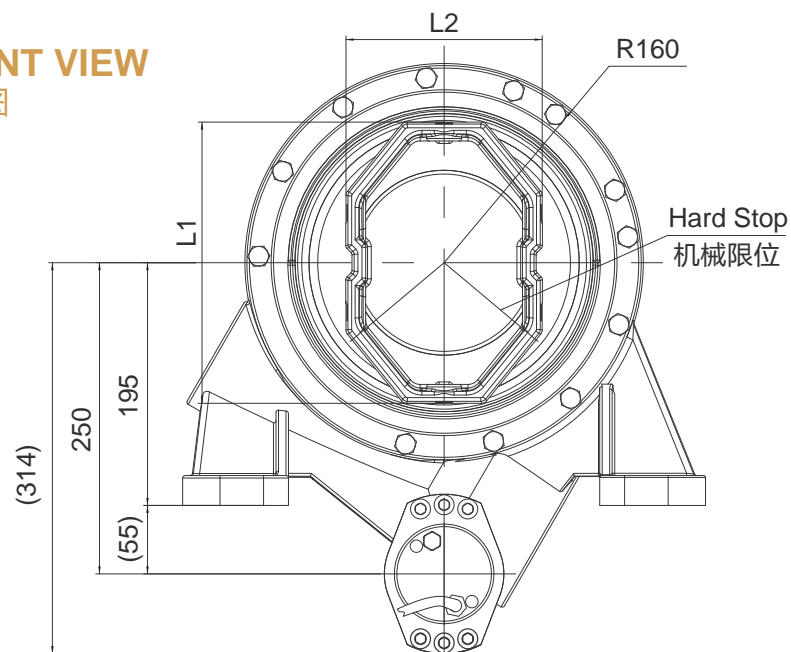

SPECIAL DESIGN BASE ON CUSTOMER'S REQUIREMENT
可根据顾客的要求进行非标设计

TOP VIEW
俯视图

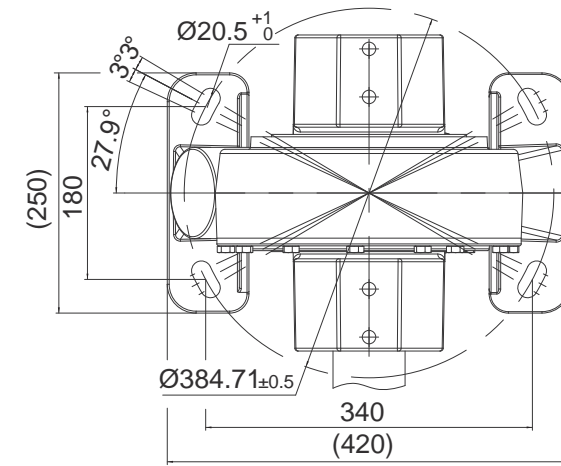

SIDE VIEW
侧视图

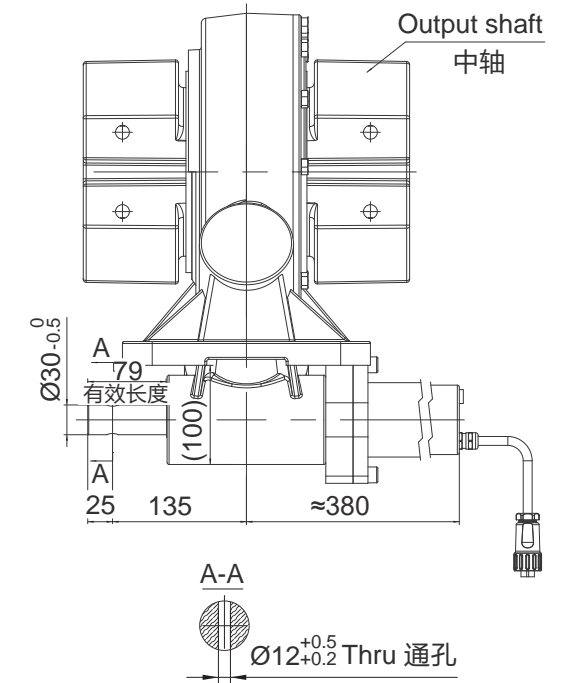

Type of output shaft	Octagon 八边形(max.)
中轴类型	OC225.8x157.5
Size 尺寸(L1xL2)	225.8x157.5

中轴类型、尺寸可根据客户要求, 进行非标设计(Customized)

NOTICE 注意

- This drawing is just for your refenece. 以上图纸仅供参考。
- This drawing is susbject to change due to new design without prior notice. 本公司保留改进产品的权利而不再另行通知。

SLEWING DRIVE (Passive drive) 回转式减速器 (从动)

VE8DQ



UNITS: mm
单位: mm
1inch=25.4mm

Weight: 70kg

Slewing Drive Performance Parameters
VE8DQ (从动) 性能参数表

Rated Output Torque	Output Torque (Max.)	Holding Torque	Gear Ratio	Tracking Precision	Weight
额定输出转矩	最大输出转矩	保持力矩	减速比	精度等级	重量
2500N.m	3750N.m	68.5 kN.m	750 : 1	≤0.3°	≈70 kg (OC225.8×157.5)
1845lbf.ft	2767.5lbf.ft	50553 lbf.ft			

FRONT VIEW
正视图

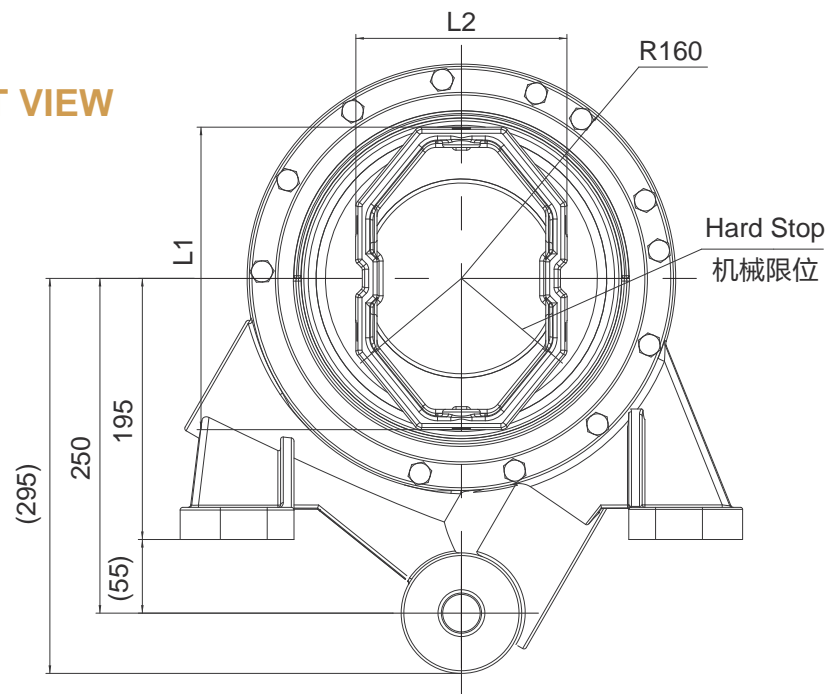

SPECIAL DESIGN BASE ON CUSTOMER'S REQUIREMENT
可根据顾客的要求进行非标设计

TOP VIEW
俯视图

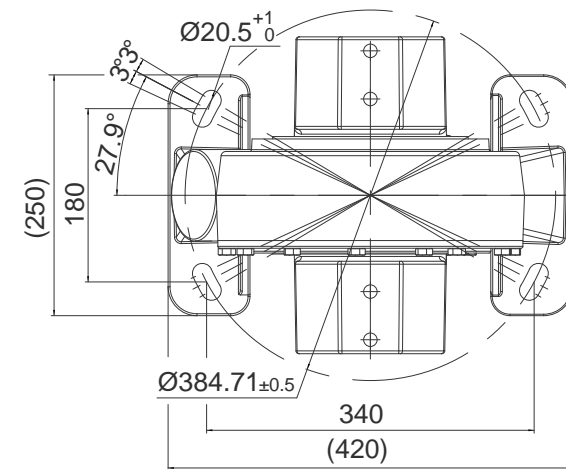

SIDE VIEW
侧视图

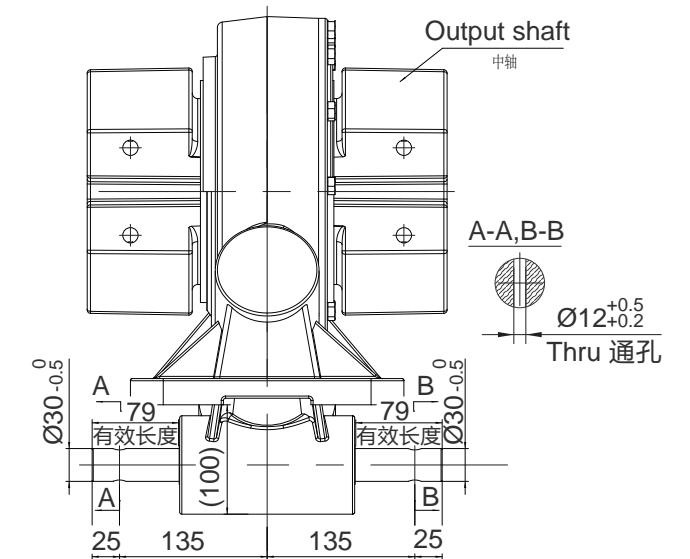

24VDC Planetary Reducer Motor Performance Data
32.80.150 直流有刷减速电机性能参数

Rated Voltage	Rated Speed	Rated Torque	Rated Current	IP Class
额定电压	额定转速	额定转矩	额定电流	防护等级
32 VDC	8 rpm	150N.m	≤8 A	IP65

One motor can drive three slewing drives. 一台电机可以驱动四台装置

NOTICE 注意

- This drawing is just for your refenece. 以上图纸仅供参考。
- This drawing is susbject to change due to new design without prior notice. 本公司保留改进产品的权利而不再另行通知。

SLEWING DRIVE 回转式减速器

VE8GA



UNITS: mm
单位: mm
1inch=25.4mm

Weight: 56kg

Slewing Drive Performance Parameters

VE8GA 性能参数表

Rated Output Torque	Output Torque (Max.)	Holding Torque	Gear Ratio	Tracking Precision	Weight
额定输出转矩	最大输出转矩	保持力矩	减速比	精度等级	重量
5500 N.m	11 kN.m	45 kN.m	50 : 1	≤0.3°	56 kg (SS140)
4059 lbf.ft	8118 lbf.ft	33210 lbf.ft			

FRONT VIEW
正视图

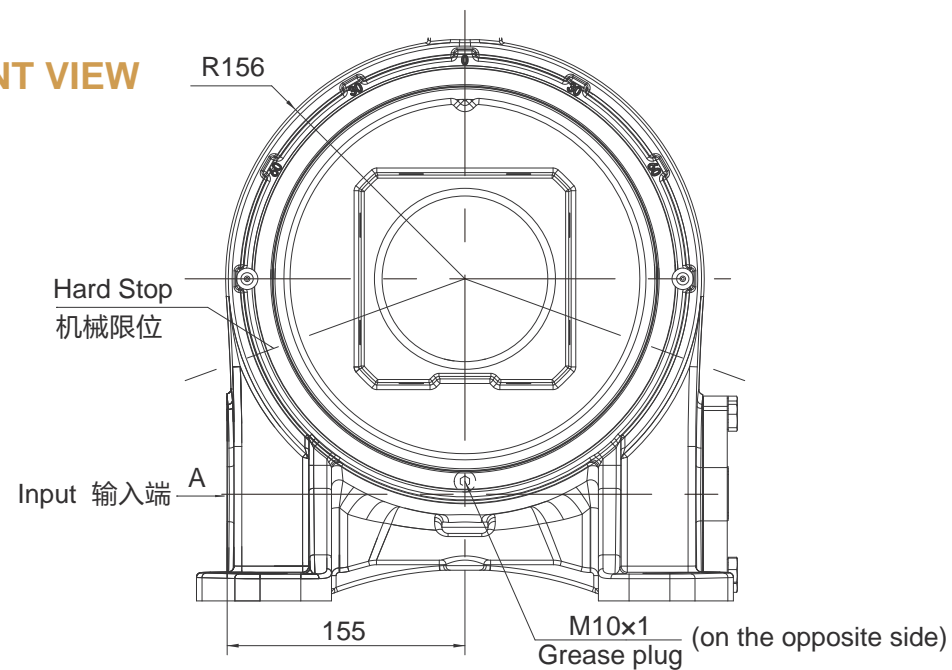

SPECIAL DESIGN BASE ON CUSTOMER'S REQUIREMENT
可根据顾客的要求进行非标设计

TOP VIEW
俯视图

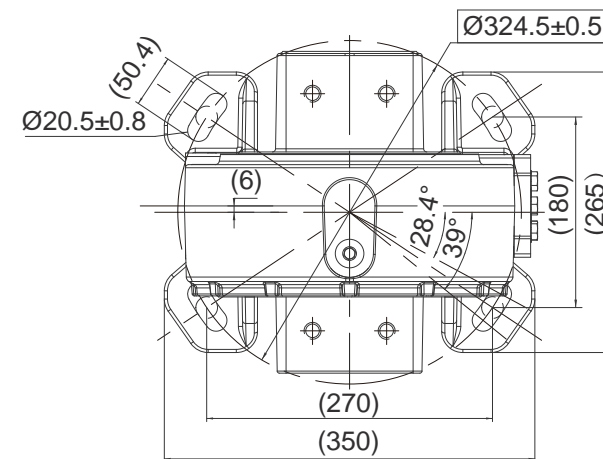

VIEW A
A向视图

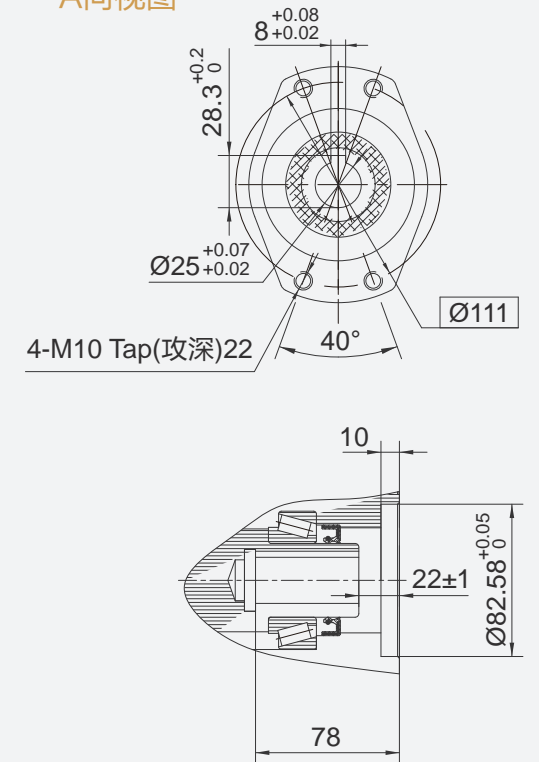

SIDE VIEW
侧视图

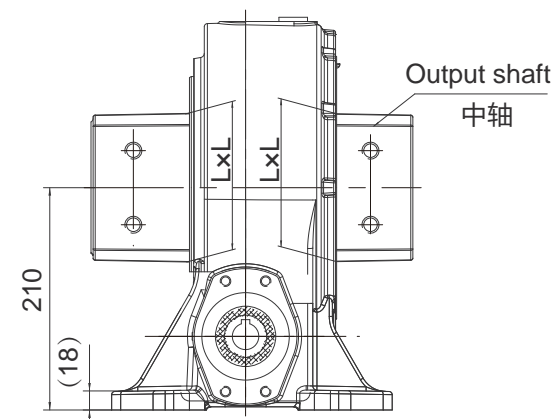

Type of output shaft	Square 方形	Square 方形(max.)
中轴类型	SS138	SS140
Size 尺寸(LxL)	138x138	140x140

中轴类型、尺寸可根据客户要求, 进行非标设计(Customized)

NOTICE 注意

- This drawing is just for your reference. 以上图纸仅供参考。
- This drawing is subject to change due to new design without prior notice. 本公司保留改进产品的权利而不再另行通知。

SLEWING DRIVE 回转式减速器

VE9D

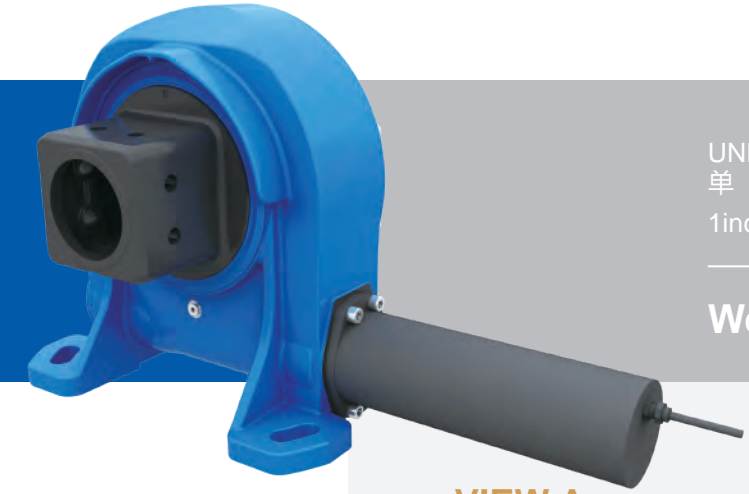

UNITS: mm
单位: mm
1inch=25.4mm

Weight: 71kg

Slewing Drive Performance Parameters

VE9D性能参数表

Rated Output Torque	Output Torque (Max.)	Holding Torque	Gear Ratio	Tracking Precision	Weight
额定输出转矩	最大输出转矩	保持力矩	减速比	精度等级	重量
6500 N.m	14000 N.m	65 kN.m	61 : 1	≤0.3°	71 kg (SS139.5)
4797 lbf.ft	10332 lbf.ft	47970 lbf.ft			

FRONT VIEW
正视图

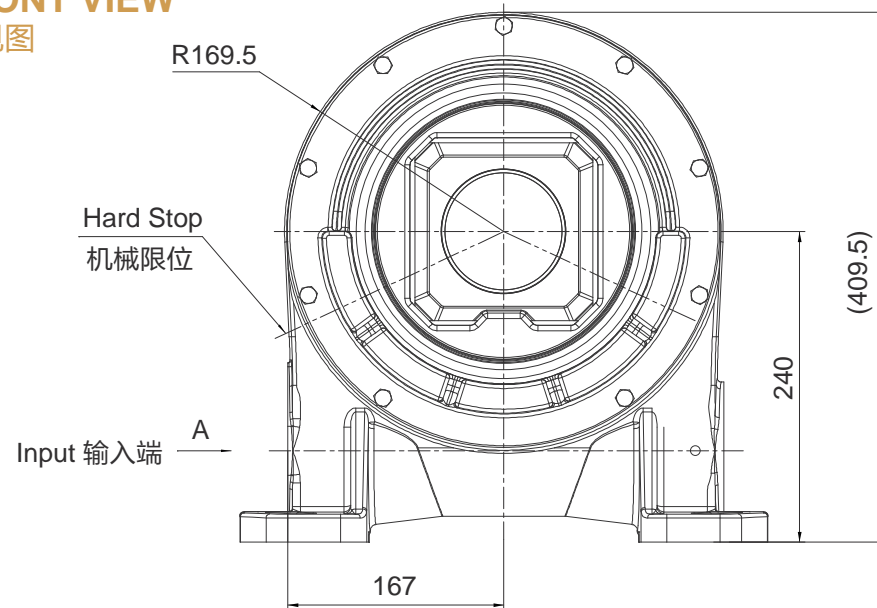

SPECIAL DESIGN BASE ON CUSTOMER'S REQUIREMENT
可根据顾客的要求进行非标设计

TOP VIEW
俯视图

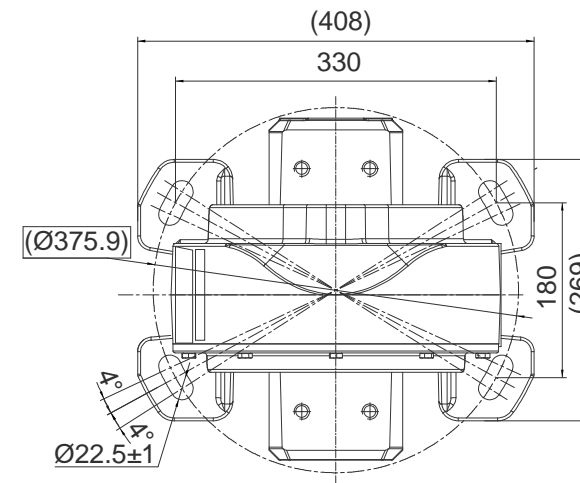

VIEW A
A向视图

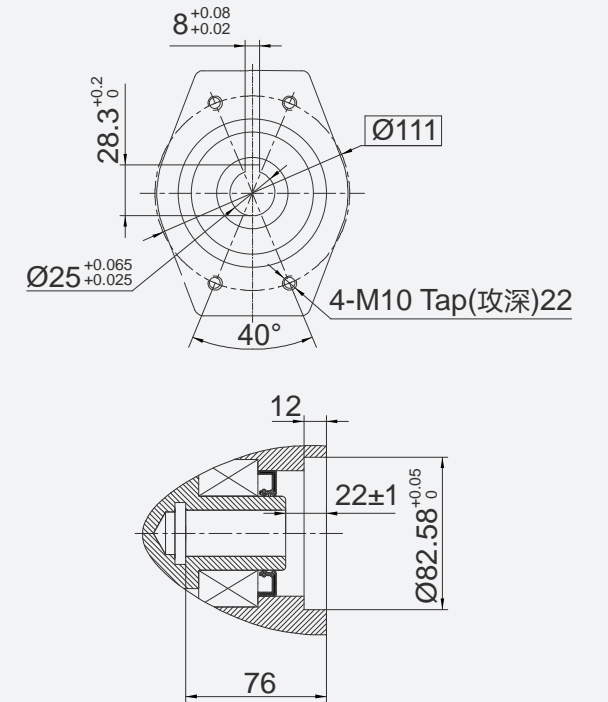

SIDE VIEW
侧视图

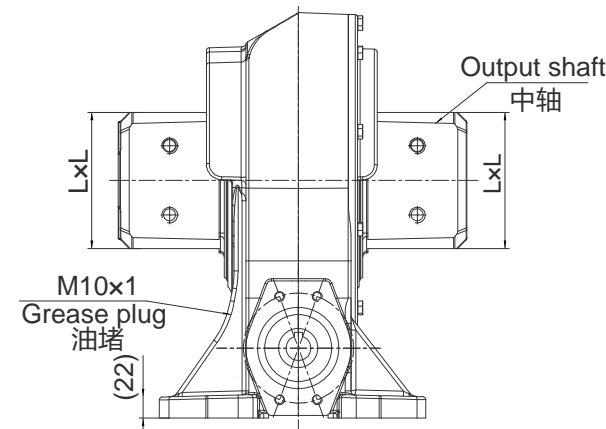

Type of output shaft	Square 方形	Square 方形	Square 方形	Square 方形	Square 方形(max.)
----------------------	-----------	-----------	-----------	-----------	-----------------

中轴类型	SS112	SS126	SS138	SS140	SS154
------	-------	-------	-------	-------	-------

Size 尺寸(LxL)	112x112	126x126	138x138	140x140	154x154
--------------	---------	---------	---------	---------	---------

中轴类型、尺寸可根据客户要求, 进行非标设计(Customized)

NOTICE 注意

- This drawing is just for your reference. 以上图纸仅供参考。
- This drawing is subject to change due to new design without prior notice. 本公司保留改进产品的权利而不再另行通知。

SLEWING DRIVE 回转式减速器

VE10D

UNITS: mm
单位: mm
1inch=25.4mm

Weight: 88kg

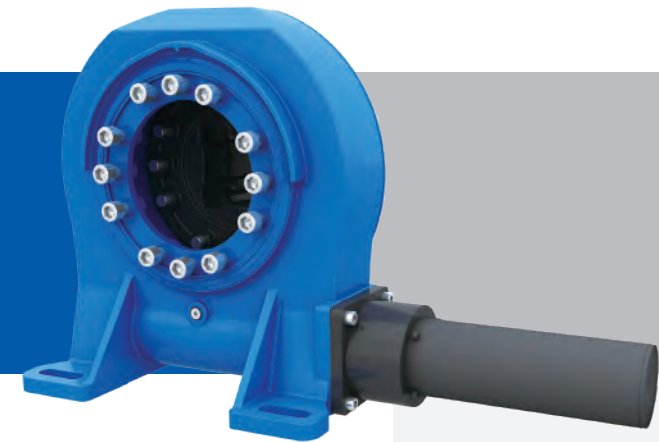

Slewing Drive Performance Parameters

VE10D性能参数表

Rated Output Torque	Output Torque (Max.)	Holding Torque	Gear Ratio	Tracking Precision	Weight
额定输出转矩	最大输出转矩	保持力矩	减速比	精度等级	重量
8500 N.m	18 kN.m	75 kN.m	80 : 1	≤0.3°	88 kg (SS137)
6273 lbf.ft	13284 lbf.ft	55350 lbf.ft			

TOP VIEW
俯视图

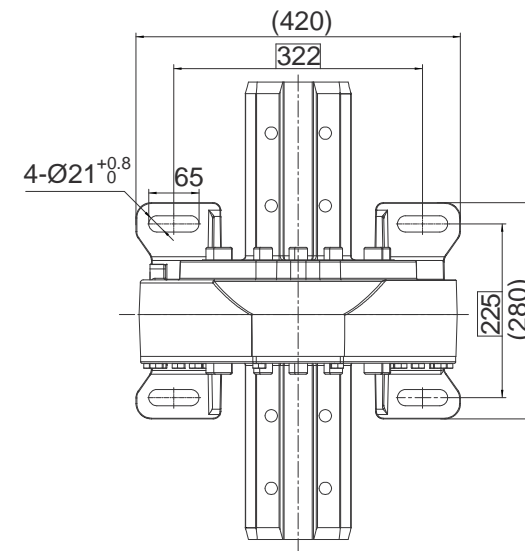

VIEW A
A向视图

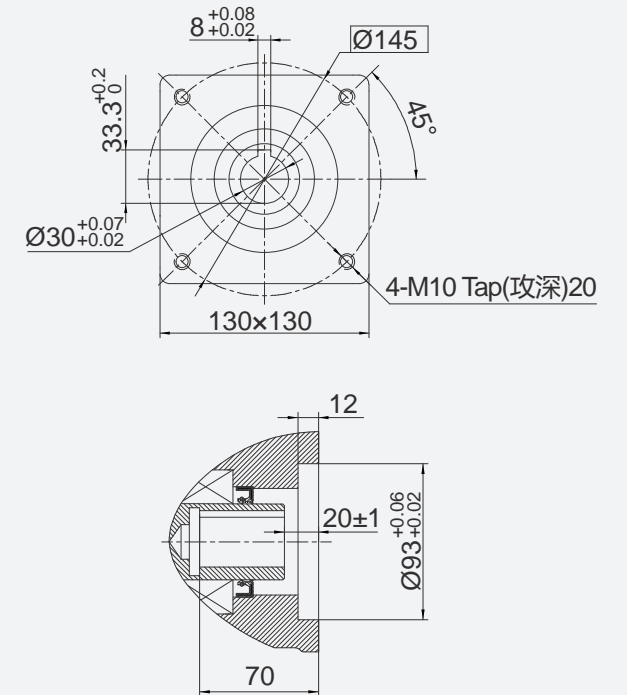

FRONT VIEW
正视图

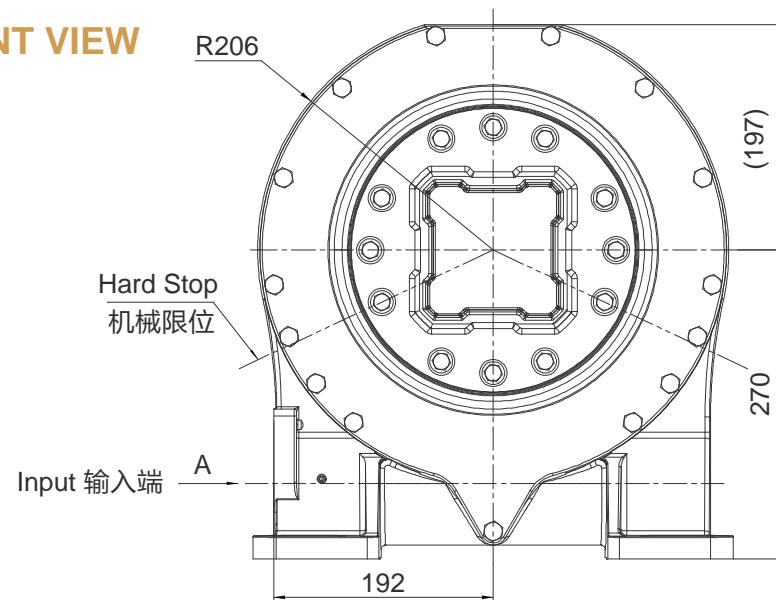

SPECIAL DESIGN BASE ON CUSTOMER'S REQUIREMENT
可根据顾客的要求进行非标设计

SIDE VIEW
侧视图

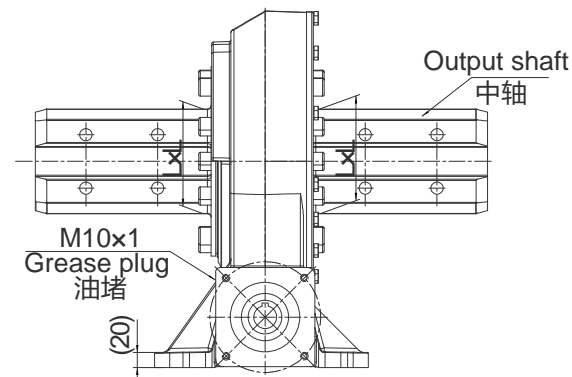

Type of output shaft	Square 方形
中轴类型	SS137
Size尺寸(LxL)	137x137

中轴类型、尺寸可根据客户要求, 进行非标设计(Customized)

NOTICE 注意

- This drawing is just for your reference. 以上图纸仅供参考。
- This drawing is subject to change due to new design without prior notice. 本公司保留改进产品的权利而不再另行通知。

SLEWING DRIVE 回转式减速器

WDP21



UNITS: mm
单位: mm
1inch=25.4mm

Weight: 545kg

Slewing Drive Performance Parameters

WDP21性能参数表

Model	Output Torque	Tilting Moment Torque	Holding Torque	Static Axial Rating	Static Radial Rating	Gear Ratio	Tracking Precision	Weight
类型	输出转矩	倾覆力矩	保持力矩	轴向静载荷	径向静载荷	减速比	精度等级	重量
Azimuth 方位	40 kN.m	200 kN.m	105 kN.m	385 kN	335 kN	105 : 1	≤ 0.2°	545 kg
	29520 lbf.ft	148×10 ³ lbf.ft	77×10 ³ lbf.ft	87×10 ³ lbf	75×10 ³ lbf			
Elevation 俯仰	43 kN.m	110 kN.m	100 kN.m	100 kN	200 kN	105 : 1	≤ 0.2°	
	31734 lbf.ft	81×10 ³ lbf.ft	50×10 ³ lbf.ft	22×10 ³ lbf	45×10 ³ lbf			

FRONT VIEW 正视图

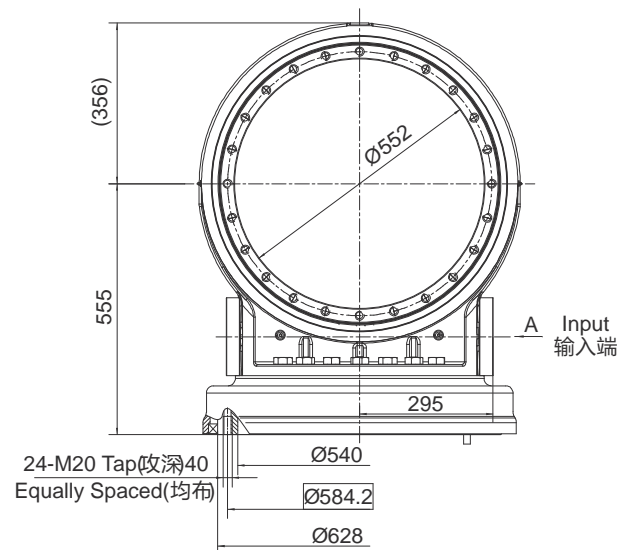

SIDE VIEW 侧视图

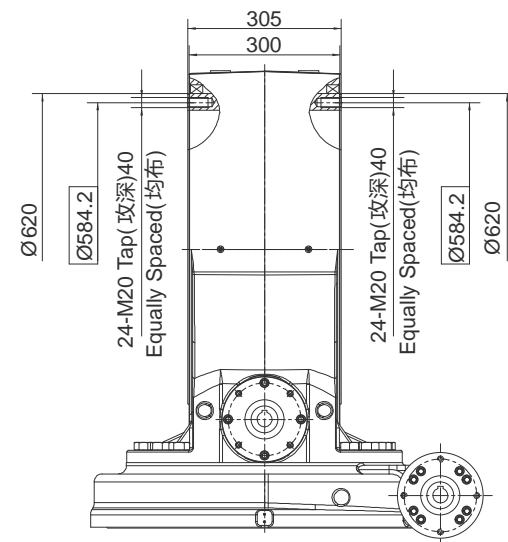

SPECIAL DESIGN BASE ON CUSTOMER'S REQUIREMENT
可根据顾客的要求进行非标设计

TOP VIEW 俯视图

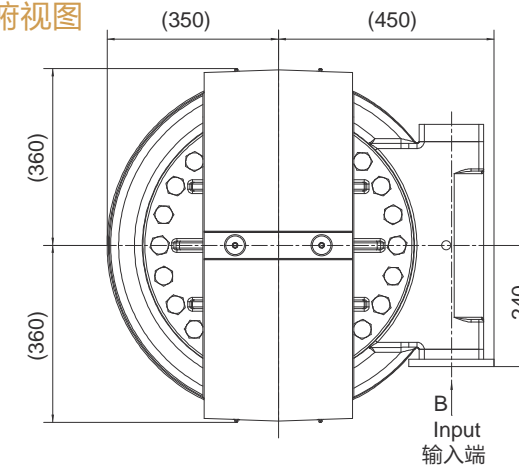

MOMENT LOAD CHART 承载力矩图

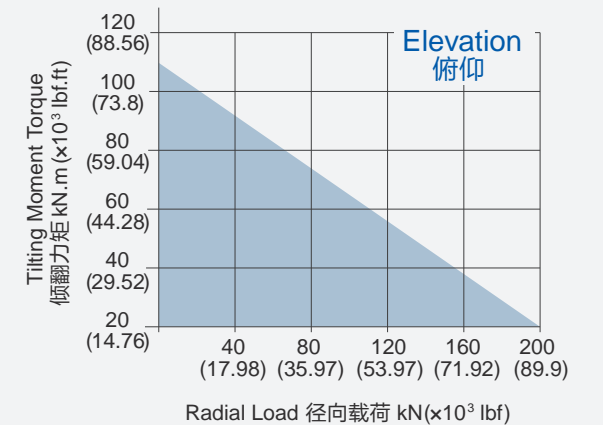
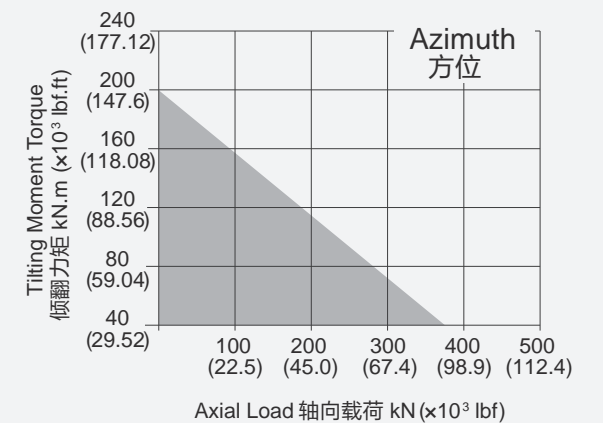

PLEASE BE SURE TO REMAIN UNDER THIS CURVE
选型时请确保实际载荷在曲线范围内

NOTICE 注意

- This drawing is just for your reference. 以上图纸仅供参考。
- This drawing is subject to change due to new design without prior notice. 本公司保留改进产品的权利而不再另行通知。

VIEW A A向视图

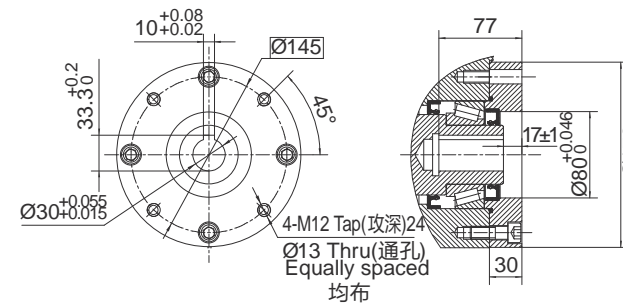

VIEW B B向视图

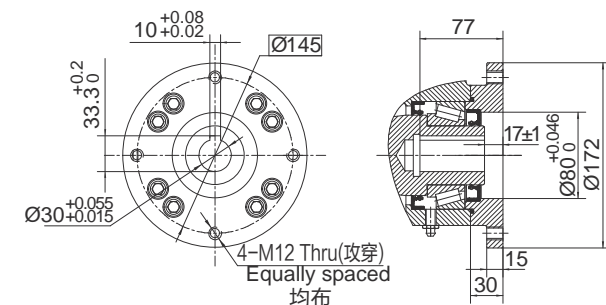

SLEWING DRIVE 回转式减速器

SDE7A.5 PDE7A.5

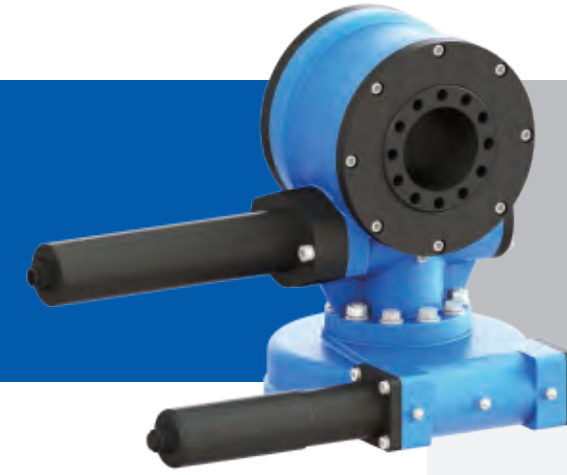

UNITS: mm
单位: mm
1inch=25.4mm

Weight: 23kg/33kg

Slewing Drive Performance Parameters
SDE7A.5/PDE7A.5 性能参数表

Model	Output Torque	Tilting Moment Torque	Holding Torque	Static Axial Rating	Static Radial Rating	Gear Ratio	Tracking Precision		Weight
							SDE7A.5	PDE7A.5	
Azimuth 方位	1500 N.m	13500 N.m	10400 N.m	133 kN	53 kN	73 : 1	≤ 0.2°	≤ 0.1°	25 kg
	1107 lbf.ft	9957 lbf.ft	7671 lbf.ft	29900 lbf	11915 lbf		≤ 0.2°	≤ 0.1°	
Elevation 俯仰	2000 N.m	10 kN.m	9000 N.m	60 kN	120 kN	28 : 1	≤ 0.2°	≤ 0.1°	33 kg
	1476 lbf.ft	7380 lbf.ft	6642 lbf.ft	13488 lbf	26976 lbf		≤ 0.2°	≤ 0.1°	

SIDE VIEW
侧视图

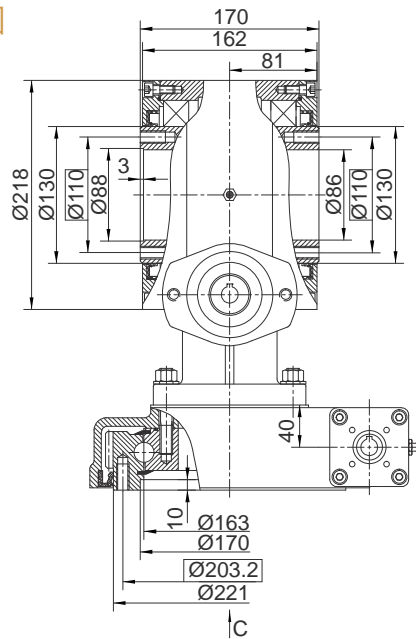

FRONT VIEW
正视图

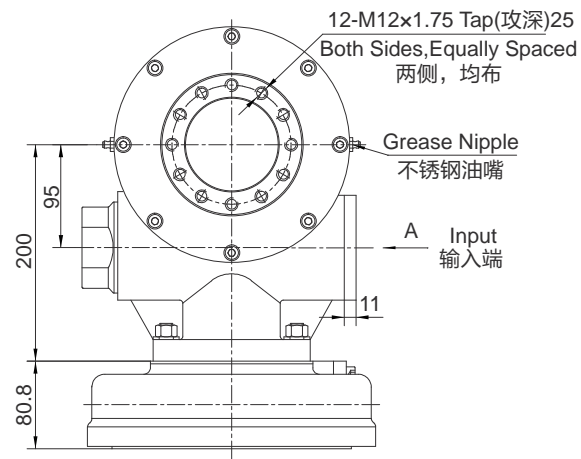

SPECIAL DESIGN BASE ON CUSTOMER'S REQUIREMENT
可根据顾客的要求进行非标设计

View C
C向

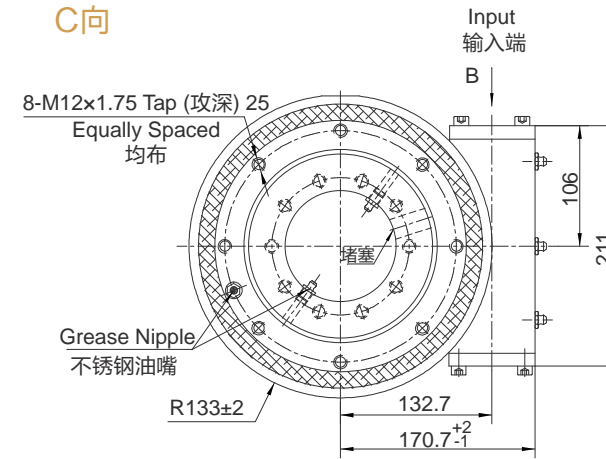

VIEW A
A向视图

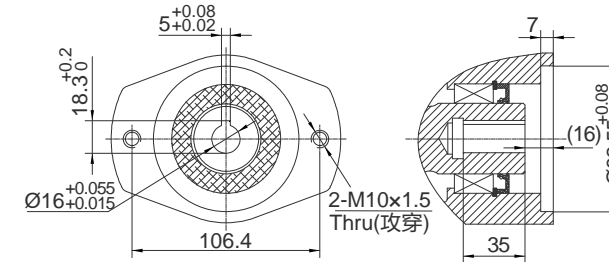

VIEW B
B向视图

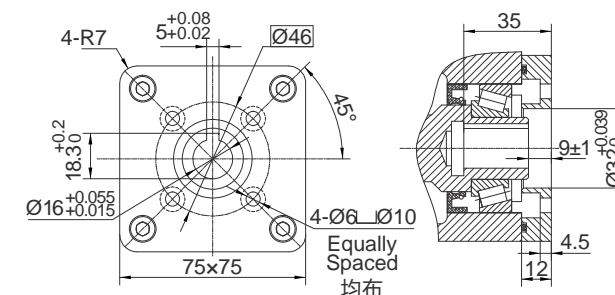

MOMENT LOAD CHART
承载力矩图

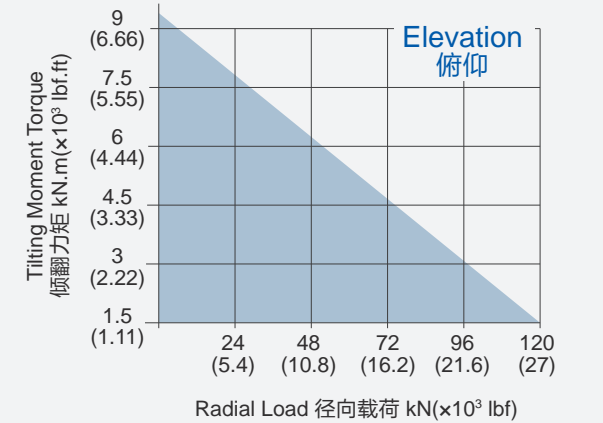
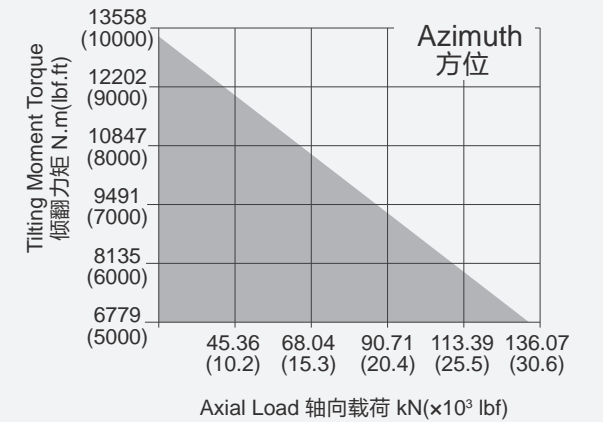

PLEASE BE SURE TO REMAIN UNDER THIS CURVE
选型时请确保实际载荷在曲线范围内

NOTICE 注意

- This drawing is just for your reference. 以上图纸仅供参考。
- This drawing is subject to change due to new design without prior notice. 本公司保留改进产品的权利而不再另行通知。

SLEWING DRIVE 回转式减速器

SDE17C



UNITS: mm
单位: mm
1inch=25.4mm

Weight: 390kg

Slewing Drive Performance Parameters

SDE17C性能参数表

Model	Output Torque	Tilting Moment Torque	Holding Torque	Static Axial Rating	Static Radial Rating	Gear Ratio	Tracking Precision	Weight
类型	输出转矩	倾覆力矩	保持力矩	轴向静载荷	径向静载荷	减速比	精度等级	重量
Azimuth 方位	20 kN.m	135.6 kN.m	72.3 kN.m	970 kN	390 kN	102 : 1	≤ 0.2°	390 kg
	14760 lbf.ft	100×10 ³ lbf.ft	53×10 ³ lbf.ft	218×10 ³ lbf	88×10 ³ lbf			
Elevation 俯仰	20 kN.m	70 kN.m	68 kN.m	80 kN	180 kN	102 : 1	≤ 0.2°	
	14760 lbf.ft	52×10 ³ lbf.ft	50×10 ³ lbf.ft	18×10 ³ lbf	40×10 ³ lbf			

FRONT VIEW 正视图

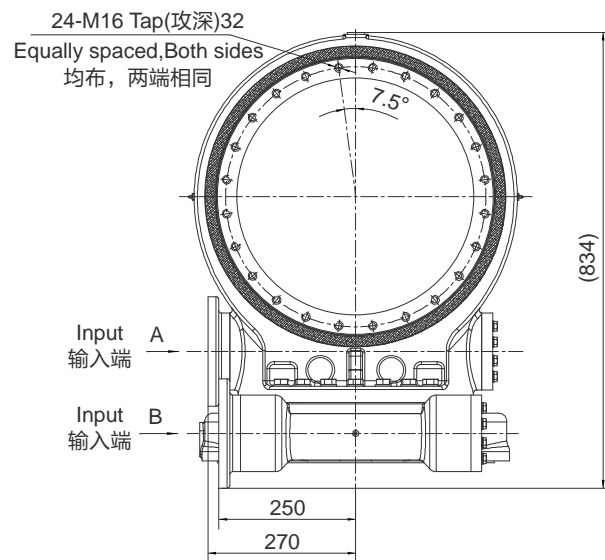

SIDE VIEW 侧视图

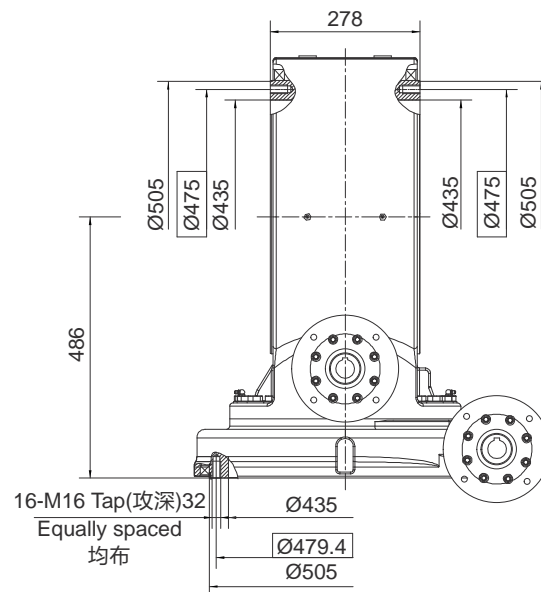

SPECIAL DESIGN BASE ON CUSTOMER'S REQUIREMENT
可根据顾客的要求进行非标设计

TOP VIEW 俯视图

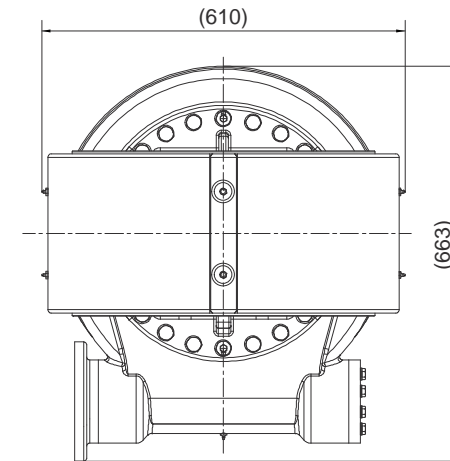

VIEW A A向视图

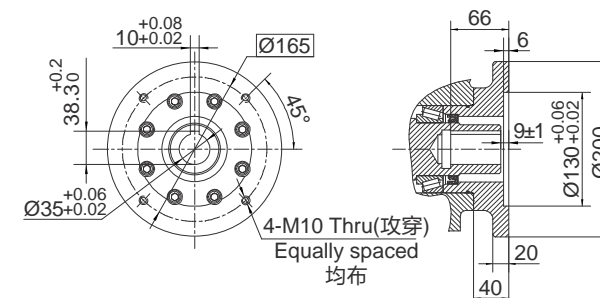

VIEW B B向视图

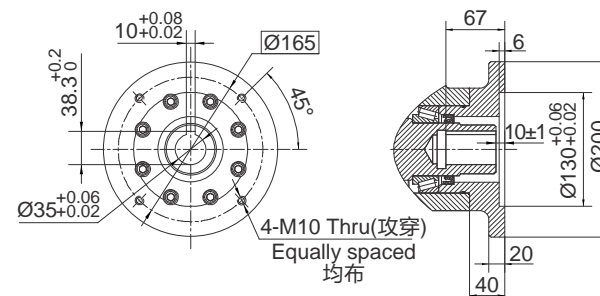

MOMENT LOAD CHART 承载力矩图

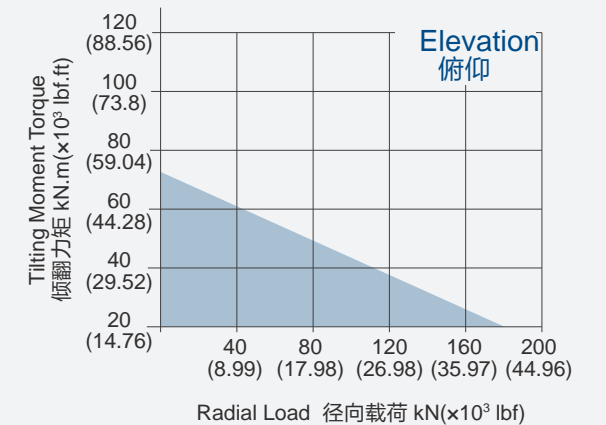
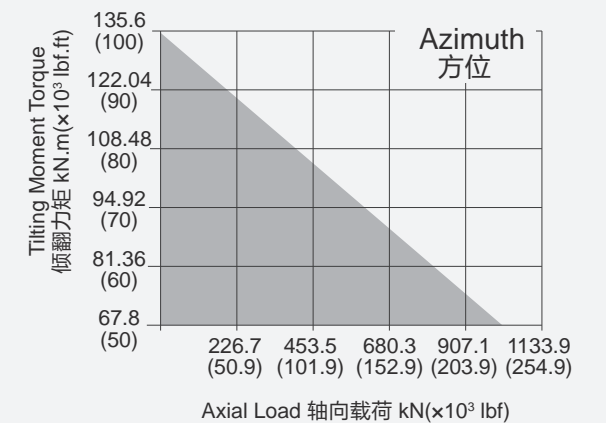

PLEASE BE SURE TO REMAIN UNDER THIS CURVE
选型时请确保实际载荷在曲线范围内

NOTICE 注意

- This drawing is just for your reference. 以上图纸仅供参考。
- This drawing is subject to change due to new design without prior notice. 本公司保留改进产品的权利而不再另行通知。

For further details on the full range of single axis Drive Slew Rings click [here](#)



Distributors for Australia & New Zealand
MOTION TECHNOLOGIES PTY LIMITED



24/22-30 Northumberland Road
Caringbah NSW 2229 Australia
Phone: (02) 9524 4782

sales@motiontech.com.au
www.motiontech.com.au

© 23/05/2023