

Modular Assembly System

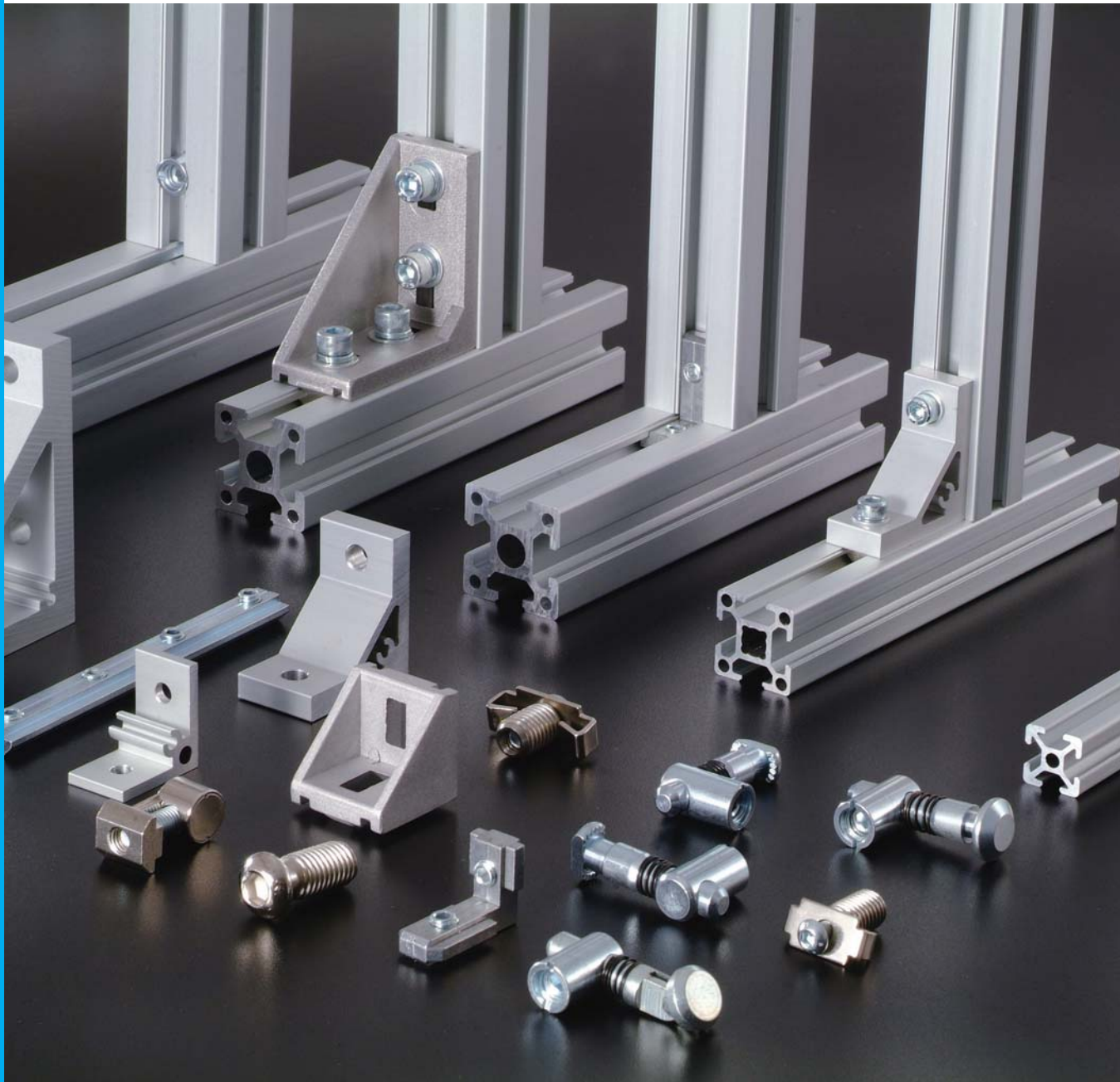

Modular Assembly System
模块化工业组装系统

Version 7.4



专业 专注 精益求精

Profession Devotion Keep Improving

经验丰富的工程师队伍；
专业的设备和多年的实践；
标准化的操作流程；
高素质的销售团队和以顾客为导向的服务宗旨；
美德乐为您提供的不仅仅是产品，更是工业领域的最前沿理念；
我们要您了解的不只是产品质量，更是一种服务态度。

Made in China;
Higher quality at unbeatable price;
Shipped directly pre-assembled to customers;
Converting any original design to MAT design, free of charge.

Try once, and you will never change!!!

What's inside...

Assembly Technology

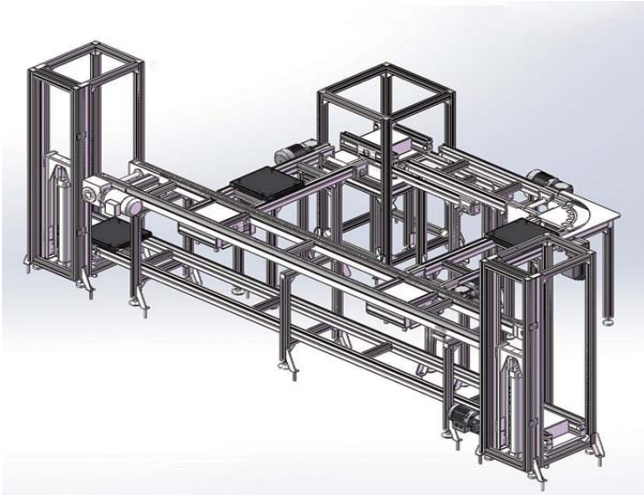

Technical Support 技术支持

- Complete product info
- CAD Models
- Quick & Easy configurator
- Calculation of profile deflection
- Drawing conversion for profiles
- Layout Designer for fast, easy planning
- 完整的产品信息
- CAD图库
- 装配简单便捷
- 型材变形量的计算
- 图纸的转换
- 规划简单快速



On-time, rapid delivery 准时，快速交货

- Availability of all components
- Pre-assembled modules, complete frames
- Prompt shipping and exemplary delivery reliability
- 配件充足
- 模块化组装
- 及时交付产品



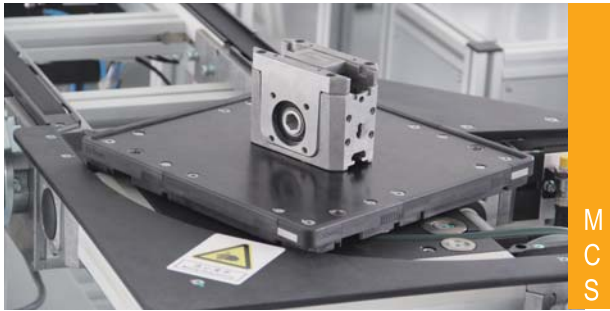

Modular Conveyor System(MCS) is mainly for pallet conveyor system. This system is widely used in new energy, car component production, pharmaceutical, electronics, tobacco, packing and other industries.

模块化输送系统主要指托盘输送系统。产品广泛地用于新能源、汽车零部件制造、医药、电子、烟草、包装等行业。



Modular Assembly System (MAS) is composed of industrial aluminum profiles and accessories. You can quickly find a solution for all tasks with the complete specification and variety of accessories from MAT.

模块化工业组系统由工业铝型材及其配件组成，型材规格齐全，附件多样化，可以快速组装成任意的结构形式。



Machine Guard System (MGS) is designed for customers with advanced guarding need. The special design of guarding profiles offer better appearance and unique fastening elements brings faster and safer connections.

机械防护系统是为了满足客户对防护的高级需求而独立设计的。防护型材的特殊设计令整体防护系统更加简洁美观，专用的紧固组件可实现快速和可靠的连接。



Stair and Platform System (SPS) is commonly used for overpass bridges over machinery and equipment. The assembly can be realized easily by simply fastening screws without any machine work. The system is very easy and convenient to use.

工业踏步及走台系统常用于机械上下扶梯及设备的跨线桥，无需特殊加工即可实现组装，方便快捷，内藏式锁紧结构，美观整洁。



Tubular Framing System (TFS) is a flexible modular system composed of special profile tubes and accessories to build a diverse range of flow racks and material shuttles. TFS is simple and quick to use, also low cost.

线棒柔性系统是由导管型材和其它附件组成的一种模块化柔性系统，可以组合成各种类型、规格、尺寸的工位器具和料架，制造简单迅速、低成本。



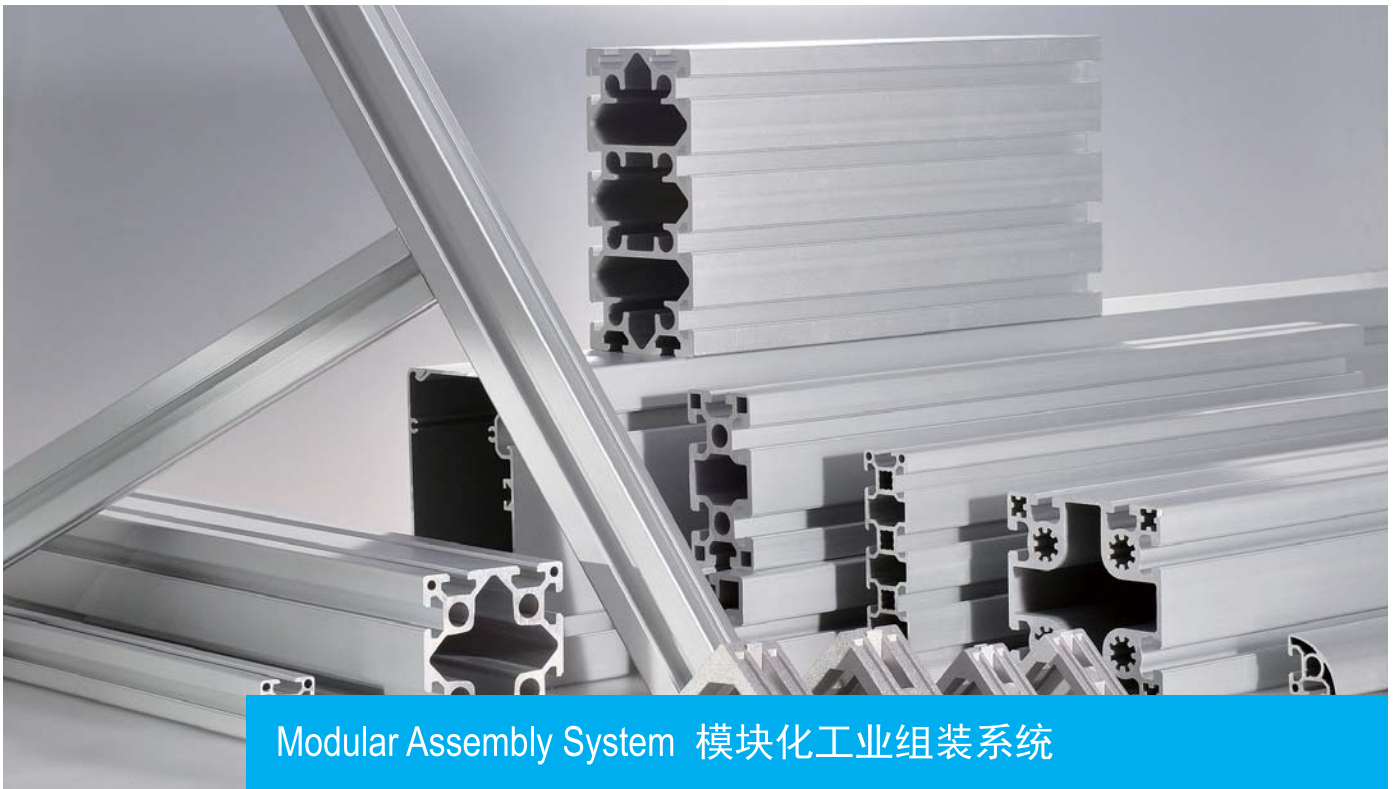

Modular Conveyor System
模块化输送系统



Modular Assembly System
模块化工业组装系统



Machine Guard System
机械防护系统



Stair and Platform System
工业踏步及走台系统



Tubular Framing System
线棒柔性系统



Modular Assembly System---
safe, quick, reliable

Use our comprehensive range
to effectively cut working hours and costs.

- Short planning times
- Faster construction
- Highly flexible conversion and extension options
- Reusable components
- Available worldwide

模块化组装系统特性-
安全、快捷、可靠。

全方位有效地节省工时和成本。

- 加工时间短
- 组装速度快
- 高度灵活性
- 可重复使用
- 全球销售



Machine guard frame for conveying equipment 输送设备防护框架



Special profile for clean room frame 洁净室专用框架型材



Lifting equipment frame 升降设备框架



Machine guard frame 防护框架



Working table 工作台



Protective barriers for machine 机器设备外围防护



Protective barriers for robot 机器人外围防护

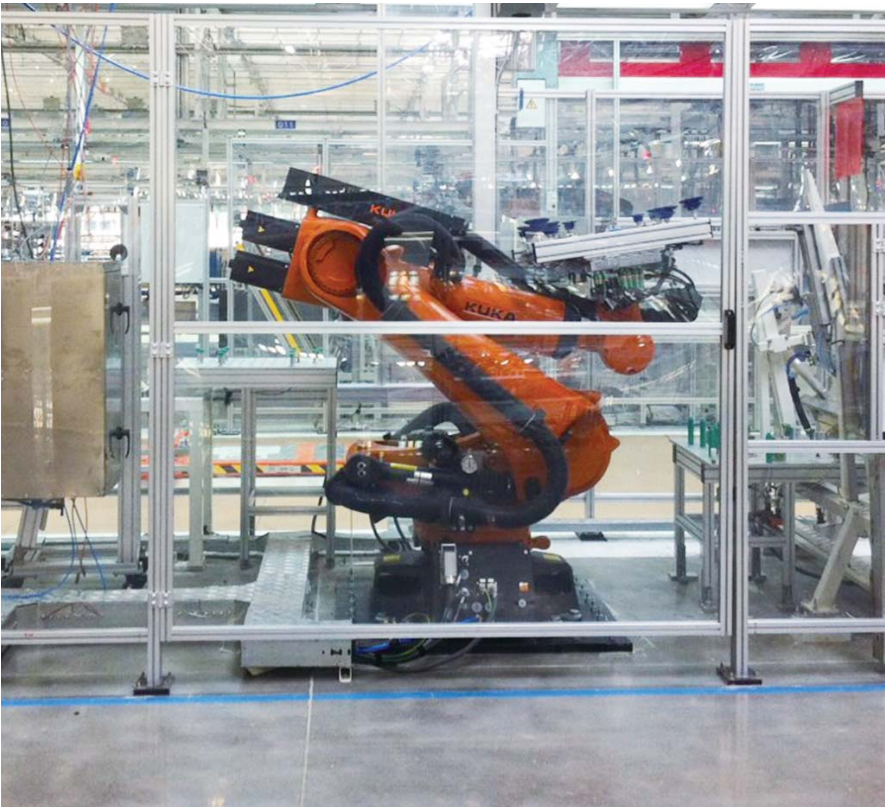

Protective barriers for robot 机器人外围防护



Protective barriers for machine 机器设备外围防护



Protective barriers for car assembly line 汽车生产线外围防护



Bridge for Sorting Machine 分拣设备过线梯



Bridge for Sorting Machine 分拣设备过线梯



Platform for Aerospace Equipment 航天设备载体



Bridge for Sorting Machine 分拣设备过线梯



Bridge for Sorting Machine 分拣设备过线梯



Maintenance Platform 设备维修梯



Bridge for Sorting Machine 分拣设备过线梯



Maintenance Platform 设备维修梯



Bridge for Sorting Machine 分拣设备过线梯



Arched Stairs for Aerospace Equipment 航天设备拱形梯

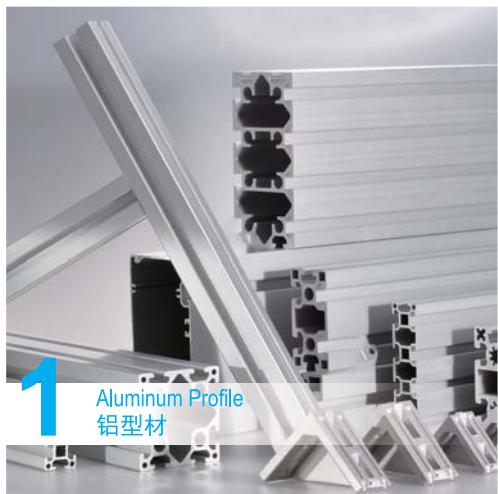

1 Aluminum Profile
铝型材



P. 1-06...



P. 1-07...



P. 1-08...



P. 1-11...



P. 1-17...



P. 1-21...



P. 1-22...



P. 1-23...



P. 1-24...



2 Fastening Elements
紧固件



P. 2-02...



P. 2-03...



P. 2-04...



P. 2-05...



P. 2-06...



P. 2-07...



P. 2-08...



3 Connecting Elements
连接件



P. 3-03...



P. 3-07...



P. 3-12...



P. 3-31...



P. 3-32...



P. 3-34...



P. 3-40...



P. 3-41...



P. 3-42...



P. 3-43...



P. 3-44...



4 Profile Accessories
型材附件



P. 4-02...



P. 4-04...



5 Floor Elements
地面组件



P. 5-02...



P. 5-03...



P. 5-04...



P. 5-07...



P. 5-08...



P. 5-10...



P. 5-11...



P. 5-14...



P. 5-15...



P. 5-16...



P. 5-17...



P. 5-18...



6 Panel Installation Elements
板材组件



P. 6-02...



P. 6-03...



P. 6-04...



P. 6-05...



7 Door and Window Elements
门窗组件



P. 7-02...



P. 7-03...



P. 7-04...



P. 7-05...



P. 7-06...



P. 7-09...



P. 7-10...

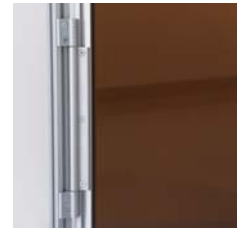

P. 7-11...



P. 7-12...



P. 7-13...



P. 7-14...



P. 7-16...



P. 7-17...



8 Additional Accessories
其他组件



P. 8-02...



P. 8-03...



P. 8-04...



P. 8-05...



P. 8-07...



P. 8-09...



1.11-1.41

Strut Profile
基础框架型材

Angle Profile
角铝型材

Conduit Profile
线槽型材

1

Aluminum Profile
铝型材



P. 1-06



P. 1-23



P. 1-24

Technical Data
技术信息

Extruded aluminum profile as per GB5237-2008, surface satin anodized.
Standard length of delivery profiles are: 6000mm for delivery inside China, 5800mm for international shipment.
铝型材执行标准GB5237-2008。表面处理为阳极氧化，亚光表面。
标准供货长度：国内长度6米，国外长度5.8米。

Tensile Strength /抗拉强度: min.185N/mm²
Yield Strength /屈服强度: min.145N/mm²
Elongation /伸长率: 8%(T≤3.2mm) or 10%(T>3.2~25.0mm)
E-Module /弹性模量: approx.70,000N/mm²
Brinell Hardness /布氏硬度: HB 75 2.5/187.5
Coat Thickness /氧化膜厚度: ≥11μ

Bending Strength
变形量计算

For deflection calculation, refer to formulas as below:
公式中涉及到的变量：

f (mm): Deflection /变形量
F (N): Type of load /载荷
L (mm): Profile length /型材长度
I (cm⁴): Moment of inertia /惯性矩
E (N/mm²): Modular of elasticity /弹性模量

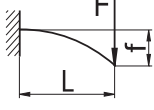
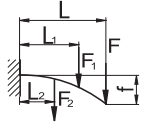
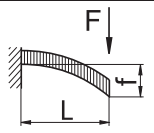
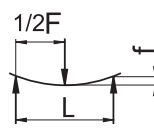
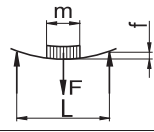
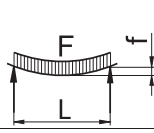
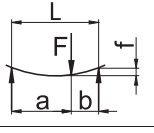
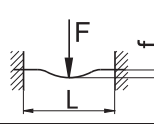
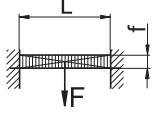
1		$f = \frac{F \cdot L^3}{3E \cdot I \cdot 10^4}$
2		$f = \frac{F \cdot L^3 + F_1 \cdot L_1^2 \cdot L + F_2 \cdot L_2^2 \cdot L}{3E \cdot I \cdot 10^4}$
3		$f = \frac{F \cdot L^3}{8E \cdot I \cdot 10^4}$
4		$f = \frac{F \cdot L^3}{48E \cdot I \cdot 10^4}$
5		$f = \frac{F \cdot L^3}{\left(48 + \frac{29m}{L}\right) \cdot E \cdot I \cdot 10^4}$
6		$f = \frac{5F \cdot L^3}{384E \cdot I \cdot 10^4}$
7		$f = \frac{F \cdot a^2 \cdot b^2}{3E \cdot I \cdot 10^4 \cdot L}$
8		$f = \frac{F \cdot L^3}{192E \cdot I \cdot 10^4}$
9		$f = \frac{F \cdot L^3}{384E \cdot I \cdot 10^4}$

Approximate determination of deflection
变形量速查表

Determinations of deflection:

变形量决定因素:

1. Type of load F in N
承载力 F(N)
2. Profile length L in mm
型材长度 L(mm)
3. Move cross point on the diagonal
承载力与型材长度的交点
4. Moment of inertia of selected profile I in cm⁴
所选型材惯性矩(cm⁴)
5. Cross point with the diagonal to be vertically extended to the bottom
从交点垂直延伸到底部的直线
6. Deflection f for the specific "Type of load" in mm
不同承受方式的变形量 f(mm)

Example:

示例:

1. F=2,000N
2. L=1,000mm
3. Move cross point on the diagonal
①与②的交点
4. I=80.8cm⁴ for profile 40x80, 6EH
(1.11.40.040080.06H)
I=80.8cm⁴选择惯性矩为80.8的40x80重型型材
(1.11.40.040080.06H)
5. Cross point with the diagonal to be vertically extended to the bottom
从点③沿斜线向上与④的延伸线对应的交点
6. Deflection f for the specific "Type of load" in mm
不同承重方式的变形量 f(mm)

- Type of load 1: f=9.5mm
一端固定负载: f=9.5mm
Type of load 4: f=0.6mm
两端支撑负载: f=0.6mm
Type of load 8: f=0.15mm
两端固定负载: f=0.15mm

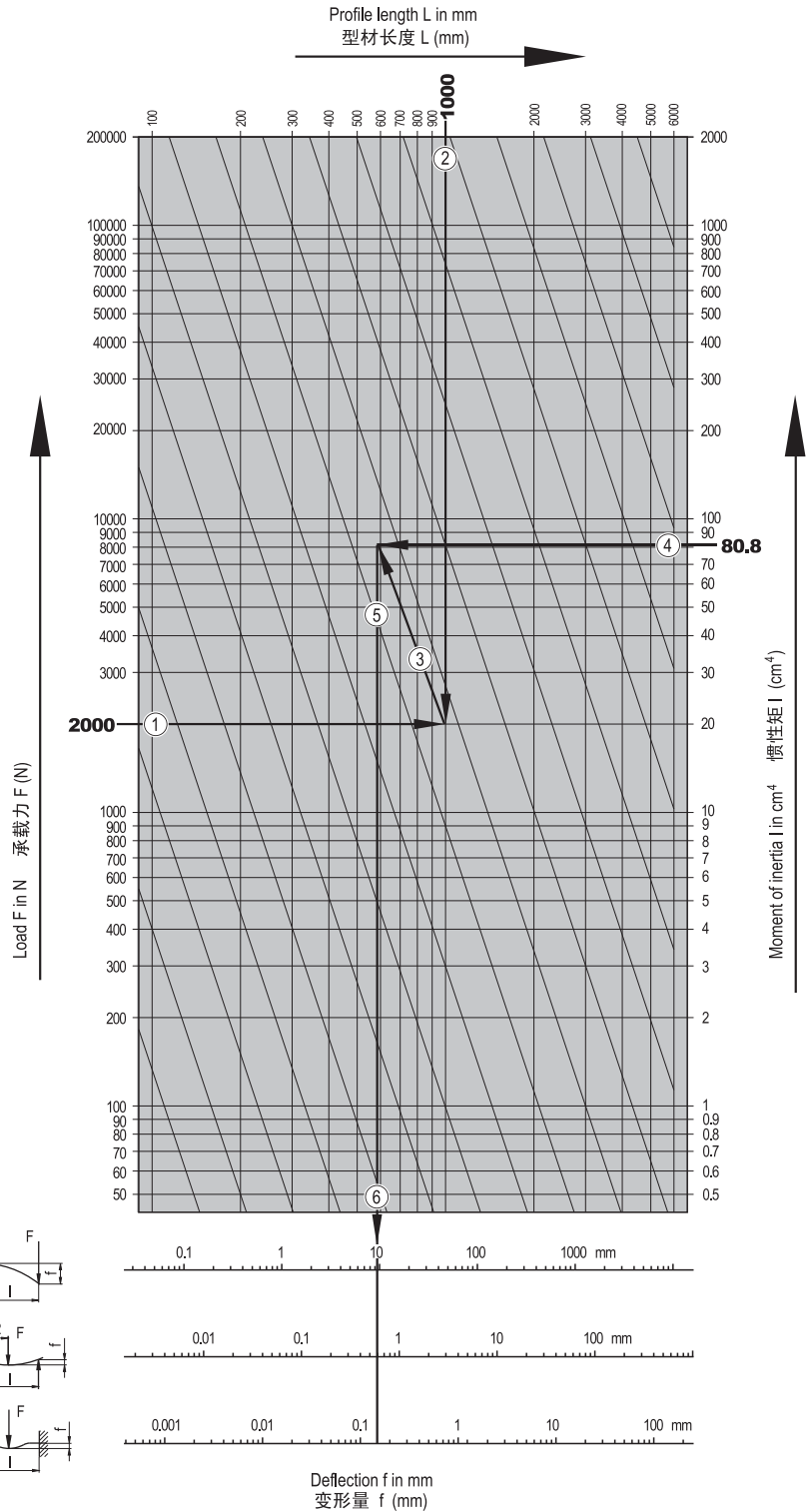

Type of load 1
一端固定负载

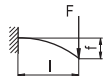

Type of load 4
两端支撑负载

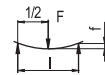

Type of load 8
两端固定负载

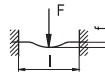

Profile Tolerance
型材公差

Flatness tolerance
平面度

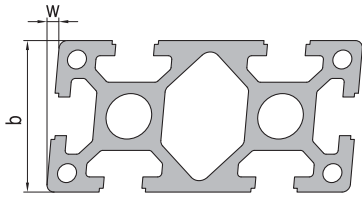

The flatness tolerance w (angular tolerance) refers to unequal sides to the shorter side of the angle, i.e. it is measured from the longer side.
平面度公差 w (角度公差)是指变形一边到型材短边的距离, 从长边处测量。

$b(\text{mm})$	$w(\text{mm})$
≤ 40	0.3
$>40\sim 80$	0.5
$>80\sim 180$	1.0

Straightness tolerance
直线度

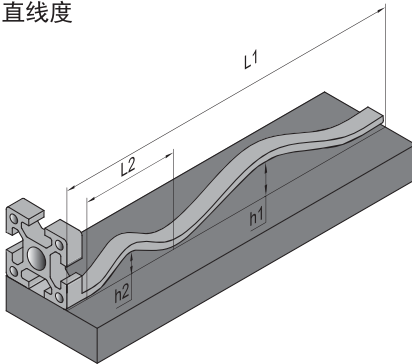

Putting the profile on a horizontal surface, the max bending height h_2 in any length of 30mm (L_2) is not more than 0.3mm ($L_2=300\text{mm}$, $h_2\leq 0.3\text{mm}$). Refer to the following table for the bending height h_1 of the full length profile (L_1).
型材水平放置, 任意位置的长度 $L_2=300\text{mm}$, 其弯曲变形高度 h_2 的最大值不超过0.3mm ($L_2=300\text{mm}$, $h_2\leq 0.3\text{mm}$)。型材全长 L_1 的弯曲变形高度 h_1 参照下表:

$L_1(\text{m})$	1	2	3	4	5	6
$h_1(\text{mm})$	0.7	1.4	2.1	2.8	3.5	4.2

Twist tolerance
扭曲度

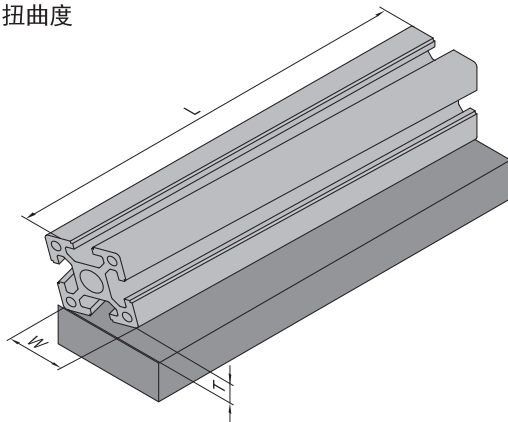

Putting the profile on a horizontal surface, if the end tilts due to twist, the twist height (T) could be calculated according to the formula below:
型材水平放置, 若因扭曲造成端面翘起, 扭曲的高度(T)可根据以下公式计算。

$W(\text{mm})$	$T(\text{mm})$	
	$L\leq 1\text{m}$	$L> 1\text{m}$
≤ 40	$0.052 \times W$	$0.123 \times W$
$>40\sim 80$	$0.026 \times W$	$0.087 \times W$
$80\sim 180$	$0.017 \times W$	$0.052 \times W$

T Slot Symbol
T形槽符号

Parts compatible with T slot symbolized and incompatible with faded symbolized as below.
组件若适合安装到此T形槽上，T形槽用深色表示；反之则用浅色示例如下：

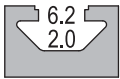
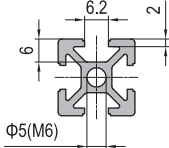
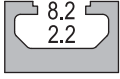
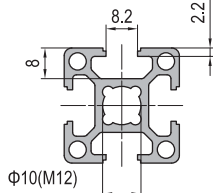
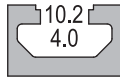
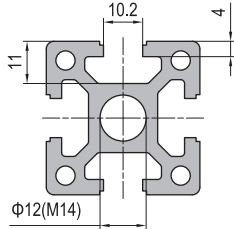
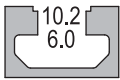
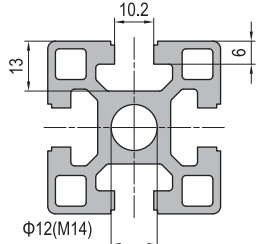

T Slot Symbol T形槽符号	Cross Section 型材截面	Core Hole Φ 中心孔 Φ	Slot Width 槽宽	Slot Depth 槽深	Wall Thickness 壁厚	Profile Group 型材系列
		5.0	6.2	6.0	2.0	PG15 PG20
		10.0	8.2	8.0	2.2	PG30
		12.0	10.2	11.0	4.0	PG40
		12.0	10.2	13.0	6.0	PG45 PG50 PG60

Machining Symbol
加工符号

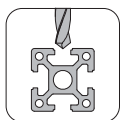

Drilling
需钻孔



Angle cutting
需切割角度

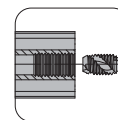

Thread tapping
需攻丝

Strut Profile PG15
基础框架型材 15系列



15x15 2 slots
15x15 2槽



15x30 3 slots
15x30 3槽

Strut profile PG15 featuring 6mm T-slot is designed for constructing light weight assemblies.
基础框架型材15系列，槽宽6mm，主要应用于轻负载结构。

15x15 2 slots
15x15 2槽

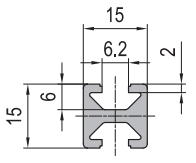

15x30 3 slots
15x30 3槽

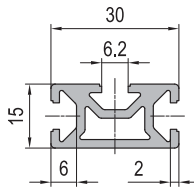

Description 产品描述	Moment of Inertia 惯性矩 $I_x(\text{cm}^4)$	Moment of Inertia 惯性矩 $I_y(\text{cm}^4)$	Moment of Resistance 弯矩 $W_x(\text{cm}^3)$	Moment of Resistance 弯矩 $W_y(\text{cm}^3)$	Mass 重量 (kg/m)	Part No. 订购编号
Strut Profile PG15 15x15 2 slots 基础框架型材 15系列 15x15 2槽	0.2	0.4	0.3	0.5	0.4	1.11.15.015015.02
Strut Profile PG15 15x30 3 slots 基础框架型材 15系列 15x30 3槽	0.7	1.8	0.8	1.2	0.6	1.11.15.015030.03

Connector selection
推荐连接件



Angle Profile Bracket
挤压角铝 P. 3-12



Inner Bracket
槽内直角件 P. 3-31



Linear Bar Connector
槽内直线件 P. 3-32



Strut Profile PG20
基础框架型材 20系列



20x20 R90 2 slots
20x20 R90 2槽

20x20 4 slots
20x20 4槽

20x40 6 slots
20x40 6槽

20x60 8 slots
20x60 8槽

20x80 10 slots
20x80 10槽

40x40 8 slots
40x40 8槽

Strut profile PG20 featuring 6mm T-slot is designed for constructing light weight assemblies.
基础框架型材20系列，槽宽6mm，主要应用于轻负载结构。

20x20 R90 2 slots
20x20 R90 2槽

20x20 4 slots
20x20 4槽

20x40 6 slots
20x40 6槽

20x60 8 slots
20x60 8槽

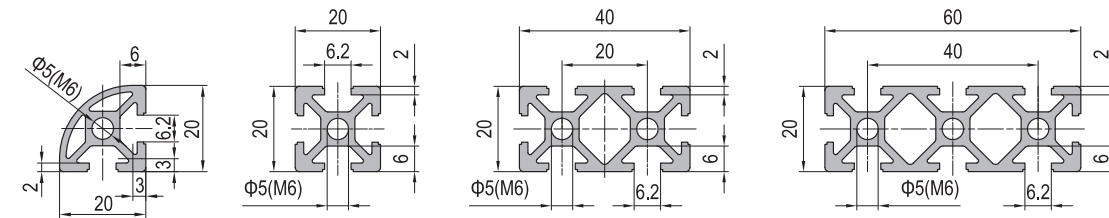



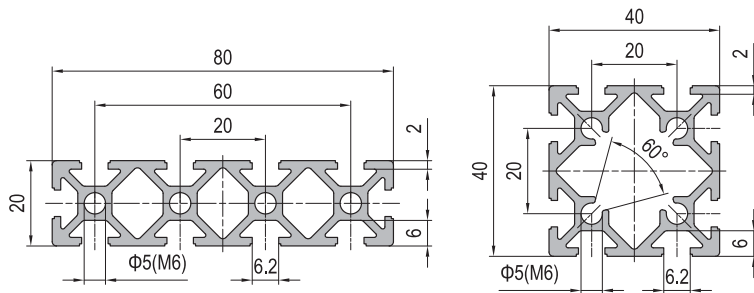

20x80 10 slots
20x80 10槽

40x40 8 slots
40x40 8槽



Connector selection
推荐连接件

-  Die Cast Bracket P. 3-07
压铸角铝
-  Angle Profile Bracket P. 3-12
挤压角铝
-  Inner Bracket P. 3-31
槽内直角件
-  Linear Bar Connector P. 3-32
槽内直线件

Description 产品描述	Moment of Inertia 惯性矩 Ix(cm ⁴)	Moment of Inertia 惯性矩 Iy(cm ⁴)	Moment of Resistance 弯矩 Wx(cm ³)	Moment of Resistance 弯矩 Wy(cm ³)	Mass 重量 (kg/m)	Part No. 订购编号
Strut Profile PG20 20x20 R90 2 slots 基础框架型材 20系列 20x20 R90 2槽	0.6	0.6	0.5	0.5	0.45	1.11.20.020020.R90.02
Strut Profile PG20 20x20 4 slots 基础框架型材 20系列 20x20 4槽	0.8	0.8	0.8	0.8	0.5	1.11.20.020020.04
Strut Profile PG20 20x40 6 slots 基础框架型材 20系列 20x40 6槽	1.4	5.1	1.4	2.5	0.9	1.11.20.020040.06
Strut Profile PG20 20x60 8 slots 基础框架型材 20系列 20x60 8槽	2.0	15.8	2.0	5.3	1.3	1.11.20.020060.08
Strut Profile PG20 20x80 10 slots 基础框架型材 20系列 20x80 10槽	2.6	35.9	2.6	9.0	1.7	1.11.20.020080.10
Strut Profile PG20 40x40 8 slots 基础框架型材 20系列 40x40 8槽	8.9	8.9	4.5	4.5	1.3	1.11.20.040040.08

Strut Profile PG30
基础框架型材 30系列



15x90 7 slots
15x90 7槽



30x30 R45 2 slots
30x30 R45 2槽



30x30 R90 2 slots
30x30 R90 2槽



30x30 2 slots Type A
30x30 2槽 A型



30x30 2 slots Type B
30x30 2槽 B型



30x30 3 slots
30x30 3槽



30x30 4 slots Light
30x30 4槽 轻型



30x30 4 slots
30x30 4槽



30x60 6 slots
30x60 6槽



30x90 8 slots
30x90 8槽



30x120 10 slots
30x120 10槽



30x150 12 slots
30x150 12槽



60x60 8 slots
60x60 8槽



60x60 L 8 slots
60x60 L形 8槽



60x120 12 slots
60x120 12槽

Strut profile PG30 featuring 8mm T-slot is designed for constructing medium weight assemblies such as machine structure frame, trolley, work station, partition and display frames etc.

基础框架型材30系列，槽宽8mm，适用于中度负载结构：机器结构框架，物料车，工作台，工厂车间隔段，展示架等。

Connector selection

推荐连接件



Anchor Connector P. 3-03
锚式连接销



Die Cast Bracket P. 3-08
压铸角铝



Angle Profile Bracket P. 3-15
挤压角铝



Inner Bracket P. 3-31
槽内直角件



Linear Bar Connector P. 3-32
槽内直线件



Screw Connector P. 3-42
大螺栓



Strut Profile PG30
基础框架型材 30系列

15x90 7 slots
15x90 7槽

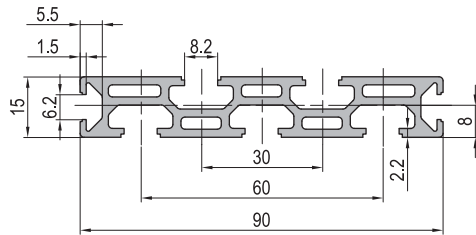

30x30 R45 2 slots
30x30 R45 2槽

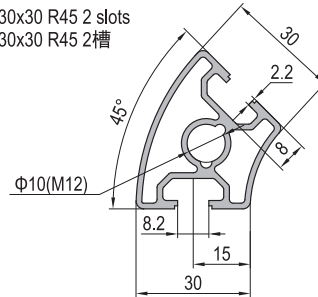

30x30 R90 2 slots
30x30 R90 2槽

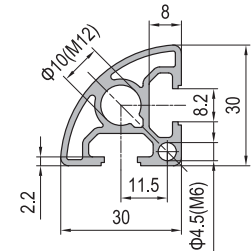

30x30 2 slots Type A
30x30 2槽 A型

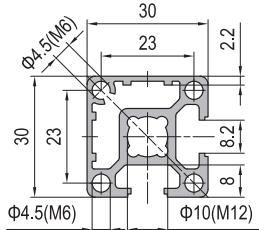

30x30 2 slots Type B
30x30 2槽 B型

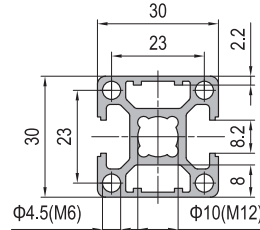

30x30 3 slots
30x30 3槽

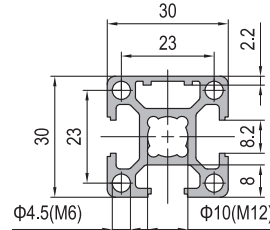

30x30 4 slots Light
30x30 4槽 轻型

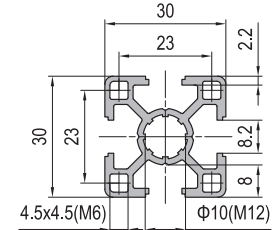

30x30 4 slots
30x30 4槽

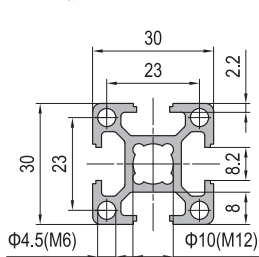

30x60 6 slots
30x60 6槽

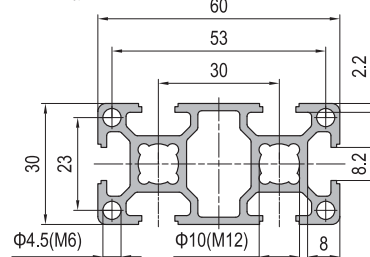

30x90 8 slots
30x90 8槽

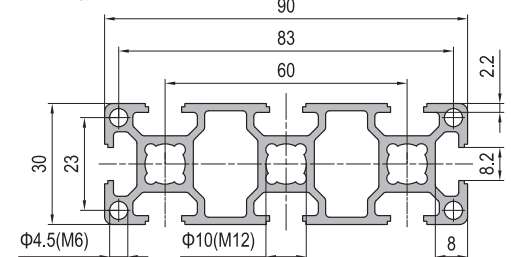

Description 产品描述	Moment of Inertia 惯性矩 Ix(cm ⁴)	Moment of Inertia 惯性矩 Iy(cm ⁴)	Moment of Resistance 弯矩 Wx(cm ³)	Moment of Resistance 弯矩 Wy(cm ³)	Mass 重量 (kg/m)	Part No. 订购编号
Strut Profile PG30 15x90 7 slots 基础框架型材 30系列 15x90 7槽	1.4	40.4	1.9	9.0	1.5	1.11.30.015090.07
Strut Profile PG30 30x30 R45 2 slots 基础框架型材 30系列 30x30 R45 2槽	4.2	3.1	2.4	1.7	0.852	1.11.30.030030.R45.02 New!
Strut Profile PG30 30x30 R90 2 slots 基础框架型材 30系列 30x30 R90 2槽	2.0	2.0	1.5	1.5	0.8	1.11.30.030030.R90.02
Strut Profile PG30 30x30 2 slots Type A 基础框架型材 30系列 30x30 2槽 A型	2.9	2.9	2.0	2.0	0.9	1.11.30.030030.02A
Strut Profile PG30 30x30 2 slots Type B 基础框架型材 30系列 30x30 2槽 B型	2.8	3.2	1.9	2.1	0.9	1.11.30.030030.02B
Strut Profile PG30 30x30 3 slots 基础框架型材 30系列 30x30 3槽	3.0	2.9	2.0	1.9	0.9	1.11.30.030030.03
Strut Profile PG30 30x30 4 slots Light 基础框架型材 30系列 30x30 4槽 轻型	2.6	2.6	1.8	1.8	0.8	1.11.30.030030.04L
Strut Profile PG30 30x30 4 slots 基础框架型材 30系列 30x30 4槽	2.9	2.9	2.0	2.0	0.9	1.11.30.030030.04
Strut Profile PG30 30x60 6 slots 基础框架型材 30系列 30x60 6槽	5.3	19.9	3.5	6.7	1.6	1.11.30.030060.06
Strut Profile PG30 30x90 8 slots 基础框架型材 30系列 30x90 8槽	7.7	62.0	5.1	13.8	2.2	1.11.30.030090.08

Strut Profile PG30
基础框架型材 30系列

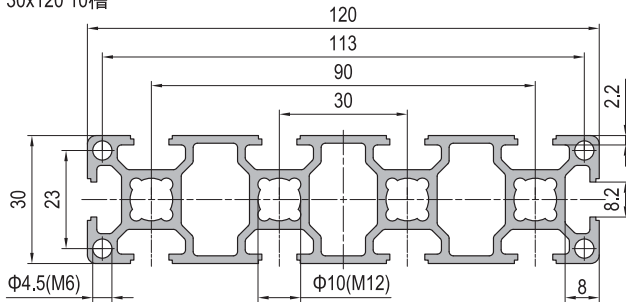
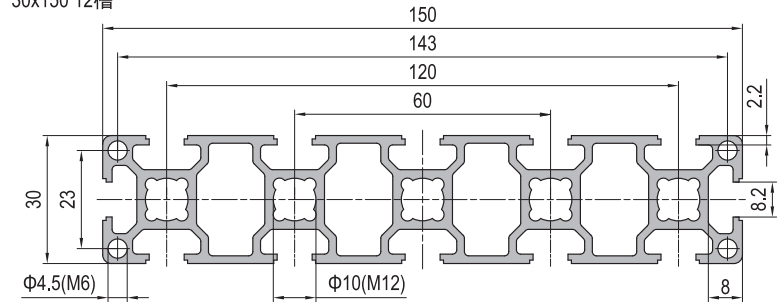
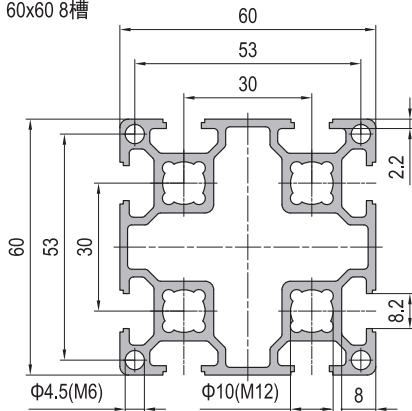
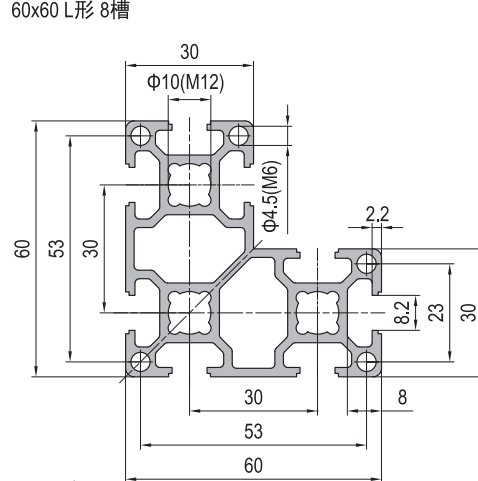
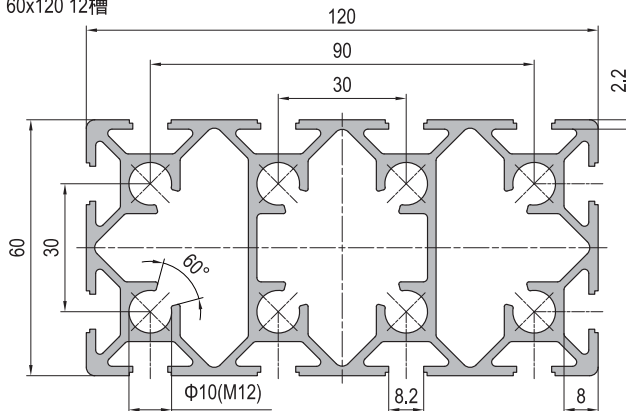
 30x120 10 slots
 30x120 10槽

 30x150 12 slots
 30x150 12槽

 60x60 8 slots
 60x60 8槽

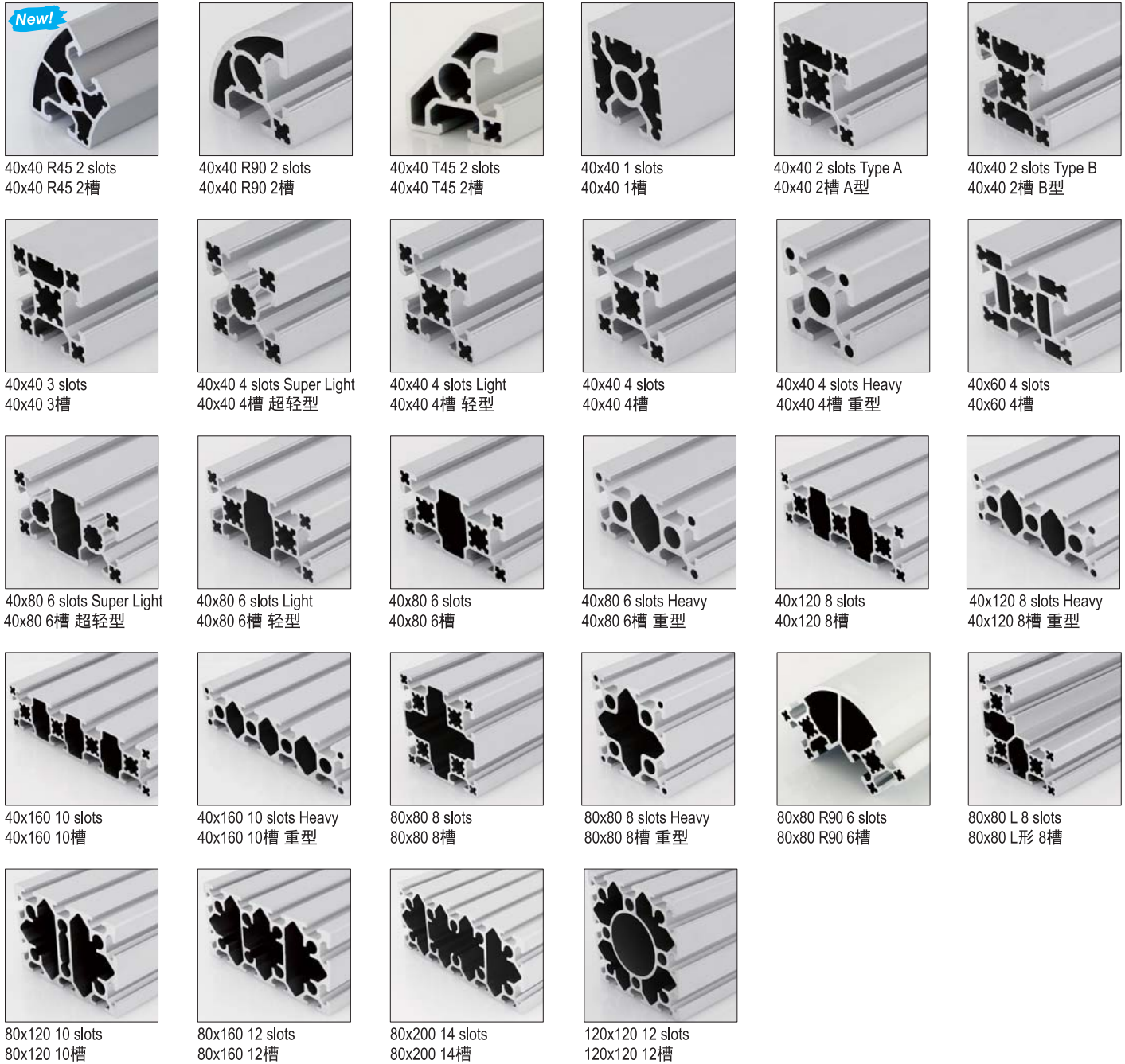
 60x60 L 8 slots
 60x60 L形 8槽

 60x120 12 slots
 60x120 12槽

Description 产品描述	Moment of Inertia 惯性矩 Ix(cm ⁴)	Moment of Inertia 惯性矩 Iy(cm ⁴)	Moment of Resistance 弯矩 Wx(cm ³)	Moment of Resistance 弯矩 Wy(cm ³)	Mass 重量 (kg/m)	Part No. 订购编号
Strut Profile PG30 30x120 10 slots 基础框架型材 30系列 30x120 10槽	10.1	139.9	6.7	23.3	2.9	1.11.30.030120.10
Strut Profile PG30 30x150 12 slots 基础框架型材 30系列 30x150 12槽	12.5	264.4	8.3	35.3	3.4	1.11.30.030150.12
Strut Profile PG30 60x60 8 slots 基础框架型材 30系列 60x60 8槽	35.3	35.3	11.8	11.8	2.5	1.11.30.060060.08
Strut Profile PG30 60x60 L 8 slots 基础框架型材 30系列 60x60 L形 8槽	26.4	26.4	10.4	10.4	2.3	1.11.30.060060L.08
Strut Profile PG30 60x120 12 slots 基础框架型材 30系列 60x120 12槽	74.7	252.6	24.9	42.1	4.8	1.11.30.060120.12

Strut Profile PG40
基础框架型材 40系列



Strut profile PG40 featuring 10mm T-slot is designed for constructing medium or heavy weight assemblies, such as machine structure frame, trolley, work station, partition and display frames etc. (Profile PG40 is frequently used).

基础框架型材40系列, 槽宽10mm, 适用于中度负载或重负载结构: 机器结构框架, 物料车, 工作台, 工厂车间隔段, 展示架等, 是应用最为广泛的型材系列。

Connector selection

推荐连接件

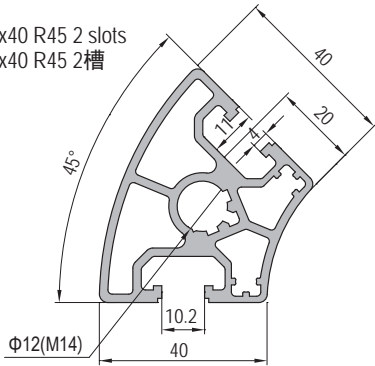
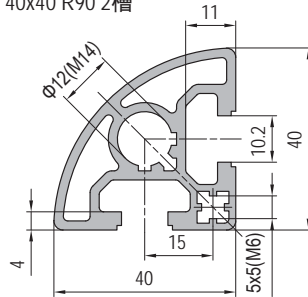
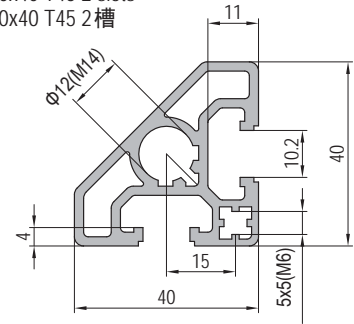
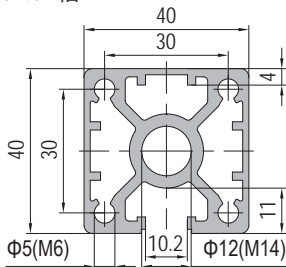
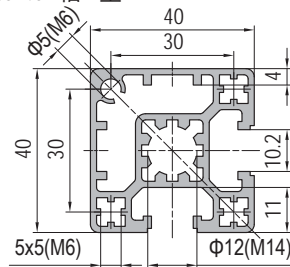
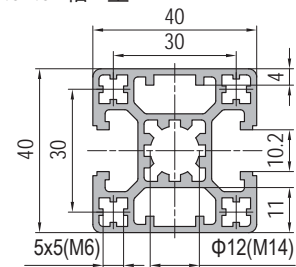
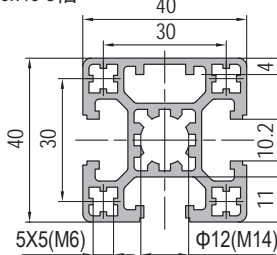
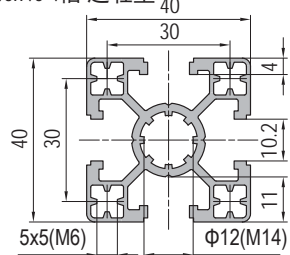
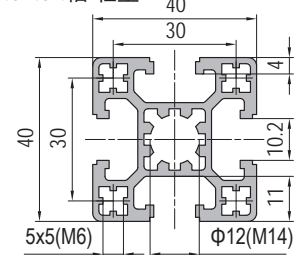

Strut Profile PG40
基础框架型材 40系列

 40x40 R45 2 slots
 40x40 R45 2槽

 40x40 R90 2 slots
 40x40 R90 2槽

 40x40 T45 2 slots
 40x40 T45 2槽

 40x40 1 slot
 40x40 1槽

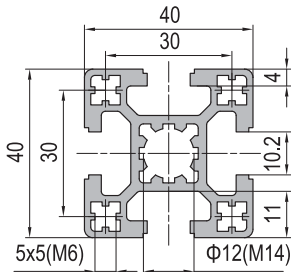
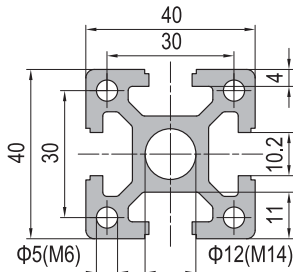
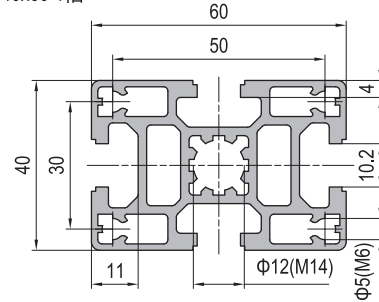
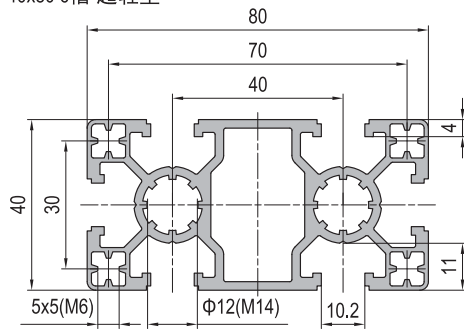
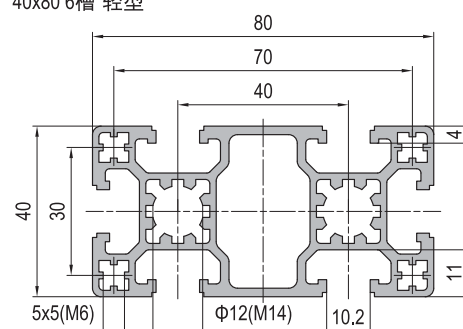
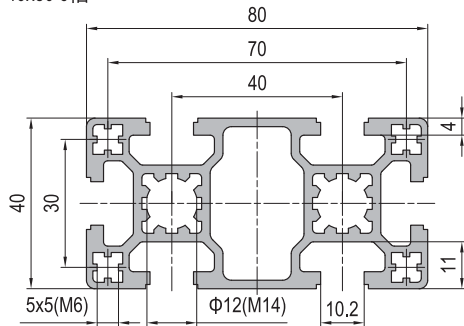
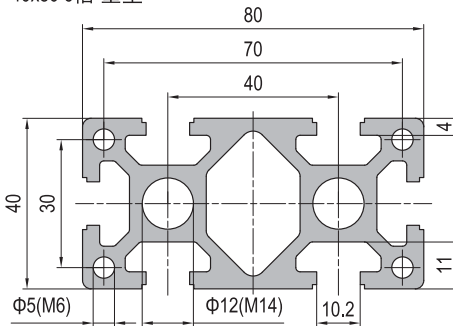
 40x40 2 slots Type A
 40x40 2槽 A型

 40x40 2 slots Type B
 40x40 2槽 B型

 40x40 3 slots
 40x40 3槽

 40x40 4 slots Super Light
 40x40 4槽 超轻型

 40x40 4 slots Light
 40x40 4槽 轻型

Description 产品描述	Moment of Inertia 惯性矩 $I_x(\text{cm}^4)$	Moment of Inertia 惯性矩 $I_y(\text{cm}^4)$	Moment of Resistance 弯矩 $W_x(\text{cm}^3)$	Moment of Resistance 弯矩 $W_y(\text{cm}^3)$	Mass 重量 (kg/m)	Part No. 订购编号
Strut Profile PG40 40x40 R45 slots 基础框架型材 40系列 40x40 R45 2槽	13.6	10.4	5.9	4.2	1.7	1.11.40.040040.R45.02 New!
Strut Profile PG40 40x40 R45 slots 基础框架型材 40系列 40x40 R90 2槽	6.5	6.5	3.7	3.7	1.3	1.11.40.040040.R90.02
Strut Profile PG40 40x40 T45 2 slots 基础框架型材 40系列 40x40 T45 2槽	6.5	6.5	3.25	3.25	1.21	1.11.40.040040.T45.02
Strut Profile PG40 40x40 1 slot 基础框架型材 40系列 40x40 1槽	10.4	10.1	5.2	5.0	1.68	1.11.40.040040.01
Strut Profile PG40 40x40 2 slots Type A 基础框架型材 40系列 40x40 2槽 A型	9.6	9.6	4.5	4.5	1.5	1.11.40.040040.02A
Strut Profile PG40 40x40 2 slots Type B 基础框架型材 40系列 40x40 2槽 B型	9.6	8.6	4.8	4.3	1.5	1.11.40.040040.02B
Strut Profile PG40 40x40 3 slots 基础框架型材 40系列 40x40 3槽	9.1	8.6	4.5	4.3	1.5	1.11.40.040040.03
Strut Profile PG40 40x40 4 slots Super Light 基础框架型材 40系列 40x40 4槽 超轻型	7.3	7.3	3.6	3.6	1.3	1.11.40.040040.04SL
Strut Profile PG40 40x40 4 slots Light 基础框架型材 40系列 40x40 4槽 轻型	8.6	8.6	4.3	4.3	1.5	1.11.40.040040.04L



Strut Profile PG40
基础框架型材 40系列

 40x40 4 slots
 40x40 4槽

 40x40 4 slots Heavy
 40x40 4槽 重型

 40x60 4 slots
 40x60 4槽

 40x80 6 slots Super Light
 40x80 6槽 超轻型

 40x80 6 slots Light
 40x80 6槽 轻型

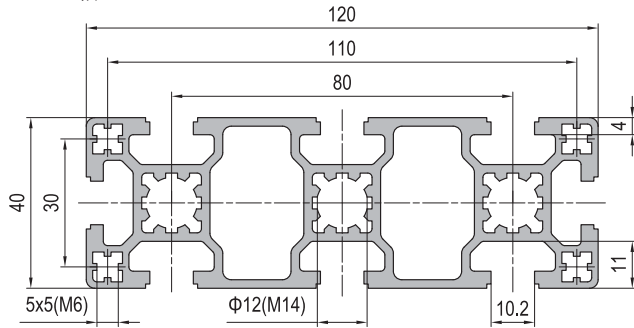
 40x80 6 slots
 40x80 6槽

 40x80 6 slots Heavy
 40x80 6槽 重型

Description 产品描述	Moment of Inertia 惯性矩 Ix(cm ⁴)	Moment of Inertia 惯性矩 Iy(cm ⁴)	Moment of Resistance 弯矩 Wx(cm ³)	Moment of Resistance 弯矩 Wy(cm ³)	Mass 重量 (kg/m)	Part No. 订购编号
Strut Profile PG40 40x40 4 slots 基础框架型材 40系列 40x40 4槽	9.1	9.1	4.6	4.6	1.6	1.11.40.040040.04
Strut Profile PG40 40x40 4 slots Heavy 基础框架型材 40系列 40x40 4槽 重型	11.5	11.5	5.8	5.8	2.0	1.11.40.040040.04H
Strut Profile PG40 40x60 4 slots 基础框架型材 40系列 40x60 4槽	13.3	27.6	6.6	9.2	2.3	1.11.40.040060.04
Strut Profile PG40 40x80 6 slots Super Light 基础框架型材 40系列 40x80 6槽 超轻型	14.3	52.0	7.2	13.0	2.3	1.11.40.040080.06SL
Strut Profile PG40 40x80 6 slots Light 基础框架型材 40系列 40x80 6槽 轻型	15.8	59.1	7.9	14.8	2.5	1.11.40.040080.06L
Strut Profile PG40 40x80 6 slots 基础框架型材 40系列 40x80 6槽	16.6	63.2	8.3	15.8	2.7	1.11.40.040080.06
Strut Profile PG40 40x80 6 slots Heavy 基础框架型材 40系列 40x80 6槽 重型	22.2	80.8	11.1	20.2	3.6	1.11.40.040080.06H



Strut Profile PG40
基础框架型材 40系列

40x120 8 slots
40x120 8槽



40x120 8 slots Heavy
40x120 8槽 重型

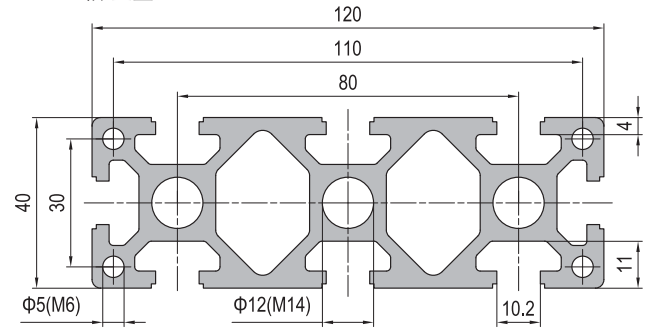

40x160 10 slots
40x160 10槽

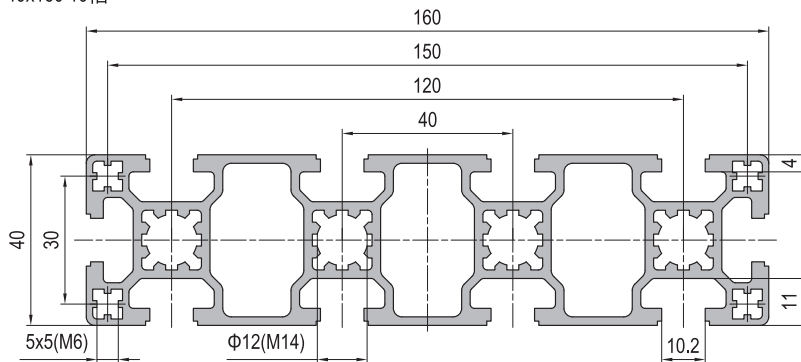

80x80 8 slots
80x80 8槽

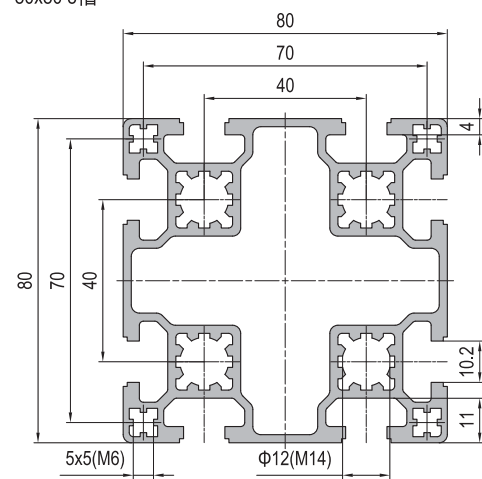

40x160 10 slots Heavy
40x160 10槽 重型

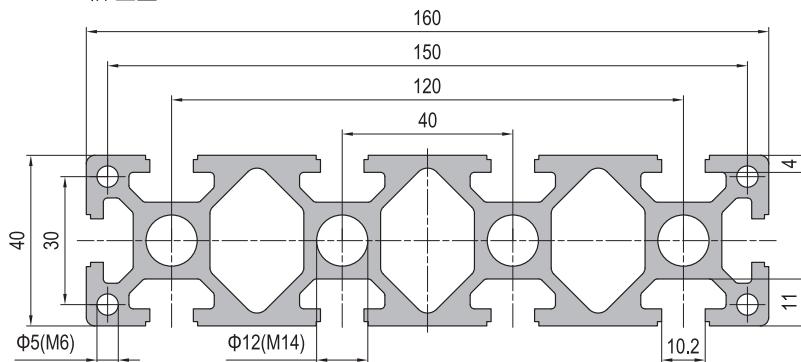

Description 产品描述	Moment of Inertia 惯性矩 Ix(cm ⁴)	Moment of Inertia 惯性矩 Iy(cm ⁴)	Moment of Resistance 弯矩 Wx(cm ³)	Moment of Resistance 弯矩 Wy(cm ³)	Mass 重量 (kg/m)	Part No. 订购编号
Strut Profile PG40 40x120 8 slots 基础框架型材 40系列 40x120 8槽	24.1	194.8	12.1	32.5	3.8	1.11.40.040120.08
Strut Profile PG40 40x120 8 slots Heavy 基础框架型材 40系列 40x120 8槽 重型	33.0	255.3	16.5	42.6	5.2	1.11.40.040120.08H
Strut Profile PG40 40x160 10 slots 基础框架型材 40系列 40x160 10槽	31.6	435.7	15.8	54.5	4.8	1.11.40.040160.10
Strut Profile PG40 40x160 10 slots Heavy 基础框架型材 40系列 40x160 10槽 重型	43.7	582.2	21.8	72.8	6.8	1.11.40.040160.10H
Strut Profile PG40 80x80 8 slots 基础框架型材 40系列 80x80 8槽	109.9	109.9	27.5	27.5	4.2	1.11.40.080080.08

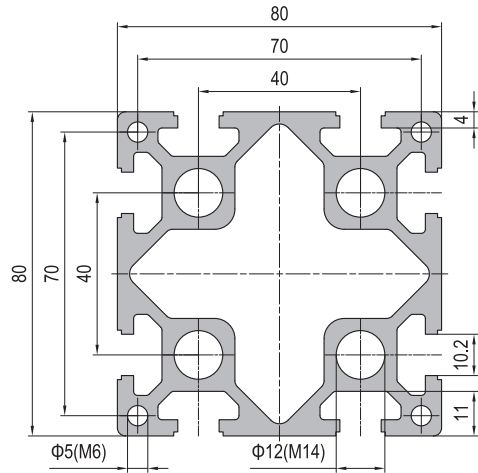
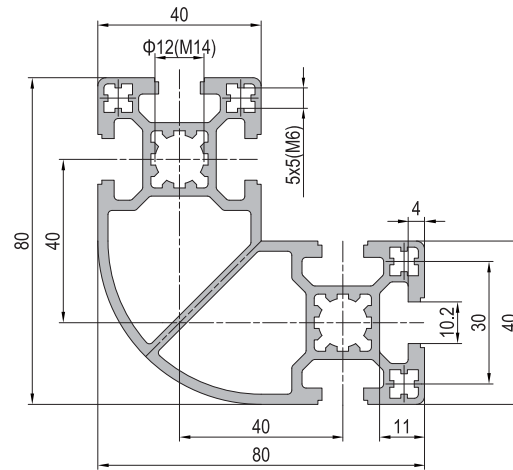
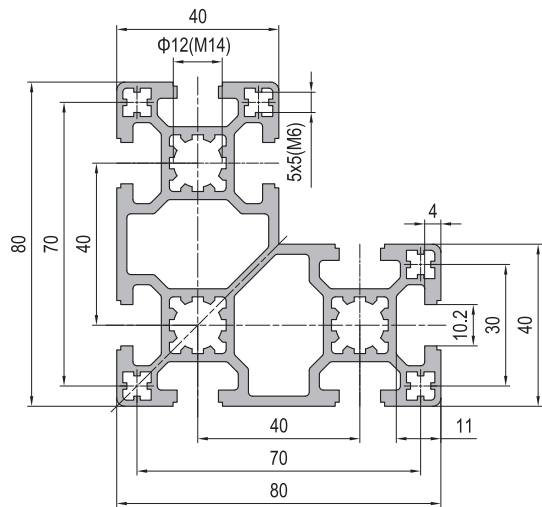
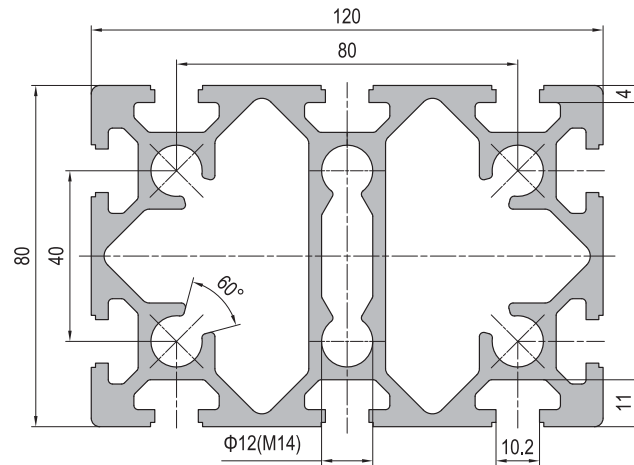

Strut Profile PG40
基础框架型材 40系列

 80x80 8 slots Heavy
 80x80 8槽 重型

 80x80 R90 6 slots
 80x80 R90 6槽

 80x80 L 8 slots
 80x80 L形 8槽

 80x120 10 slots
 80x120 10槽

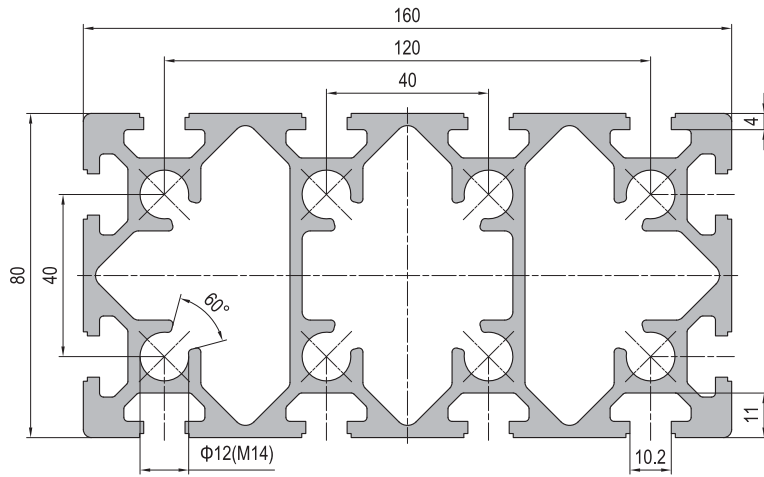
Description 产品描述	Moment of Inertia 惯性矩 Ix(cm ⁴)	Moment of Inertia 惯性矩 Iy(cm ⁴)	Moment of Resistance 弯矩 Wx(cm ³)	Moment of Resistance 弯矩 Wy(cm ³)	Mass 重量 (kg/m)	Part No. 订购编号
Strut Profile PG40 80x80 8 slots Heavy 基础框架型材 40系列 80x80 8槽 重型	148.2	148.2	37.1	37.1	5.7	1.11.40.080080.08H
Strut Profile PG40 80x80 R90 6 slots 基础框架型材 40系列 80x80 R90 6槽	73	73	20	20	3.4	1.11.40.080080.R90.06
Strut Profile PG40 80x80 L 8 slots 基础框架型材 40系列 80x80 L形 8槽	83.9	83.9	24.7	24.7	4.0	1.11.40.080080L.08
Strut Profile PG40 80x120 10 slots 基础框架型材 40系列 80x120 10槽	222.1	449.2	55.5	74.8	8.3	1.11.40.080120.10

Strut Profile PG40
基础框架型材 40系列

80x160 12 slots
80x160 12槽



120x120 12 slots
120x120 12槽

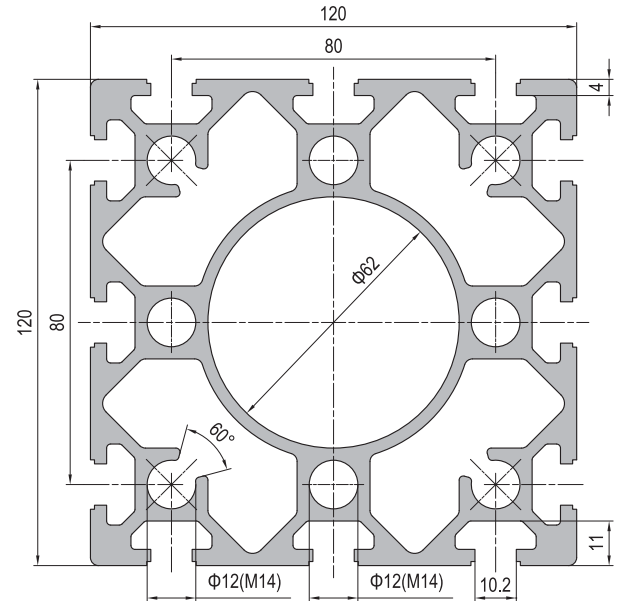

80x200 14 slots
80x200 14槽

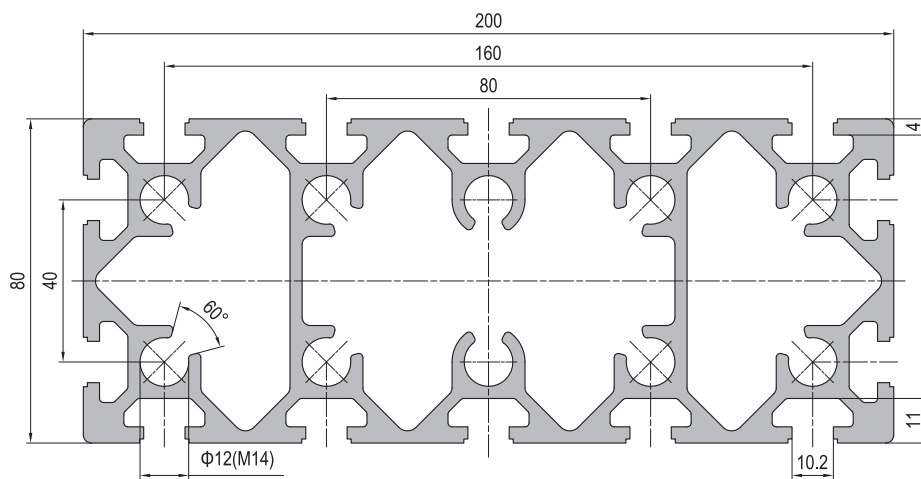

Description 产品描述	Moment of Inertia 惯性矩 $I_x(\text{cm}^4)$	Moment of Inertia 惯性矩 $I_y(\text{cm}^4)$	Moment of Resistance 弯矩 $W_x(\text{cm}^3)$	Moment of Resistance 弯矩 $W_y(\text{cm}^3)$	Mass 重量 (kg/m)	Part No. 订购编号
Strut Profile PG40 80x160 12 slots 基础框架型材 40系列 80x160 12槽	287.5	975.5	71.9	121.9	10.4	1.11.40.080160.12
Strut Profile PG40 80x200 14 slots 基础框架型材 40系列 80x200 14槽	353.1	1789.8	88.3	179.0	12.3	1.11.40.080200.14
Strut Profile PG40 120x120 12 slots 基础框架型材 40系列 120x120 12槽	659.1	659.1	109.9	109.9	11.5	1.11.40.120120.12

Strut Profile PG45
基础框架型材 45系列



45x45 R45 2 slots
45x45 R45 2槽



45x45 R90 2 slots
45x45 R90 2槽



45x45 2 slots Type A
45x45 2槽 A型



45x45 2 slots Type B
45x45 2槽 B型



45x45 3 slots
45x45 3槽



45x45 4 slots Light
45x45 4槽 轻型



45x45 4 slots
45x45 4槽



45x45 4 slots Heavy
45x45 4槽 重型



45x60 4 slots
45x60 4槽



45x90 6 slots Light
45x90 6槽 轻型



45x90 6 slots
45x90 6槽



45x90 6 slots Heavy
45x90 6槽 重型



45x135 8 slots
45x135 8槽



45x180 10 slots
45x180 10槽



90x90 8 slots
90x90 8槽



90x90 8 slots Heavy
90x90 8槽 重型



90x90 L 8 slots
90x90 L形 8槽



90x180 12 slots
90x180 12槽

Strut Profile PG45 featuring 10mm T-slot is designed for constructing heavy weight assemblies such as machine structure frame and workshop partition etc.
基础框架型材45系列, 槽宽10mm, 适用于重负载结构: 机器结构框架, 工厂车间隔段等。

Connector selection
推荐连接件



Anchor Connectorast P. 3-03
锚式连接销



Die Cast Bracket P. 3-10
压铸角铝



Angle Profile Bracket P. 3-15
挤压角铝



Inner Bracket P. 3-31
槽内直角件



Linear Bar Connector P. 3-32
槽内直线件



Screw Connector P. 3-42
大螺栓

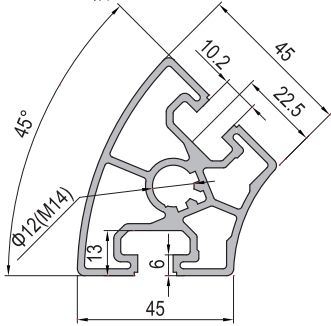
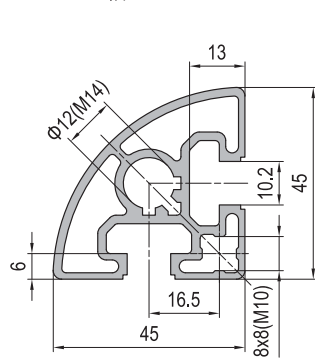
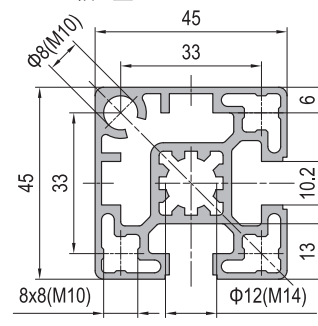
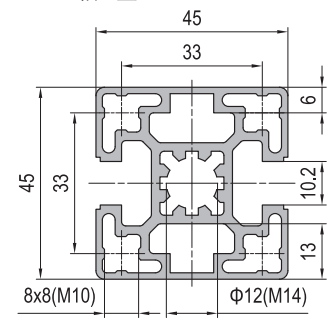
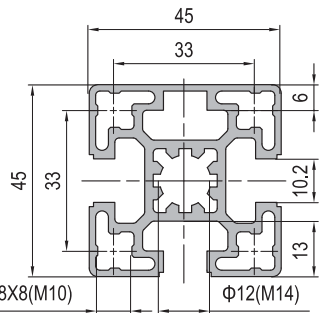
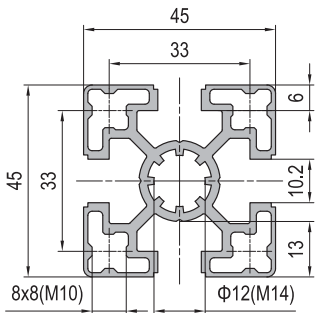
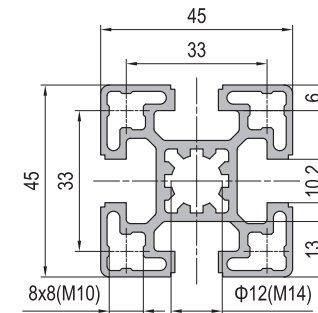
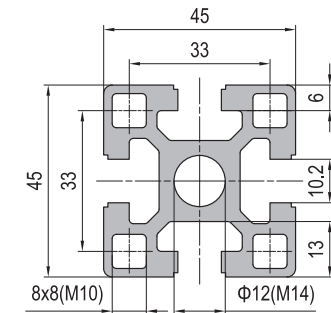

Strut Profile PG45
基础框架型材 45系列

 45x45 R45 2 slots
 45x45 R45 2槽

 45x45 R90 2 slots
 45x45 R90 2槽

 45x45 2 slots Type A
 45x45 2槽 A型

 45x45 2 slots Type B
 45x45 2槽 B型

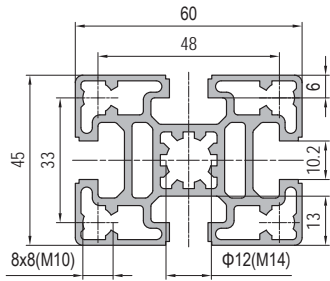
 45x45 3 slots
 45x45 3槽

 45x45 4 slots Light
 45x45 4槽 轻型

 45x45 4 slots
 45x45 4槽

 45x45 4 slots Heavy
 45x45 4槽 重型

Description 产品描述	Moment of Inertia 惯性矩 $I_x(\text{cm}^4)$	Moment of Inertia 惯性矩 $I_y(\text{cm}^4)$	Moment of Resistance 弯矩 $W_x(\text{cm}^3)$	Moment of Resistance 弯矩 $W_y(\text{cm}^3)$	Mass 重量 (kg/m)	Part No. 订购编号
Strut Profile PG45 45x45 R45 2 slots 基础框架型材 45系列 45x45 R45 2槽	20.1	15.3	7.9	5.5	2.0	1.11.45.045045.R45.02 New!
Strut Profile PG45 45x45 R90 2 slots 基础框架型材 45系列 45x45 R90 2槽	8.4	8.4	4.3	4.3	1.5	1.11.45.045045.R90.02
Strut Profile PG45 45x45 2 slots Type A 基础框架型材 45系列 45x45 2槽 A型	12.9	12.9	5.7	5.7	1.9	1.11.45.045045.02A
Strut Profile PG45 45x45 2 slots Type B 基础框架型材 45系列 45x45 2槽 B型	13.7	12.1	6.1	5.4	1.9	1.11.45.045045.02B
Strut Profile PG45 45x45 3 slots 基础框架型材 45系列 45x45 3槽	12.9	12.1	5.7	5.4	1.8	1.11.45.045045.03
Strut Profile PG45 45x45 4 slots Light 基础框架型材 45系列 45x45 4槽 轻型	10.5	10.5	4.7	4.7	1.6	1.11.45.045045.04L
Strut Profile PG45 45x45 4 slots 基础框架型材 45系列 45x45 4槽	12.1	12.1	5.4	5.4	1.8	1.11.45.045045.04
Strut Profile PG45 45x45 4 slots Heavy 基础框架型材 45系列 45x45 4槽 重型	16.5	16.5	7.4	7.4	2.4	1.11.45.045045.04H

Strut Profile PG45
基础框架型材 45系列

45x60 4 slots
45x60 4槽



45x90 6 slots Light
45x90 6槽 轻型

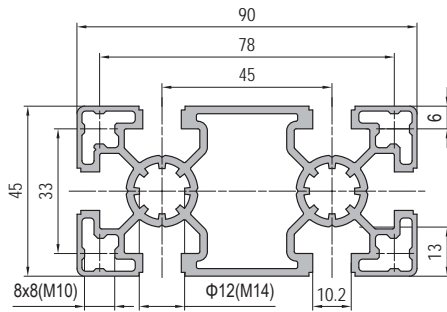

45x90 6 slots
45x90 6槽

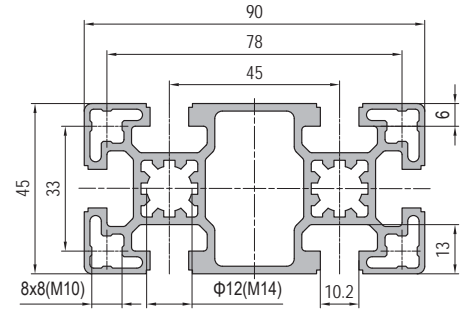

45x90 6 slots Heavy
45x90 6槽 重型

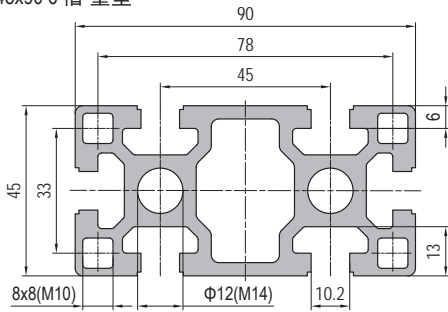

45x135 8 slots
45x135 8槽

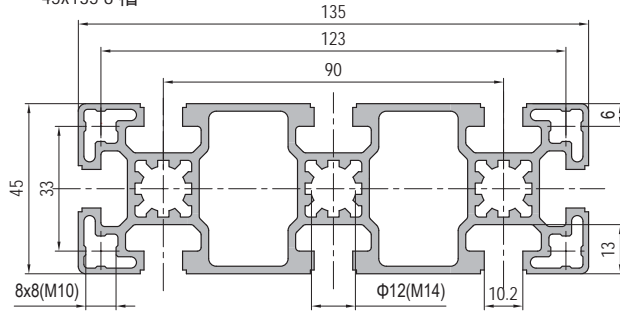

45x180 10 slots
45x180 10槽

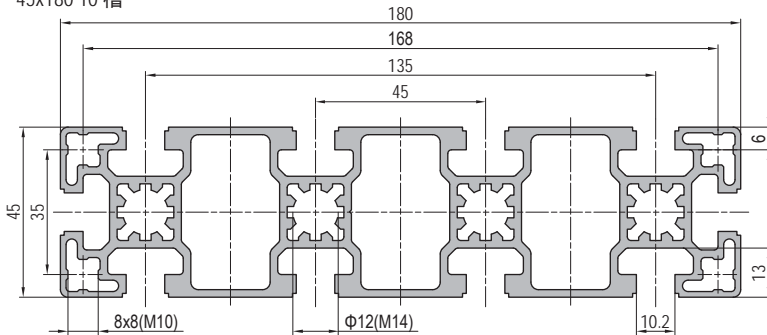

Description 产品描述	Moment of Inertia 惯性矩 $I_x(\text{cm}^4)$	Moment of Inertia 惯性矩 $I_y(\text{cm}^4)$	Moment of Resistance 弯矩 $W_x(\text{cm}^3)$	Moment of Resistance 弯矩 $W_y(\text{cm}^3)$	Mass 重量 (kg/m)	Part No. 订购编号
Strut Profile PG45 45x60 4 slots 基础框架型材 45系列 45x60 4槽	16.2	27.8	7.2	9.3	2.4	1.11.45.045060.04
Strut Profile PG45 45x90 6 slots Light 基础框架型材 45系列 45x90 6槽 轻型	21.6	80.0	9.6	17.7	2.85	1.11.45.045090.06L New!
Strut Profile PG45 45x90 6 slots 基础框架型材 45系列 45x90 6槽	24.2	89.3	10.8	19.9	3.2	1.11.45.045090.06
Strut Profile PG45 45x90 6 slots Heavy 基础框架型材 45系列 45x90 6槽 重型	32.5	122.2	14.5	27.2	4.4	1.11.45.045090.06H
Strut Profile PG45 45x135 8 slots 基础框架型材 45系列 45x135 8槽	36.3	281.8	16	41.7	4.6	1.11.45.045135.08 New!
Strut Profile PG45 45x180 10 slots 基础框架型材 45系列 45x180 10槽	48.4	640.6	21.5	71.2	5.8	1.11.45.045180.10



Strut Profile PG45
基础框架型材 45系列

90x90 8 slots
90x90 8槽

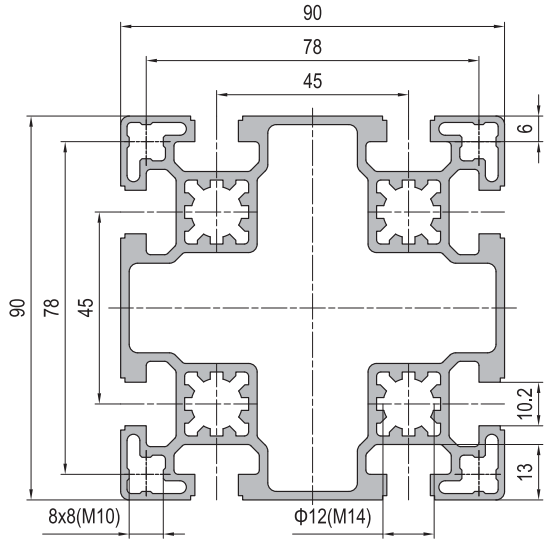

90x90 8 slots Heavy
90x90 8槽 重型

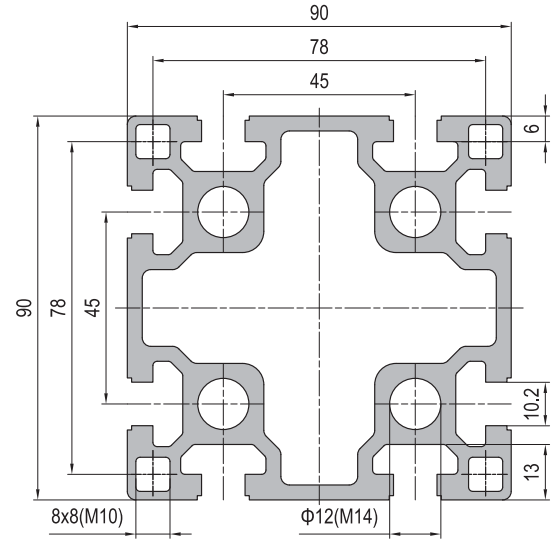

90x90 L 8 slots
90x90 L形 8槽

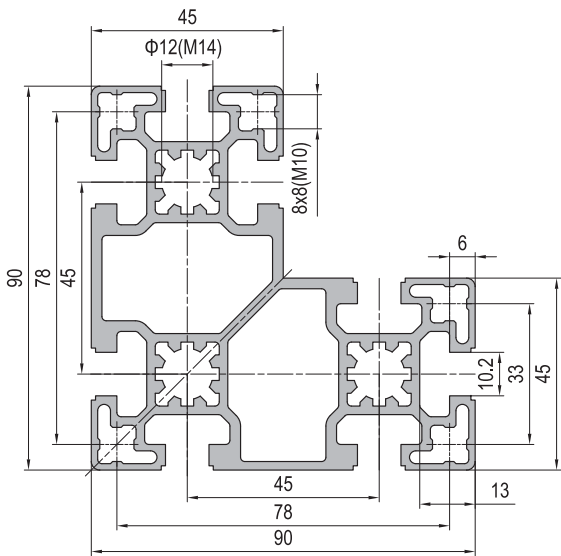

90x180 12 slots
90x180 12槽

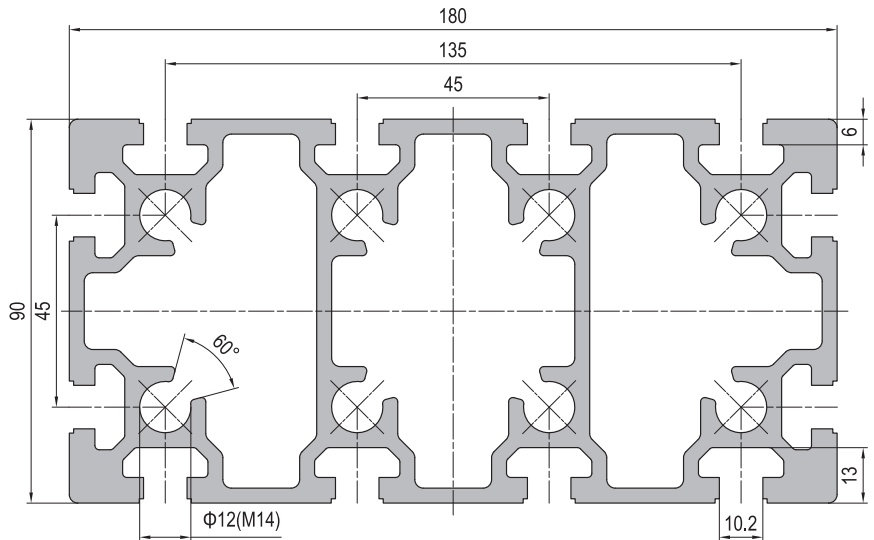

Description 产品描述	Moment of Inertia 惯性矩 Ix(cm ⁴)	Moment of Inertia 惯性矩 Iy(cm ⁴)	Moment of Resistance 弯矩 Wx(cm ³)	Moment of Resistance 弯矩 Wy(cm ³)	Mass 重量 (kg/m)	Part No. 订购编号
Strut Profile PG45 90x90 8 slots 基础框架型材 45系列 90x90 8槽	163.2	163.2	36.3	36.3	5.0	1.11.45.090090.08
Strut Profile PG45 90x90 8 slots Heavy 基础框架型材 45系列 90x90 8槽 重型	222.9	222.9	49.6	49.6	6.8	1.11.45.090090.08H
Strut Profile PG45 90x90 L 8 slots 基础框架型材 45系列 90x90 L形 8槽	121.5	121.5	32	32	4.6	1.11.45.090090L.08
Strut Profile PG45 90x180 12 slots 基础框架型材 45系列 90x180 12槽	454.9	1585.7	101.1	176.2	12.7	1.11.45.090180.12

Strut Profile PG50
基础框架型材 50系列



Strut profile PG50 featuring 10mm T-slot is designed for constructing heavy weight assemblies.
基础框架型材50系列, 槽宽10mm, 适用于重负载结构。

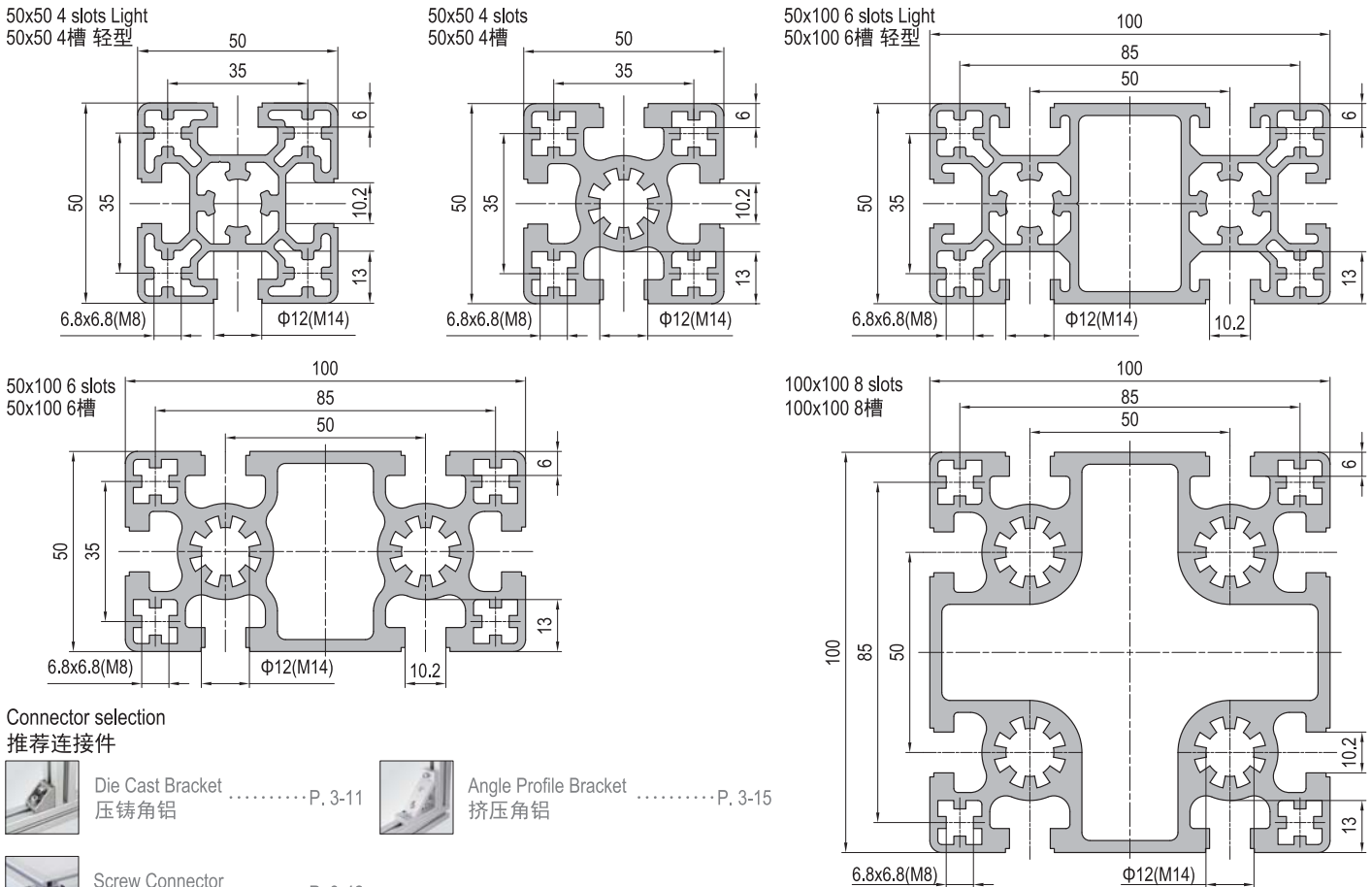

Connector selection

推荐连接件



Die Cast Bracket
压铸角铝 P. 3-11



Angle Profile Bracket
挤压角铝 P. 3-15



Screw Connector
大螺栓 P. 3-42

Description 产品描述	Moment of Inertia 惯性矩 I_x (cm^4)	Moment of Inertia 惯性矩 I_y (cm^4)	Moment of Resistance 弯矩 W_x (cm^3)	Moment of Resistance 弯矩 W_y (cm^3)	Mass 重量 (kg/m)	Part No. 订购编号
Strut Profile PG50 50x50 4 slots Light 基础框架型材 50系列 50x50 4槽 轻型	20.19	20.19	8.16	8.16	2.35	1.11.50.050050.04L
Strut Profile PG50 50x50 4 slots 基础框架型材 50系列 50x50 4槽	25.0	25.0	10.0	10.0	3.0	1.11.50.050050.04
Strut Profile PG50 50x100 6 slots Light 基础框架型材 50系列 50x100 6槽 轻型	41.3	156.7	16.5	31.3	4.2	1.11.50.050100.06L
Strut Profile PG50 50x100 6 slots 基础框架型材 50系列 50x100 6槽	46.2	184.4	18.5	36.9	5.0	1.11.50.050100.06
Strut Profile PG50 100x100 8 slots 基础框架型材 50系列 100x100 8槽	331.1	331.1	66.2	66.2	8.5	1.11.50.100100.08



Strut Profile PG60
基础框架型材 60系列



60x60 4 slots
60x60 4槽

Strut profile PG60 featuring 10mm T-slot is designed for constructing heavy weight assemblies.
基础框架型材60系列，槽宽10mm，适用于重负载结构。

60x60 4 slots
60x60 4槽

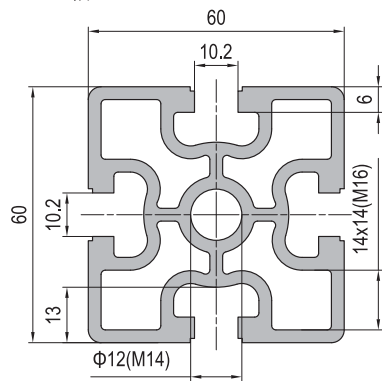

Connector selection
推荐连接件



Angle Profile Bracket P. 3-15
挤压角铝



Screw Connector P. 3-42
大螺栓

Description 产品描述	Moment of Inertia 惯性矩 $I_x(\text{cm}^4)$	Moment of Inertia 惯性矩 $I_y(\text{cm}^4)$	Moment of Resistance 弯矩 $W_x(\text{cm}^3)$	Moment of Resistance 弯矩 $W_y(\text{cm}^3)$	Mass 重量 (kg/m)	Part No. 订购编号
Strut Profile PG60 60x60 4 slots 基础框架型材 60系列 60x60 4槽	47.7	47.7	15.9	15.9	3.8	1.11.60.060060.04

Angle Profile
角铝型材

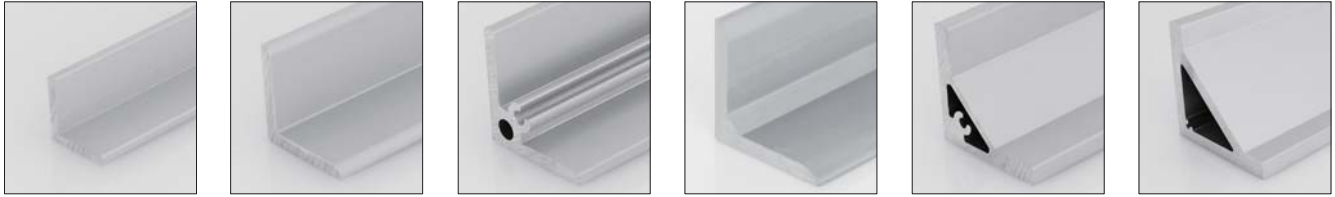

Angle Profile 20x20x3
角铝型材 20x20x3

Angle Profile 30x30x4
角铝型材 30x30x4

Angle Profile 35x35x4
角铝型材 35x35x4

Angle Profile 40x40x5
角铝型材 40x40x5

Angle Profile 50x50x9
角铝型材 50x50x9

Angle Profile 100x100x15
角铝型材 100x100x15

Angle profile is mainly used for producing angle bracket which has a wide range of applications with its good flexibility.

The surface treatment of the finished product can be natural anodized, black anodized, electrophoretic paint etc.

角铝型材主要用于制作挤压角铝连接件，由于其良好的灵活性而应用广泛，成品表面可采用多种处理方式，本色阳极氧化，黑色阳极氧化，电泳漆等。

Angle Profile 20x20x3
角铝型材 20x20x3

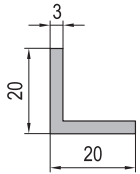

Angle Profile 30x30x4
角铝型材 30x30x4

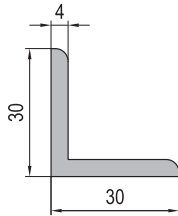

Angle Profile 35x35x4
角铝型材 35x35x4

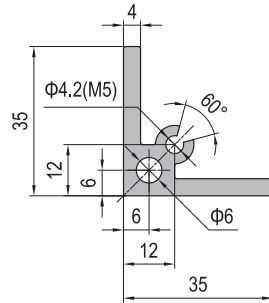

Angle Profile 40x40x5
角铝型材 40x40x5

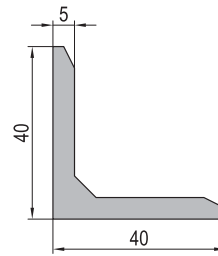

Angle Profile 50x50x9
角铝型材 50x50x9

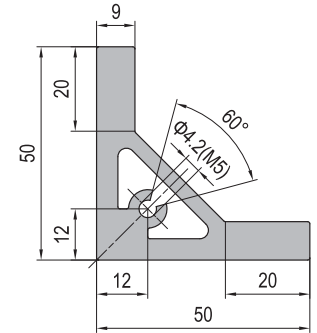

Angle Profile 100x100x15
角铝型材 100x100x15

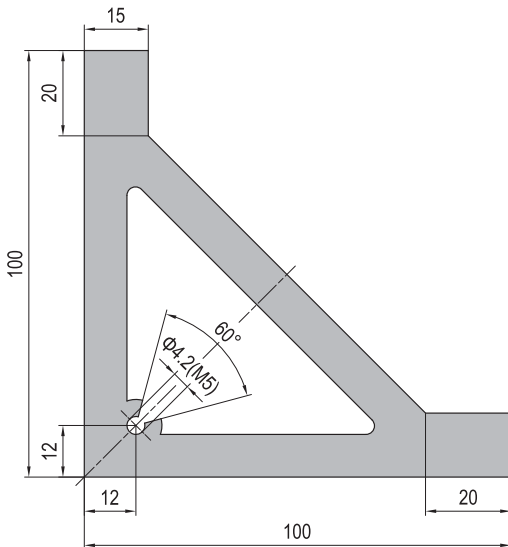

Description 产品描述	Mass 重量 (kg/m)	Part No. 订购编号
Angle Profile 20x20x3 角铝型材 20x20x3	0.3	1.31.2020.03
Angle Profile 30x30x4 角铝型材 30x30x4	0.6	1.31.3030.04
Angle Profile 35x35x4 角铝型材 35x35x4	0.9	1.31.3535.04
Angle Profile 40x40x5 角铝型材 40x40x5	1	1.31.4040.05
Angle Profile 50x50x9 角铝型材 50x50x9	2.3	1.31.5050.09
Angle Profile 100x100x15 角铝型材 100x100x15	8.5	1.31.100100.15

Note: The maximum delivery length of angle profile 100x100x15 is 4000mm, the others are all 5800mm.
备注：角铝型材100x100x15的最大供货长度为4000mm，其它角铝余均为5800mm。

Conduit Profile
 线槽型材

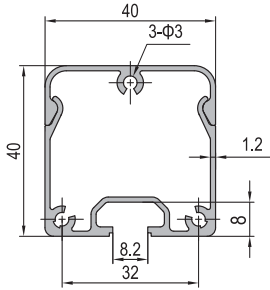
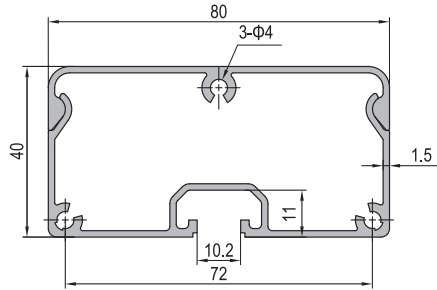
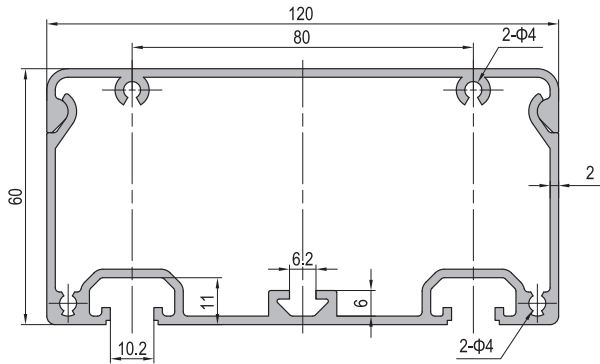
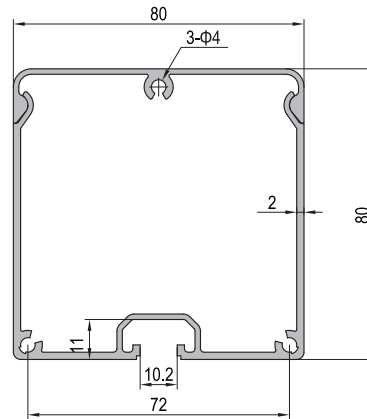
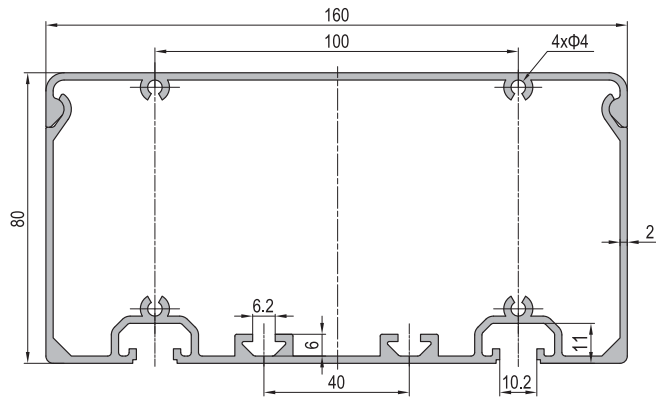
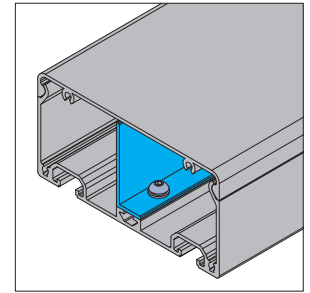
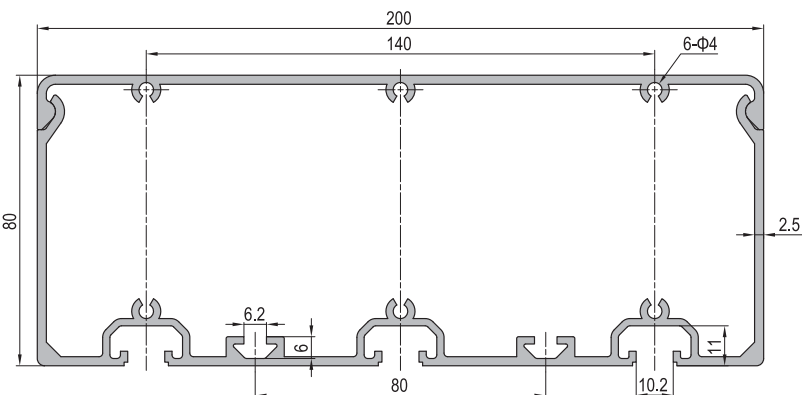
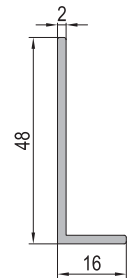
 Conduit Profile-40x40
 线槽型材-40x40

 Conduit Profile-40x80
 线槽型材-40x80

 Conduit Profile-60x120
 线槽型材-60x120

 Conduit Profile-80x80
 线槽型材-80x80

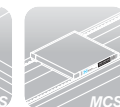
 Conduit Profile-80x160
 线槽型材-80x160

 Conduit Profile-80x200
 线槽型材-80x200

 Partition Profile-16x48
 隔板型材-16x48

Description 产品描述	Mass 重量 (kg/m)	Part No. 订购编号
Conduit Profile 40x40 线槽型材 40x40	0.82	1.41.40.040040
Conduit Profile 40x80 线槽型材 40x80	1.41	1.41.40.040080
Conduit Profile 60x120 线槽型材 60x120	2.80	1.41.40.060120
Conduit Profile 80x80 线槽型材 80x80	1.94	1.41.40.080080
Conduit Profile 80x160 线槽型材 80x160	3.64	1.41.40.080160
Conduit Profile 80x200 线槽型材 80x200	4.89	1.41.40.080200
Partition Profile 16x48 隔板型材 16x48	0.35	1.31.1648.02

Note:

- The partition profile is used for partition and arrangement of cables inside of big conduit profiles to realize the reasonable design.
隔板型材是用于大型的线槽内部的电缆的排列和区分，以实现合理的分布和设计。
- It is suggested to use the partition profile with conduit profile 60x120, 80x160 or 80x200.
建议用于线槽型材60x120、线槽型材80x160、线槽型材80x200





2.11-2.51

Pre-set Nut
预置螺母

Square Nut
方螺母

T Nut
T形螺母

Subsequent Nut
后置弹片螺母

Anti-torsion Subsequent Nut
防扭后置螺母

T Bolt
T形螺栓

Hole Reducer Bolt
变径螺栓

2

Fastening Elements 紧固件



P. 2-02



P. 2-03



P. 2-04



P. 2-05



P. 2-06



P. 2-07



P. 2-08



Fastening Elements
紧固件

Pre-set Nut
预置螺母

Pre-set Nut can be only put into T slot from profile end, with low assembly efficiency, but with good connection and stability. The sleeve is to avoid any sliding when using the pre-set nut for assembly and can be fixed at any required position, especially in vertical position.

预置螺母只能从型材端头置入T形槽内，因而装配效率不高，但具有最优良的连接强度和可靠性。预置螺母定位套与预置螺母配合使用，用于预置螺母的定位安装，特别是竖直位置放置预置螺母时，避免螺母滑落。

Material: Pre-set Nut-nickel plated steel Pre-set Nut Sleeve-EVA

材质：预置螺母-碳钢镀镍 预置螺母定位套-EVA

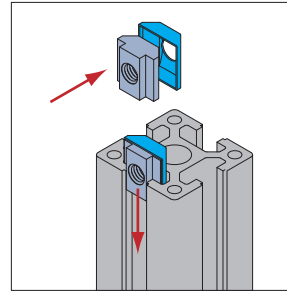
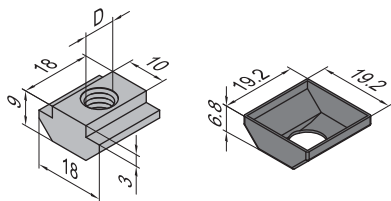
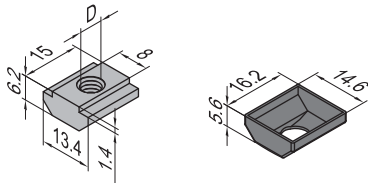
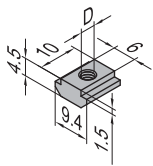

Reliability 强度:	★★★★★
Efficiency 安装效率:	★★★
Economical 经济:	★★★

Description 产品描述	D	Mass 重量 (g/pcs)	Part No. 订购编号
Pre-set Nut-6-M4 预置螺母-6-M4	M4	3	2.11.06.M4
Pre-set Nut-6-M5 预置螺母-6-M5	M5		2.11.06.M5

Description 产品描述	D	Mass 重量 (g/pcs)	Part No. 订购编号
Pre-set Nut-8-M4 预置螺母-8-M4	M4	8	2.11.08.M4
Pre-set Nut-8-M5 预置螺母-8-M5	M5	8	2.11.08.M5
Pre-set Nut-8-M6 预置螺母-8-M6	M6	7	2.11.08.M6
Pre-set Nut Sleeve-8 预置螺母定位套-8		0.3	2.11.08.01

Description 产品描述	D	Mass 重量 (g/pcs)	Part No. 订购编号
Pre-set Nut-10-M4 预置螺母-10-M4	M4	16	2.11.10.M4
Pre-set Nut-10-M5 预置螺母-10-M5	M5	16	2.11.10.M5
Pre-set Nut-10-M6 预置螺母-10-M6	M6	15	2.11.10.M6
Pre-set Nut-10-M8 预置螺母-10-M8	M8	14	2.11.10.M8
Pre-set Nut Sleeve-10 预置螺母定位套-10		0.4	2.11.10.01



Fastening Elements
紧固件

Square Nut
方螺母

The clip is to avoid any sliding when using the square nut for assembly and can be fixed at any required position, especially at vertical position.

方螺母只能从型材端头置入T形槽内，因而装配效率不高，但价格较低。方螺母弹片与方螺母配合使用，用于方螺母的定位安装，特别是竖直位置放置方螺母时，避免螺母滑落。

Material: zinc plated steel
材质：碳钢镀锌

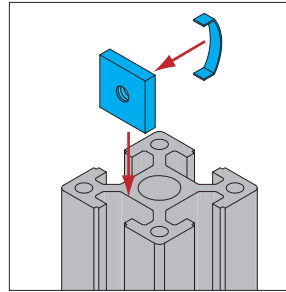

Reliability 强度:	★★★★
Efficiency 安装效率:	★★★
Economical 经济:	★★★★★

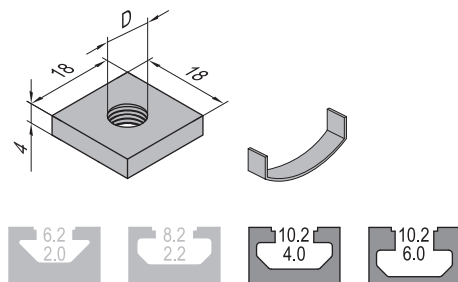
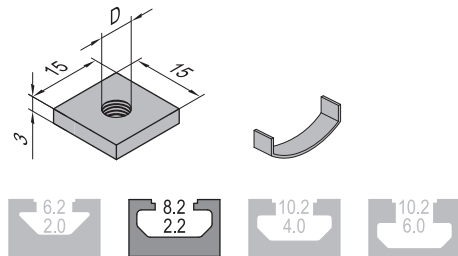

Description 产品描述	D	Mass 重量 (g/pcs)	Part No. 订购编号
Square Nut-8-M4 方螺母-8-M4	M4	5	2.12.08.M4
Square Nut-8-M5 方螺母-8-M5	M5		2.12.08.M5
Square Nut-8-M6 方螺母-8-M6	M6		2.12.08.M6
Square Nut Clip-8 方螺母弹片-8		0.4	2.12.08.01

Description 产品描述	D	Mass 重量 (g/pcs)	Part No. 订购编号
Square Nut-10-M4 方螺母-10-M4	M4	10	2.12.10.M4
Square Nut-10-M5 方螺母-10-M5	M5	10	2.12.10.M5
Square Nut-10-M6 方螺母-10-M6	M6	9	2.12.10.M6
Square Nut-10-M8 方螺母-10-M8	M8	8	2.12.10.M8
Square Nut Clip-10 方螺母弹片-10		0.5	2.12.10.01



Fastening Elements
紧固件

T Nut
T形螺母

T Nut can be inserted directly at the assembly point, which makes the assembly very efficient, however the connection strength and stability is not as good as pre-set nut.
T形螺母可以从T形槽外部直接置入槽内，因而装配效率高，但连接强度和可靠性均不及预置螺母。

Material: nickel plated steel
材质：碳钢镀镍

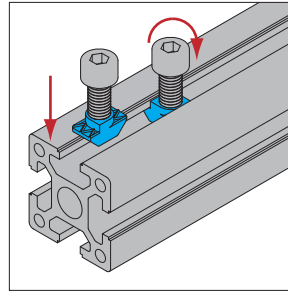

Reliability 强度:	★★★★
Efficiency 安装效率:	★★★★★
Economical 经济:	★★★★

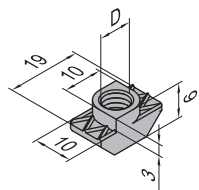
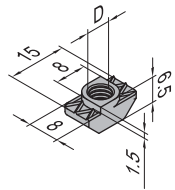
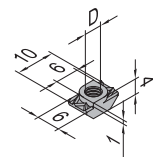

Description 产品描述	D	Mass 重量 (g/pcs)	Part No. 订购编号
T Nut-6-M4 T形螺母-6-M4	M4	2	2.21.06.M4
T Nut-6-M5 T形螺母-6-M5	M5		2.21.06.M5

Description 产品描述	D	Mass 重量 (g/pcs)	Part No. 订购编号
T Nut-8-M4 T形螺母-8-M4	M4	4	2.21.08.M4
T Nut-8-M5 T形螺母-8-M5	M5	4	2.21.08.M5
T Nut-8-M6 T形螺母-8-M6	M6	3	2.21.08.M6

Description 产品描述	D	Mass 重量 (g/pcs)	Part No. 订购编号
T Nut-10-M4 T形螺母-10-M4	M4	8	2.21.10.M4
T Nut-10-M5 T形螺母-10-M5	M5	8	2.21.10.M5
T Nut-10-M6 T形螺母-10-M6	M6	7	2.21.10.M6
T Nut-10-M8 T形螺母-10-M8	M8	6	2.21.10.M8



Fastening Elements
紧固件

Subsequent Nut
后置弹片螺母

Subsequent Nut with a spring leaf can be inserted directly at the assembly point. The spring assists with assembly and positioning. The connecting strength and stability is same as t nut.

后置弹片螺母不仅可以从型材T形槽外部直接置入槽内，还能依靠弹片的弹力保持其在槽内位置，连接强度和可靠性与T形螺母相当。

Material: zinc plated steel

材质：碳钢镀锌



Reliability 强度:	★★★★
Efficiency 安装效率:	★★★★
Economical 经济:	★★★

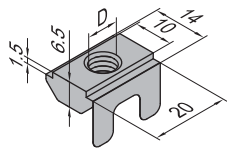
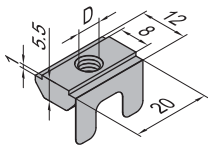
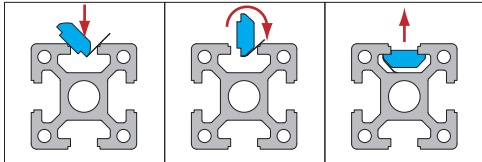

Description 产品描述	D	Mass 重量 (g/pcs)	Part No. 订购编号
Subsequent Nut -8-M4 后置弹片螺母-8-M4	M4	8	2.31.08.M4
Subsequent Nut -8-M5 后置弹片螺母-8-M5	M5		2.31.08.M5
Subsequent Nut -8-M6 后置弹片螺母-8-M6	M6	7	2.31.08.M6
Subsequent Nut -8-M8 后置弹片螺母-8-M8	M8		2.31.08.M8

Description 产品描述	D	Mass 重量 (g/pcs)	Part No. 订购编号
Subsequent Nut -10-M4 后置弹片螺母-10-M4	M4	10	2.31.10.M4
Subsequent Nut -10-M5 后置弹片螺母-10-M5	M5		2.31.10.M5
Subsequent Nut -10-M6 后置弹片螺母-10-M6	M6	9	2.31.10.M6
Subsequent Nut -10-M8 后置弹片螺母-10-M8	M8		2.31.10.M8



Fastening Elements
紧固件

Anti-torsion Subsequent Nut
防扭后置螺母

Prevent profiles with screw connectors from torsion.
防扭后置螺母用于防止型材之间用螺栓连接时的扭转。

Material: nickel plated steel
材质: 碳钢镀镍

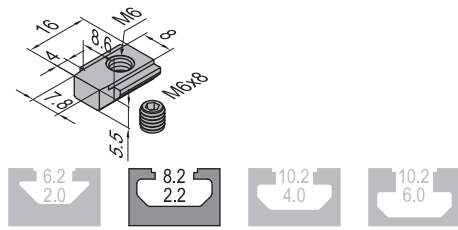
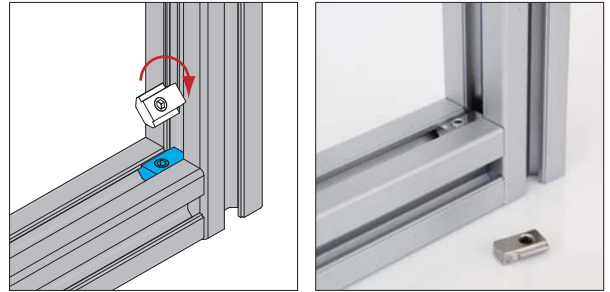

Description 产品描述	Mass 重量 (g/pcs)	Part No. 订购编号
Anti-torsion Subsequent Nut-8 (with top thread) 8槽防扭后置螺母 (含顶丝)	10	2.32.08.M6

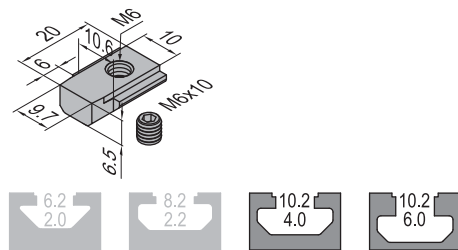

Description 产品描述	Mass 重量 (g/pcs)	Part No. 订购编号
Anti-torsion Subsequent Nut-10 (with top thread) 10槽防扭后置螺母 (含顶丝)	15	2.32.10.M6

Fastening Elements
紧固件

T Bolt
T形螺栓

Similar to T nut, T bolt can be inserted directly at assembly point, with high assembly efficiency. The connection strength and stability are same as T nut.

与T形螺母相似，T形螺栓可以从T形槽外部直接置入槽内，因而装配效率高，其连接强度和可靠性也与T形螺母相当。

Material: nickel plated steel

材质：碳钢镀镍

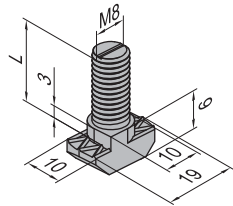
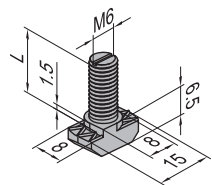
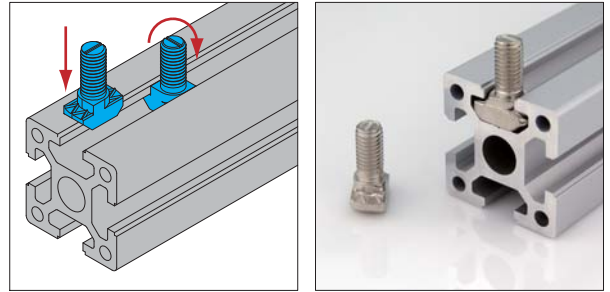

Description 产品描述	L (mm)	Mass 重量 (g/pcs)	Part No. 订购编号
T Bolt-8-16 T形螺栓-8-16	16	7	2.41.08.16
T Bolt-8-20 T形螺栓-8-20	20	8	2.41.08.20
T Bolt-8-25 T形螺栓-8-25	25	9	2.41.08.25

Description 产品描述	L (mm)	Mass 重量 (g/pcs)	Part No. 订购编号
T Bolt-10-20 T形螺栓-10-20	20	13	2.41.10.20
T Bolt-10-25 T形螺栓-10-25	25	15	2.41.10.25
T Bolt-10-30 T形螺栓-10-30	30	17	2.41.10.30
T Bolt-10-35 T形螺栓-10-35	35	19	2.41.10.35 New!



Fastening Elements
紧固件

Hole Reducer Bolt
变径螺栓



To reduce the hole diameter of the profile and improve the thread connection strength.

变径螺栓用于减小型材孔径和提高螺纹连接强度。

Material: nickel plated steel

材质: 碳钢镀镍

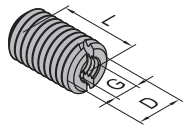

Description 产品描述	D	G	L (mm)	Mass 重量 (g/pcs)	Part No. 订购编号
Hole Reducer Bolt-M10/M6 变径螺栓-M10/M6	M10	M6	15	8	2.51.10.06
Hole Reducer Bolt-M12/M6 变径螺栓-M12/M6	M12	M6	20	11	2.51.12.06
Hole Reducer Bolt-M14/M8 变径螺栓-M14/M8	M14	M8	20	14	2.51.14.08
Hole Reducer Bolt-M14/M10 变径螺栓-M14/M10	M14	M10	20	8	2.51.14.10
Hole Reducer Bolt-M16/M8 变径螺栓-M16/M8	M16	M8	20	19	2.51.16.08



Hole Reducer Bolt M10/M6
PG45 with square corner hole-8x8(M10)
用于45系列型材四角孔-8x8(M10)



Hole Reducer Bolt M12/M6
PG30 with core hole- Φ 10(M12)
用于30系列型材中心孔- Φ 10(M12)



Hole Reducer Bolt M14/M8
PG40/PG45/PG50/PG60 with core hole- Φ 12(M14)
用于40系列/45系列/50系列/60系列型材中心孔- Φ 12(M14)



Hole Reducer Bolt M16/M8
PG60 with square corner hole-14x14(M16)
用于60系列型材四角孔-14x14(M16)



3.11-3.92

Anchor Connector
锚式连接销

Die Cast Bracket
压铸角铝

Angle Profile Bracket
挤压角铝

Inner Bracket
槽内直角件

Linear Bar Connector
槽内直线件

Joining Plate
连接板

Butt Connector
内置连接件

End Connector
端连接件

Screw Connector
大螺栓

Cubic Connector
三维连接件

3

Connecting Elements 连接件



P. 3-03



P. 3-07



P. 3-12



P. 3-31

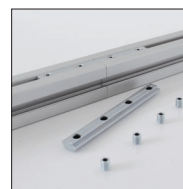

P. 3-32



P. 3-34



P. 3-40

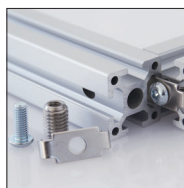

P. 3-41

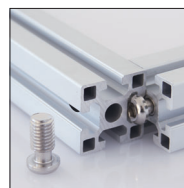

















P. 3-42

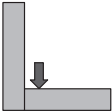
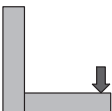
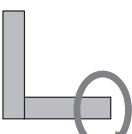

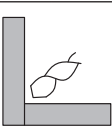
P. 3-43

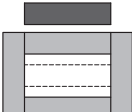
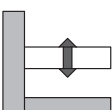
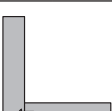
Selection Reference
选型参考

	 Recommended 推荐	 Suitable 适用	 Unsuitable 不适用	 Anchor Connector 锚式连接销	 Die Cast Bracket 压铸角铝	 Angle Profile Bracket 挤压角铝	 Inner Bracket 槽内直角件	 Butt Connector 内置连接件	 End Connector 端连接件	 Screw Connector 大螺栓
 High feed force 高压力										
 High moment 高力矩										
 High torsional moment 高扭矩										 
 Minimal finishing work 加工										
 Minimal assembly 安装效率										
 Low parts costs 低成本										
 Subsequent mounting in closed frame 可后续安装在封闭结构上										
 Adjustment possible 可调节										
 Internal connection (concealable) 内部连接 (可隐藏)										
 Angle connection 角度连接										

Connecting Elements
连接件

Anchor Connector
锚式连接销

Material: zinc plated steel
材质: 碳钢镀锌



Universal
万向型

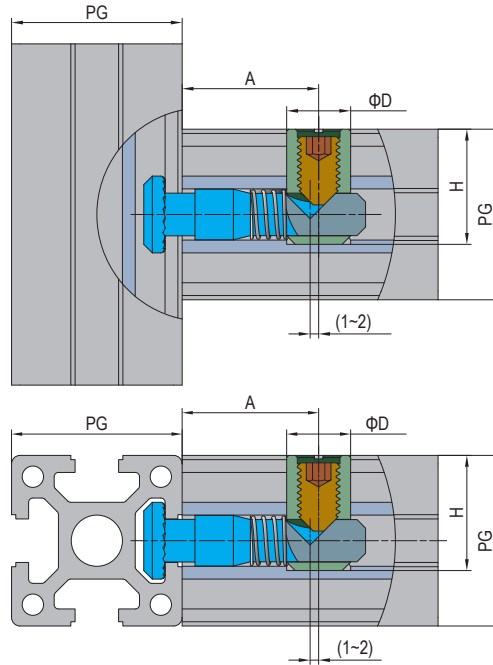
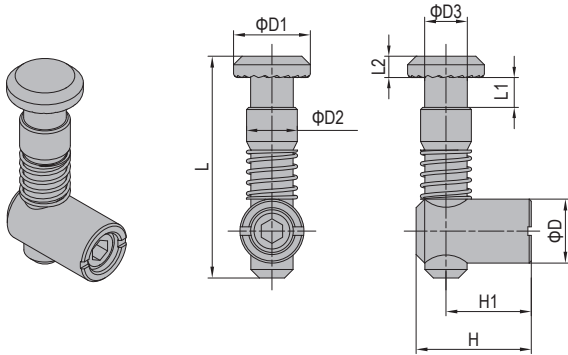

Description 产品描述	A	D	H	H1	L1	L2	D1	D2	D3	L	Mass 重量(g/unit)	Part No. 订购编号
PG30-Universal 30系列-万向型	30	12	21	15	7	4	14	9.9	8	45	38	3.11.30.01
PG40-Universal 40系列-万向型	32	15	27	20	7	5	18	11.9	10	52	58	3.11.40.01
PG45-Universal 45系列-万向型	30	15	29.5	22.5	7	5	18	11.9	10	52	60	3.11.45.01

Connecting Elements
连接件

Anchor Connector
锚式连接销

Material: zinc plated steel
材质: 碳钢镀锌



Standard (Model P)
标准型 (P)

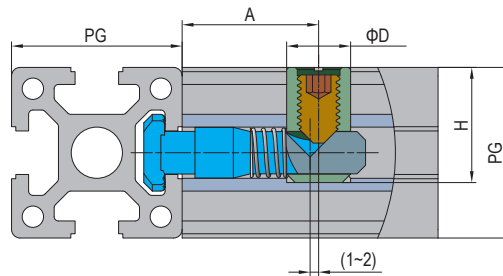
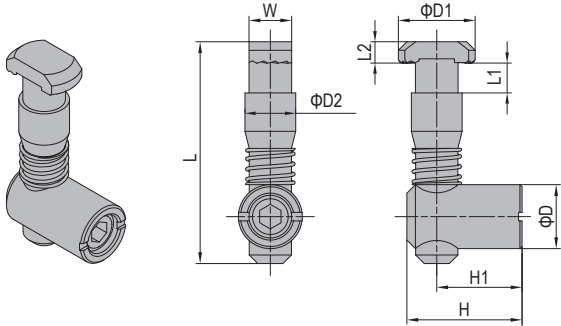

Description 产品描述	A	D	H	H1	L1	L2	D1	D2	W	L	Mass 重量(g/unit)	Part No. 订购编号
PG30-Standard (Model P) 30系列-标准型 (P)	30	12	21	15	7	4	14	9.9	8	45	38	3.11.30.02
PG40-Standard (Model P) 40系列-标准型 (P)	32	15	27	20	7	5	18	11.9	10	52	58	3.11.40.02
PG45-Standard (Model P) 45系列-标准型 (P)	30	15	29.5	22.5	7	5	18	11.9	10	52	60	3.11.45.02

Standard (Model C)
标准型 (C)

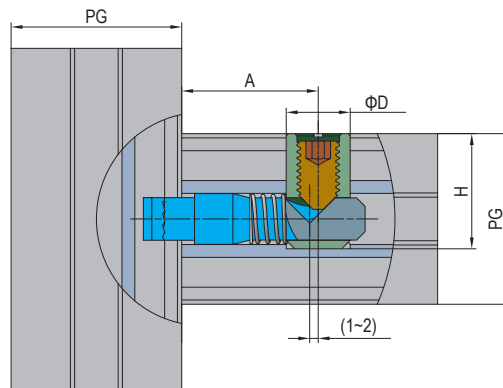
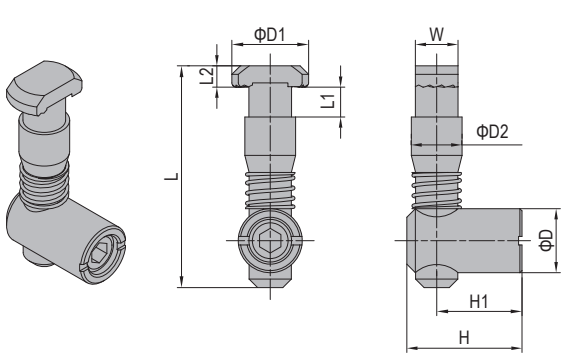

Description 产品描述	A	D	H	H1	L1	L2	D1	D2	W	L	Mass 重量(g/unit)	Part No. 订购编号
PG30-Standard (Model C) 30系列-标准型 (C)	30	12	21	15	7	4	14	9.9	8	45	38	3.11.30.03
PG40-Standard (Model C) 40系列-标准型 (C)	32	15	27	20	7	5	18	11.9	10	52	58	3.11.40.03
PG45-Standard (Model C) 45系列-标准型 (C)	30	15	29.5	22.5	7	5	18	11.9	10	52	60	3.11.45.03



Connecting Elements
连接件

Anchor Connector
锚式连接销

Material: zinc plated steel
材质: 碳钢镀锌

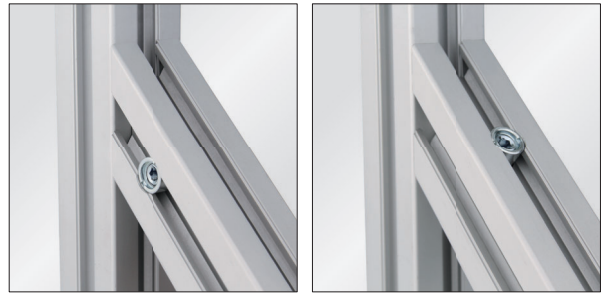
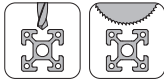

Oblique (Model P)
转角型 (P)

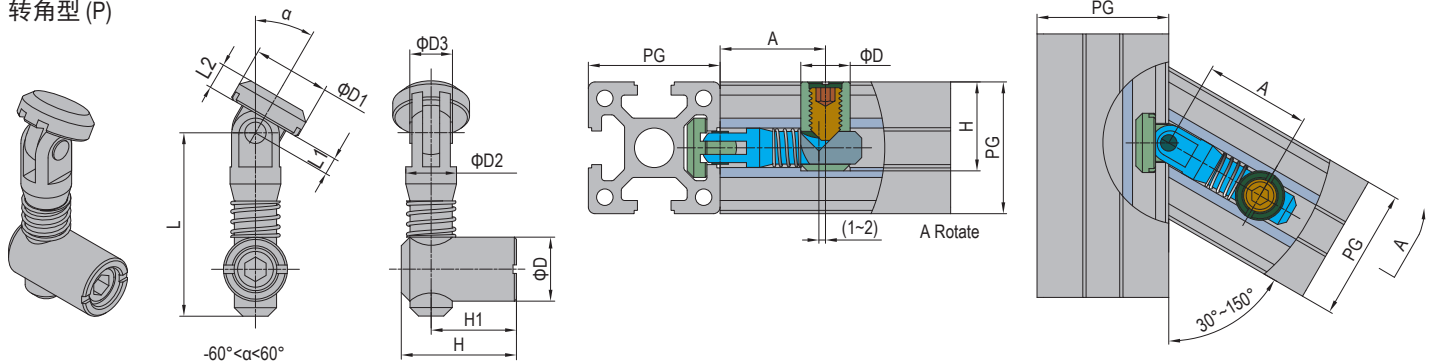

Description 产品描述	A	D	H	H1	L1	L2	D1	D2	D3	L	Mass 重量(g/unit)	Part No. 订购编号
PG30-Oblique (Model P) 30系列-转角型 (P)	30	12	21	15	2.2	5	14	9.9	8	38.8	55	3.11.30.04
PG40-Oblique (Model P) 40系列-转角型 (P)	32	15	27	20	4	6	18	11.9	10	43	72	3.11.40.04
PG45-Oblique (Model P) 45系列-转角型 (P)	32	15	29.5	22.5	6	5	18	11.9	10	43	78	3.11.45.04

Oblique (Model C)
转角型 (C)

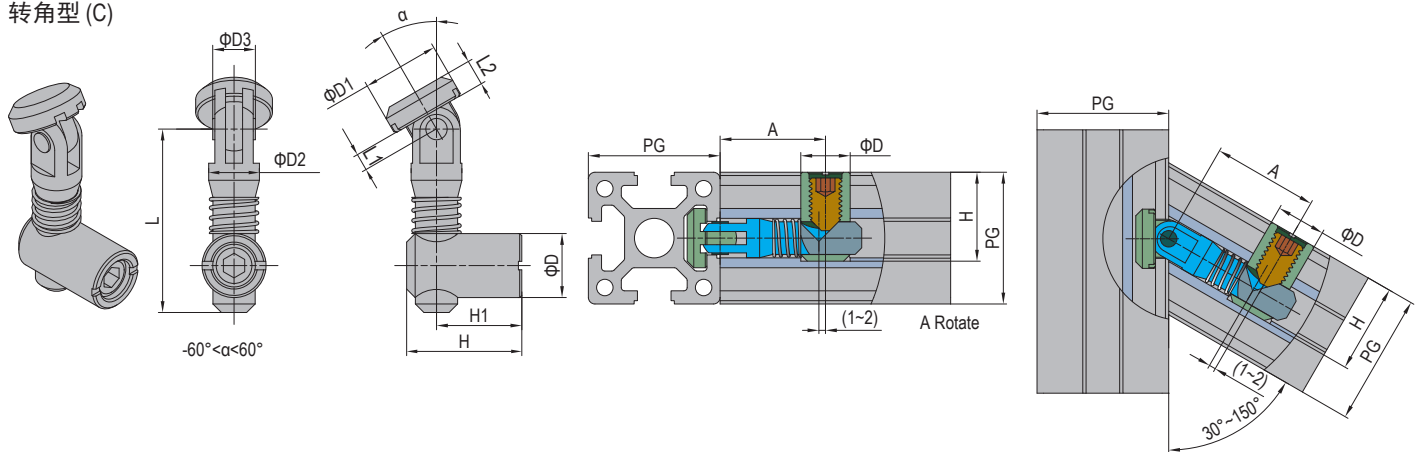

Description 产品描述	A	D	H	H1	L1	L2	D1	D2	D3	L	Mass 重量(g/unit)	Part No. 订购编号
PG30-Oblique (Model C) 30系列-转角型 (C)	30	12	21	15	2.2	5	14	9.9	8	38.8	55	3.11.30.05
PG40-Oblique (Model C) 40系列-转角型 (C)	32	15	27	20	4	6	18	11.9	10	43	72	3.11.40.05
PG45-Oblique (Model C) 45系列-转角型 (C)	32	15	29.5	22.5	6	5	18	11.9	10	43	78	3.11.45.05



Connecting Elements
连接件

Anchor Connector
锚式连接销

Material: zinc plated steel
材质: 碳钢镀锌

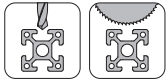

Miter (Model P)
对接型 (P)

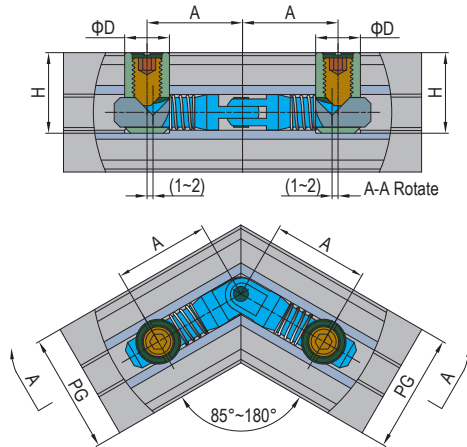
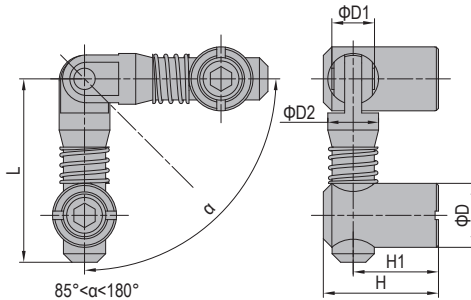
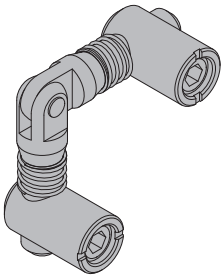

Description 产品描述	A	D	H	H1	D1	D2	L	Mass 重量(g/unit)	Part No. 订购编号
PG30-Miter (Model P) 30系列-对接型 (P)	30	12	21	15	8	9.9	38.8	63	3.11.30.06
PG40-Miter (Model P) 40系列-对接型 (P)	32	15	27	20	10	11.9	43	97	3.11.40.06
PG45-Miter (Model P) 45系列-对接型 (P)	32	15	29.5	22.5	10	11.9	43	100	3.11.45.06

Miter (Model C)
对接型 (C)

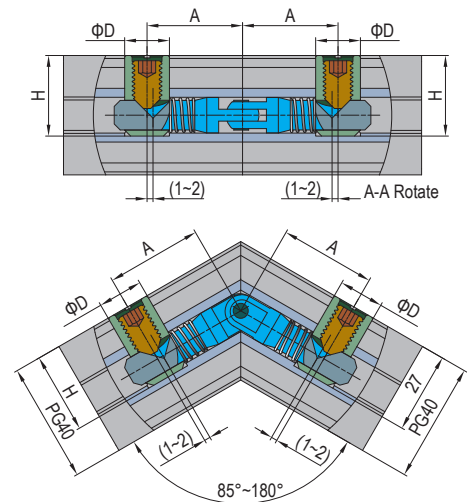
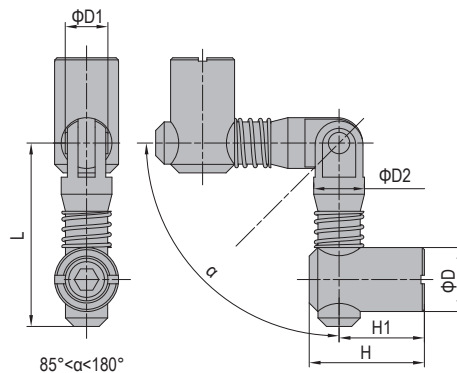
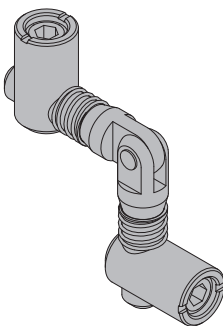

Description 产品描述	A	D	H	H1	D1	D2	L	Mass 重量(g/unit)	Part No. 订购编号
PG30-Miter (Model C) 30系列-对接型 (C)	30	12	21	15	8	9.9	38.8	63	3.11.30.07
PG40-Miter (Model C) 40系列-对接型 (C)	32	15	27	20	10	11.9	43	97	3.11.40.07
PG45-Miter (Model C) 45系列-对接型 (C)	32	15	29.5	22.5	10	11.9	43	100	3.11.45.07

Connecting Elements
连接件

Die Cast Bracket
压铸角铝
Material: diecast aluminum
材质: 压铸铝合金



PG20-20x20
20系列-20x20

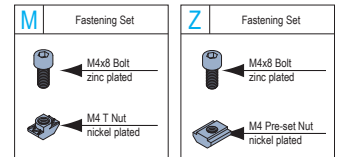
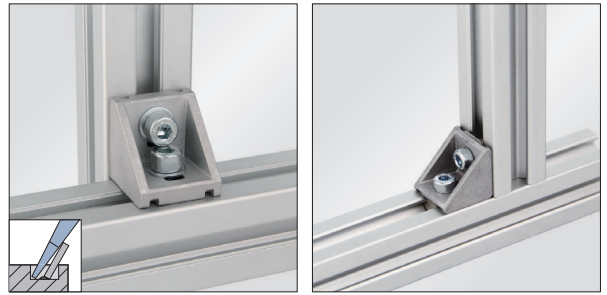
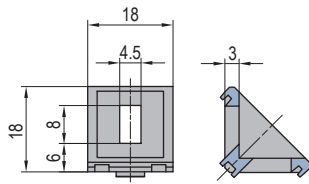

Description 产品描述	Fastening Set 紧固组件	Mass 重量 (g)	Part No. 订购编号
PG20-20x20 (pcs) 20系列-20x20 (单个供货)		5	3.21.20.2020
PG20-20x20 (set M) 20系列-20x20 (成套供货M)	2xM	12	3.21.20.2020.STM
PG20-20x20 (set Z) 20系列-20x20 (成套供货Z)	2xZ		3.21.20.2020.STZ



Connecting Elements
连接件

Die Cast Bracket
压铸角铝
Material: diecast aluminum
材质: 压铸铝合金



PG30-30x30
30系列-30x30

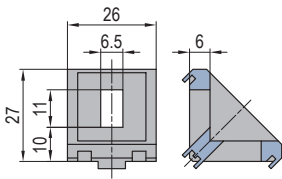

PG30-30x60
30系列-30x60

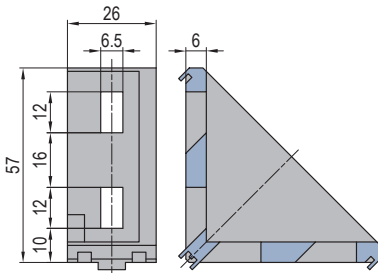

PG30-60x60
30系列-60x60

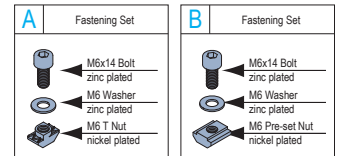
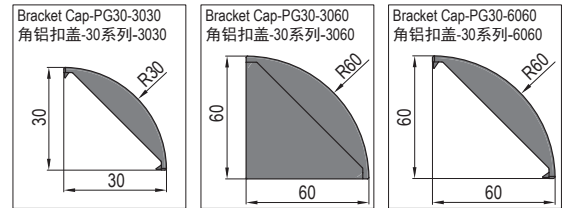
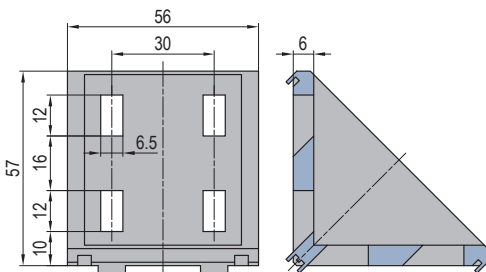

Description 产品描述	Fastening Set 紧固组件	Mass 重量 (g)	Part No. 订购编号
PG30-30x30 (pcs) 30系列-30x30 (单个供货)		21	3.21.30.3030
PG30-30x30 (set A) 30系列-30x30 (成套供货A)	2xA	42	3.21.30.3030.STA
PG30-30x30 (set B) 30系列-30x30 (成套供货B)	2xB	48	3.21.30.3030.STB
Bracket Cap-PG30-3030 角铝扣盖-30系列-3030		3	3.22.30.3030
PG30-30x60 (pcs) 30系列-30x60 (单个供货)		53	3.21.30.3060
PG30-30x60 (set A) 30系列-30x60 (成套供货A)	4xA	93	3.21.30.3060.STA
PG30-30x60 (set B) 30系列-30x60 (成套供货B)	4xB	105	3.21.30.3060.STB
Bracket Cap-PG30-3060 角铝扣盖-30系列-3060		12.4	3.22.30.3060
PG30-60x60 (pcs) 30系列-60x60 (单个供货)		120	3.21.30.6060
PG30-60x60 (set A) 30系列-60x60 (成套供货A)	8xA	200	3.21.30.6060.STA
PG30-60x60 (set B) 30系列-60x60 (成套供货B)	8xB	224	3.21.30.6060.STB
Bracket Cap-PG30-6060 角铝扣盖-30系列-6060		13.9	3.22.30.6060

Connecting Elements
连接件

Die Cast Bracket
压铸角铝
Material: diecast aluminum
材质: 压铸铝合金



PG40-40x40
40系列-40x40

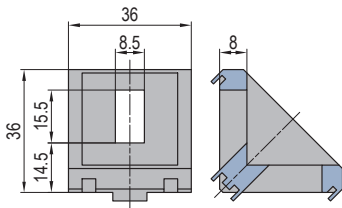

PG40-40x80
40系列-40x80

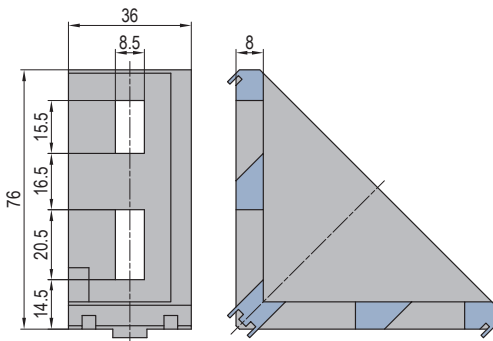

PG40-80x80
40系列-80x80

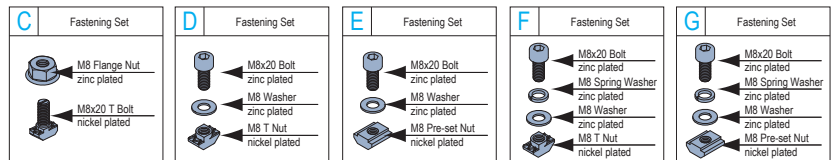
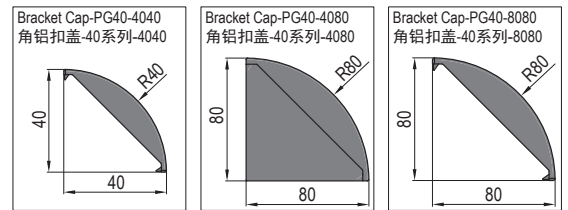
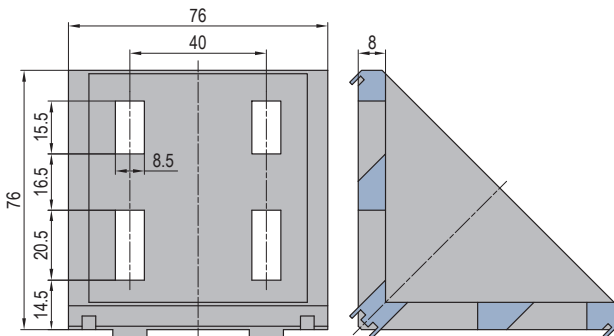

Description 产品描述	Fastening Set 紧固组件	Mass 重量 (g)	Part No. 订购编号
PG40-40x40 (pcs) 40系列-40x40 (单个供货)		50	3.21.40.4040
PG40-40x40 (set C) 40系列-40x40 (成套供货C)	2xC	92	3.21.40.4040.STC
PG40-40x40 (set D) 40系列-40x40 (成套供货D)	2xD	92	3.21.40.4040.STD
PG40-40x40 (set E) 40系列-40x40 (成套供货E)	2xE	106	3.21.40.4040.STE
Bracket Cap-PG40-4040 角铝扣盖-40系列-4040		6	3.22.40.4040
PG40-40x80 (pcs) 40系列-40x80 (单个供货)		125	3.21.40.4080
PG40-40x80 (set C) 40系列-40x80 (成套供货C)	4xC	210	3.21.40.4080.STC
PG40-40x80 (set F) 40系列-40x80 (成套供货F)	4xF	220	3.21.40.4080.STF
PG40-40x80 (set G) 40系列-40x80 (成套供货G)	4xG	250	3.21.40.4080.STG
Bracket Cap-PG40-4080 角铝扣盖-40系列-4080		22.6	3.22.40.4080
PG40-80x80 (pcs) 40系列-80x80 (单个供货)		260	3.21.40.8080
PG40-80x80 (set C) 40系列-80x80 (成套供货C)	8xC	428	3.21.40.8080.STC
PG40-80x80 (set F) 40系列-80x80 (成套供货F)	8xF	452	3.21.40.8080.STF
PG40-80x80 (set G) 40系列-80x80 (成套供货G)	8xG	508	3.21.40.8080.STG
Bracket Cap-PG40-8080 角铝扣盖-40系列-8080		25.6	3.22.40.8080



Connecting Elements
连接件

Die Cast Bracket
压铸角铝
Material: diecast aluminum
材质: 压铸铝合金



PG45-45x45
45系列-45x45

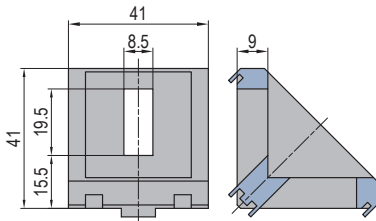

PG45-45x90
45系列-45x90

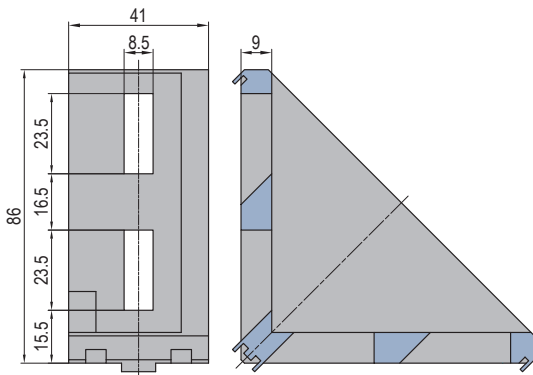

PG45-90x90
45系列-90x90

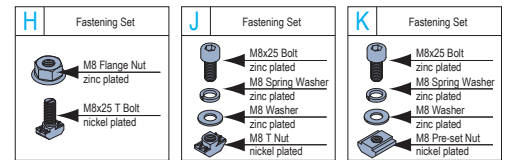
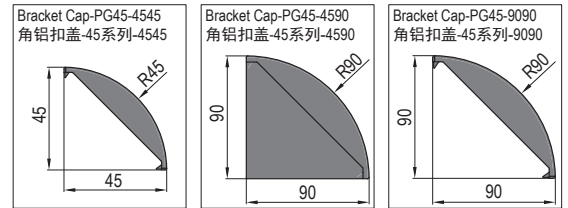
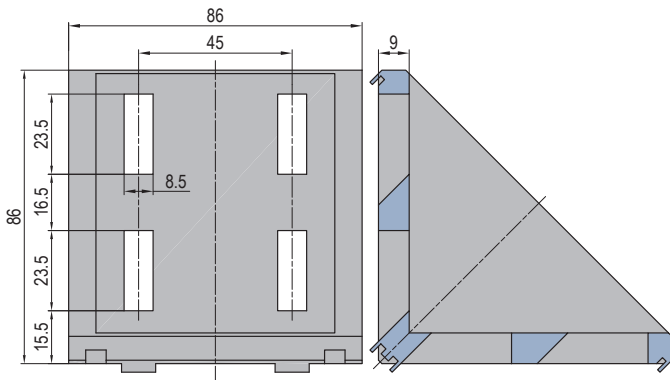

Description 产品描述	Fastening Set 紧固组件	Mass 重量 (g)	Part No. 订购编号
PG45-45x45 (pcs) 45系列-45x45 (单个供货)		72	3.21.45.4545
PG45-45x45 (set H) 45系列-45x45 (成套供货H)	2xH	118	3.21.45.4545.STH
PG45-45x45 (set J) 45系列-45x45 (成套供货J)	2xJ	122	3.21.45.4545.STJ
PG45-45x45 (set K) 45系列-45x45 (成套供货K)	2xK	134	3.21.45.4545.STK
Bracket Cap-PG45-4545 角铝扣盖-45系列-4545		7.6	3.22.45.4545
PG45-45x90 (pcs) 45系列-45x90 (单个供货)		190	3.21.45.4590
PG45-45x90 (set H) 45系列-45x90 (成套供货H)	4xH	282	3.21.45.4590.STH
PG45-45x90 (set J) 45系列-45x90 (成套供货J)	4xJ	290	3.21.45.4590.STJ
PG45-45x90 (set K) 45系列-45x90 (成套供货K)	4xK	314	3.21.45.4590.STK
Bracket Cap-PG45-4590 角铝扣盖-45系列-4590		28.7	3.22.45.4590
PG45-90x90 (pcs) 45系列-90x90 (单个供货)		390	3.21.45.9090
PG45-90x90 (set H) 45系列-90x90 (成套供货H)	8xH	574	3.21.45.9090.STH
PG45-90x90 (set J) 45系列-90x90 (成套供货J)	8xJ	590	3.21.45.9090.STJ
PG45-90x90 (set K) 45系列-90x90 (成套供货K)	8xK	638	3.21.45.9090.STK
Bracket Cap-PG45-9090 角铝扣盖-45系列-9090		32.5	3.22.45.9090



Connecting Elements
连接件

Die Cast Bracket
压铸角铝
Material: diecast aluminum
材质: 压铸铝合金



PG50-50x50
50系列-50x50

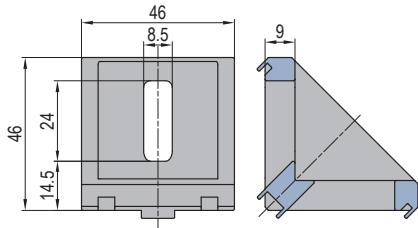

PG50-50x100
50系列-50x100

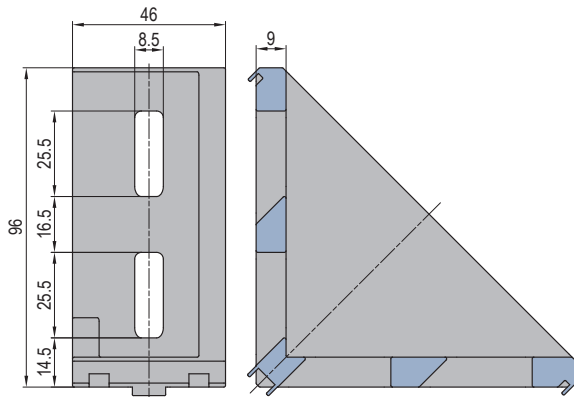

PG50-100x100
50系列-100x100

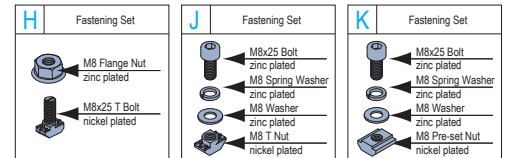
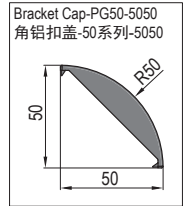
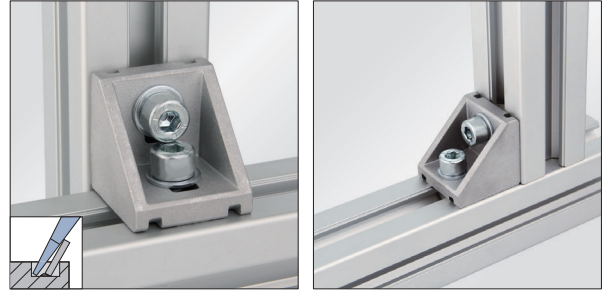
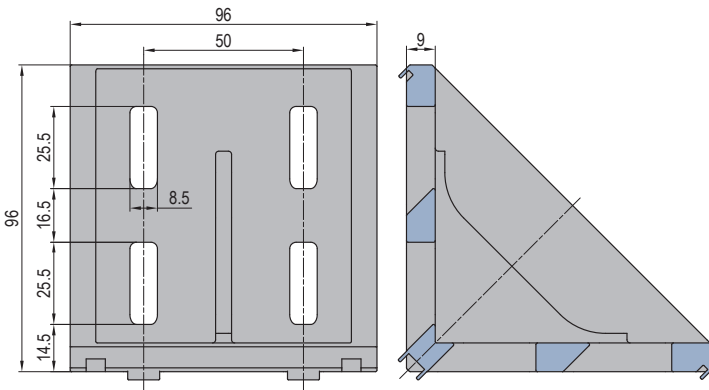

Description 产品描述	Fastening Set 紧固组件	Mass 重量 (g)	Part No. 订购编号
PG50-50x50 (pcs) 50系列-50x50 (单个供货)		86	3.21.50.5050
PG50-50x50 (set H) 50系列-50x50 (成套供货H)	2xH	132	3.21.50.5050.STH
PG50-50x50 (set J) 50系列-50x50 (成套供货J)	2xJ	135	3.21.50.5050.STJ
PG50-50x50 (set K) 50系列-50x50 (成套供货K)	2xK	152	3.21.50.5050.STK
Bracket Cap-PG50-5050 角铝扣盖-50系列-5050		9.5	3.22.50.5050
PG50-50x100 (pcs) 50系列-50x100 (单个供货)		235	3.21.50.50100
PG50-50x100 (set H) 50系列-50x100 (成套供货H)	4xH	327	3.21.50.50100.STH
PG50-50x100 (set J) 50系列-50x100 (成套供货J)	4xJ	333	3.21.50.50100.STJ
PG50-50x100 (set K) 50系列-50x100 (成套供货K)	4xK	365	3.21.50.50100.STK
PG50-100x100 (pcs) 50系列-100x100 (单个供货)		484	3.21.50.100100
PG50-100x100 (set H) 50系列-100x100 (成套供货H)	8xH	668	3.21.50.100100.STH
PG50-100x100 (set J) 50系列-100x100 (成套供货J)	8xJ	680	3.21.50.100100.STJ
PG50-100x100 (set K) 50系列-100x100 (成套供货K)	8xK	744	3.21.50.100100.STK



Connecting Elements
 连接件

Angle Profile Bracket

挤压角铝





Material: aluminium, anodized (cutting end not anodized)

材质: 铝合金 表面处理: 阳极氧化(切面无处理)

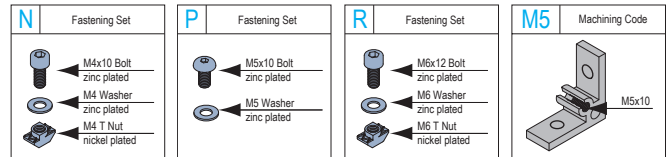
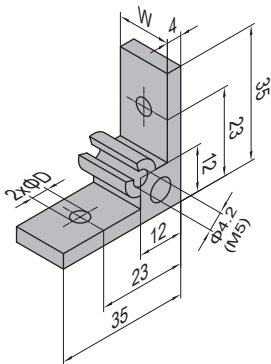

35x35x4



Application 应用	Description 产品描述	D (mm)	W (mm)	Fastening Set 紧固组件	Machining Code 加工代码	Mass 重量 (g)	Part No. 订购编号
PG15 15mm 	35-15-15 (pcs/单个供货)	4.5	10			8	3.31.35.15.15
	35-15-15 (set/成套供货)			2xN		20	3.31.35.15.15.ST
	35-15-15 (M5/加工供货)				M5	8	3.31.35.15.15.M5
	35-15-15 (M5 set/成套加工供货)			2xN+1xP	M5	22	3.31.35.15.15.M5.ST
PG15 30mm 	35-15-30 (pcs/单个供货)	4.5	25			21	3.31.35.15.30
	35-15-30 (set/成套供货)			2xN		33	3.31.35.15.30.ST
	35-15-30 (M5/加工供货)				M5	21	3.31.35.15.30.M5
	35-15-30 (M5 set/成套加工供货)			2xN+1xP	M5	35	3.31.35.15.30.M5.ST
PG20 20mm 	35-20-20 (pcs/单个供货)	4.5	14			12	3.31.35.20.20
	35-20-20 (set/成套供货)			2xN		24	3.31.35.20.20.ST
	35-20-20 (M5/加工供货)				M5	12	3.31.35.20.20.M5
	35-20-20 (M5 set/成套加工供货)			2xN+1xP	M5	26	3.31.35.20.20.M5.ST
PG30 30mm 	35-30-30 (pcs/单个供货)	6.5	22			19	3.31.35.30.30
	35-30-30 (set/成套供货)			2xR		42	3.31.35.30.30.ST
	35-30-30 (M5/加工供货)				M5	19	3.31.35.30.30.M5
	35-30-30 (M5 set/成套加工供货)			2xR+1xP	M5	44	3.31.35.30.30.M5.ST

Connecting Elements
 连接件

Angle Profile Bracket

挤压角铝







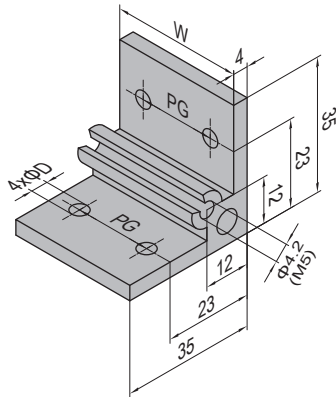

Material: aluminium, anodized (cutting end not anodized)



材质: 铝合金 表面处理: 阳极氧化(切面无处理)



35x35x4

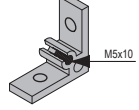

N	Fastening Set	P	Fastening Set	R	Fastening Set	M5	Machining Code
	 M4x10 Bolt zinc plated  M4 Washer zinc plated  M4 T Nut nickel plated	 M5x10 Bolt zinc plated  M5 Washer zinc plated	 M6x12 Bolt zinc plated  M6 Washer zinc plated  M6 T Nut nickel plated	 M5x10			

Application 应用	Description 产品描述	D (mm)	W (mm)	PG (mm)	Fastening Set 紧固组件	Machining Code 加工代码	Mass 重量 (g)	Part No. 订购编号
PG20 40mm 	35-20-40 (pcs/单个供货)	4.5	34	20			29	3.31.35.20.40
	35-20-40 (set/成套供货)				4xN		50	3.31.35.20.40.ST
	35-20-40 (M5/加工供货)					M5	29	3.31.35.20.40.M5
	35-20-40 (M5 set/成套加工供货)				4xN+1xP	M5	52	3.31.35.20.40.M5.ST
PG30 60mm 	35-30-60 (pcs/单个供货)	6.5	52	30			45	3.31.35.30.60
	35-30-60 (set/成套供货)				4xR		88	3.31.35.30.60.ST
	35-30-60 (M5/加工供货)					M5	45	3.31.35.30.60.M5
	35-30-60 (M5 set/成套加工供货)				4xR+1xP	M5	90	3.31.35.30.60.M5.ST

Connecting Elements
 连接件

Angle Profile Bracket

挤压角铝

Material: aluminium, anodized (cutting end not anodized)

材质: 铝合金 表面处理: 阳极氧化(切面无处理)



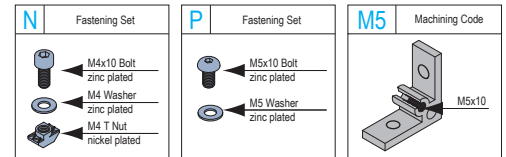
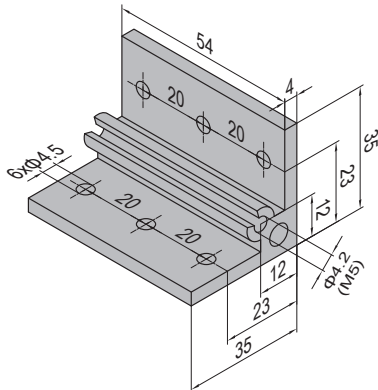

35x35x4

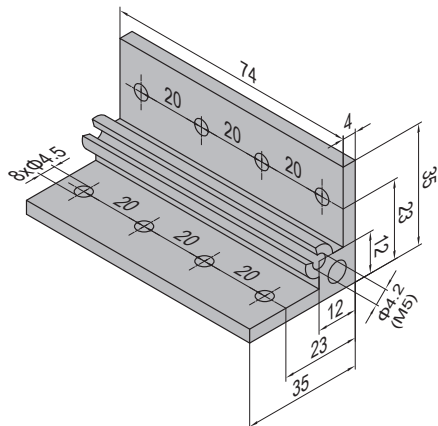

Application 应用	Description 产品描述	Fastening Set 紧固组件	Machining Code 加工代码	Mass 重量 (g)	Part No. 订购编号
PG20 60mm 	35-20-60 (pcs/单个供货)			47	3.31.35.20.60
	35-20-60 (set/成套供货)	6xN		77	3.31.35.20.60.ST
	35-20-60 (M5/加工供货)		M5	47	3.31.35.20.60.M5
	35-20-60 (M5 set/成套加工供货)	6xN+1xP	M5	79	3.31.35.20.60.M5.ST

35x35x4



Application 应用	Description 产品描述	Fastening Set 紧固组件	Machining Code 加工代码	Mass 重量 (g)	Part No. 订购编号
PG20 80mm 	35-20-80 (pcs/单个供货)			64	3.31.35.20.80
	35-20-80 (set/成套供货)	8xN		103	3.31.35.20.80.ST
	35-20-80 (M5/加工供货)		M5	64	3.31.35.20.80.M5
	35-20-80 (M5 set/成套加工供货)	8xN+1xP	M5	105	3.31.35.20.80.M5.ST

Connecting Elements
 连接件

Angle Profile Bracket

挤压角铝







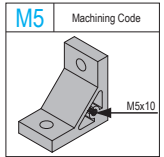
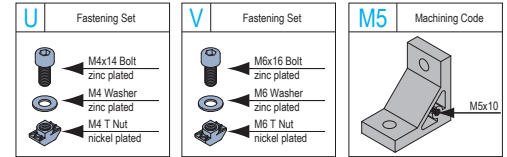
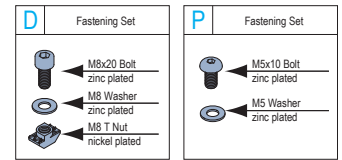
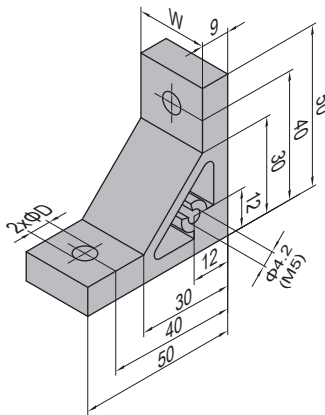

Material: aluminium, anodized (cutting end not anodized)

材质: 铝合金 表面处理: 阳极氧化(切面无处理)



50x50x9



Application 应用	Description 产品描述	D (mm)	W (mm)	Fastening Set 紧固组件	Machining Code 加工代码	Mass 重量 (g)	Part No. 订购编号
PG20 20mm 	50-20-20 (pcs/单个供货)	4.5	14			31	3.31.50.20.20
	50-20-20 (set/成套供货)			2xU		43	3.31.50.20.20.ST
	50-20-20 (M5/加工供货)				M5	31	3.31.50.20.20.M5
	50-20-20 (M5 set/成套加工供货)			2xU+1xP	M5	45	3.31.50.20.20.M5.ST
PG30 30mm 	50-30-30 (pcs/单个供货)	6.5	22			48	3.31.50.30.30
	50-30-30 (set/成套供货)			2xV		71	3.31.50.30.30.ST
	50-30-30 (M5/加工供货)				M5	48	3.31.50.30.30.M5
	50-30-30 (M5 set/成套加工供货)			2xV+1xP	M5	73	3.31.50.30.30.M5.ST
PG40 40mm 	50-40-40 (pcs/单个供货)	8.5	30			66	3.31.50.40.40
	50-40-40 (set/成套供货)			2xD		112	3.31.50.40.40.ST
	50-40-40 (M5/加工供货)				M5	66	3.31.50.40.40.M5
	50-40-40 (M5 set/成套加工供货)			2xD+1xP	M5	114	3.31.50.40.40.M5.ST
PG40 60mm 	50-40-60 (pcs/单个供货)	8.5	50			110	3.31.50.40.60
	50-40-60 (set/成套供货)			2xD		156	3.31.50.40.60.ST
	50-40-60 (M5/加工供货)				M5	110	3.31.50.40.60.M5
	50-40-60 (M5 set/成套加工供货)			2xD+1xP	M5	158	3.31.50.40.60.M5.ST
PG45 45mm 	50-45-45 (pcs/单个供货)	8.5	35			77	3.31.50.45.45
	50-45-45 (set/成套供货)			2xD		123	3.31.50.45.45.ST
	50-45-45 (M5/加工供货)				M5	77	3.31.50.45.45.M5
	50-45-45 (M5 set/成套加工供货)			2xD+1xP	M5	125	3.31.50.45.45.M5.ST
PG45 60mm 	50-45-60 (pcs/单个供货)	8.5	50			110	3.31.50.45.60
	50-45-60 (set/成套供货)			2xD		156	3.31.50.45.60.ST
	50-45-60 (M5/加工供货)				M5	110	3.31.50.45.60.M5
	50-45-60 (M5 Set/成套加工供货)			2xD+1xP	M5	158	3.31.50.45.60.M5.ST
PG50 50mm 	50-50-50 (pcs/单个供货)	8.5	40			88	3.31.50.50.50
	50-50-50 (set/成套供货)			2xD		134	3.31.50.50.50.ST
	50-50-50 (M5/加工供货)				M5	88	3.31.50.50.50.M5
	50-50-50 (M5 Set/成套加工供货)			2xD+1xP	M5	136	3.31.50.50.50.M5.ST
PG60 60mm 	50-60-60 (pcs/单个供货)	8.5	50			110	3.31.50.60.60
	50-60-60 (set/成套供货)			2xD		156	3.31.50.60.60.ST
	50-60-60 (M5/加工供货)				M5	110	3.31.50.60.60.M5
	50-60-60 (M5 Set/成套加工供货)			2xD+1xP	M5	158	3.31.50.60.60.M5.ST



Connecting Elements
连接件
Angle Profile Bracket
挤压角铝

Material: aluminium, anodized (cutting end not anodized)

材质: 铝合金 表面处理: 阳极氧化(切面无处理)



50x50x9

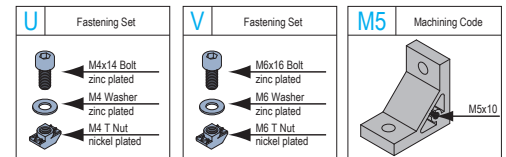
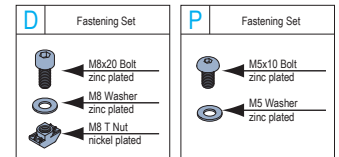
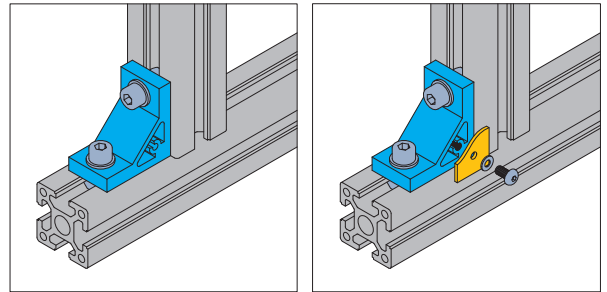
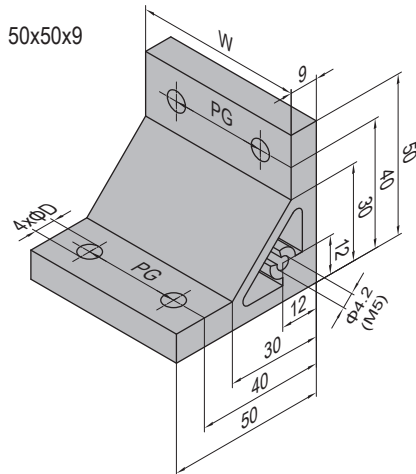

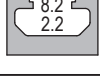
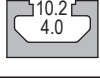
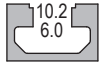
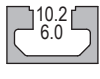
Application 应用	Description 产品描述	D (mm)	W (mm)	PG (mm)	Fastening Set 紧固组件	Machining Code 加工代码	Mass 重量 (g)	Part No. 订购编号
PG20 40mm 	50-20-40 (pcs/单个供货)	4.5	34	20			75	3.31.50.20.40
	50-20-40 (set/成套供货)				4xU		95	3.31.50.20.40.ST
	50-20-40 (M5/加工供货)					M5	75	3.31.50.20.40.M5
	50-20-40 (M5 set/成套加工供货)				4xU+1xP	M5	97	3.31.50.20.40.M5.ST
PG30 60mm 	50-30-60 (pcs/单个供货)	6.5	52	30			114	3.31.50.30.60
	50-30-60 (set/成套供货)				4xV		156	3.31.50.30.60.ST
	50-30-60 (M5/加工供货)					M5	114	3.31.50.30.60.M5
	50-30-60 (M5 set/成套加工供货)				4xV+1xP	M5	158	3.31.50.30.60.M5.ST
PG40 80mm 	50-40-80 (pcs/单个供货)	8.5	70	40			154	3.31.50.40.80
	50-40-80 (set/成套供货)				4xD		240	3.31.50.40.80.ST
	50-40-80 (M5/加工供货)					M5	154	3.31.50.40.80.M5
	50-40-80 (M5 set/成套加工供货)				4xD+1xP	M5	242	3.31.50.40.80.M5.ST
PG45 90mm 	50-45-90 (pcs/单个供货)	8.5	80	45			176	3.31.50.45.90
	50-45-90 (set/成套供货)				4xD		262	3.31.50.45.90.ST
	50-45-90 (M5/加工供货)					M5	176	3.31.50.45.90.M5
	50-45-90 (M5 set/成套加工供货)				4xD+1xP	M5	264	3.31.50.45.90.M5.ST
PG50 100mm 	50-50-100 (pcs/单个供货)	8.5	90	50			198	3.31.50.50.100
	50-50-100 (set/成套供货)				4xD		284	3.31.50.50.100.ST
	50-50-100 (M5/加工供货)					M5	198	3.31.50.50.100.M5
	50-50-100 (M5 set/成套加工供货)				4xD+1xP	M5	286	3.31.50.50.100.M5.ST



Connecting Elements
连接件

Angle Profile Bracket

挤压角铝

Material: aluminium, anodized (cutting end not anodized)

材质: 铝合金 表面处理: 阳极氧化(切面无处理)



50x50x9

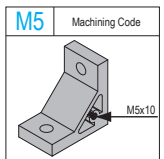
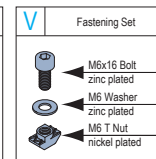
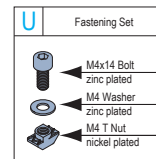
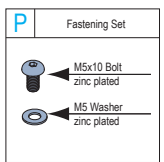
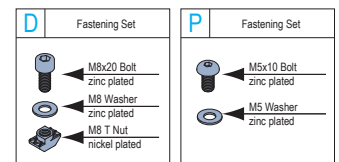
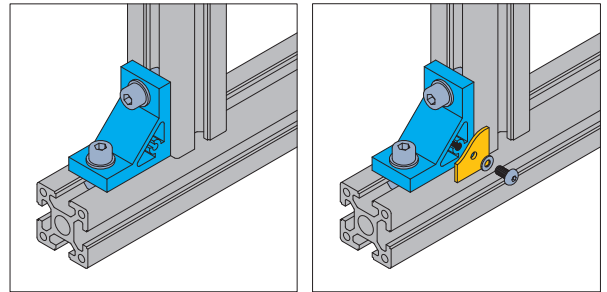
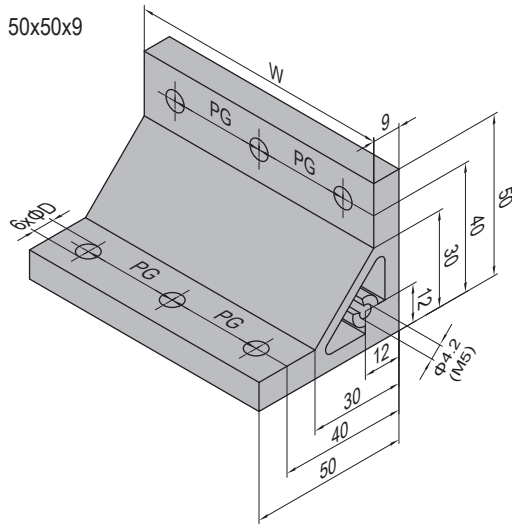

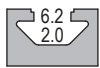
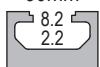
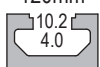
Application 应用	Description 产品描述	D (mm)	W (mm)	PG (mm)	Fastening Set 紧固组件	Machining Code 加工代码	Mass 重量 (g)	Part No. 订购编号
PG20 60mm 	50-20-60 (pcs/单个供货)	4.5	54	20			119	3.31.50.20.60
	50-20-60 (set/成套供货)				6xD		147	3.31.50.20.60.ST
	50-20-60 (M5/加工供货)					M5	119	3.31.50.20.60.M5
	50-20-60 (M5 set/成套加工供货)				6xU+1xP	M5	149	3.31.50.20.60.M5.ST
PG30 90mm 	50-30-90 (pcs/单个供货)	6.5	82	30			180	3.31.50.30.90
	50-30-90 (set/成套供货)				6xV		241	3.31.50.30.90.ST
	50-30-90 (M5/加工供货)					M5	180	3.31.50.30.90.M5
	50-30-90 (M5 set/成套加工供货)				6xV+1xP	M5	243	3.31.50.30.90.M5.ST
PG40 120mm 	50-40-120 (pcs/单个供货)	8.5	110	40			242	3.31.50.40.120
	50-40-120 (set/成套供货)				6xD		372	3.31.50.40.120.ST
	50-40-120 (M5/加工供货)					M5	242	3.31.50.40.120.M5
	50-40-120 (M5 set/成套加工供货)				6xD+1xP	M5	374	3.31.50.40.120.M5.ST



Connecting Elements
连接件
Angle Profile Bracket
挤压角铝

Material: aluminium, anodized (cutting end not anodized)

材质: 铝合金 表面处理: 阳极氧化(切面无处理)



50x50x9

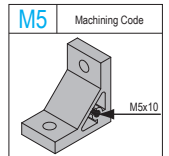
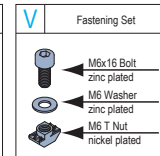
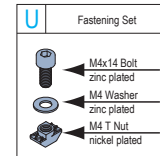
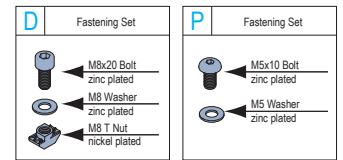
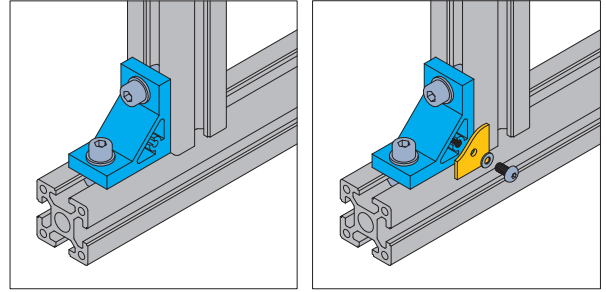
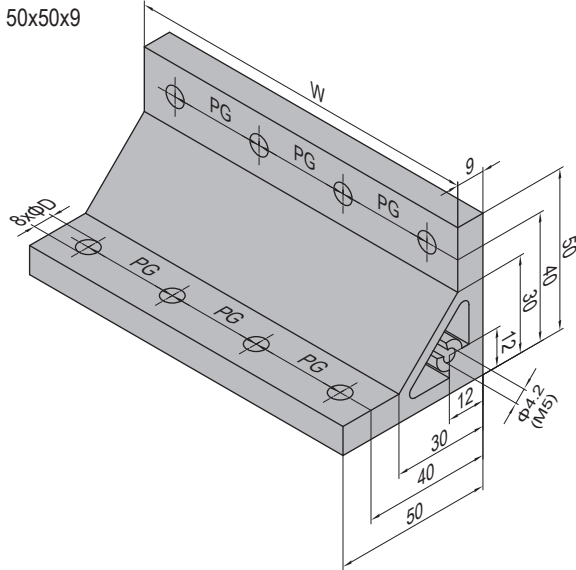

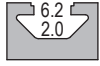
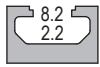
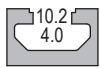
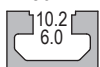
Application 应用	Description 产品描述	D (mm)	W (mm)	PG (mm)	Fastening Set 紧固组件	Machining Code 加工代码	Mass 重量 (g)	Part No. 订购编号
PG20 80mm 	50-20-80 (pcs/单个供货)	4.5	74	20			163	3.31.50.20.80
	50-20-80 (set/成套供货)				8xU		199	3.31.50.20.80.ST
	50-20-80 (M5/加工供货)					M5	163	3.31.50.20.80.M5
	50-20-80 (M5 set/成套加工供货)				8xU+1xP	M5	201	3.31.50.20.80.M5.ST
PG30 120mm 	50-30-120 (pcs/单个供货)	6.5	112	30			246	3.31.50.30.120
	50-30-120 (set/成套供货)				8xV		326	3.31.50.30.120.ST
	50-30-120 (M5/加工供货)					M5	246	3.31.50.30.120.M5
	50-30-120 (M5 set/成套加工供货)				8xV+1xP	M5	328	3.31.50.30.120.M5.ST
PG40 160mm 	50-40-160 (pcs/单个供货)	8.5	150	40			330	3.31.50.40.160
	50-40-160 (set/成套供货)				8xD		502	3.31.50.40.160.ST
	50-40-160 (M5/加工供货)					M5	330	3.31.50.40.160.M5
	50-40-160 (M5 set/成套加工供货)				8xD+1xP	M5	504	3.31.50.40.160.M5.ST
PG45 180mm 	50-45-180 (pcs/单个供货)	8.5	170	45			374	3.31.50.45.180
	50-45-180 (set/成套供货)				8xD		546	3.31.50.45.180.ST
	50-45-180 (M5/加工供货)					M5	374	3.31.50.45.180.M5
	50-45-180 (M5 set/成套加工供货)				8xD+1xP	M5	548	3.31.50.45.180.M5.ST



Connecting Elements
 连接件

 Angle Profile Bracket
 挤压角铝

 Material: aluminium, anodized (cutting end not anodized)
 材质: 铝合金 表面处理: 阳极氧化(切面无处理)

70x70x9-135°

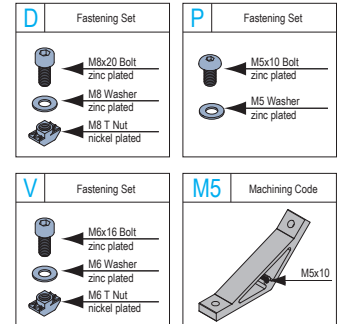
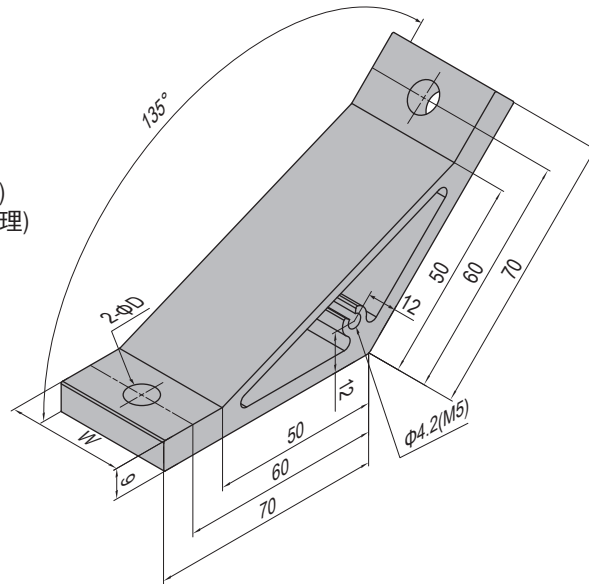

Application 应用	Description 产品描述	D (mm)	W (mm)	Fastening Set 紧固组件	Machining Code 加工代码	Mass 重量 (g)	Part No. 订购编号
PG30 30mm 	70-30-30 (pcs/单个供货)	7	22			71	3.31.70.30.30
	70-30-30 (set/成套供货)			2xD		94	3.31.70.30.30.ST
	70-30-30 (M5/加工供货)				M5	71	3.31.70.30.30.M5
	70-30-30 (M5 set/成套加工供货)			2xD+1xP	M5	96	3.31.70.30.30.M5.ST
PG40 40mm 	70-40-40 (pcs/单个供货)	9	30			96	3.31.70.40.40
	70-40-40 (set/成套供货)			2xD		142	3.31.70.40.40.ST
	70-40-40 (M5/加工供货)				M5	96	3.31.70.40.40.M5
	70-40-40 (M5 set/成套加工供货)			2xD+1xP	M5	144	3.31.70.40.40.M5.ST
PG40 60mm 	70-40-60 (pcs/单个供货)	9	50			166	3.31.70.40.60
	70-40-60 (set/成套供货)			2xD		212	3.31.70.40.60.ST
	70-40-60 (M5/加工供货)				M5	166	3.31.70.40.60.M5
	70-40-60 (M5 set/成套加工供货)			2xD+1xP	M5	214	3.31.70.40.60.M5.ST
PG45 45mm 	70-45-45 (pcs/单个供货)	9	35			113	3.31.70.45.45
	70-45-45 (set/成套供货)			2xD		159	3.31.70.45.45.ST
	70-45-45 (M5/加工供货)				M5	113	3.31.70.45.45.M5
	70-45-45 (M5 set/成套加工供货)			2xD+1xP	M5	161	3.31.70.45.45.M5.ST
PG45 60mm 	70-45-60 (pcs/单个供货)	9	50			166	3.31.70.45.60
	70-45-60 (set/成套供货)			2xD		212	3.31.70.45.60.ST
	70-45-60 (M5/加工供货)				M5	166	3.31.70.45.60.M5
	70-45-60 (M5 Set/成套加工供货)			2xD+1xP	M5	214	3.31.70.45.60.M5.ST
PG50 50mm 	70-50-50 (pcs/单个供货)	9	40			131	3.31.70.50.50
	70-50-50 (set/成套供货)			2xD		177	3.31.70.50.50.ST
	70-50-50 (M5/加工供货)				M5	131	3.31.70.50.50.M5
	70-50-50 (M5 Set/成套加工供货)			2xD+1xP	M5	179	3.31.70.50.50.M5.ST
PG60 60mm 	70-60-60 (pcs/单个供货)	9	50			166	3.31.70.60.60
	70-60-60 (set/成套供货)			2xD		212	3.31.70.60.60.ST
	70-60-60 (M5/加工供货)				M5	166	3.31.70.60.60.M5
	70-60-60 (M5 Set/成套加工供货)			2xD+1xP	M5	214	3.31.70.60.60.M5.ST



Connecting Elements
连接件

Angle Profile Bracket
挤压角铝



Material: aluminium, anodized (cutting end not anodized)
材质: 铝合金 表面处理: 阳极氧化(切面无处理)



70x70x9-135°

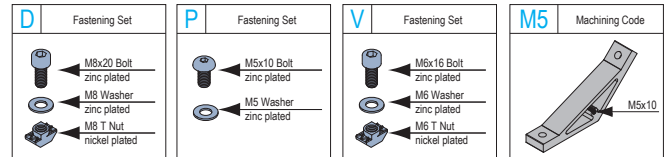
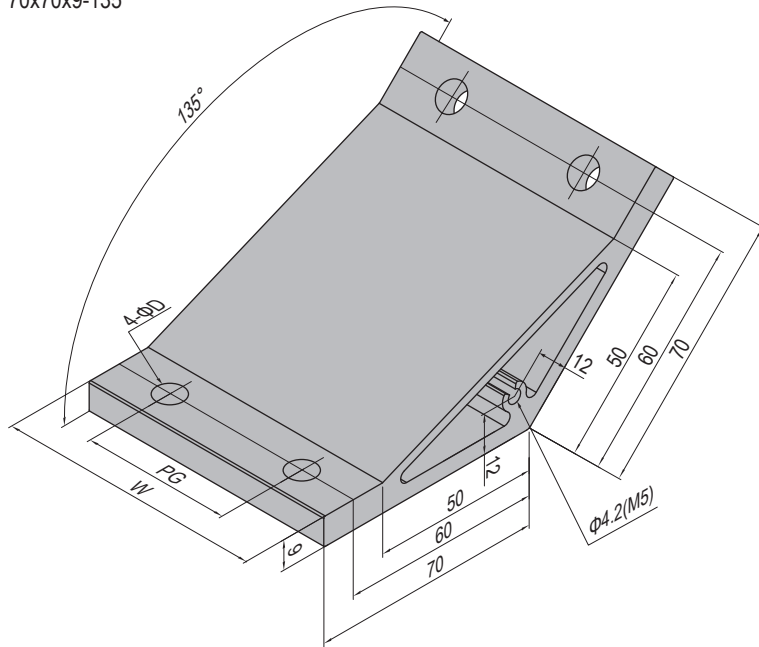

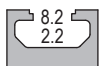
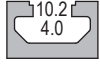
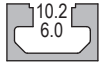
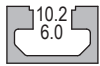
Application 应用	Description 产品描述	D (mm)	W (mm)	PG (mm)	Fastening Set 紧固组件	Machining Code 加工代码	Mass 重量 (g)	Part No. 订购编号
PG30 60mm 	70-30-60 (pcs/单个供货)	7	52	30			171	3.31.70.30.60
	70-30-60 (set/成套供货)				4xD		213	3.31.70.30.60.ST
	70-30-60 (M5/加工供货)					M5	171	3.31.70.30.60.M5
	70-30-60 (M5 set/成套加工供货)				4xV+1xP	M5	215	3.31.70.30.60.M5.ST
PG40 80mm 	70-40-80 (pcs/单个供货)	9	70	40			227	3.31.70.40.80
	70-40-80 (set/成套供货)				4xD		313	3.31.70.40.80.ST
	70-40-80 (M5/加工供货)					M5	227	3.31.70.40.80.M5
	70-40-80 (M5 set/成套加工供货)				4xD+1xP	M5	315	3.31.70.40.80.M5.ST
PG45 90mm 	70-45-90 (pcs/单个供货)	9	80	45			262	3.31.70.45.90
	70-45-90 (set/成套供货)				4xD		348	3.31.70.45.90.ST
	70-45-90 (M5/加工供货)					M5	262	3.31.70.45.90.M5
	70-45-90 (M5 set/成套加工供货)				4xD+1xP	M5	350	3.31.70.45.90.M5.ST
PG50 100mm 	70-50-100 (pcs/单个供货)	9	90	50			297	3.31.70.50.100
	70-50-100 (set/成套供货)				4xD		383	3.31.70.50.100.ST
	70-50-100 (M5/加工供货)					M5	297	3.31.70.50.100.M5
	70-50-100 (M5 set/成套加工供货)				4xD+1xP	M5	385	3.31.70.50.100.M5.ST











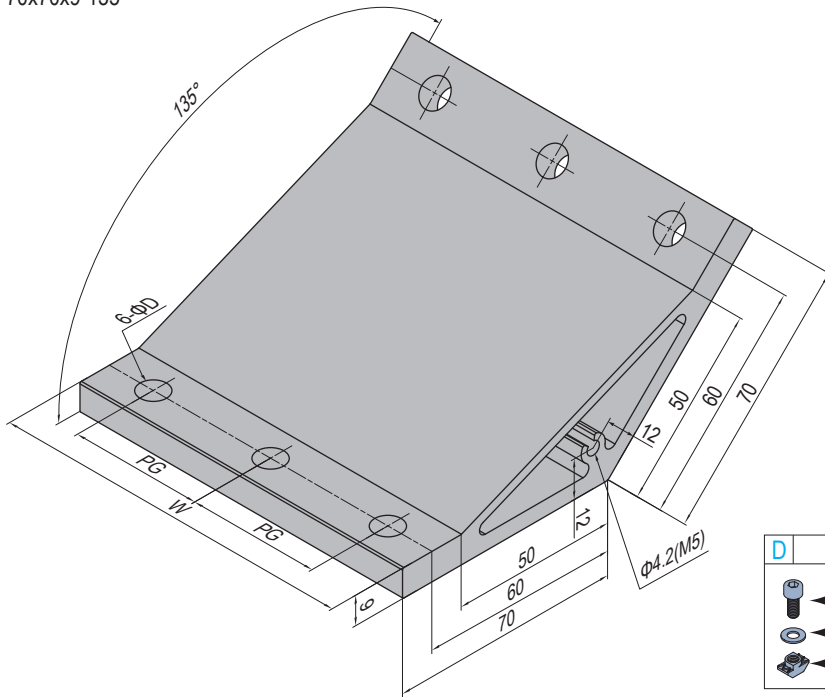

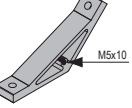

Connecting Elements
 连接件

 Angle Profile Bracket
 挤压角铝

 Material: aluminium, anodized (cutting end not anodized)
 材质: 铝合金 表面处理: 阳极氧化(切面无处理)

70x70x9-135°

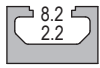
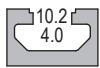

D	Fastening Set	P	Fastening Set	V	Fastening Set	M5	Machining Code
	M8x20 Bolt zinc plated		M5x10 Bolt zinc plated		M6x16 Bolt zinc plated		
	M8 Washer zinc plated		M5 Washer zinc plated		M6 Washer zinc plated		
	M8 T.Nut nickel plated		M5 T.Nut zinc plated		M6 T.Nut nickel plated		

Application 应用	Description 产品描述	D (mm)	W (mm)	PG (mm)	Fastening Set 紧固组件	Machining Code 加工代码	Mass 重量 (g)	Part No. 订购编号
PG30 90mm 	70-30-90 (pcs/单个供货)	7	82	30			270	3.31.70.30.90
	70-30-90 (set/成套供货)				6xV		331	3.31.70.30.90.ST
	70-30-90 (M5/加工供货)					M5	270	3.31.70.30.90.M5
	70-30-90 (M5 set/成套加工供货)				6xV+1xP	M5	333	3.31.70.30.90.M5.ST
PG40 120mm 	70-40-120 (pcs/单个供货)	9	110	40			357	3.31.70.40.120
	70-40-120 (set/成套供货)				6xD		487	3.31.70.40.120.ST
	70-40-120 (M5/加工供货)					M5	357	3.31.70.40.120.M5
	70-40-120 (M5 set/成套加工供货)				6xD+1xP	M5	489	3.31.70.40.120.M5.ST

Connecting Elements
连接件

Angle Profile Bracket
挤压角铝





Material: aluminium, anodized (cutting end not anodized)
材质: 铝合金 表面处理: 阳极氧化(切面无处理)

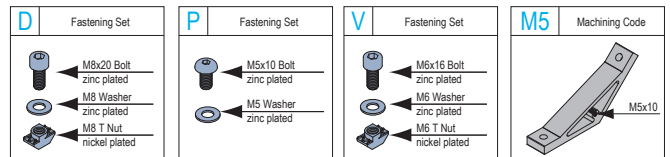
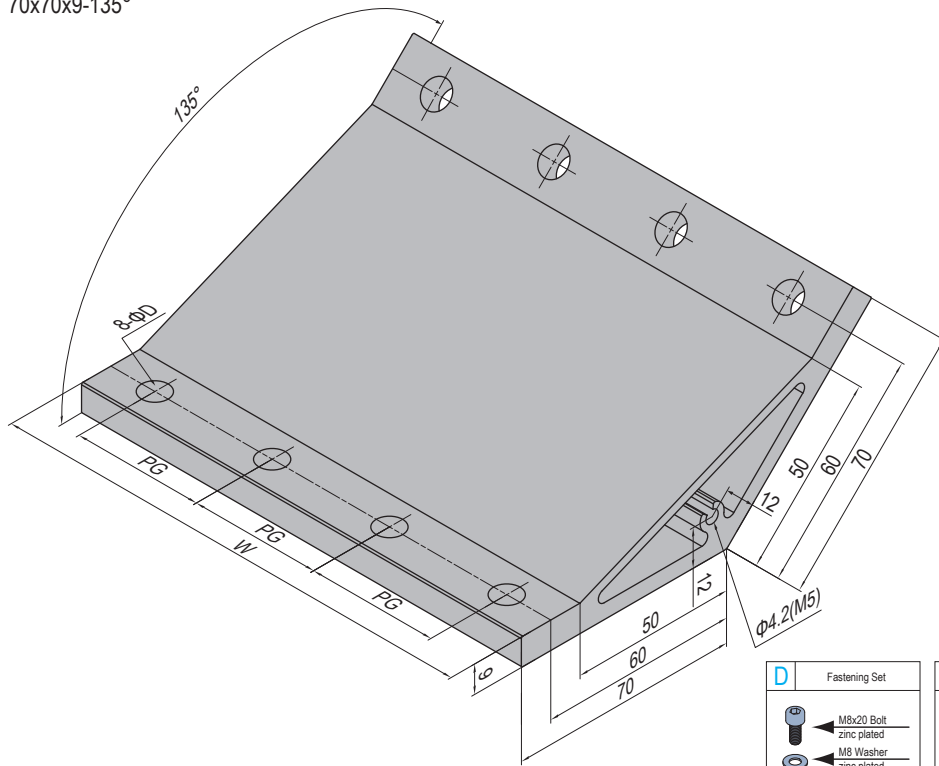

70x70x9-135°



Application 应用	Description 产品描述	D (mm)	W (mm)	PG (mm)	Fastening Set 紧固组件	Machining Code 加工代码	Mass 重量 (g)	Part No. 订购编号
PG30 120mm 	70-30-120 (pcs/单个供货)	7	112	30			369	3.31.70.30.120
	70-30-120 (set/成套供货)				8xV		449	3.31.70.30.120.ST
	70-30-120 (M5/加工供货)					M5	369	3.31.70.30.120.M5
	70-30-120 (M5 set/成套加工供货)				8xV+1xP	M5	451	3.31.70.30.120.M5.ST
PG40 160mm 	70-40-160 (pcs/单个供货)	9	150	40			488	3.31.70.40.160
	70-40-160 (set/成套供货)				8xD		660	3.31.70.40.160.ST
	70-40-160 (M5/加工供货)					M5	488	3.31.70.40.160.M5
	70-40-160 (M5 set/成套加工供货)				8xD+1xP	M5	662	3.31.70.40.160.M5.ST
PG45 180mm 	70-45-180 (pcs/单个供货)	9	170	45			558	3.31.70.45.180
	70-45-180 (set/成套供货)				8xD		730	3.31.70.45.180.ST
	70-45-180 (M5/加工供货)					M5	558	3.31.70.45.180.M5
	70-45-180 (M5 set/成套加工供货)				8xD+1xP	M5	732	3.31.70.45.180.M5.ST





Connecting Elements
 连接件

 Angle Profile Bracket
 挤压角铝

 Material: aluminium, anodized (cutting end not anodized)
 材质: 铝合金 表面处理: 阳极氧化(切面无处理)

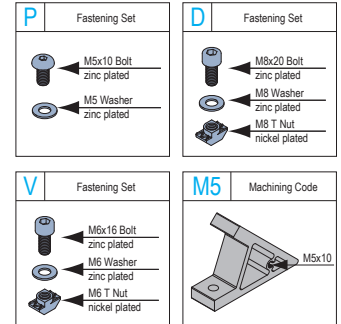
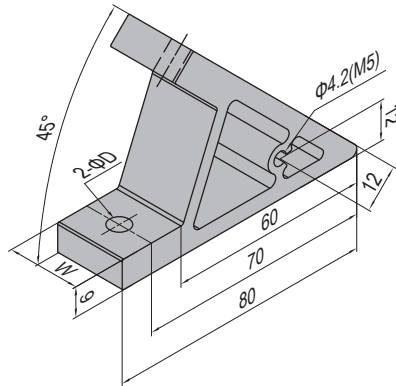
80x80x9-45°



Application 应用	Description 产品描述	D (mm)	W (mm)	Fastening Set 紧固组件	Machining Code 加工代码	Mass 重量 (g)	Part No. 订购编号
PG30 30mm 	80-30-30 (pcs/单个供货)	7	22			68	3.31.80.30.30
	80-30-30 (set/成套供货)			2xV		91	3.31.80.30.30.ST
	80-30-30 (M5/加工供货)				M5	68	3.31.80.30.30.M5
	80-30-30 (M5 set/成套加工供货)			2xV+1xP	M5	93	3.31.80.30.30.M5.ST
PG40 40mm 	80-40-40 (pcs/单个供货)	9	30			89	3.31.80.40.40
	80-40-40 (set/成套供货)			2xD		135	3.31.80.40.40.ST
	80-40-40 (M5/加工供货)				M5	89	3.31.80.40.40.M5
	80-40-40 (M5 set/成套加工供货)			2xD+1xP	M5	137	3.31.80.40.40.M5.ST
PG40 60mm 	80-40-60 (pcs/单个供货)	9	50			151	3.31.80.40.60
	80-40-60 (set/成套供货)			2xD		197	3.31.80.40.60.ST
	80-40-60 (M5/加工供货)				M5	151	3.31.80.40.60.M5
	80-40-60 (M5 set/成套加工供货)			2xD+1xP	M5	199	3.31.80.40.60.M5.ST
PG45 45mm 	80-45-45 (pcs/单个供货)	9	35			105	3.31.80.45.45
	80-45-45 (set/成套供货)			2xD		151	3.31.80.45.45.ST
	80-45-45 (M5/加工供货)				M5	105	3.31.80.45.45.M5
	80-45-45 (M5 set/成套加工供货)			2xD+1xP	M5	153	3.31.80.45.45.M5.ST
PG45 60mm 	80-45-60 (pcs/单个供货)	9	50			151	3.31.80.45.60
	80-45-60 (set/成套供货)			2xD		197	3.31.80.45.60.ST
	80-45-60 (M5/加工供货)				M5	151	3.31.80.45.60.M5
	80-45-60 (M5 set/成套加工供货)			2xD+1xP	M5	199	3.31.80.45.60.M5.ST
PG50 50mm 	80-50-50 (pcs/单个供货)	9	40			120	3.31.80.50.50
	80-50-50 (set/成套供货)			2xD		166	3.31.80.50.50.ST
	80-50-50 (M5/加工供货)				M5	120	3.31.80.50.50.M5
	80-50-50 (M5 Set/成套加工供货)			2xD+1xP	M5	168	3.31.80.50.50.M5.ST
PG60 60mm 	80-60-60 (pcs/单个供货)	9	50			151	3.31.80.60.60
	80-60-60 (set/成套供货)			2xD		197	3.31.80.60.60.ST
	80-60-60 (M5/加工供货)				M5	151	3.31.80.60.60.M5
	80-60-60 (M5 Set/成套加工供货)			2xD+1xP	M5	199	3.31.80.60.60.M5.ST











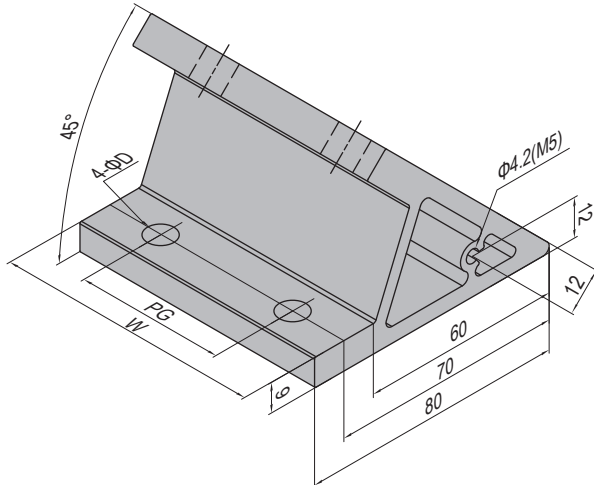

Connecting Elements
 连接件

 Angle Profile Bracket
 挤压角铝

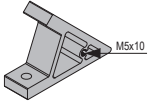
 Material: aluminium, anodized (cutting end not anodized)
 材质: 铝合金 表面处理: 阳极氧化(切面无处理)

80x80x9-45°

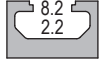
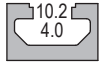
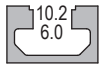
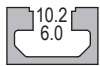

D	Fastening Set	P	Fastening Set	V	Fastening Set	M5	Machining Code
	M8x20 Bolt zinc plated		M5x10 Bolt zinc plated		M6x16 Bolt zinc plated		
	M8 Washer zinc plated		M5 Washer zinc plated		M6 Washer zinc plated		
	M8 T Nut nickel plated				M6 T Nut nickel plated		

Application 应用	Description 产品描述	D (mm)	W (mm)	PG (mm)	Fastening Set 紧固组件	Machining Code 加工代码	Mass 重量 (g)	Part No. 订购编号
PG30 60mm 	80-30-60 (pcs/单个供货)	7	52	30			156	3.31.80.30.60
	80-30-60 (set/成套供货)				4xV		198	3.31.80.30.60.ST
	80-30-60 (M5/加工供货)					M5	156	3.31.80.30.60.M5
	80-30-60 (M5 set/成套加工供货)				4xV+1xP	M5	200	3.31.80.30.60.M5.ST
PG40 80mm 	80-40-80 (pcs/单个供货)	9	70	40			209	3.31.80.40.80
	80-40-80 (set/成套供货)				4xD		295	3.31.80.40.80.ST
	80-40-80 (M5/加工供货)					M5	209	3.31.80.40.80.M5
	80-40-80 (M5 set/成套加工供货)				4xD+1xP	M5	297	3.31.80.40.80.M5.ST
PG45 90mm 	80-45-90 (pcs/单个供货)	9	80	45			240	3.31.80.45.90
	80-45-90 (set/成套供货)				4xD		326	3.31.80.45.90.ST
	80-45-90 (M5/加工供货)					M5	240	3.31.80.45.90.M5
	80-45-90 (M5 set/成套加工供货)				4xD+1xP	M5	328	3.31.80.45.90.M5.ST
PG50 100mm 	80-50-100 (pcs/单个供货)	9	90	50			271	3.31.80.50.100
	80-50-100 (set/成套供货)				4xD		357	3.31.80.50.100.ST
	80-50-100 (M5/加工供货)					M5	271	3.31.80.50.100.M5
	80-50-100 (M5 set/成套加工供货)				4xD+1xP	M5	359	3.31.80.50.100.M5.ST



Connecting Elements
连接件

Angle Profile Bracket
挤压角铝









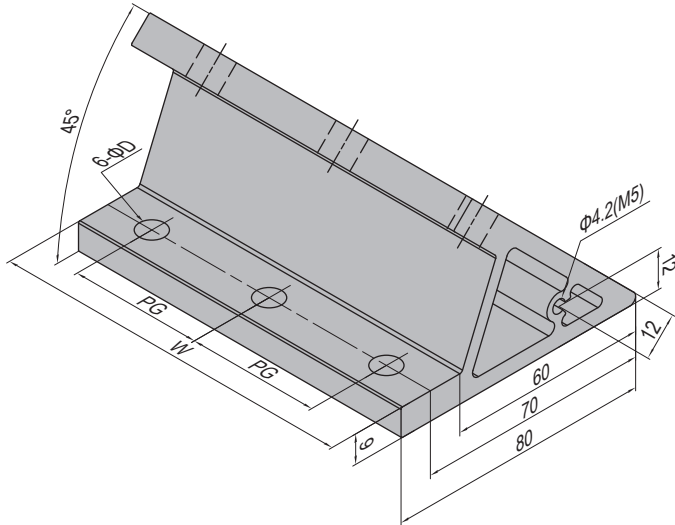

Material: aluminium, anodized (cutting end not anodized)
材质: 铝合金 表面处理: 阳极氧化(切面无处理)



80x80x9-45°

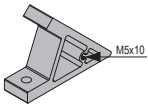

D Fastening Set	P Fastening Set	V Fastening Set	M5 Machining Code
 M8x20 Bolt zinc plated  M8 Washer zinc plated  M8 T Nut nickel plated	 M5x10 Bolt zinc plated  M5 Washer zinc plated	 M6x16 Bolt zinc plated  M6 Washer zinc plated  M6 T Nut nickel plated	 M5x10

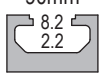
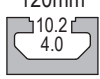
Application 应用	Description 产品描述	D (mm)	W (mm)	PG (mm)	Fastening Set 紧固组件	Machining Code 加工代码	Mass 重量 (g)	Part No. 订购编号
PG30 90mm 	80-30-90 (pcs/单个供货)	7	82	30			247	3.31.80.30.90
	80-30-90 (set/成套供货)				6xV		308	3.31.80.30.90.ST
	80-30-90 (M5/加工供货)					M5	247	3.31.80.30.90.M5
	80-30-90 (M5 set/成套加工供货)				6xV+1xP	M5	310	3.31.80.30.90.M5.ST
PG40 120mm 	80-40-120 (pcs/单个供货)	9	110	40			329	3.31.80.40.120
	80-40-120 (set/成套供货)				6xD		459	3.31.80.40.120.ST
	80-40-120 (M5/加工供货)					M5	329	3.31.80.40.120.M5
	80-40-120 (M5 set/成套加工供货)				6xD+1xP	M5	461	3.31.80.40.120.M5.ST









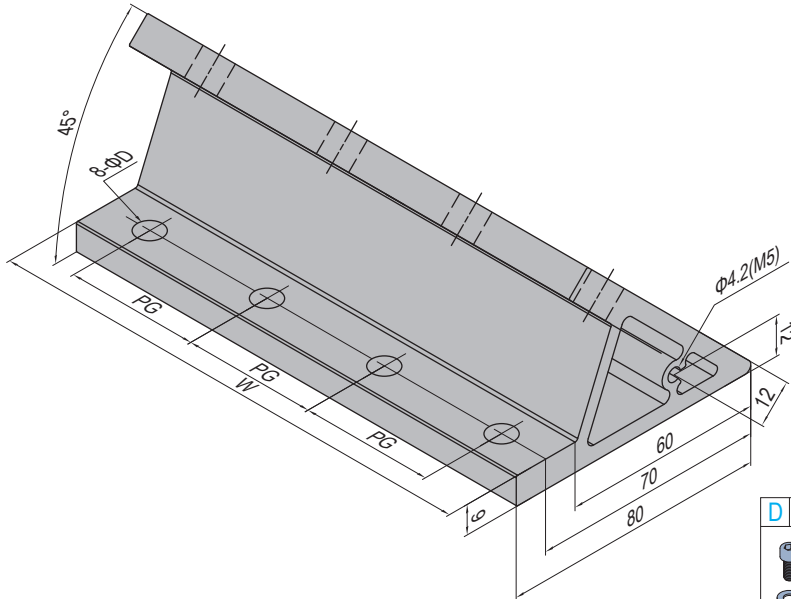

Connecting Elements
 连接件

 Angle Profile Bracket
 挤压角铝

 Material: aluminium, anodized (cutting end not anodized)
 材质: 铝合金 表面处理: 阳极氧化(切面无处理)

80x80x9-45°

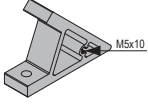

D Fastening Set	P Fastening Set	V Fastening Set	M5 Machining Code
 M8x20 Bolt zinc plated  M8 Washer zinc plated  M8 T Nut nickel plated	 M5x10 Bolt zinc plated  M5 Washer zinc plated	 M6x16 Bolt zinc plated  M6 Washer zinc plated  M6 T Nut nickel plated	 M5

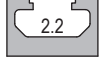
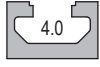
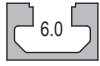
Application 应用	Description 产品描述	D (mm)	W (mm)	PG (mm)	Fastening Set 紧固组件	Machining Code 加工代码	Mass 重量 (g)	Part No. 订购编号
PG30 120mm  2.2	80-30-120 (pcs/单个供货)	7	112	30			337	3.31.80.30.120
	80-30-120 (set/成套供货)				8xV		417	3.31.80.30.120.ST
	80-30-120 (M5/加工供货)					M5	337	3.31.80.30.120.M5
	80-30-120 (M5 set/成套加工供货)				8xV+1xP	M5	419	3.31.80.30.120.M5.ST
PG40 160mm  4.0	80-40-160 (pcs/单个供货)	9	150	40			449	3.31.80.40.160
	80-40-160 (set/成套供货)				8xD		621	3.31.80.40.160.ST
	80-40-160 (M5/加工供货)					M5	449	3.31.80.40.160.M5
	80-40-160 (M5 set/成套加工供货)				8xD+1xP	M5	623	3.31.80.40.160.M5.ST
PG45 180mm  6.0	80-45-180 (pcs/单个供货)	9	170	45			510	3.31.80.45.180
	80-45-180 (set/成套供货)				8xD		682	3.31.80.45.180.ST
	80-45-180 (M5/加工供货)					M5	510	3.31.80.45.180.M5
	80-45-180 (M5 set/成套加工供货)				8xD+1xP	M5	684	3.31.80.45.180.M5.ST



Connecting Elements
连接件

Angle Profile Bracket

挤压角铝





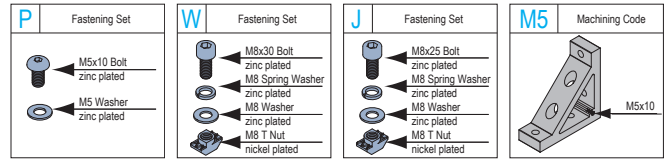
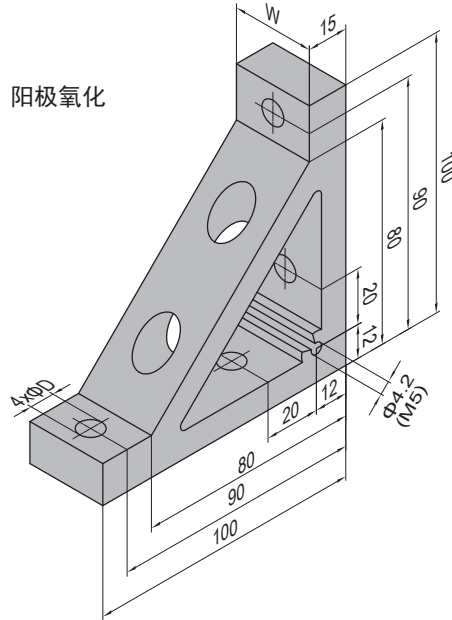

Material: aluminium, anodized

材质: 铝合金 表面处理: 阳极氧化

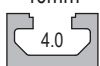

100x100x15

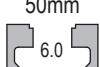

Application 应用	Description 产品描述	D (mm)	W (mm)	Fastening Set 紧固组件	Machining Code 加工代码	Mass 重量 (g)	Part No. 订购编号
PG40 40mm 	100-40-40 (pcs/单个供货)	9	30			220	3.31.100.40.40
	100-40-40 (set/成套供货)			2xW+2xJ		324	3.31.100.40.40.ST
	100-40-40 (M5/加工供货)				M5	220	3.31.100.40.40.M5
	100-40-40 (M5 set/成套加工供货)			2xW+2xJ+1xP	M5	326	3.31.100.40.40.M5.ST
PG40 60mm 	100-40-60 (pcs/单个供货)	9	50			386	3.31.100.40.60
	100-40-60 (set/成套供货)			2xW+2xJ		490	3.31.100.40.60.ST
	100-40-60 (M5/加工供货)				M5	386	3.31.100.40.60.M5
	100-40-60 (M5 set/成套加工供货)			2xW+2xJ+1xP	M5	492	3.31.100.40.60.M5.ST
PG45 45mm 	100-45-45 (pcs/单个供货)	9	35			261	3.31.100.45.45
	100-45-45 (set/成套供货)			2xW+2xJ		365	3.31.100.45.45.ST
	100-45-45 (M5/加工供货)				M5	261	3.31.100.45.45.M5
	100-45-45 (M5 set/成套加工供货)			2xW+2xJ+1xP	M5	367	3.31.100.45.45.M5.ST
PG45 60mm 	100-45-60 (pcs/单个供货)	9	50			386	3.31.100.45.60
	100-45-60 (set/成套供货)			2xW+2xJ		490	3.31.100.45.60.ST
	100-45-60 (M5/加工供货)				M5	386	3.31.100.45.60.M5
	100-45-60 (M5 set/成套加工供货)			2xW+2xJ+1xP	M5	492	3.31.100.45.60.M5.ST
PG50 50mm 	100-50-50 (pcs/单个供货)	9	40			303	3.31.100.50.50
	100-50-50 (set/成套供货)			2xW+2xJ		407	3.31.100.50.50.ST
	100-50-50 (M5/加工供货)				M5	303	3.31.100.50.50.M5
	100-50-50 (M5 set/成套加工供货)			2xW+2xJ+1xP	M5	409	3.31.100.50.50.M5.ST
PG60 60mm 	100-60-60 (pcs/单个供货)	9	50			386	3.31.100.60.60
	100-60-60 (set/成套供货)			2xW+2xJ		490	3.31.100.60.60.ST
	100-60-60 (M5/加工供货)				M5	386	3.31.100.60.60.M5
	100-60-60 (M5 Set/成套加工供货)			2xW+2xJ+1xP	M5	492	3.31.100.60.60.M5.ST



Connecting Elements
 连接件

Angle Profile Bracket

挤压角铝

Material: aluminium, anodized

材质: 铝合金 表面处理: 阳极氧化



100x100x15

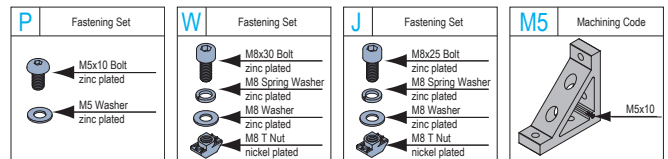
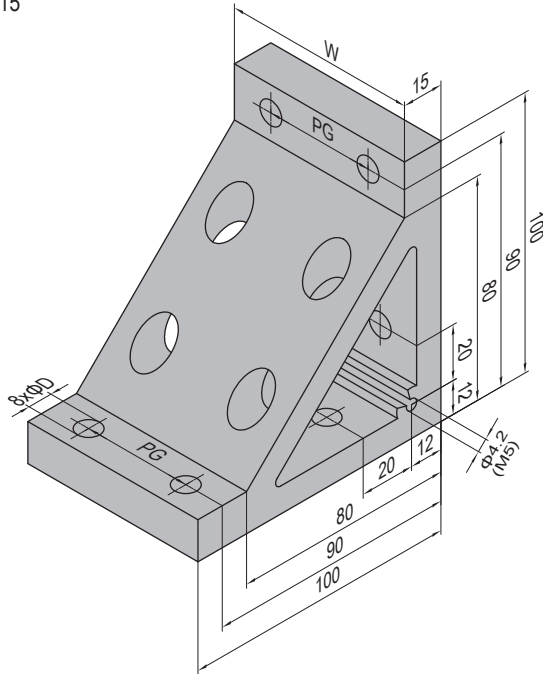

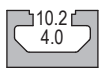
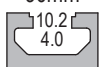
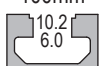
Application 应用	Description 产品描述	D (mm)	W (mm)	PG (mm)	Fastening Set 紧固组件	Machining Code 加工代码	Mass 重量 (g)	Part No. 订购编号
PG40 80mm 	100-40-80 (pcs/单个供货)	9	70	40			522	3.31.100.40.80
	100-40-80 (set/成套供货)				4xW+4xJ		730	3.31.100.40.80.ST
	100-40-80 (M5/加工供货)					M5	522	3.31.100.40.80.M5
	100-40-80 (M5 set/成套加工供货)				4xW+4xJ+1xP	M5	732	3.31.100.40.80.M5.ST
PG45 90mm 	100-45-90 (pcs/单个供货)	9	80	45			605	3.31.100.45.90
	100-45-90 (set/成套供货)				4xW+4xJ		813	3.31.100.45.90.ST
	100-45-90 (M5/加工供货)					M5	605	3.31.100.45.90.M5
	100-45-90 (M5 set/成套加工供货)				4xW+4xJ+1xP	M5	815	3.31.100.45.90.M5.ST
PG50 100mm 	100-50-100 (pcs/单个供货)	9	90	50			688	3.31.100.50.100
	100-50-100 (set/成套供货)				4xW+4xJ		896	3.31.100.50.100.ST
	100-50-100 (M5/加工供货)					M5	688	3.31.100.50.100.M5
	100-50-100 (M5 set/成套加工供货)				4xW+4xJ+1xP	M5	898	3.31.100.50.100.M5.ST



Connecting Elements
 连接件

Angle Profile Bracket

挤压角铝









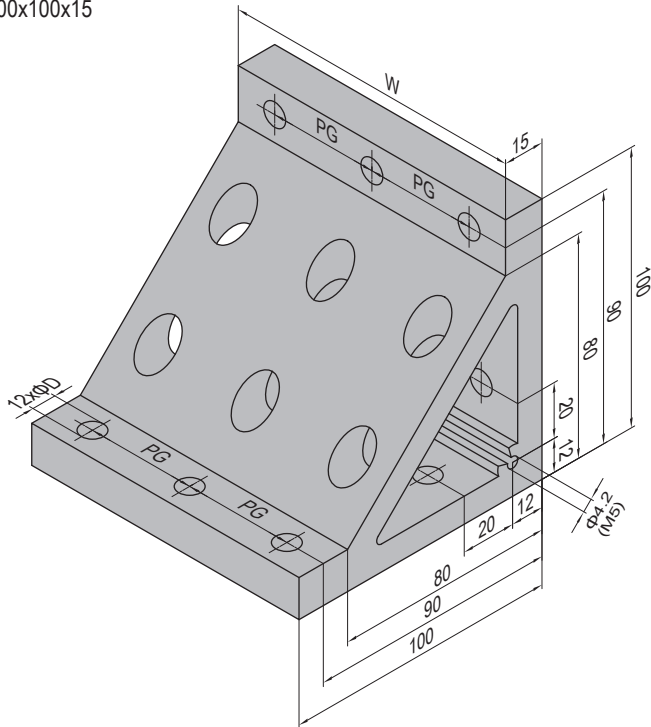

Material: aluminium, anodized

材质: 铝合金 表面处理: 阳极氧化



100x100x15

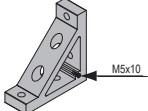

P Fastening Set	W Fastening Set	J Fastening Set	M5 Machining Code
 M5x10 Bolt zinc plated  M5 Washer zinc plated	 M8x30 Bolt zinc plated  M8 Spring Washer zinc plated  M8 Washer zinc plated  M8 T Nut nickel plated	 M8x25 Bolt zinc plated  M8 Spring Washer zinc plated  M8 Washer zinc plated  M8 T Nut nickel plated	 M5x10

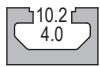
Application 应用	Description 产品描述	D (mm)	W (mm)	PG (mm)	Fastening Set 紧固组件	Machining Code 加工代码	Mass 重量 (g)	Part No. 订购编号
PG40 120mm 	100-40-120 (pcs/单个供货)	9	110	40			824	3.31.100.40.120
	100-40-120 (set/成套供货)				6xW+6xJ		1136	3.31.100.40.120.ST
	100-40-120 (M5/加工供货)					M5	824	3.31.100.40.120.M5
	100-40-120 (M5 set/成套加工供货)				6xW+6xJ+1xP	M5	1138	3.31.100.40.120.M5.ST

Connecting Elements
 连接件

Angle Profile Bracket

挤压角铝



Material: aluminium, anodized

材质: 铝合金 表面处理: 阳极氧化

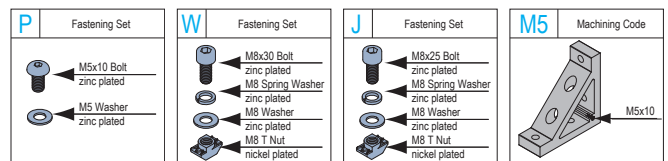
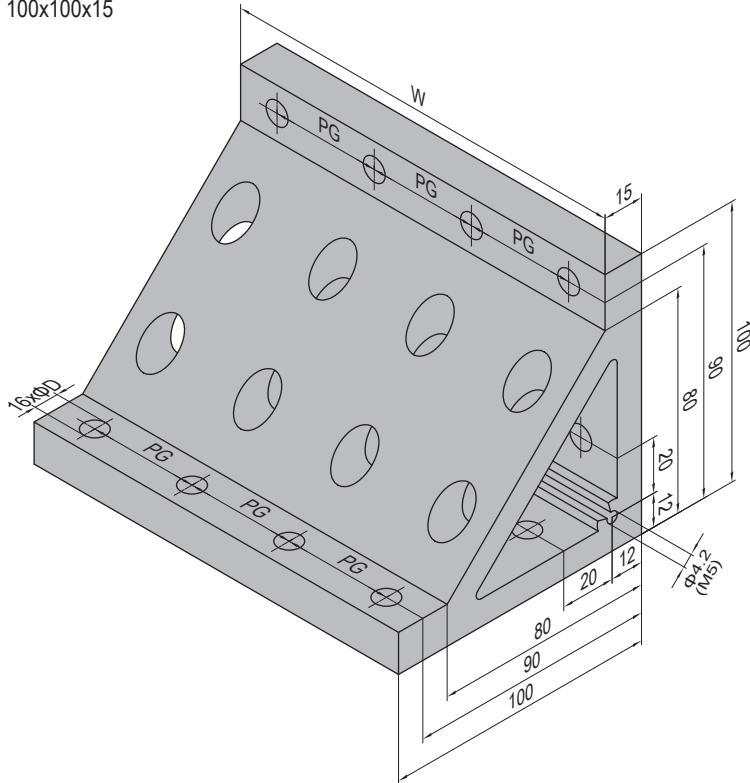

100x100x15



Application 应用	Description 产品描述	D (mm)	W (mm)	PG (mm)	Fastening Set 紧固组件	Machining Code 加工代码	Mass 重量 (g)	Part No. 订购编号
PG40 160mm 	100-40-160 (pcs/单个供货)	9	150	40			1127	3.31.100.40.160
	100-40-160 (set/成套供货)				8xW+8xJ		1543	3.31.100.40.160.ST
	100-40-160 (M5/加工供货)					M5	1127	3.31.100.40.160.M5
	100-40-160 (M5 set/成套加工供货)				8xW+8xJ+1xP	M5	1545	3.31.100.40.160.M5.ST
PG45 180mm 	100-45-180 (pcs/单个供货)	9	170	45			1293	3.31.100.45.180
	100-45-180 (set/成套供货)				8xW+8xJ		1709	3.31.100.45.180.ST
	100-45-180 (M5/加工供货)					M5	1293	3.31.100.45.180.M5
	100-45-180 (M5 set/成套加工供货)				8xW+8xJ+1xP	M5	1711	3.31.100.45.180.M5.ST



Connecting Elements
连接件

Angle Profile Bracket

挤压角铝

Material: aluminium, anodized

材质: 铝合金 表面处理: 阳极氧化



100x100x15

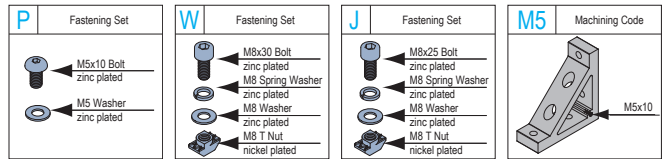
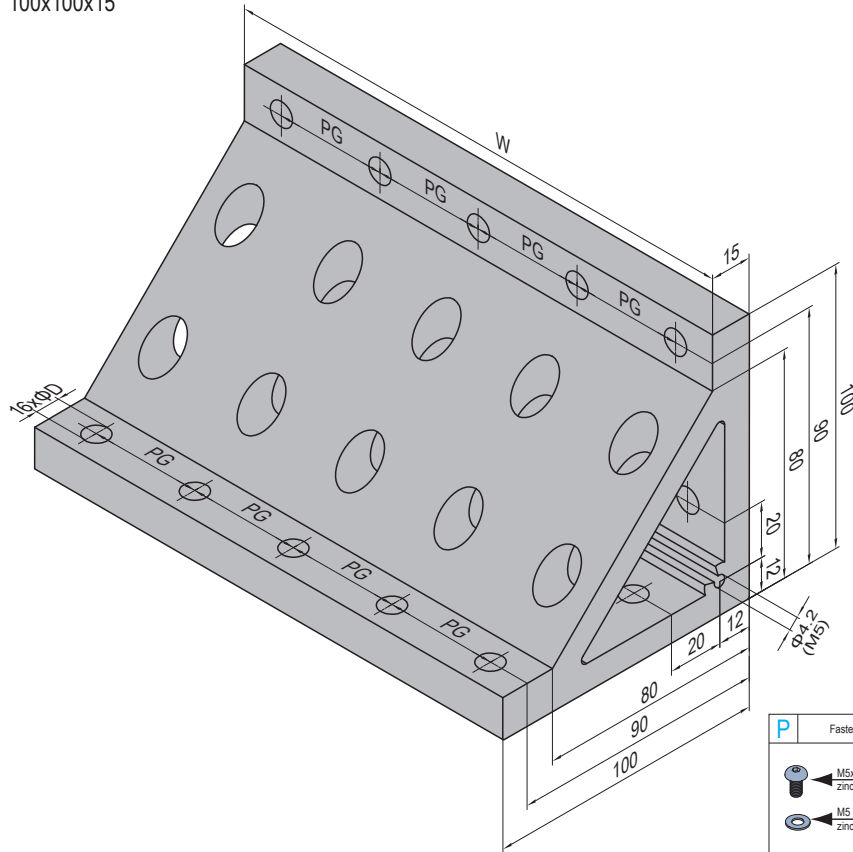

Application 应用	Description 产品描述	D (mm)	W (mm)	PG (mm)	Fastening Set 紧固组件	Machining Code 加工代码	Mass 重量 (g)	Part No. 订购编号
PG40 200mm 	100-40-200 (pcs/单个供货)	9	190	40			1477	3.31.100.40.200
	100-40-200 (set/成套供货)				10xW+10xJ		1893	3.31.100.40.200.ST
	100-40-200 (M5/加工供货)					M5	1477	3.31.100.40.200.M5
	100-40-200 (M5 set/成套加工供货)				10xW+10xJ+1xP	M5	1895	3.31.100.40.200.M5.ST



Connecting Elements
连接件

Inner Bracket (with top thread)

槽内直角件(含顶丝)

Inner bracket is with low cost and high efficiency, widely used for the assembly of door, window and protection frame.

槽内直角件因其低成本、实用高效, 被广泛地应用于门窗、防护框架的组装。

Material: bracket-diecast zinc top thread-zinc plated steel

材质: 直角件-锌合金 顶丝-碳钢镀锌

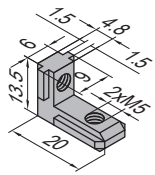

M5x6

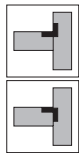

Inner Bracket/槽内直角件-6-A
3.41.06A

Inner Bracket/槽内直角件-6-B
3.41.06B

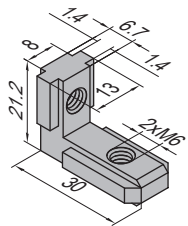

M6x8

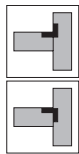

Inner Bracket/槽内直角件-8-A
3.41.08A

Inner Bracket/槽内直角件-8-B
3.41.08B

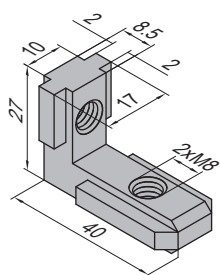

M8x10

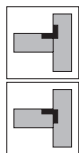

Inner Bracket/槽内直角件-10-A
3.41.10A

Inner Bracket/槽内直角件-10-B
3.41.10B

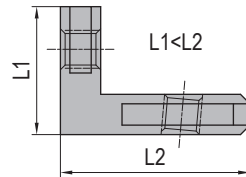
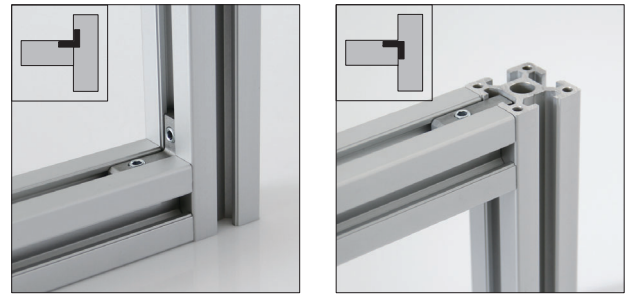

Type A

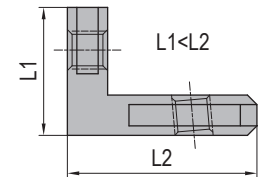

Type B

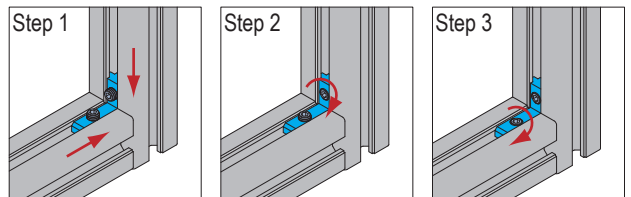

Step 1
set parts in position
置入槽口

Step 2
tighten L1 top thread
锁紧L1顶丝

Step 3
tighten L2 top thread
锁紧L2顶丝

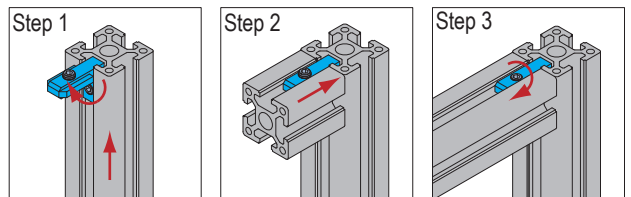

Description 产品描述	Mass 重量 (g/pcs)	Part No. 订购编号
Inner Bracket-6-A (with top thread) 槽内直角件-6-A(含顶丝)	6	3.41.06A
Inner Bracket-6-B (with top thread) 槽内直角件-6-B(含顶丝)		3.41.06B
Inner Bracket-8-A (with top thread) 槽内直角件 8-A(含顶丝)	18	3.41.08A
Inner Bracket-8-B (with top thread) 槽内直角件-8-B(含顶丝)		3.41.08B
Inner Bracket-10-A (with top thread) 槽内直角件-10-A(含顶丝)	36	3.41.10A
Inner Bracket-10-B (with top thread) 槽内直角件-10-B(含顶丝)		3.41.10B

Connecting Elements
连接件

Linear Bar Connector (with top thread)
槽内直线件 (含顶丝)
Material: zinc plated steel
材质: 碳钢镀锌

Linear Bar Connector-6
槽内直线件-6

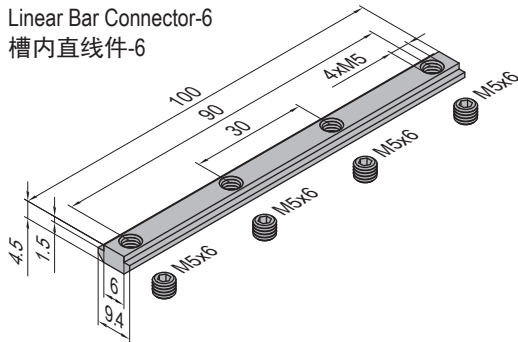

Linear Bar Connector-8
槽内直线件-8

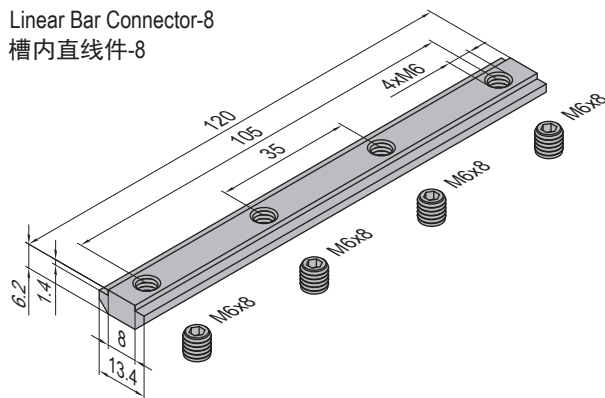

Linear Bar Connector-10
槽内直线件-10

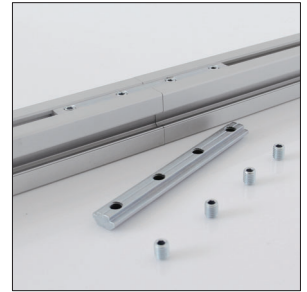
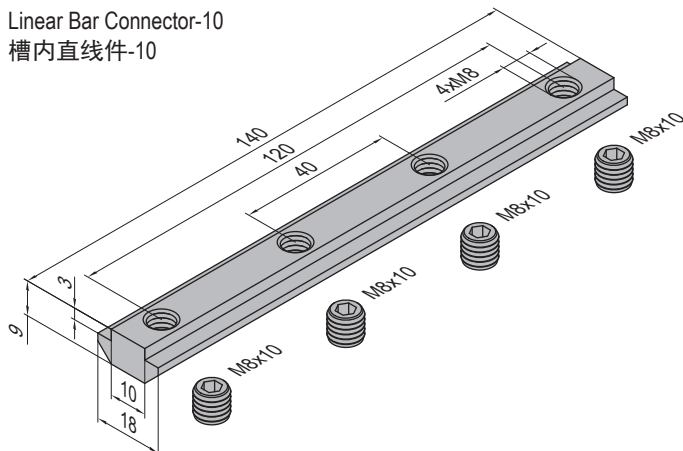

Reliability 强度:	★★★★★
Efficiency 安装效率:	★★★★★
Economical 经济:	★★★★★

Description 产品描述	Mass 重量 (g/pcs)	Part No. 订购编号
Linear Bar Connector-6 (with top thread) 槽内直线件-6 (含顶丝)	27	3.51.06
Linear Bar Connector-8 (with top thread) 槽内直线件-8 (含顶丝)	65	3.51.08
Linear Bar Connector-10 (with top thread) 槽内直线件-10 (含顶丝)	132	3.51.10

Connecting Elements
连接件

Linear Bar Connector (with top thread)
槽内直线件 (含顶丝)
Material: zinc plated steel
材质: 碳钢镀锌

Linear Bar Connector-8
槽内直线件-8

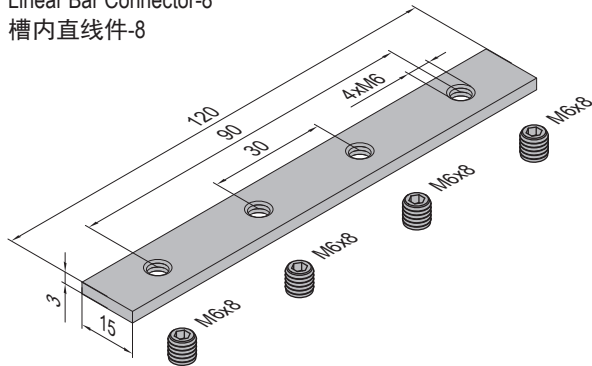

Reliability 强度:	★★★★
Efficiency 安装效率:	★★★★
Economical 经济:	★★★★

Description 产品描述	Mass 重量 (g/pcs)	Part No. 订购编号
Linear Bar Connector-8 (with top thread) 槽内直线件-8 (含顶丝)	40	3.52.08
Linear Bar Connector-10 (with top thread) 槽内直线件-10 (含顶丝)	74	3.52.10

Linear Bar Connector-10
槽内直线件-10

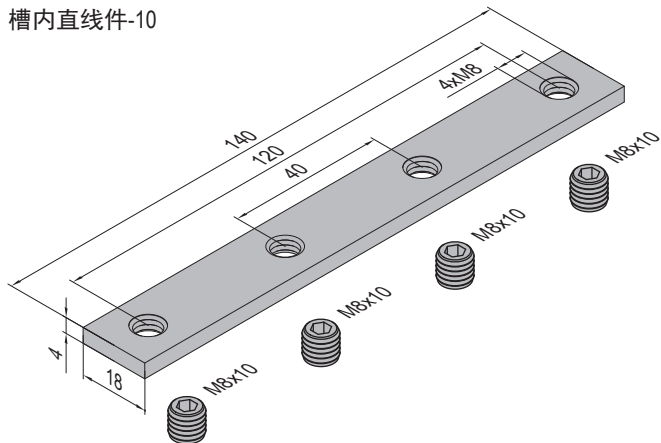

Connecting Elements
连接件

Joining Plate
连接板

Material: zinc plated steel
材质: 碳钢镀锌



PG30-3030-01
30系列-3030-01

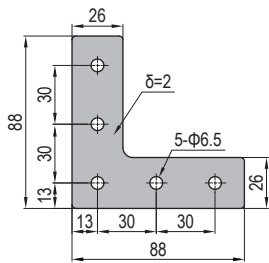

PG30-3030-02
30系列-3030-02

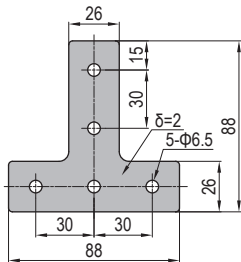

PG30-3030-03
30系列-3030-03

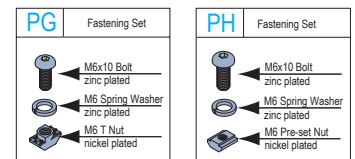
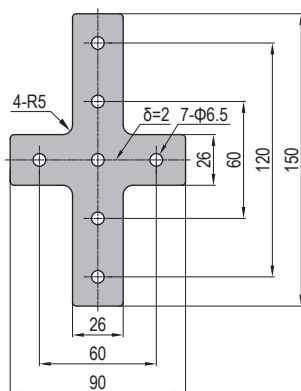

Description 产品描述	Fastening Set 紧固组件	Mass 重量 (g)	Part No. 订购编号
PG30-3030-01 (pcs) 30系列-3030-01 (单个供货)		58	3.53.30.3030.01
PG30-3030-01 (set A) 30系列-3030-01 (成套供货A)	5xPG	92	3.53.30.3030.01.STA
PG30-3030-01 (set B) 30系列-3030-01 (成套供货B)	5xPH	112	3.53.30.3030.01.STB
PG30-3030-02 (pcs) 30系列-3030-02 (单个供货)		58	3.53.30.3030.02
PG30-3030-02 (set A) 30系列-3030-02 (成套供货A)	5xPG	92	3.53.30.3030.02.STA
PG30-3030-02 (set B) 30系列-3030-02 (成套供货B)	5xPH	112	3.53.30.3030.02.STB
PG30-3030-03 (pcs) 30系列-3030-03 (单个供货)		83	3.53.30.3030.03
PG30-3030-03 (set A) 30系列-3030-03 (成套供货A)	7xPG	130	3.53.30.3030.03.STA
PG30-3030-03 (set B) 30系列-3030-03 (成套供货B)	7xPH	158	3.53.30.3030.03.STB

Connecting Elements
连接件

Joining Plate

连接板

Material: zinc plated steel

材质: 碳钢镀锌



PG40-4040-01
40系列-4040-01

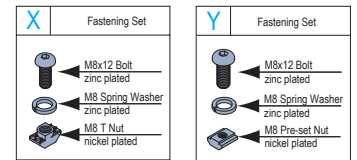
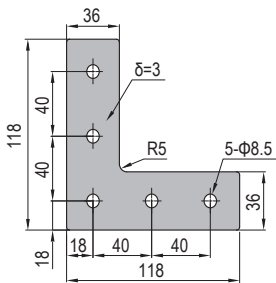

PG40-4040-02
40系列-4040-02

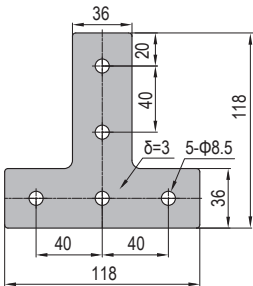

PG40-4040-03
40系列-4040-03

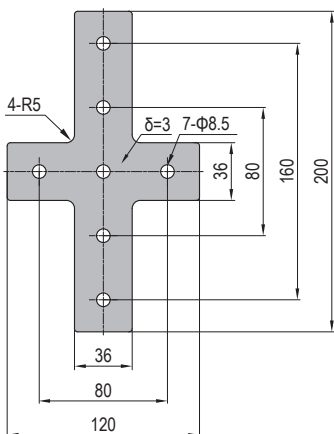

Description 产品描述	Fastening Set 紧固组件	Mass 重量 (g)	Part No. 订购编号
PG40-4040-01 (pcs) 40系列-4040-01 (单个供货)		147	3.53.40.4040.01
PG40-4040-01 (set X) 40系列-4040-01 (成套供货X)	5xX	217	3.53.40.4040.01.STX
PG40-4040-01 (set Y) 40系列-4040-01 (成套供货Y)	5xY	257	3.53.40.4040.01.STY
PG40-4040-02 (pcs) 40系列-4040-02 (单个供货)		149	3.53.40.4040.02
PG40-4040-02 (set X) 40系列-4040-02 (成套供货X)	5xX	219	3.53.40.4040.02.STX
PG40-4040-02 (set Y) 40系列-4040-02 (成套供货Y)	5xY	259	3.53.40.4040.02.STY
PG40-4040-03 (pcs) 40系列-4040-03 (单个供货)		230	3.53.40.4040.03
PG40-4040-03 (set X) 40系列-4040-03 (成套供货X)	7xX	328	3.53.40.4040.03.STX
PG40-4040-03 (set Y) 40系列-4040-03 (成套供货Y)	7xY	384	3.53.40.4040.03.STY

Connecting Elements
连接件

Joining Plate
连接板

Material: zinc plated steel

材质: 碳钢镀锌

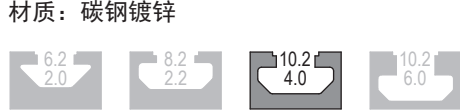

PG40-4040-04
40系列-4040-04

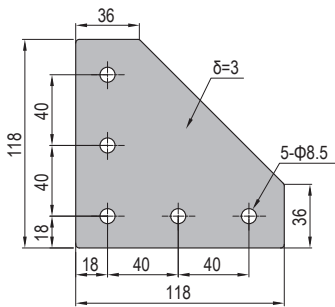



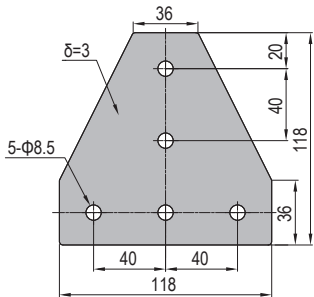

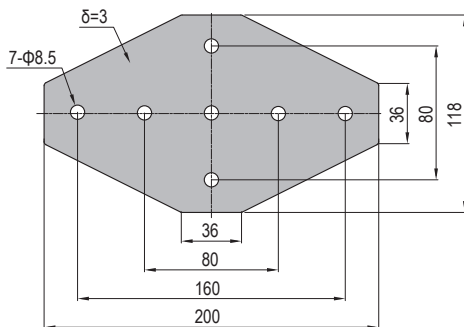

PG40-4040-05
40系列-4040-05



PG40-4040-06
40系列-4040-06



X	Fastening Set	Y	Fastening Set
	M8x12 Bolt zinc plated		M8x12 Bolt zinc plated
	M8 Spring Washer zinc plated		M8 Spring Washer zinc plated
	M8 T Nut nickel plated		M8 Pre-set Nut nickel plated

Description 产品描述	Fastening Set 紧固组件	Mass 重量 (g)	Part No. 订购编号
PG40-4040-04 (pcs) 40系列-4040-04 (单个供货)		222	3.53.40.4040.04
PG40-4040-04 (set X) 40系列-4040-04 (成套供货X)	5xX	292	3.53.40.4040.04.STX
PG40-4040-04 (set Y) 40系列-4040-04 (成套供货Y)	5xY	332	3.53.40.4040.04.STY
PG40-4040-05 (pcs) 40系列-4040-05 (单个供货)		220	3.53.40.4040.05
PG40-4040-05 (set X) 40系列-4040-05 (成套供货X)	5xX	290	3.53.40.4040.05.STX
PG40-4040-05 (set Y) 40系列-4040-05 (成套供货Y)	5xY	330	3.53.40.4040.05.STY
PG40-4040-06 (pcs) 40系列-4040-06 (单个供货)		355	3.53.40.4040.06
PG40-4040-06 (set X) 40系列-4040-06 (成套供货X)	7xX	453	3.53.40.4040.06.STX
PG40-4040-06 (set Y) 40系列-4040-06 (成套供货Y)	7xY	510	3.53.40.4040.06.STY

Connecting Elements
连接件

Joining Plate

连接板

Material: zinc plated steel

材质: 碳钢镀锌



PG40-4080-01
40系列-4080-01

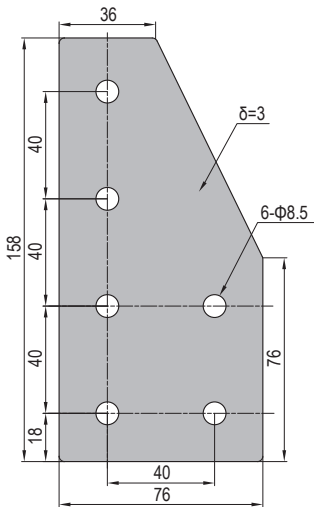

PG40-4080-02
40系列-4080-02

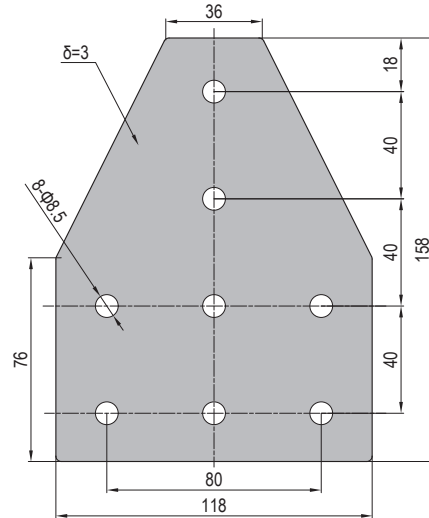

PG40-4080-03
40系列-4080-03

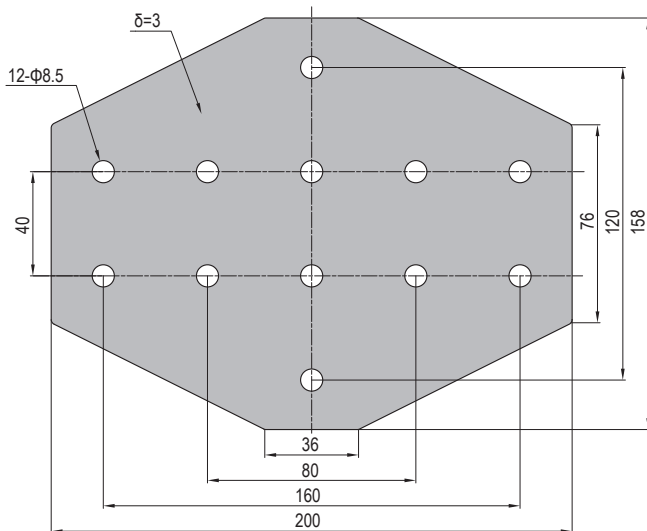

X	Fastening Set	Y	Fastening Set
	M8x12 Bolt zinc plated		M8x12 Bolt zinc plated
	M8 Spring Washer zinc plated		M8 Spring Washer zinc plated
	M8 T Nut nickel plated		M8 Pre-set Nut nickel plated

Description 产品描述	Fastening Set 紧固组件	Mass 重量 (g)	Part No. 订购编号
PG40-4080-01 (pcs) 40系列-4080-01 (单个供货)		222	3.53.40.4080.01
PG40-4080-01 (set X) 40系列-4080-01 (成套供货X)	6xX	306	3.53.40.4080.01.STX
PG40-4080-01 (set Y) 40系列-4080-01 (成套供货Y)	6xY	354	3.53.40.4080.01.STY
PG40-4080-02 (pcs) 40系列-4080-02 (单个供货)		347	3.53.40.4080.02
PG40-4080-02 (set X) 40系列-4080-02 (成套供货X)	8xX	459	3.53.40.4080.02.STX
PG40-4080-02 (set Y) 40系列-4080-02 (成套供货Y)	8xY	523	3.53.40.4080.02.STY
PG40-4080-03 (pcs) 40系列-4080-03 (单个供货)		523	3.53.40.4080.03
PG40-4080-03 (set X) 40系列-4080-03 (成套供货X)	12xX	691	3.53.40.4080.03.STX
PG40-4080-03 (set Y) 40系列-4080-03 (成套供货Y)	12xY	787	3.53.40.4080.03.STY



Connecting Elements
连接件

Joining Plate
连接板

Material: zinc plated steel
材质: 碳钢镀锌



PG40-8080-01
40系列-8080-01

PG40-8080-02
40系列-8080-02

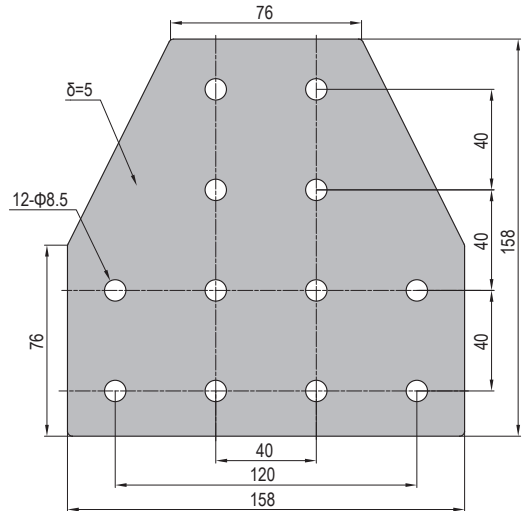
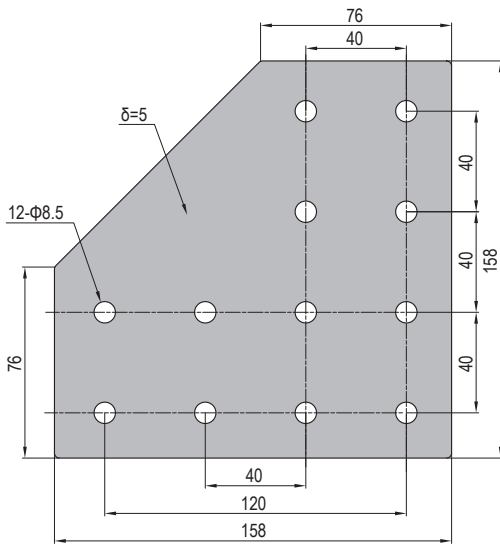

PG40-8080-03
40系列-8080-03

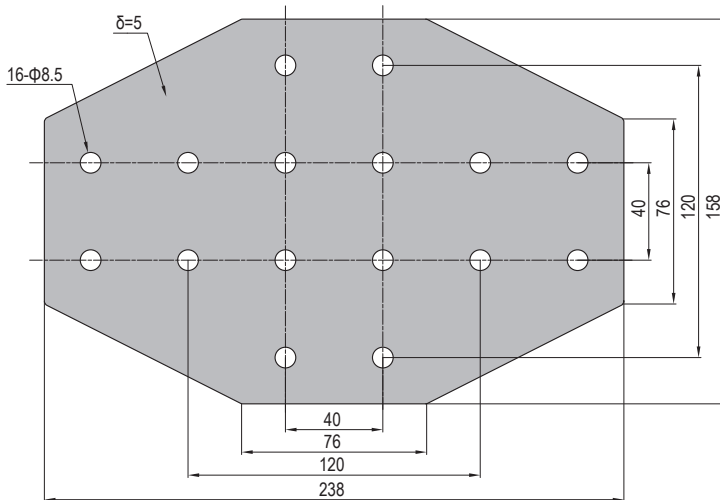

I	Fastening Set	O	Fastening Set
	M8x16 Bolt zinc plated		M8x16 Bolt zinc plated
	M8 Spring Washer zinc plated		M8 Spring Washer zinc plated
	M8T Nut nickel plated		M8 Pre-set Nut nickel plated

Description 产品描述	Fastening Set 紧固组件	Mass 重量 (g)	Part No. 订购编号
PG40-8080-01 (pcs) 40系列-8080-01 (单个供货)		730	3.53.40.8080.01
PG40-8080-01 (set I) 40系列-8080-01 (成套供货I)	12xI	910	3.53.40.8080.01.STI
PG40-8080-01 (set O) 40系列-8080-01 (成套供货O)	12xO	1006	3.53.40.8080.01.STO
PG40-8080-02 (pcs) 40系列-8080-02 (单个供货)		731	3.53.40.8080.02
PG40-8080-02 (set I) 40系列-8080-02 (成套供货I)	12xI	911	3.53.40.8080.02.STI
PG40-8080-02 (set O) 40系列-8080-02 (成套供货O)	12xO	1007	3.53.40.8080.02.STO
PG40-8080-03 (pcs) 40系列-8080-03 (单个供货)		1043	3.53.40.8080.03
PG40-8080-03 (set I) 40系列-8080-03 (成套供货I)	16xI	1283	3.53.40.8080.03.STI
PG40-8080-03 (set O) 40系列-8080-03 (成套供货O)	16xO	1411	3.53.40.8080.03.STO

Connecting Elements
连接件

Joining Plate

连接板

Material: zinc plated steel

材质: 碳钢镀锌



PG45-4545-01
45系列-4545-01

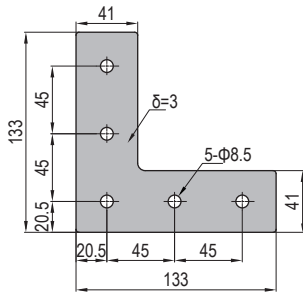



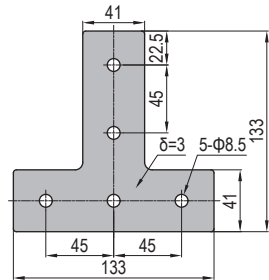

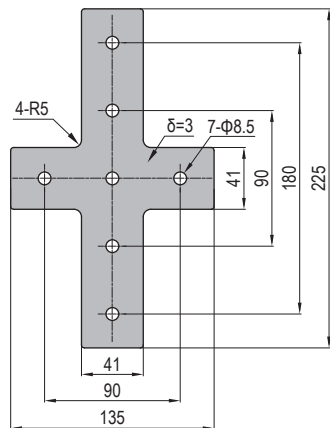

PG45-4545-02
45系列-4545-02



PG45-4545-03
45系列-4545-03



I	Fastening Set	O	Fastening Set
	M8x16 Bolt zinc plated		M8x16 Bolt zinc plated
	M8 Spring Washer zinc plated		M8 Spring Washer zinc plated
	M8T Nut nickel plated		M8 Pre-set Nut nickel plated

Description 产品描述	Fastening Set 紧固组件	Mass 重量 (g)	Part No. 订购编号
PG45-4545-01 (pcs) 45系列-4545-01 (单个供货)		209	3.53.45.4545.01
PG45-4545-01 (set I) 45系列-4545-01 (成套供货I)	5xI	288	3.53.45.4545.01.STI
PG45-4545-01 (set O) 45系列-4545-01 (成套供货O)	5xO	328	3.53.45.4545.01.STO
PG45-4545-02 (pcs) 45系列-4545-02 (单个供货)		209	3.53.45.4545.02
PG45-4545-02 (set I) 45系列-4545-02 (成套供货I)	5xI	288	3.53.45.4545.02.STI
PG45-4545-02 (set O) 45系列-4545-02 (成套供货O)	5xO	328	3.53.45.4545.02.STO
PG45-4545-03 (pcs) 45系列-4545-03 (单个供货)		297	3.53.45.4545.03
PG45-4545-03 (set I) 45系列-4545-03 (成套供货I)	7xI	408	3.53.45.4545.03.STI
PG45-4545-03 (set O) 45系列-4545-03 (成套供货O)	7xO	464	3.53.45.4545.03.STO

Connecting Elements
连接件

Butt Connector
内置连接件



Butt Connector is used for profile affiliating connection and widely used in clean room.
内置连接件主要用于型材附属连接，广泛应用于洁净室。
Material: zinc alloy, nickel plated
材质：锌合金 表面处理：镀镍



Butt Connector-8
内置连接件-8

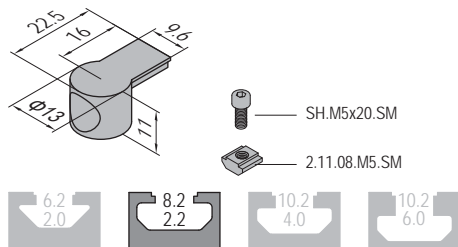

Butt Connector-10
内置连接件-10

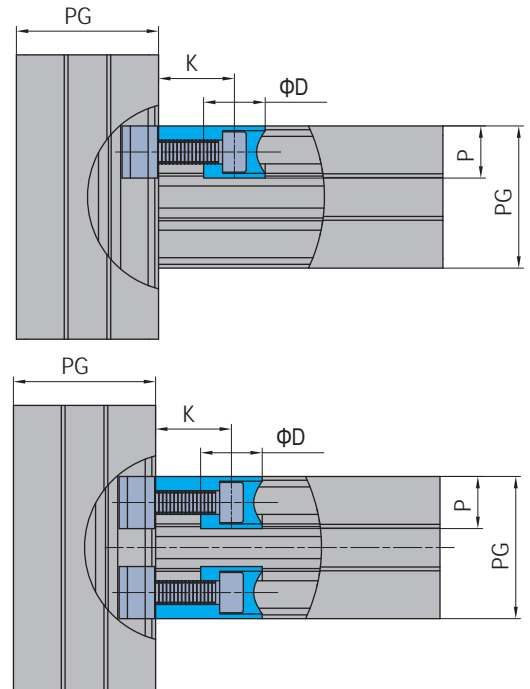
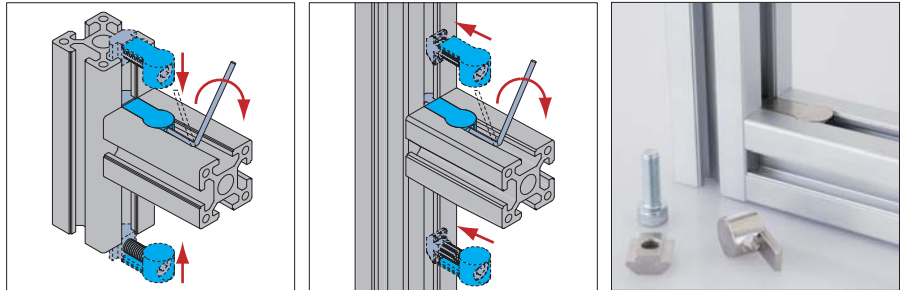
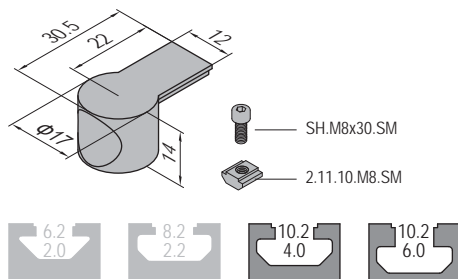

PG	Fastening Set	CE	Fastening Set	Q	Fastening Set	S	Fastening Set
	M5x20 Bolt zinc plated		M8x30 Bolt zinc plated		M5x20 Bolt zinc plated		M8x30 Bolt zinc plated
	M5 T Nut nickel plated		M8 T Nut nickel plated		M5 Pre-set Nut nickel plated		M8 Pre-set Nut nickel plated

Description 产品描述	PG 型材系列	K (mm)	D (mm)	P (mm)	Fastening Set 紧固组件	Mass 重量 (g)	Part No. 订购编号
Butt Connector-8 (pcs) 内置连接件-8 (单个供货)	PG30	16	13	11		9	3.61.08
Butt Connector-8 (set A) 内置连接件-8 (成套供货A)					1xQ	20	3.61.08.STA
Butt Connector-8 (set B) 内置连接件-8 (成套供货B)					1xPG	18	3.61.08.STB
Butt Connector-10 (pcs) 内置连接件-10 (单个供货)	PG40/PG45/PG50/PG60	22	17	14		15	3.61.10
Butt Connector-10 (set A) 内置连接件-10 (成套供货A)					1xS	43	3.61.10.STA
Butt Connector-10 (set B) 内置连接件-10 (成套供货B)					1xCE	39	3.61.10.STB



Connecting Elements
连接件

End Connector
端连接件

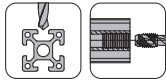

End connector is also called butterfly button connector due to its shape which can hide itself completely in aluminum profile, so it is widely used for frame structures in clean room.

端连接件因其形状又叫蝴蝶扣。此连接可以完全隐藏在型材之中，所以广泛地应用在洁净室的框架结构中。

Material: nickel plated steel
材质：碳钢镀镍



End Connector-8
端连接件-8

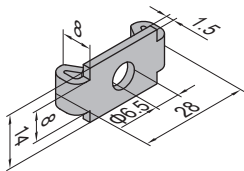

End Connector-10
端连接件-10

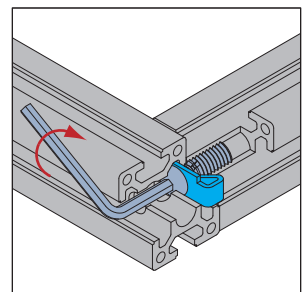
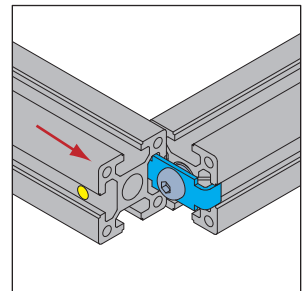
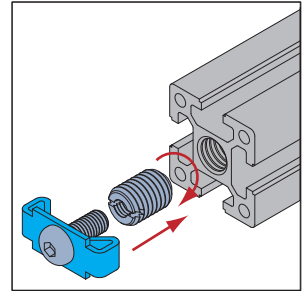
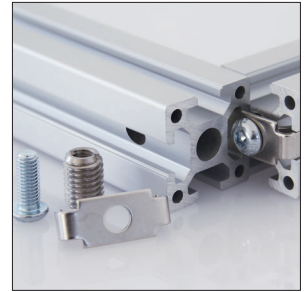
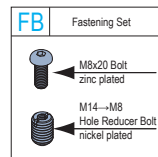
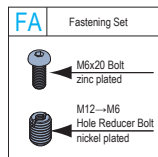
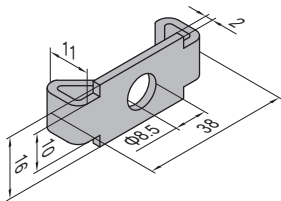

Description 产品描述	PG 型材系列	Fastening Set 紧固组件	Mass 重量 (g)	Part No. 订购编号
End Connector-8 (pcs) 端连接件-8 (单个供货)	PG30		7	3.71.30
End Connector-8 (set) 端连接件-8 (成套供货)		1xFA	23	3.71.30.ST
End Connector-10 (pcs) 端连接件-10 (单个供货)	PG40		13	3.71.40
End Connector-10 (set) 端连接件-10 (成套供货)		1xFB	38	3.71.40.ST

Connecting Elements
连接件

Screw Connector
大螺栓

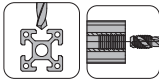

A simple and economic way to replace end connector with more connection reliability.

大螺栓的连接方式更简单便捷。

Material: nickel plated steel

材质: 碳钢镀镍

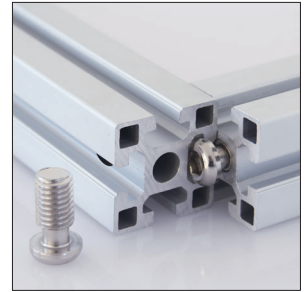

Screw Connector-6
大螺栓-6

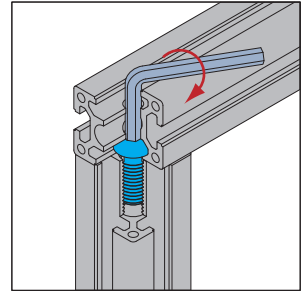
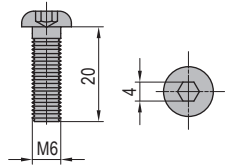

Screw Connector-8
大螺栓-8

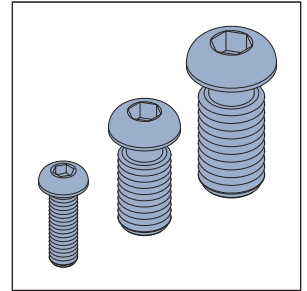
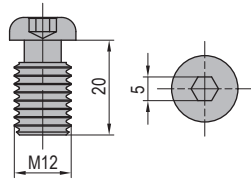

Screw Connector-10
大螺栓-10

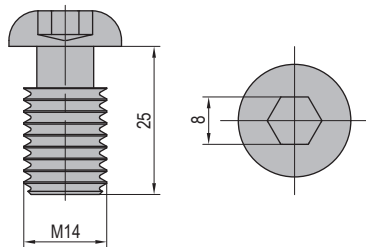

Description 产品描述	Mass 重量 (g)	Part No. 订购编号
Screw Connector-6 大螺栓-6	7	3.81.06
Screw Connector-8 大螺栓-8	17	3.81.08
Screw Connector-10 大螺栓-10	31	3.81.10

Connecting Elements
连接件

Cubic Connector
三维连接件

Material: Connector-diecast aluminum Cap-black ABS
材质: 三维连接件-压铸铝合金 端盖-ABS 端盖颜色: 端盖-黑色



Cubic Connector-4545-2
三维连接件-4545-2

Cubic Connector-4545-3
三维连接件-4545-3

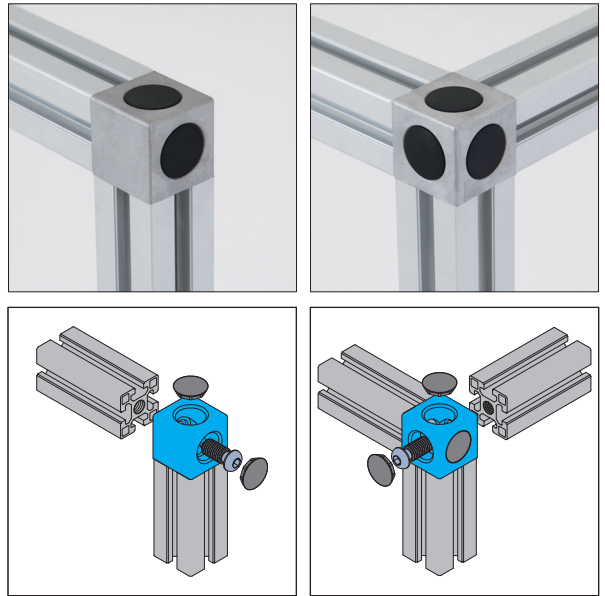
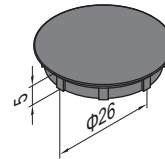
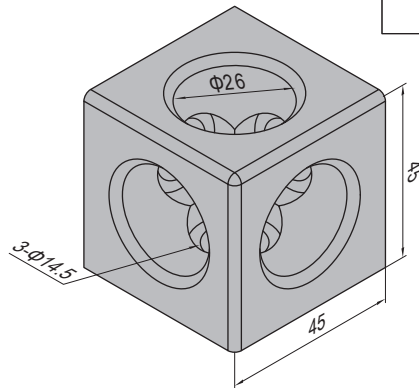
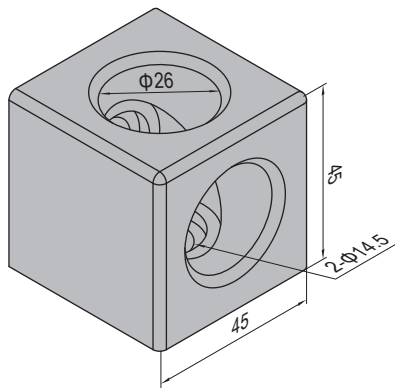

Description 产品描述	Fastening Set 紧固组件	Cap 端盖 (pcs)	Mass 重量 (g)	Part No. 订购编号
Cubic Connector-4545-2 (pcs) 三维连接件-4545-2 (单个供货)		2	135	3.91.4545.02
Cubic Connector-4545-2 (set) 三维连接件-4545-2 (成套供货)	2x(M14x25)		201	3.91.4545.02.ST
Cubic Connector-4545-3 (pcs) 三维连接件-4545-3 (单个供货)		3	135	3.91.4545.03
Cubic Connector-4545-3 (set) 三维连接件-4545-3 (成套供货)	3x(M14x25)		234	3.91.4545.03.ST

Connecting Elements
连接件

Cubic Connector
三维角件



Material: Connector-diecast zinc Cap-black ABS

材质: 三维角件-锌合金 端盖-ABS 端盖颜色: 端盖-黑色

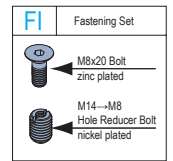
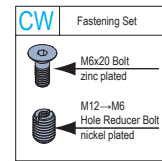
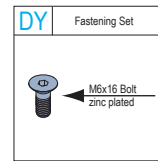
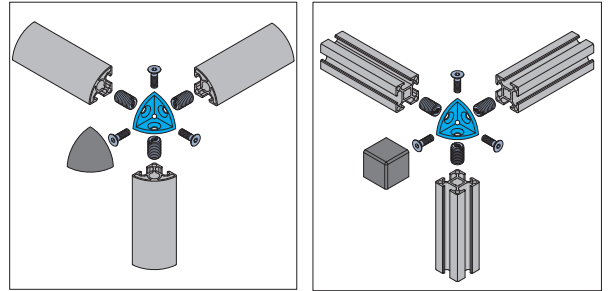
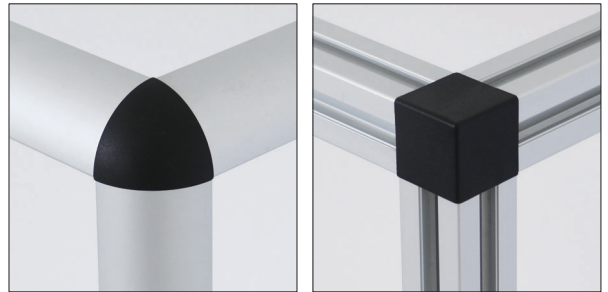
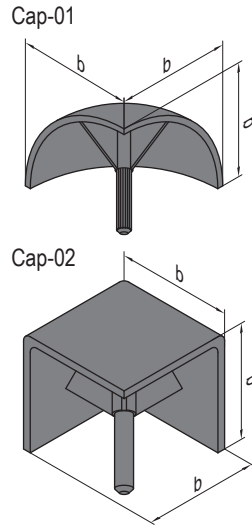
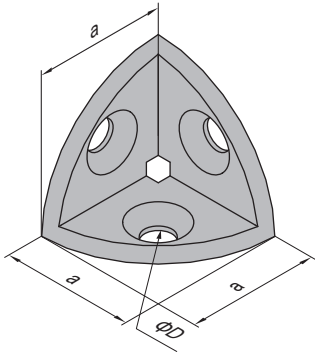
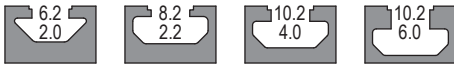

Description 产品描述	a	b	D	Fastening Set 紧固组件	Cap 端盖 (pcs)	Mass 重量 (g)	Part No. 订购编号
2020-01 (pcs)/单个供货	18.5	20	6.5		1	11	3.92.2020.01
2020-01 (set)/成套供货				3xDY		23	3.92.2020.01.ST
2020-02 (pcs)/单个供货						12	3.92.2020.02
2020-02 (set)/成套供货				3xDY		24	3.92.2020.02.ST
3030-01 (pcs)/单个供货	28	30	6.5		1	35	3.92.3030.01
3030-01 (set)/成套供货				3xCW		105	3.92.3030.01.ST
3030-02 (pcs)/单个供货						38	3.92.3030.02
3030-02 (set)/成套供货				3xCW		108	3.92.3030.02.ST
4040-01 (pcs)/单个供货	38	40	8.5		1	87	3.92.4040.01
4040-01 (set)/成套供货				3xFI		159	3.92.4040.01.ST
4040-02 (pcs)/单个供货						92	3.92.4040.02
4040-02 (set)/成套供货				3xFI		164	3.92.4040.02.ST
4545-01 (pcs)/单个供货	42	45	8.5		1	114	3.92.4545.01
4545-01 (set)/成套供货				3xFI		187	3.92.4545.01.ST
4545-02 (pcs)/单个供货						123	3.92.4545.02
4545-02 (set)/成套供货				3xFI		196	3.92.4545.02.ST



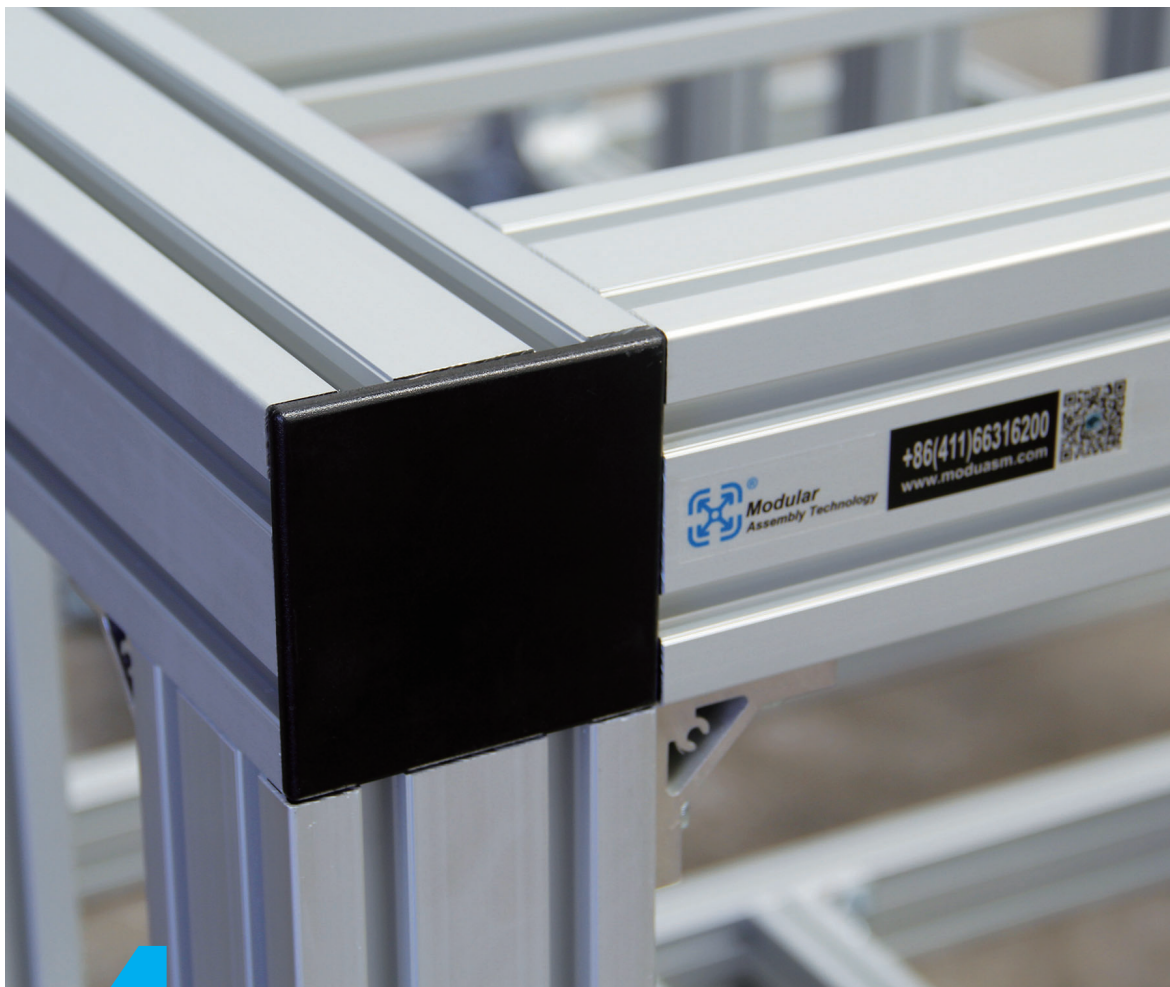

4.11-4.21

End Cap
端盖

T Slot Cover
T形槽扣条

4

Profile Accessories 型材附件

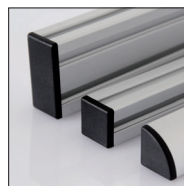

P. 4-02

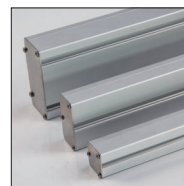

P. 4-04

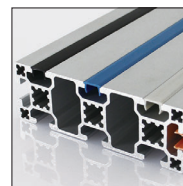

P. 4-05



Profile Accessories
 型材附件

 End Cap
 端盖

To prevent staff from any injury and improve profile end appearance.

端盖可以预防划伤, 使型材更美观。

Material and Color: black ABS

材质: ABS 颜色: 黑色

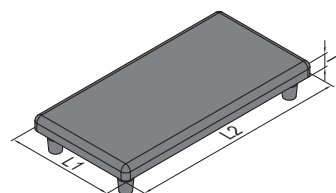
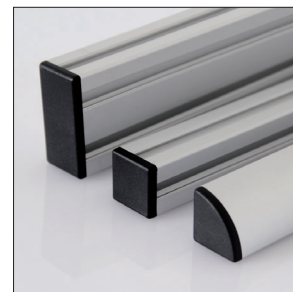

Description 产品描述	L1 (mm)	L2 (mm)	T (mm)	Mass 重量 (g)	Part No. 订购编号
End Cap-PG15-1515/端盖-15系列-1515	15	15	3	1	4.11.15.1515
End Cap-PG15-1530/端盖-15系列-1530	15	30	3	1.1	4.11.15.1530
End Cap-PG20-2020/端盖-20系列-2020	20	20	4	2	4.11.20.2020
End Cap-PG20-2040/端盖-20系列-2040	20	40	4	3	4.11.20.2040
End Cap-PG20-2060/端盖-20系列-2060	20	60	4	4	4.11.20.2060
End Cap-PG20-2080/端盖-20系列-2080	20	80	4	5	4.11.20.2080
End Cap-PG20-4040/端盖-20系列-4040	40	40	4	6	4.11.20.4040
End Cap-PG30-3030/端盖-30系列-3030	30	30	5	3	4.11.30.3030
End Cap-PG30-3060/端盖-30系列-3060	30	60	5	8	4.11.30.3060
End Cap-PG30-3090/端盖-30系列-3090	30	90	5	11	4.11.30.3090
End Cap-PG30-30120/端盖-30系列-30120	30	120	5	14	4.11.30.30120
End Cap-PG30-6060/端盖-30系列-6060	60	60	5	15	4.11.30.6060
End Cap-PG30-60120/端盖-30系列-60120	60	120	5	33	4.11.30.60120
End Cap-PG40-4040/端盖-40系列-4040	40	40	5	6	4.11.40.4040
End Cap-PG40-4060/端盖-40系列-4060	40	60	5	9	4.11.40.4060
End Cap-PG40-4080/端盖-40系列-4080	40	80	5	13	4.11.40.4080
End Cap-PG40-40120/端盖-40系列-40120	40	120	5	18	4.11.40.40120
End Cap-PG40-40160/端盖-40系列-40160	40	160	5	24	4.11.40.40160
End Cap-PG40-8080/端盖-40系列-8080	80	80	5	22	4.11.40.8080
End Cap-PG40-80120/端盖-40系列-80120	80	120	5	43	4.11.40.80120
End Cap-PG40-80160/端盖-40系列-80160	80	160	5	58	4.11.40.80160
End Cap-PG40-80200/端盖-40系列-80200	80	200	5	72	4.11.40.80200
End Cap-PG40-120120/端盖-40系列-120120	120	120	5	64	4.11.40.120120
End Cap-PG45-4545/端盖-45系列-4545	45	45	5	8	4.11.45.4545
End Cap-PG45-4560/端盖-45系列-4560	45	60	5	11	4.11.45.4560
End Cap-PG45-4590/端盖-45系列-4590	45	90	5	16	4.11.45.4590
End Cap-PG45-9090/端盖-45系列-9090	90	90	5	28	4.11.45.9090
End Cap-PG45-90180/端盖-45系列-90180	90	180	5	72	4.11.45.90180
End Cap-PG50-5050/端盖-50系列-5050	50	50	5	10	4.11.50.5050
End Cap-PG50-50100/端盖-50系列-50100	50	100	5	18	4.11.50.50100
End Cap-PG50-100100/端盖-50系列-100100	100	100	5	44	4.11.50.100100
End Cap-PG60-6060/端盖-60系列-6060	60	60	5	14	4.11.60.6060



Profile Accessories
型材附件

End Cap
端盖

To prevent staff from injury and improve profile end appearance.
端盖可以预防划伤, 使型材更美观。

Material and Color: black ABS
材质: ABS 颜色: 黑色

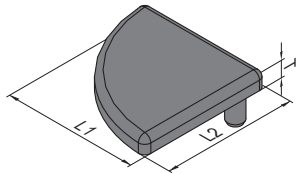
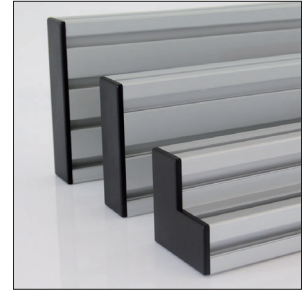

Description 产品描述	L1 (mm)	L2 (mm)	T (mm)	Mass 重量 (g)	Part No. 订购编号
End Cap-PG20-2020R/端盖-20系列-2020R	20	20	4	1	4.11.20.2020R
End Cap-PG30-3030R/端盖-30系列-3030R	30	30	5	3	4.11.30.3030R
End Cap-PG40-4040R/端盖-40系列-4040R	40	40	5	6	4.11.40.4040R
End Cap-PG45-4545R/端盖-45系列-4545R	45	45	5	7	4.11.45.4545R

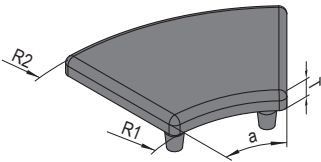

Description 产品描述	R1 (mm)	R2 (mm)	α	T (mm)	Mass 重量 (g)	Part No. 订购编号
End Cap-PG30-3030R45/端盖-30系列-3030R45	30	60	45°	5	4	4.11.30.3030R45 New
End Cap-PG40-4040R45/端盖-40系列-4040R45	40	80	45°	5	7	4.11.40.4040R45 New
End Cap-PG45-4545R45/端盖-45系列-4545R45	45	90	45°	5	9	4.11.45.4545R45 New

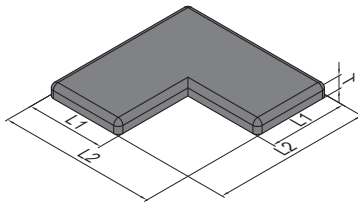

Description 产品描述	L1 (mm)	L2 (mm)	T (mm)	Mass 重量 (g)	Part No. 订购编号
End Cap-PG30-6060L/端盖-30系列-6060L	30	60	5	11	4.11.30.6060L
End Cap-PG40-8080L/端盖-40系列-8080L	40	80	5	17	4.11.40.8080L
End Cap-PG45-9090L/端盖-45系列-9090L	45	90	5	22	4.11.45.9090L

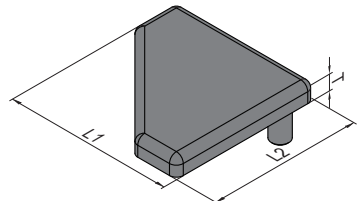

Description 产品描述	L1 (mm)	L2 (mm)	T (mm)	Mass 重量 (g)	Part No. 订购编号
End Cap-PG40-4040T/端盖-40系列-4040T	40	40	5	5.3	4.11.40.4040T

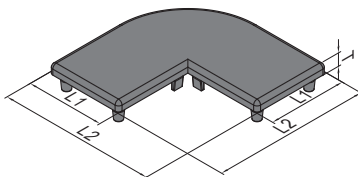

Description 产品描述	L1 (mm)	L2 (mm)	T (mm)	Mass 重量 (g)	Part No. 订购编号
End Cap-PG40-8080R/端盖-40系列-8080R	40	80	5	17	4.11.40.8080R New



Profile Accessories
型材附件

Conduit end cap
线槽端盖

To prevent staff from any injury and improve profile end appearance.
线槽端盖可以预防划伤，使型材更美观。

Material: stainless steel
材质：不锈钢

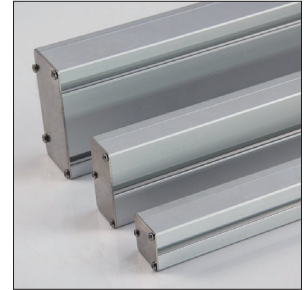

Conduit Cap-40x40
线槽端盖-40x40

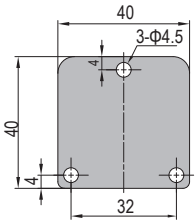

Conduit Cap-40x80
线槽端盖-40x80

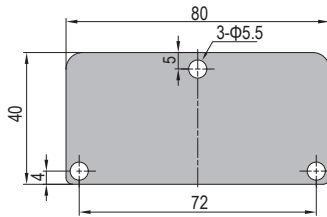

Conduit Cap-60x120
线槽端盖-60x120

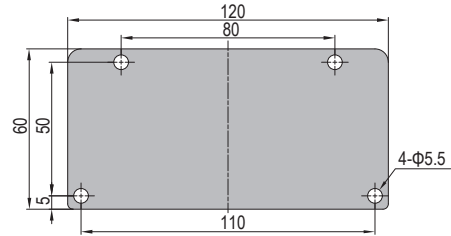

Conduit Cap-80x80
线槽端盖-80x80

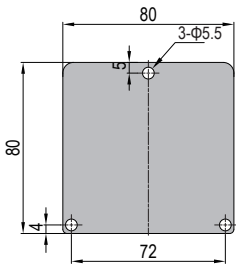

Conduit Cap-80x160
线槽端盖-80x160

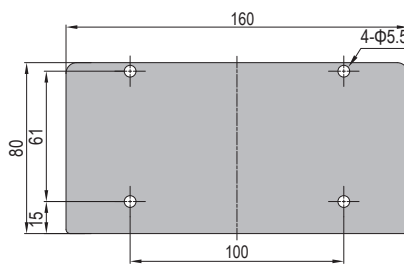

Conduit Cap-80x200
线槽端盖-80x200

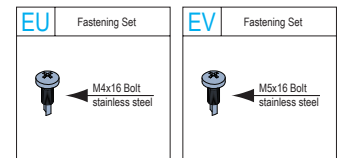
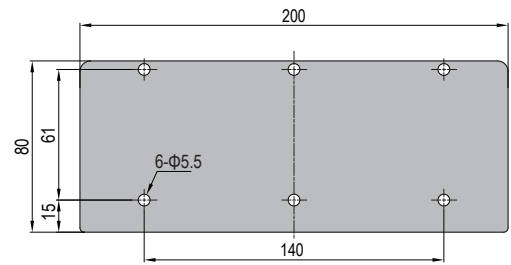

Description 产品描述	Thickness 厚度 T(mm)	Fastening Set 紧固组件	Mass 重量 (g)	Part No. 订购编号
Conduit Cap-40x40(pcs)/线槽端盖-40x40(单个供货)	2		24.5	4.14.40.4040
Conduit Cap-40x40(set)/线槽端盖-40x40(成套供货)		3xEU	29	4.14.40.4040.ST
Conduit Cap-40x80(pcs)/线槽端盖-40x80(单个供货)			50	4.14.40.4080
Conduit Cap-40x80(set)/线槽端盖-40x80(成套供货)		3xEV	59	4.14.40.4080.ST
Conduit Cap-60x120(pcs)/线槽端盖-60x120(单个供货)			113	4.14.40.60120
Conduit Cap-60x120(set)/线槽端盖-60x120(成套供货)		4xEV	125	4.14.40.60120.ST
Conduit Cap-80x80(pcs)/线槽端盖-80x80(单个供货)			99	4.14.40.8080
Conduit Cap-80x80(set)/线槽端盖-80x80(成套供货)		3xEV	108	4.14.40.8080.ST
Conduit Cap-80x160(pcs)/线槽端盖-80x160(单个供货)			203	4.14.40.80160
Conduit Cap-80x160(set)/线槽端盖-80x160(成套供货)		4xEV	215	4.14.40.80160.ST
Conduit Cap-80x200(pcs)/线槽端盖-80x200(单个供货)			247	4.14.40.80200
Conduit Cap-80x200(set)/线槽端盖-80x200(成套供货)		6xEV	265	4.14.40.80200.ST



Profile Accessories
型材附件
T Slot Cover
T形槽扣条

To prevent slot from contamination and improve structure appearance.

T形槽扣条用于防尘及美化框架结构外观。

Material and Color: PP black/blue/grey/orange

材质: PP 颜色: 黑色/蓝色/灰色/橘色

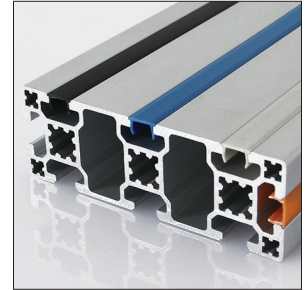
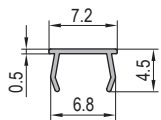
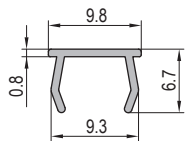
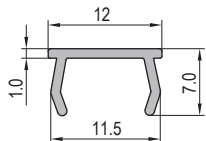
T Slot Cover-6
T形槽扣条-6

T Slot Cover-8
T形槽扣条-8

T Slot Cover-10
T形槽扣条-10

Description 产品描述	Color 颜色	Mass 重量 (g/m)	Delivery Length 供货长度	Part No. 订购编号
T Slot Cover-6 T形槽扣条-6	Black 黑色	11	2000mm/bar	4.21.06.BK
T Slot Cover-6 T形槽扣条-6	Blue 蓝色			4.21.06.BE
T Slot Cover-6 T形槽扣条-6	Grey 灰色			4.21.06.GY
T Slot Cover-6 T形槽扣条-6	Orange 橘色			4.21.06.SE
T Slot Cover-8 T形槽扣条-8	Black 黑色	22		4.21.08.BK
T Slot Cover-8 T形槽扣条-8	Blue 蓝色			4.21.08.BE
T Slot Cover-8 T形槽扣条-8	Grey 灰色			4.21.08.GY
T Slot Cover-8 T形槽扣条-8	Orange 橘色			4.21.08.SE
T Slot Cover-10 T形槽扣条-10	Black 黑色	38		4.21.10.BK
T Slot Cover-10 T形槽扣条-10	Blue 蓝色			4.21.10.BE
T Slot Cover-10 T形槽扣条-10	Grey 灰色			4.21.10.GY
T Slot Cover-10 T形槽扣条-10	Orange 橘色			4.21.10.SE

Note:

1. Cut to delivery length is not available, but 4000mm or Max. 5800 delivery length is available upon request.
不提供定尺切割服务, 但单根4000mm或5800mm可根据要求供货。
2. Customized color upon request is subject to 5000 meters minimum order quantities.
若需其他颜色, 最小起订量为5000米。



5.11-5.61

- Base Plate
隔断支脚
- Base Plate
型材底座
- Leveling Foot
支脚
- Mounting Plate
支脚连接板
- Castor Plate
脚轮连接板
- Castor
脚轮
- Base Angle
板支脚
- L Base
L形支脚
- Foot and Castor
Components
支脚万向轮组件
- Leveling Castor
水平调节轮

5

Floor Elements 地面组件



P. 5-02



P. 5-03

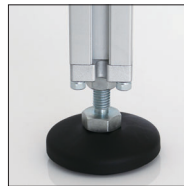

P. 5-04

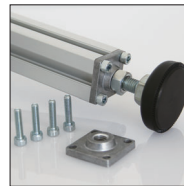

P. 5-07



P. 5-08

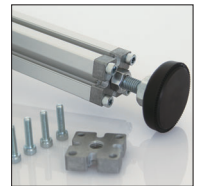

P. 5-10



P. 5-11



P. 5-14



P. 5-15



P. 5-16



P. 5-17



P. 5-18

Floor Elements
 地面组件





Base Plate
 隔断支脚

To support strut profile at the bottom. Expansion bolts chocked into floor can offer a high stability.
 隔断支脚用于防护单元之间型材的底部支撑，使用膨胀螺栓置入地下更能提高稳定性。
 Material and surface treatment: cast steel, black electrophoresis
 材质：铸钢 表面处理：黑色电泳

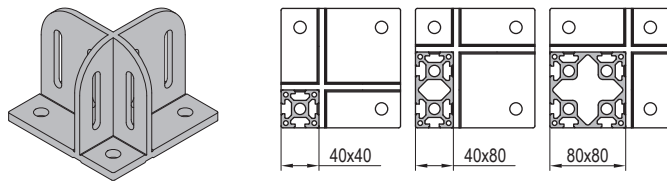
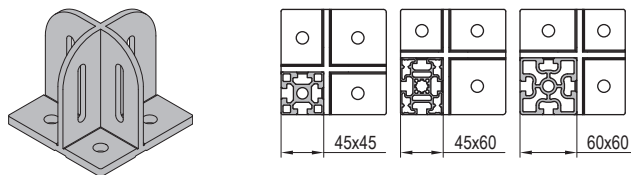
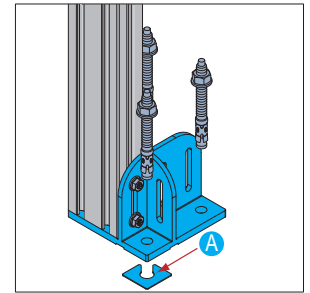
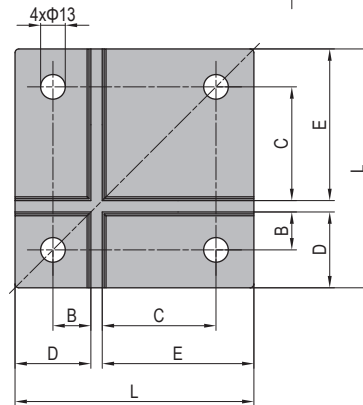
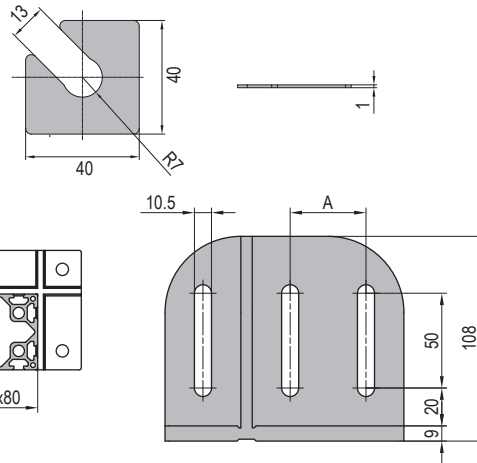
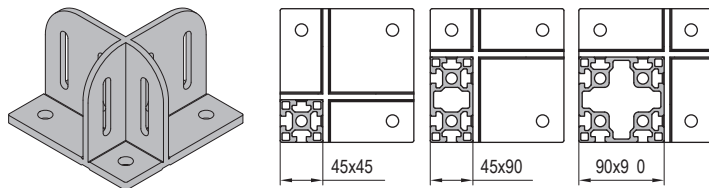
Base Plate Gasket
 隔断支脚垫片 **A**

To adjust the degree of vertical profile and uneven ground.
 隔断支脚垫片用于地面不平,调整型材与地面垂直度。

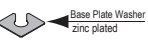
Base Plate-4080
 隔断支脚-4080

Base Plate-4560
 隔断支脚-4560

Base Plate-4590
 隔断支脚-4590

C	Fastening Set	AA	Fastening Set	AZ	Fastening Set
	M8 Flange Nut zinc plated		M10x100 expansion bolt zinc plated		Base Plate Washer zinc plated
	M8x25 T Bolt nickel plated				

Description 产品描述	L (mm)	A (mm)	B (mm)	C (mm)	D (mm)	E (mm)	Fastening Set 紧固组件	Mass 重量 (g)	Part No. 订购编号
Base Plate-4080 (pcs)/隔断支脚-4080 (单个供货)	126	40	20	60	40	80	2x AZ	1930	5.11.4080
Base Plate-4080 (set A)/隔断支脚-4080 (成套供货A)							4x C +3x AA +2x AZ	2240	5.11.4080.STA
Base Plate-4080 (set B)/隔断支脚-4080 (成套供货B)							6x C +3x AA +2x AZ	2290	5.11.4080.STB
Base Plate-4080 (set C)/隔断支脚-4080 (成套供货C)							8x C +3x AA +2x AZ	2340	5.11.4080.STC
Base Plate-4560 (pcs)/隔断支脚-4560 (单个供货)	111		22.5	30	45	60	2x AZ	1600	5.11.4560
Base Plate-4560 (set)/隔断支脚-4560 (成套供货)							4x C +3x AA +2x AZ	1910	5.11.4560.ST
Base Plate-4590 (pcs)/隔断支脚-4590 (单个供货)	141	45	22.5	67.5	45	90	2x AZ	2330	5.11.4590
Base Plate-4590 (set A)/隔断支脚-4590 (成套供货A)							4x C +3x AA +2x AZ	2640	5.11.4590.STA
Base Plate-4590 (set B)/隔断支脚-4590 (成套供货B)							6x C +3x AA +2x AZ	2690	5.11.4590.STB
Base Plate-4590 (set C)/隔断支脚-4590 (成套供货C)							8x C +3x AA +2x AZ	2740	5.11.4590.STC
Base Plate Gasket/隔断支脚垫片 A								9	5.11.01

Floor Elements
地面组件

Base Plate
型材底座

To support strut profile mounted on the floor or between the platforms. Expansion bolts chocked into the floor can offer a high stability.

型材底座用于型材与地面或平台之间的支撑，可用膨胀螺栓置入地下达到固定作用。

Material: diecast-aluminum

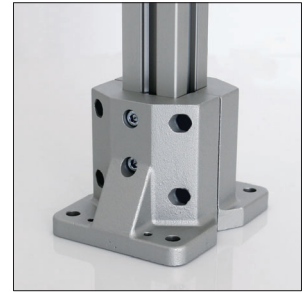

材质：压铸铝合金

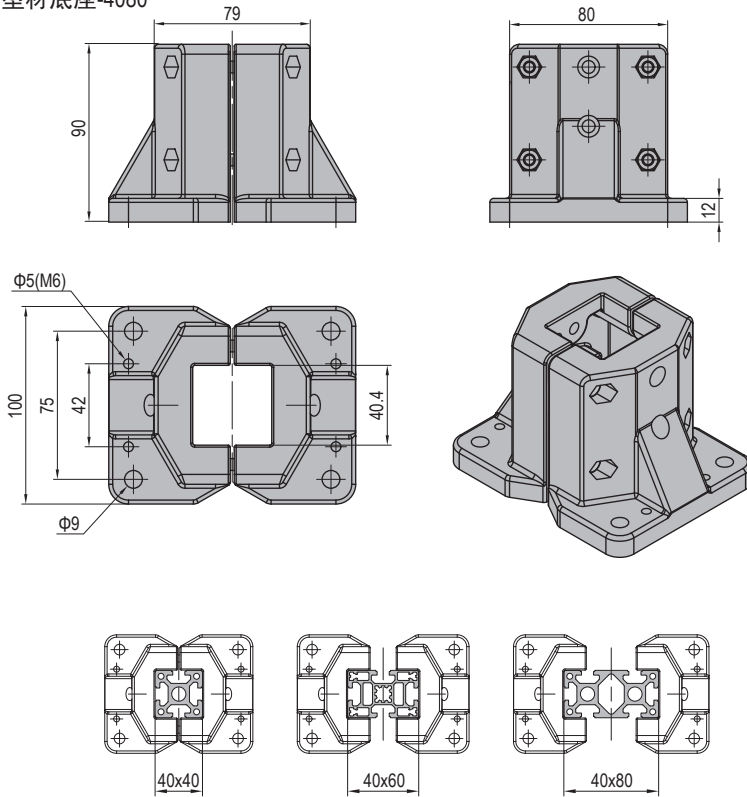

Base Plate-4080
型材底座-4080



Description 产品描述	Fastening Set 紧固组件	Mass 重量(g)	Part No. 订购编号
Base Plate-4080 (set) 型材底座-4080 (成套供货)	4xDT	975	5.12.40.ST

DT	Fastening Set
	M6x20 Bolt zinc plated
	M6 Spring Washer zinc plated
	M6 Pre-set Nut nickel plated

Floor Elements
地面组件
Leveling Foot-Pivot Foot
支脚-尼龙微调

To support structure where gradual height adjustment is needed, the pivot foot has a small swiveling angle to fit slightly uneven floor. The connection between the pivot base and the spindle can be released with a tool.

尼龙微调支脚用来支撑高度需要微调的框架结构, 调节角度较小, 适用于相对较平整的地面, 此支脚的牙杆和底盘可用工具拆分。

Material and Color: Base-black PA6 Spindle-zinc plated steel Pad-black rubber
 材质: 底盘-增强尼龙6 牙杆-碳钢镀锌 胶垫-橡胶 颜色: 底盘-黑色 胶垫-黑色

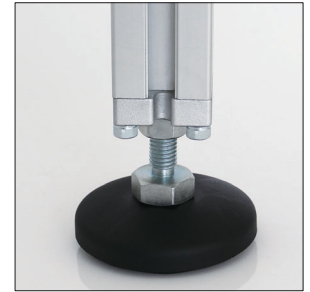
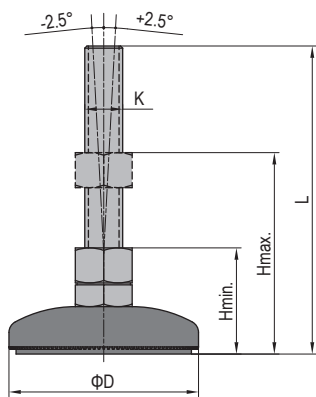
Pivot Foot
尼龙微调支脚

Description 产品描述	D (mm)	KxL (mm)	H min. (mm)	H max. (mm)	Max. Static Load 最大静态载荷 (N)	Mass 重量 (g)	Part No. 订购编号
Pivot Foot-PA 6 Base 尼龙微调支脚 -增强尼龙6底盘	59	M12x90	45	70	4500	152	5.21.60.12.90
		M14x130		100	7000	220	5.21.60.14.130
	79	M12x90	45	70	9000	188	5.21.80.12.90
		M12x130		100		218	5.21.80.12.130
		M16x130		100		328	5.21.80.16.130
	99	M12x130	45	100	10000	326	5.21.100.12.130
M16x130		100		436		5.21.100.16.130	

Leveling Foot-Swivel Foot
支脚-球头

To support structure where gradual height adjustment is needed, the swivel foot has a ball joint between the base and spindle, thus allowing the foot to swivel to an angle up to 30°. It is suitable to be used on the components moved frequently.

球头支脚用来支撑需要调整高度的框架结构, 底盘和牙杆间有球头连接, 因此牙杆旋转角度可达30度, 适用于需要频繁移动的组件。

Material and Color: Base-black PA6 Spindle-zinc plated steel Pad-black rubber
 材质: 底盘-增强尼龙6 牙杆-碳钢镀锌 胶垫-橡胶 颜色: 底盘-黑色 胶垫-黑色

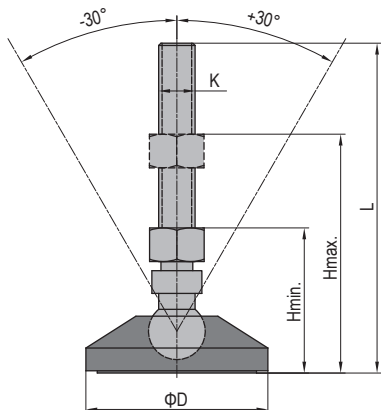
Swivel Foot
球头支脚

Description 产品描述	D (mm)	KxL (mm)	H min. (mm)	H max. (mm)	Max. Static Load 最大静态载荷 (N)	Mass 重量 (g)	Part No. 订购编号
Swivel Foot-PA 6 Base 球头支脚 -增强尼龙6底盘	59	M12x90	45	70	4500	162	5.22.60.12.90
		M12x90		70	9000	198	5.22.80.12.90
	79	M12x130	45	100		228	5.22.80.12.130
		M16x130	100	338		5.22.80.16.130	
	99	M12x130	45	100	10000	336	5.22.100.12.130
		M16x130		100		446	5.22.100.16.130



Floor Elements
地面组件
Leveling Foot-Swivel Foot with holes
支脚-带孔球头

New!

To support structure where gradual height adjustment is needed, the swivel foot has a ball joint between the base and spindle, thus allowing the foot to swivel to an angle up to 30°. It is suitable for uneven surface and fixed with expansion bolts.

球头带孔支脚用来支撑需要调整高度的框架结构，底盘和牙杆之间有球头连接，因此牙杆旋转角度可达30度，可以自适应不平整的固定面，适应后可用膨胀螺栓固定。

Material and Color: Base-black PA6 Spindle-zinc plated steel Pad-black rubber
 材质：底盘-增强尼龙6 牙杆-碳钢镀锌 胶垫-橡胶 颜色：底盘-黑色 胶垫-黑色

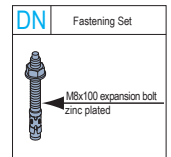
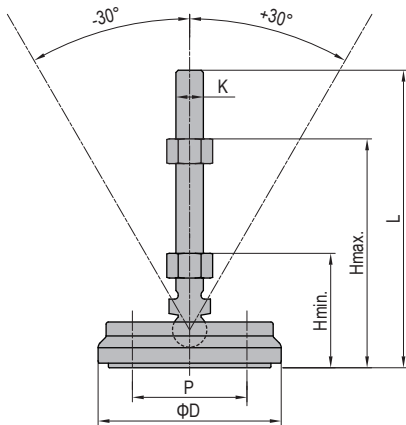
Swivel Foot with holes
带孔球头支脚

Description 产品描述	D (mm)	P (mm)	KxL (mm)	H min. (mm)	H max. (mm)	Max. Static Load 最大静态载荷 (N)	Fastening Set 紧固组件	Mass 重量 (g)	Part No. 订购编号
Swivel Foot with holes-PA 6 Base (pcs) 带孔球头支脚-增强尼龙6底盘 (单个供货)	80	50	M12x130	45	100	9000		217	5.22.80.12.130.DH
Swivel Foot with holes-PA 6 Base (set) 带孔球头支脚-增强尼龙6底盘 (成套供货)			M12x130				2xDN	291	5.22.80.12.130.DH.ST
Swivel Foot with holes-PA 6 Base (pcs) 带孔球头支脚-增强尼龙6底盘 (单个供货)			M16x130					297	5.22.80.16.130.DH
Swivel Foot with holes-PA 6 Base (set) 带孔球头支脚-增强尼龙6底盘 (成套供货)			M16x130				2xDN	371	5.22.80.16.130.DH.ST

Floor Elements
 地面组件

Leveling Foot-Fixed Foot
 支脚-固定

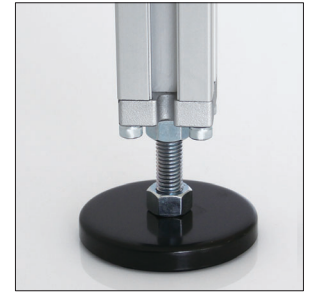
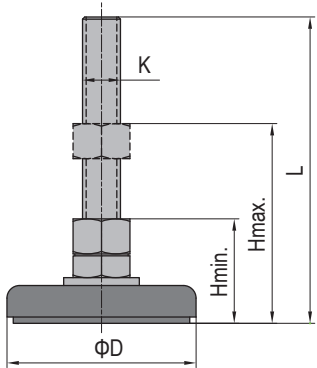

Fixed foot have a non-moving connection between base and spindle.
 固定支脚的牙杆和底盘间是不可活动的。

Material and Color: Base Plate-steel, electrophoresis, black Spindle-zinc plated steel Pad-black rubber
 材质: 底盘-碳钢电泳 牙杆-碳钢镀锌 胶垫-橡胶 颜色: 底盘-黑色 胶垫-黑色

Fixed Foot
 固定支脚

Description 产品描述	D (mm)	KxL (mm)	H min. (mm)	H max. (mm)	Max. Static Load 最大静态载荷 (N)	Mass 重量 (g)	Part No. 订购编号
Fixed Foot-Steel Base 固定支脚-碳钢底盘	40	M12x70	35	50	4000	124	5.23.40.12.70
	60	M12x70	35	50	7000	181	5.23.60.12.70
		M14x70	38	50		225	5.23.60.14.70
	80	M12x70	35	50	9000	220	5.23.80.12.70
		M12x110	35	80		240	5.23.80.12.110
		M14x70	38	50		283	5.23.80.14.70

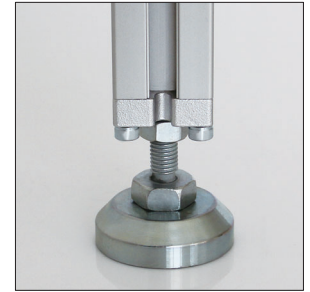
Ad:M14 Fixed Foot should use an end cap with a punched hole
 注: 固定支脚M14使用打孔端盖

Leveling Foot-Pivot Foot
 支脚-金属微调

To support structure where gradual height adjustment is needed, the pivot foot has a small swiveling angle to fit slightly uneven floor. The connection between the pivot base and the spindle can be released with a tool.

金属微调支脚用来支撑需要调整高度的框架结构, 调节角度较小, 适用于相对平整的地面, 此支脚的牙杆和底盘可用工具拆分。

Material: zinc plated steel/stainless steel
 材质: 碳钢镀锌/不锈钢

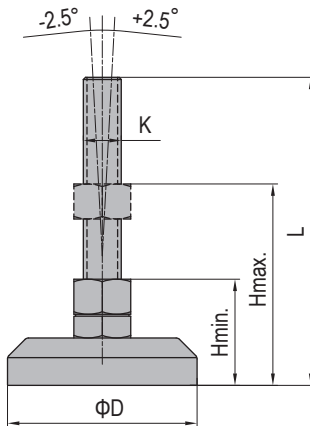
Pivot Foot
 金属微调支脚

Description 产品描述	D (mm)	KxL (mm)	H min. (mm)	H max. (mm)	Max. Static Load 最大静态载荷 (N)	Mass 重量 (g)	Part No. 订购编号
Pivot Foot-Zinc Plate Steel 金属微调支脚-碳钢镀锌	40	M12x128	45	100	15000	241	5.24.40.12.130
		M14x128	45	100	17000	290	5.24.40.14.130
	60	M12x128	45	100	15000	475	5.24.60.12.130
		M14x128	45	100	17000	523	5.24.60.14.130
		M16x158	45	120	20000	596	5.24.60.16.160
		M20x178	50	130	25000	796	5.24.60.20.180
	80	M12x128	45	100	15000	670	5.24.80.12.130
		M14x128	45	100	17000	741	5.24.80.14.130 New!
		M16x158	45	120	20000	780	5.24.80.16.160
		M20x178	50	130	25000	945	5.24.80.20.180
Pivot Foot-Stainless Steel 金属微调支脚-不锈钢	40	M12x128	45	100	15000	240	5.24.40.12.130.SS
	60	M12x128	45	100	15000	480	5.24.60.12.130.SS
		M16x158	45	120	20000	600	5.24.60.16.160.SS
		M20x178	50	130	25000	803	5.24.60.20.180.SS
	80	M12x128	45	100	15000	675	5.24.80.12.130.SS
		M16x158	45	120	20000	785	5.24.80.16.160.SS
		M20x178	50	130	25000	950	5.24.80.20.180.SS



Floor Elements
地面组件

Cup pivot foot
支脚-杯形微调

To support structure where gradual height adjustment is needed, the pivot foot has a small swiveling angle to fit slightly uneven floor. The connection between the pivot base and the spindle can be released with a tool.
杯形微调支脚用来支撑需要调整高度的框架结构，调节角度较小，适用于相对较平整的地面。此支脚的牙杆和底盘可用工具拆分。

Material: zinc plated steel

材质：底盘-碳钢镀锌 牙杆-碳钢镀锌 胶垫-橡胶 颜色：胶垫-黑色



Cup pivot foot
杯形微调支脚

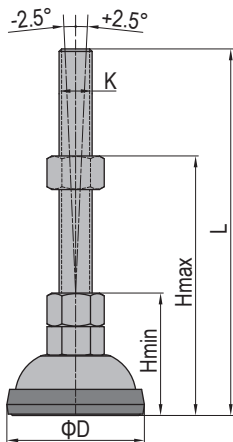

Description 产品描述	D (mm)	KxL (mm)	H min. (mm)	H max. (mm)	Max. Static Load 最大静态载荷 (N)	Mass 重量 (g)	Part No. 订购编号
Cup pivot foot 杯形微调支脚	45	M12x132	50	105	10000	148	5.25.40.12.130
	50					207	5.25.45.12.130

Floor Elements
 地面组件

Mounting Plate
 支脚连接板

To attach leveling foot to strut profile end, but it does not apply for connecting of castors.

连接支脚与型材端面, 不适用于脚轮的连接。

Material: diecast aluminum

材质: 压铸铝合金

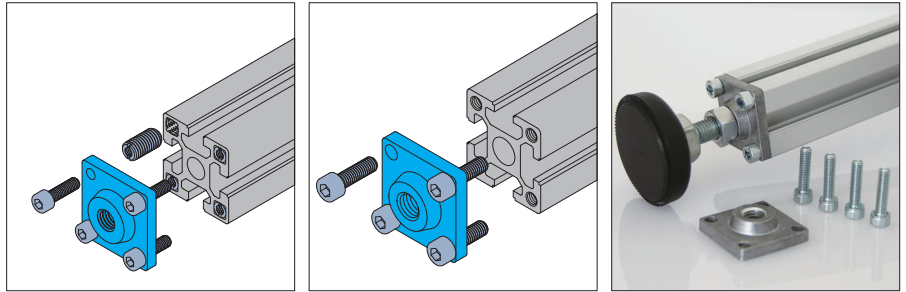

PG40-40x40
 PG45-45x45
 PG50-50x50

PG40-40x60
 PG45-45x60

PG40-40x80
 PG45-45x90

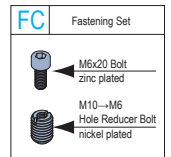
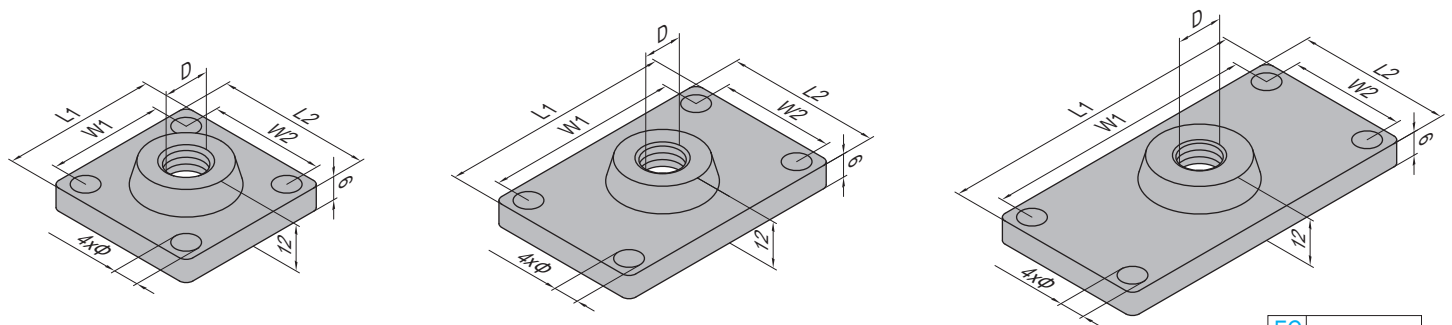

Description 产品描述	D	Φ	L1 (mm)	L2 (mm)	W1 (mm)	W2 (mm)	Fastening Set 紧固组件	Mass 重量 (g)	Part No. 订购编号
Mounting Plate-PG40-4040 支脚连接板-40系列-4040	M12	6.5	40	40	30	30	4x(M6x20)	51	5.31.40.4040
Mounting Plate-PG45-4545 支脚连接板-45系列-4545	M12	6.5	45	45	33	33	4xFC	97	5.31.45.4545
Mounting Plate-PG50-5050 支脚连接板-50系列-5050	M12	8.5	50	50	35	35	4x(M8x30)	130	5.31.50.5050
Mounting Plate-PG40-4060 支脚连接板-40系列-4060	M12	6.5	60	40	50	30	4x(M6x20)	67	5.31.40.4060
Mounting Plate-PG45-4560 支脚连接板-45系列-4560	M12	6.5	60	45	48	33	4xFC	108	5.31.45.4560
Mounting Plate-PG40-4080 支脚连接板-40系列-4080	M12	6.5	80	40	70	30	4x(M6x20)	78	5.31.40.4080.M12
	M16						4x(M6x20)	78	5.31.40.4080.M16
Mounting Plate-PG45-4590 支脚连接板-45系列-4590	M12	6.5	90	45	78	33	4xFC	131	5.31.45.4590.M12
	M16						4xFC	128	5.31.45.4590.M16



Floor Elements
 地面组件

Mounting Plate
 支脚连接板

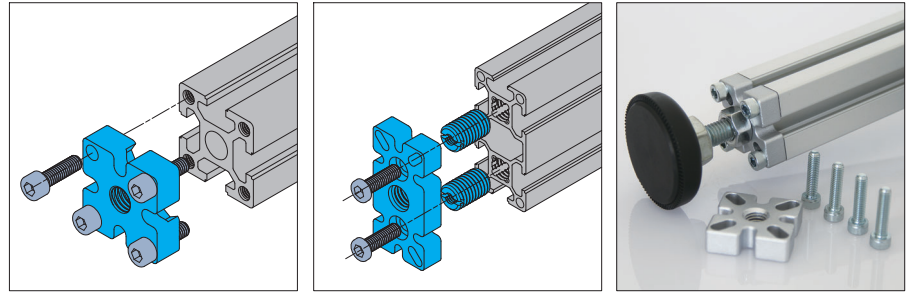

To attach leveling foot or castor to strut profile end.
 连接支脚或脚轮与型材端面。
 Material and Color: spray coating steel, silver
 材质: 碳钢喷涂 颜色: 银色



Reliability 强度:	★★★★★
Efficiency 安装效率:	★★★★★
Economical 经济:	★★★

 PG40-4040
 PG45-4545
 PG50-5050

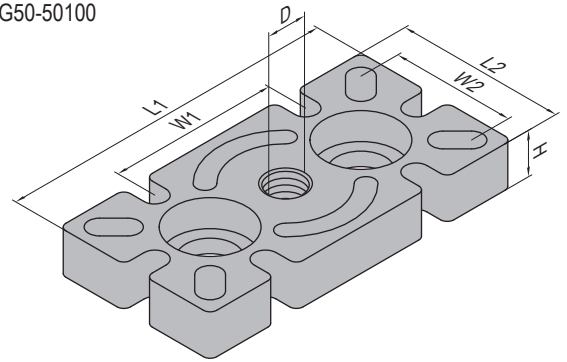
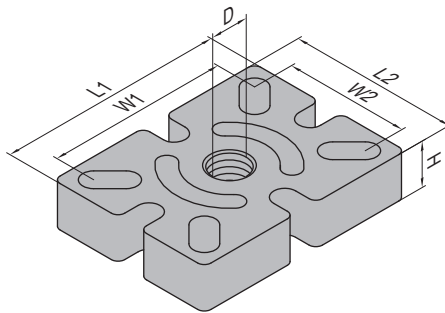
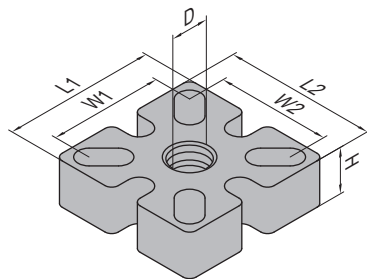
 PG40-4060
 PG45-4560

 PG30-3060
 PG40-4080
 PG45-4590
 PG50-50100

FI Fastening Set	FZ Fastening Set
M6x25 Bolt zinc plated	M6x20 Bolt zinc plated
M10-M6 Hole Reducer Bolt nickel plated	M12-M6 Hole Reducer Bolt nickel plated

Description 产品描述	D	L1 (mm)	L2 (mm)	W1 (mm)	W2 (mm)	H (mm)	Fastening Set 紧固组件	Mass 重量 (g)	Part No. 订购编号
Mounting Plate-PG40-4040 支脚连接板-40系列-4040	M12	40	40	30	30	12	4x(M6x20)	128	5.32.40.4040
Mounting Plate-PG45-4545 支脚连接板-45系列-4545	M12	45	45	33	33	12	4xFI	203	5.32.45.4545
Mounting Plate-PG50-5050 支脚连接板-50系列-5050	M12	50	50	35	35	12	4x(M8x20)	218	5.32.50.5050
Mounting Plate-PG40-4060 支脚连接板-40系列-4060	M12	60	40	50	30	12	4x(M6x20)	176	5.32.40.4060
Mounting Plate-PG45-4560 支脚连接板-45系列-4560	M12	60	45	48	33	12	4xFI	220	5.32.45.4560
Mounting Plate-PG30-3060 支脚连接板-30系列-3060	M12	60	30	30	23	10	2xFZ	133	5.32.30.3060
Mounting Plate-PG40-4080 支脚连接板-40系列-4080	M12	80	40	40	30	12	2x(M14x25)	272	5.32.40.4080.M12
	M16							270	5.32.40.4080.M16
Mounting Plate-PG45-4590 支脚连接板-45系列-4590	M12	90	45	45	33	12	2x(M14x25)	332	5.32.45.4590.M12
	M16							330	5.32.45.4590.M16
Mounting Plate-PG50-50100 支脚连接板-50系列-50100	M12	100	50	50	35	12	2x(M14x25)	332	5.32.50.50100.M12
	M16							329	5.32.50.50100.M16
	M20							327	5.32.50.50100.M20



Floor Elements
地面组件

Mounting Plate
支脚连接板



To attach leveling foot or castor to strut profile end.
连接支脚或脚轮与型材端面。

Material: spray coating steel, silver
材质: 碳钢喷涂 颜色: 银色

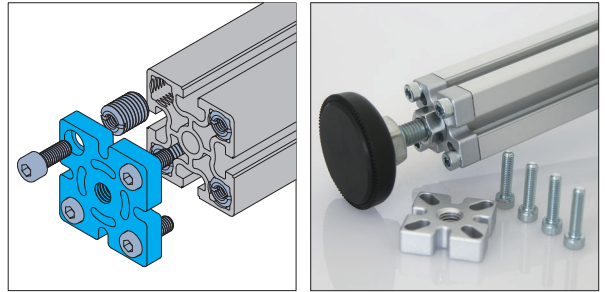

Reliability 强度:	★★★★★
Efficiency 安装效率:	★★★★★
Economical 经济:	★★★

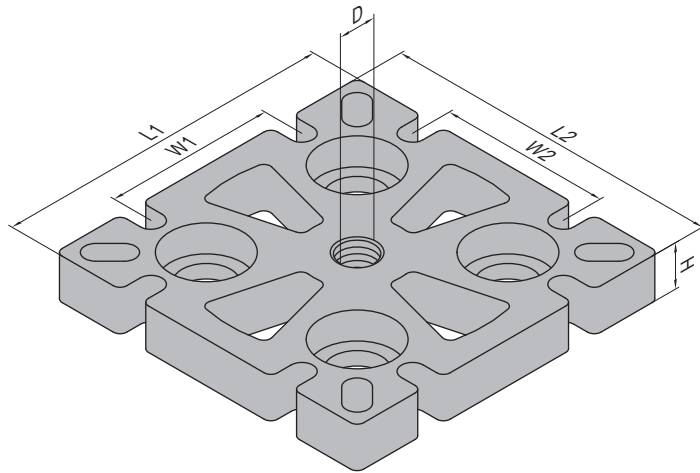

FY	Fastening Set	FZ	Fastening Set
	M8x20 Bolt zinc plated		M6x20 Bolt zinc plated
	M16→M8 Hole Reducer Bolt nickel plated		M12→M6 Hole Reducer Bolt nickel plated

Description 产品描述	D	L1 (mm)	L2 (mm)	W1 (mm)	W2 (mm)	H (mm)	Fastening Set 紧固组件	Mass 重量 (g)	Part No. 订购编号
Mounting Plate-PG30-6060 支脚连接板-30系列-6060	M12	60	60	30	30	10	4xFZ	232	5.32.30.6060.M12
	M16							230	5.32.30.6060.M16
Mounting Plate-PG40-8080 支脚连接板-40系列-8080	M12	80	80	40	40	12	4x(M14x25)	534	5.32.40.8080.M12
	M16							532	5.32.40.8080.M16
	M20							530	5.32.40.8080.M20
Mounting Plate-PG45-9090 支脚连接板-45系列-9090	M12	90	90	45	45	12	4x(M14x25)	664	5.32.45.9090.M12
	M16							661	5.32.45.9090.M16
	M20							659	5.32.45.9090.M20
Mounting Plate-PG50-100100 支脚连接板-50系列-100100	M12	100	100	50	50	12	4x(M14x25)	725	5.32.50.100100.M12
	M16							722	5.32.50.100100.M16
	M20							720	5.32.50.100100.M20
Mounting Plate-PG60-6060 支脚连接板-60系列-6060	M12	60	60	40	40	10	4xFY	330	5.32.60.6060



Floor Elements
地面组件

Mounting Plate
支脚连接板



To attach leveling foot or castor to strut profile end.
连接支脚或脚轮与型材端面。

Material: diecast zinc

材质: 锌合金

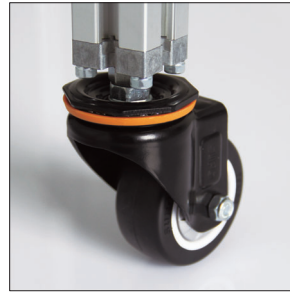
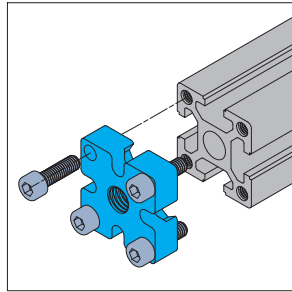

Reliability 强度:	★★★★
Efficiency 安装效率:	★★★★★
Economical 经济:	★★★★

PG40-4040
PG45-4545

PG40-4080
PG45-4590

PG40-8080
PG45-9090

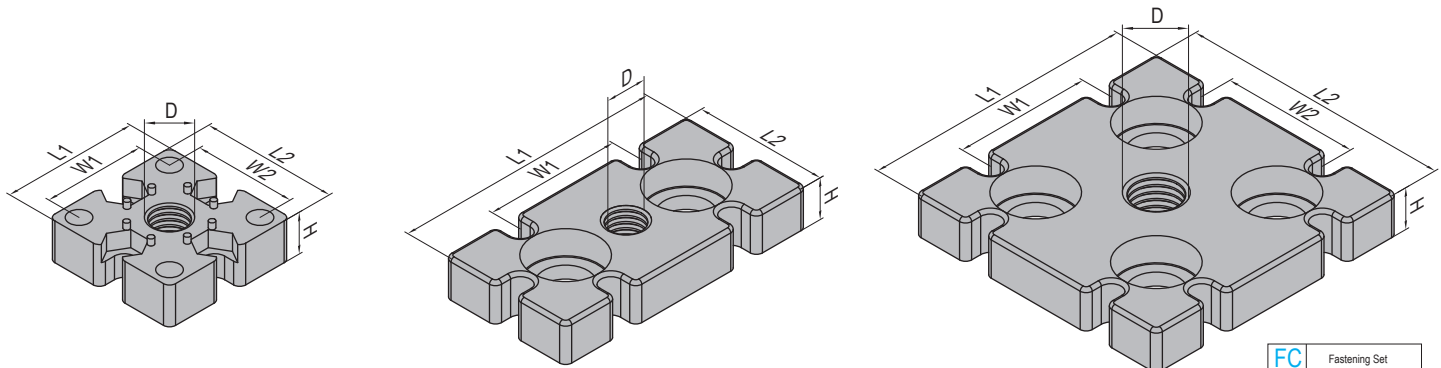

FC	Fastening Set
	M6x20 Bolt zinc plated
	M10-M6 Hole Reducer Bolt nickel plated

Description 产品描述	D	L1 (mm)	L2 (mm)	W1 (mm)	W2 (mm)	H (mm)	Fastening Set 紧固组件	Mass 重量 (g)	Part No. 订购编号
Mounting Plate-PG40-4040 支脚连接板-40系列-4040	M12	40	40	30	30	12	4x(M6x20)	117	5.33.40.4040
Mounting Plate-PG45-4545 支脚连接板-45系列-4545	M12	45	45	33	33	12	4xFC	189	5.33.45.4545
Mounting Plate-PG40-4080 支脚连接板-40系列-4080	M12	80	40	40	40	12	2x(M14x25)	277	5.33.40.4080.M12
	M16							275	5.33.40.4080.M16
Mounting Plate-PG45-4590 支脚连接板-45系列-4590	M12	90	45	45	45	12	2x(M14x25)	344	5.33.45.4590.M12
	M16							342	5.33.45.4590.M16
Mounting Plate-PG40-8080 支脚连接板-40系列-8080	M12	80	80	40	40	12	4x(M14x25)	582	5.33.40.8080.M12
	M16							580	5.33.40.8080.M16
	M20							577	5.33.40.8080.M20
Mounting Plate-PG45-9090 支脚连接板-45系列-9090	M12	90	90	45	45	12	4x(M14x25)	714	5.33.45.9090.M12
	M16							712	5.33.45.9090.M16
	M20							709	5.33.45.9090.M20



Floor Elements
 地面组件

 Castor Plate
 脚轮连接板

The castor plate is used for attaching profiles to the castor with plate.
 此脚轮连接板用于型材平面与底盘式脚轮的连接。

Material: zinc plated steel

材质：碳钢镀锌

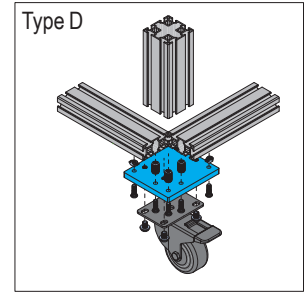
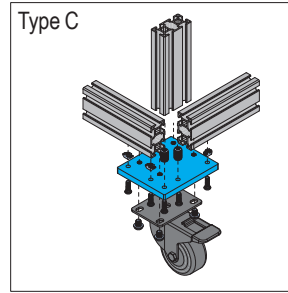
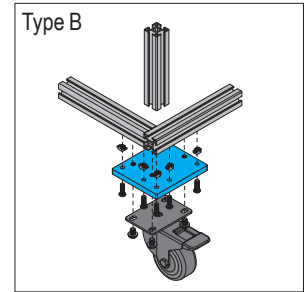
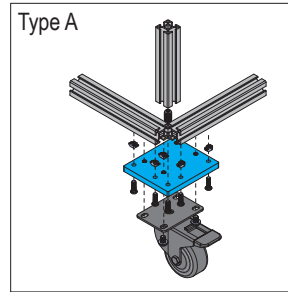
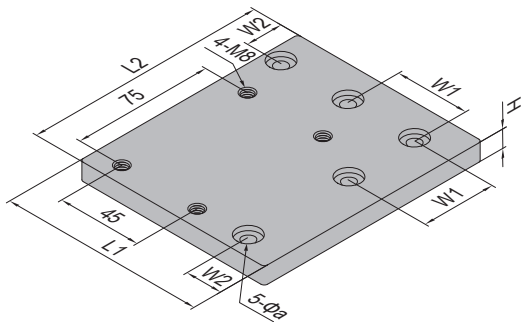
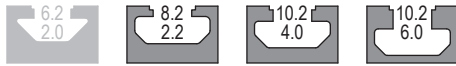

GJ	Fastening Set	GK	Fastening Set	GL	Fastening Set	GM	Fastening Set	AM	Fastening Set	GN	Fastening Set
	M8x20 Bolt zinc plated		M8x25 Bolt zinc plated		M6x16 Bolt zinc plated		M6x20 Bolt zinc plated		M8x12 Bolt zinc plated		M8x25 Bolt zinc plated
	M8 Spring Washer zinc plated		M8 Spring Washer zinc plated		M6 Spring Washer zinc plated		M6 Spring Washer zinc plated		M8 Washer zinc plated		M8 Spring Washer zinc plated
	M8 T Nut nickel plated		M8 T Nut nickel plated		M6 T Nut nickel plated		M12-M6 Hole Reducer Bolt nickel plated				M14-M8 Hole Reducer Bolt nickel plated

Description 产品描述	PG 型材系列	H (mm)	L1 (mm)	L2 (mm)	W1 (mm)	W2 (mm)	Φa (mm)	Fastening Set 紧固组件	Mass 重量 (g)	Part No. 订购编号
Castor Plate A-PG30 脚轮连接板-A型-30系列	PG30	10	105	120	30	15	7	4xGL+1xGM+4xAM	1056	5.34.30.STA
Castor Plate B-PG30 脚轮连接板-B型-30系列								5xGL+4xAM	1049	5.34.30.STB
Castor Plate C-PG30 脚轮连接板-C型-30系列								3xGL+2xGM+4xAM	1063	5.34.30.STC
Castor Plate D-PG30 脚轮连接板-D型-30系列								2xGL+3xGM+4xAM	1070	5.34.30.STD
Castor Plate A-PG40 脚轮连接板-A型-40系列	PG40	12	110	130	40	20	9	4xGJ+1xGN+4xAM	1229	5.34.40.STA
Castor Plate B-PG40 脚轮连接板-B型-40系列								5xGJ+4xAM	1222	5.34.40.STB
Castor Plate C-PG40 脚轮连接板-C型-40系列								3xGJ+2xGN+4xAM	1236	5.34.40.STC
Castor Plate D-PG40 脚轮连接板-D型-40系列								2xGJ+3xGN+4xAM	1243	5.34.40.STD
Castor Plate A-PG45 脚轮连接板-A型-45系列	PG45	12	120	130	45	22.5	9	4xGK+1xGN+4xAM	1237	5.34.45.STA
Castor Plate B-PG45 脚轮连接板-B型-45系列								5xGK+4xAM	1230	5.34.45.STB
Castor Plate C-PG45 脚轮连接板-C型-45系列								3xGK+2xGN+4xAM	1244	5.34.45.STC
Castor Plate D-PG45 脚轮连接板-D型-45系列								2xGK+3xGN+4xAM	1251	5.34.45.STD



Floor Elements
 地面组件

 Castor Plate-Heavy
 重载脚轮连接板

The castor plate is used for attaching profiles to the castor with plate-Heavy.
 此脚轮连接板用于型材平面与重载脚轮的连接。

Material: zinc plated steel

材质: 碳钢镀锌

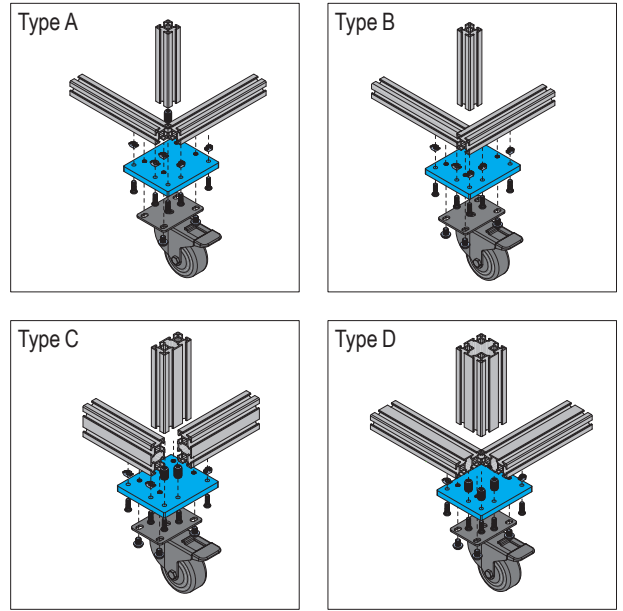
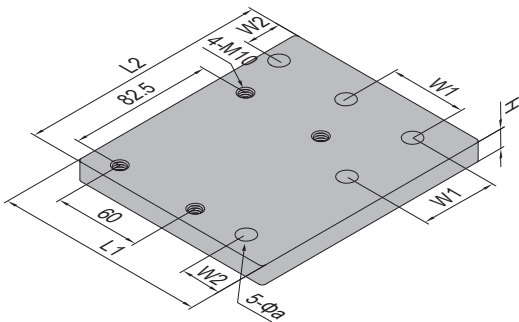
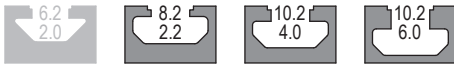

DO	Fastening Set	DQ	Fastening Set	DS	Fastening Set	DP	Fastening Set	DR	Fastening Set
	M6x20 Bolt zinc plated		M6x20 Bolt zinc plated		M10x16 Bolt zinc plated		M8x25 Bolt zinc plated		M8x25 Bolt zinc plated
	M6 Spring Washer zinc plated		M6 Spring Washer zinc plated		M10 Washer zinc plated		M8 Spring Washer zinc plated		M8 Spring Washer zinc plated
	M6 Washer zinc plated		M6 Washer zinc plated				M8 Washer zinc plated		M8 Washer zinc plated
	M6 T Nut zinc plated		M6 T Nut zinc plated				M8 T Nut zinc plated		M8 T Nut zinc plated
	M6 T Nut nickel plated		M6 T Nut nickel plated				M8 T Nut nickel plated		M8 T Nut nickel plated

Description 产品描述	PG 型材系列	H (mm)	L1 (mm)	L2 (mm)	W1 (mm)	W2 (mm)	Φa (mm)	Fastening Set 紧固组件	Mass 重量 (g)	Part No. 订购编号
Castor Plate-Heavy A-PG30 重载脚轮连接板-A型-30系列	PG30	10	120	135	30	15	7	4xDO+1xDQ+4xDS	1364	5.34.30.H.STA
Castor Plate-Heavy B-PG30 重载脚轮连接板-B型-30系列								5xDO+4xDS	1356	5.34.30.H.STB
Castor Plate-Heavy C-PG30 重载脚轮连接板-C型-30系列								3xDO+2xDQ+4xDS	1372	5.34.30.H.STC
Castor Plate-Heavy D-PG30 重载脚轮连接板-D型-30系列								2xDO+3xDQ+4xDS	1380	5.34.30.H.STD
Castor Plate-Heavy A-PG40 重载脚轮连接板-A型-40系列	PG40	12	125	145	40	20	9	4xDP+1xDR+4xDS	1834	5.34.40.H.STA
Castor Plate-Heavy B-PG40 重载脚轮连接板-B型-40系列								5xDP+4xDS	1826	5.34.40.H.STB
Castor Plate-Heavy C-PG40 重载脚轮连接板-C型-40系列								3xDP+2xDR+4xDS	1842	5.34.40.H.STC
Castor Plate-Heavy D-PG40 重载脚轮连接板-D型-40系列								2xDP+3xDR+4xDS	1850	5.34.40.H.STD
Castor Plate-Heavy A-PG45 重载脚轮连接板-A型-45系列	PG45	12	135	145	45	22.5	9	4xDP+1xDR+4xDS	1969	5.34.45.H.STA
Castor Plate-Heavy B-PG45 重载脚轮连接板-B型-45系列								5xDP+4xDS	1972	5.34.45.H.STB
Castor Plate-Heavy C-PG45 重载脚轮连接板-C型-45系列								3xDP+2xDR+4xDS	1977	5.34.45.H.STC
Castor Plate-Heavy D-PG45 重载脚轮连接板-D型-45系列								2xDP+3xDR+4xDS	1985	5.34.45.H.STD



Floor Elements
地面组件

Castor Plate
脚轮连接板



The castor plate is used for attaching profiles to the castor with thread.
此脚轮连接板用于型材平面与牙杆式脚轮的连接。

Material: zinc plated steel

材质：碳钢镀锌

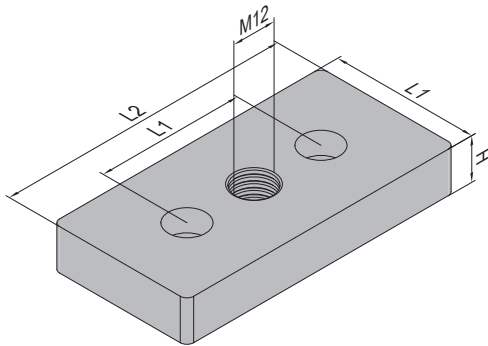
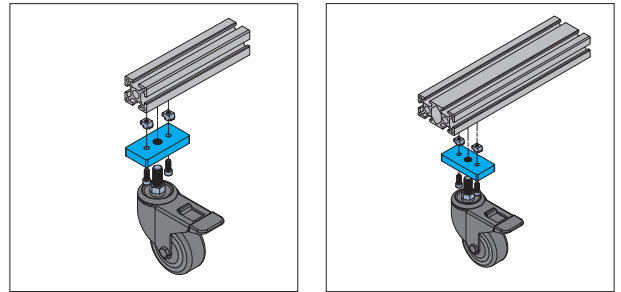

FS	Fastening Set	CQ	Fastening Set
	M6x10 Bolt zinc plated		M6x16 Bolt zinc plated
	M6 T Nut nickel plated		M6 T Nut nickel plated

Description 产品描述	PG 型材系列	H (mm)	L1 (mm)	L2 (mm)	Fastening Set 紧固组件	Mass 重量 (g)	Part No. 订购编号
Castor Plate-PG30 脚轮连接板-30系列	PG30	10	30	60	2xFS	162	5.35.30.ST
Castor Plate-PG40 脚轮连接板-40系列	PG40	12	40	80	2xCQ	296	5.35.40.ST
Castor Plate-PG45 脚轮连接板-45系列	PG45	12	45	90	2xCQ	377	5.35.45.ST

When the castor is installed with this castor plate, the profile need be machined with a $\Phi 12.5$ and 20mm depth hole at the corresponding position to the thread of the castor.

使用此方式安装脚轮时，型材对应脚轮牙杆的位置需要加工1个 $\Phi 12.5$ 深20mm的孔。

Floor Elements
地面组件

Castor
脚轮

Material and Color: Base-carbon steel, plastic powder coated, black
Wheel-polyurethane(Heavy duty - Nylon)
材质: 底座-碳钢喷塑 轮-聚氨酯(重载轮-尼龙) 颜色: 底座-黑色

Castor-Thread-Universal
脚轮-牙杆-万向

Castor-Thread-Brake-Universal
脚轮-牙杆-刹车-万向

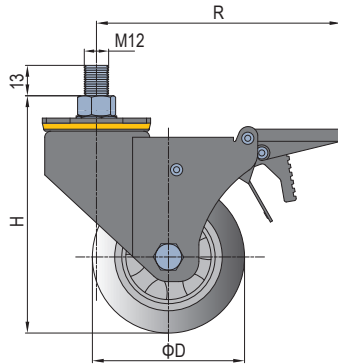
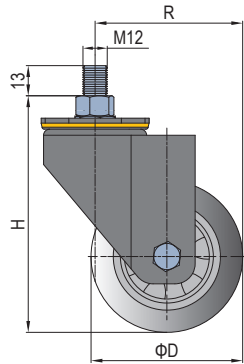

Castor-Plate-Universal
脚轮-底盘-万向

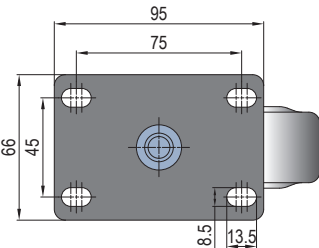
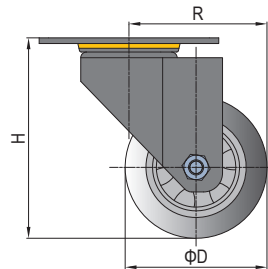

Castor-Plate-Fixed
脚轮-底盘-定向

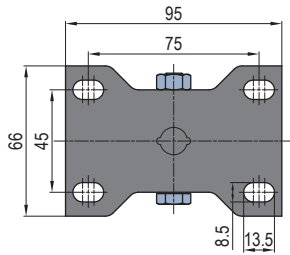
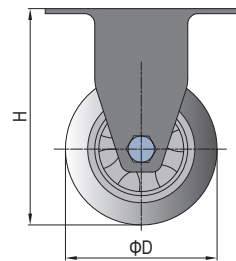

Castor-Plate-Universal-Brake
脚轮-底盘-万向-刹车

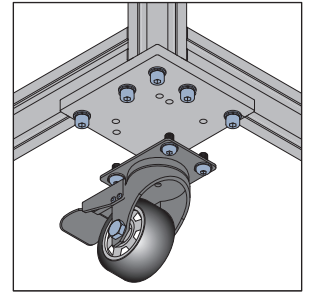
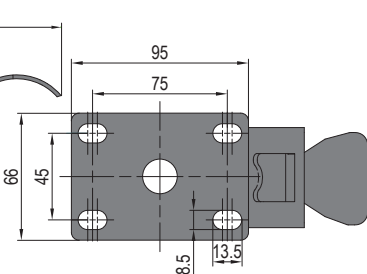
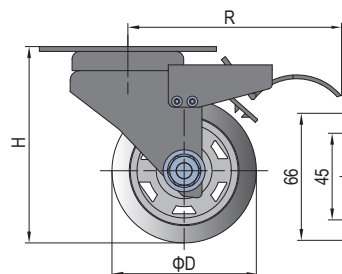

Castor-Plate-Universal-Heavy
脚轮-底盘-万向-重载

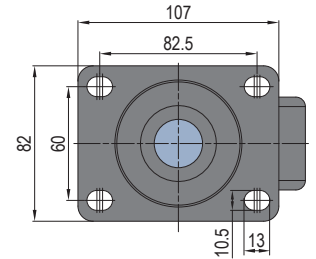
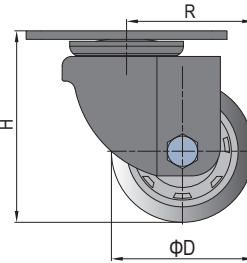

Castor-Plate-Fixed-Heavy
脚轮-底盘-定向-重载

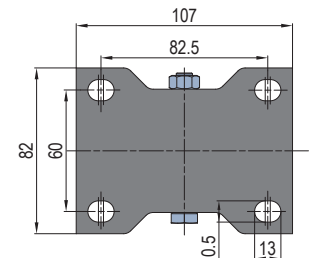
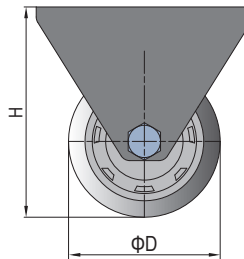

Description 产品描述	Wheel Width 轮宽 (mm)	D (mm)	R (mm)	H (mm)	Load 载荷 (N)	Mass 重量 (g)	Part No. 订购编号
Castor-Thread-Universal 脚轮-牙杆-万向	32	63	63	104	800	550	5.41.63.M12
	32	75	73	119	1050	670	5.41.75.M12
	32	100	87	142	1350	790	5.41.100.M12
Castor-Thread-Brake-Universal 脚轮-牙杆-刹车-万向	32	63	112	104	800	650	5.41.63.M12B
	32	75	112	119	1050	770	5.41.75.M12B
	32	100	122	142	1350	930	5.41.100.M12B
Castor-Plate-Universal 脚轮-底盘-万向	32	63	63	92	800	570	5.41.63U
	32	75	73	107	1050	690	5.41.75U
	32	100	87	130	1350	870	5.41.100U
Castor-Plate-Fixed 脚轮-底盘-定向	32	63		92	800	370	5.41.63F
	32	75		107	1050	490	5.41.75F
	32	100		130	1350	670	5.41.100F
Castor-Plate-Universal-Brake 脚轮-底盘-万向-刹车	32	63	118	92	800	670	5.41.63B
	32	75	118	107	1050	790	5.41.75B
	32	100	127	130	1350	970	5.41.100B
Castor-Plate-Universal-Heavy 脚轮-底盘-万向-重载	50	75	65	104	6000	1150	5.41.75UH
Castor-Plate-Fixed-Heavy 脚轮-底盘-定向-重载	50	75		104	6000	950	5.41.75FH

Floor Elements
地面组件

Base Angle
板支脚

To improve stability of structure supported by leveling foot.
板支脚配合支脚，有辅助支撑的作用，使框架更加稳定牢固。
Material: steel, black electrophoresis
材质：碳钢 表面处理：黑色电泳

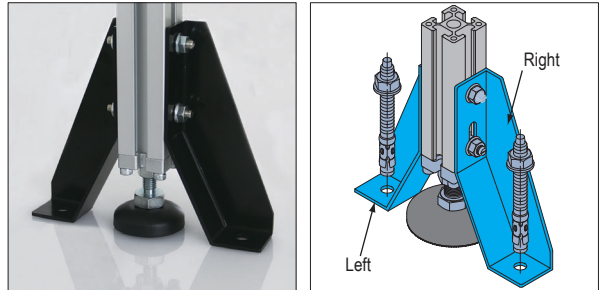

Base Angle-Left/Right
板支脚-左/右

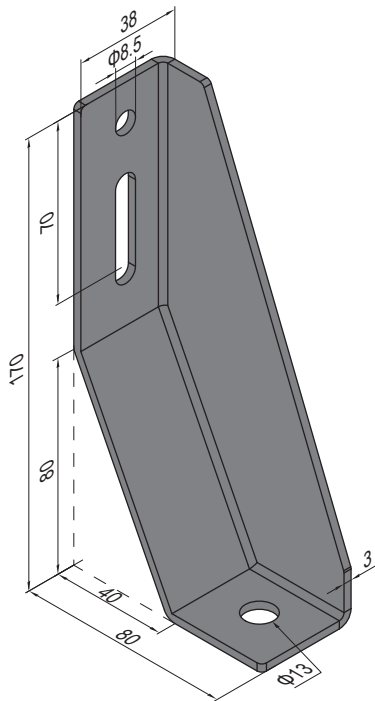

C	Fastening Set	AA	Fastening Set
	M8 Flange Nut zinc plated		M10x100 expansion bolt zinc plated
	M8x20 T Bolt nickel plated		

Description 产品描述	Fastening Set 紧固组件	Mass 重量 (g)	Part No. 订购编号
Base Angle-Left (pcs) 板支脚-左 (单个供货)		346	5.51.L
Base Angle-Left (set) 板支脚-左 (成套供货)	2xC+1xAA	473	5.51.L.ST
Base Angle-Right (pcs) 板支脚-右 (单个供货)		346	5.51.R
Base Angle-Right (set) 板支脚-右 (成套供货)	2xC+1xAA	473	5.51.R.ST
Base Angle-L+R (pair) 板支脚-左+右 (成对供货)		692	5.51.P
Base Angle-L+R (set) 板支脚-左+右 (成对成套供货)	4xC+2xAA	946	5.51.P.ST

Floor Elements
地面组件

L Base

L 形支脚

L base is to fix the profile on the floor and adjust the height of the profile to the floor.

L 形支脚可将型材紧固于地面上，并可调节型材距离地面的高度。

Material: diecast aluminum, black electrophoresis

材质: 压铸铝合金 表面处理: 黑色电泳

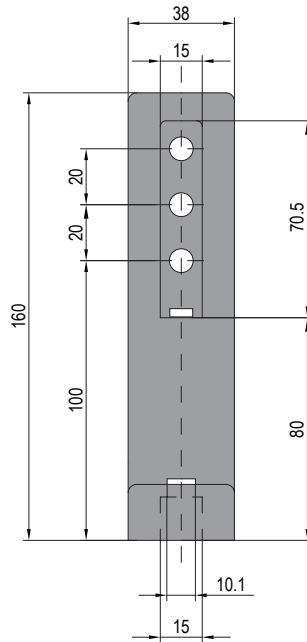
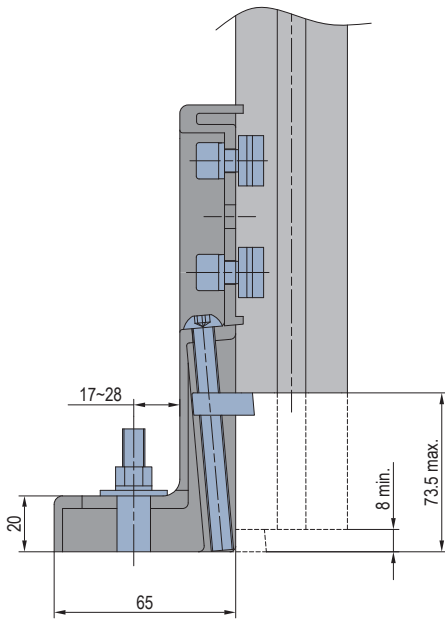
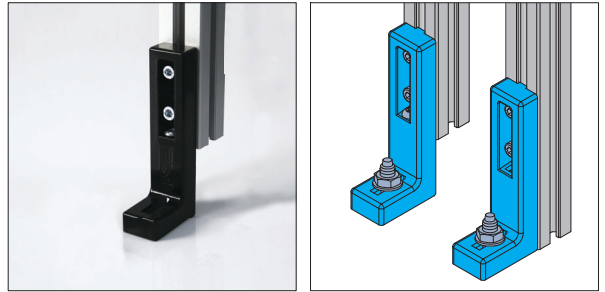

DI	Fastening Set	DM	Fastening Set	DN	Fastening Set
	M8x16 Bolt zinc plated		M8x20 Bolt zinc plated		M10x100 expansion bolt zinc plated
	M8 Spring Washer zinc plated		M8 Spring Washer zinc plated		
	M8 Pre-set Nut nickel plated		M8 Pre-set Nut nickel plated		

Description 产品描述	Fastening Set 紧固组件	Mass 重量 (g)	Part No. 订购编号
L Base (pcs) L 形支脚 (单个供货)		276	5.52.10
L Base-PG40 (set) L 形支脚-40系列 (成套供货)	2xDI+1xDN	343	5.52.10.04.ST
L Base-PG45 (set) L 形支脚-45系列 (成套供货)	2xDM+1xDN	346	5.52.10.06.ST

Floor Elements
地面组件

Foot and Castor Components
支脚万向轮组件



Light
轻载

Wheel-polyurethane, Foot-steel, black electrophoresis, plate-diecast aluminum
材质: 轮-聚氨酯 支脚-碳钢电泳 板-压铸铝合金

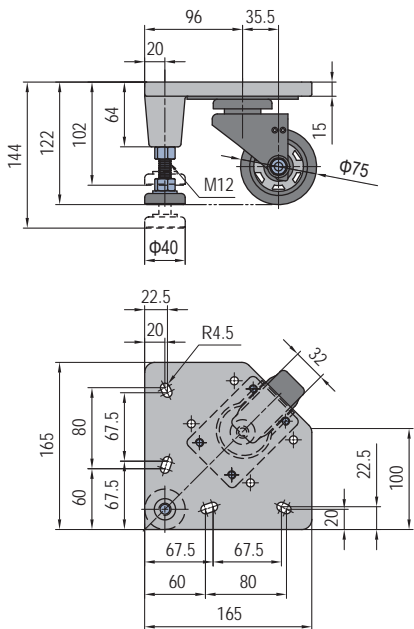

Heavy
重载

Wheel-PA, Foot-zinc plated steel, plate-cast steel, silver color
材质: 轮-尼龙 支脚-碳钢镀锌 板-铸钢 颜色: 板-银色

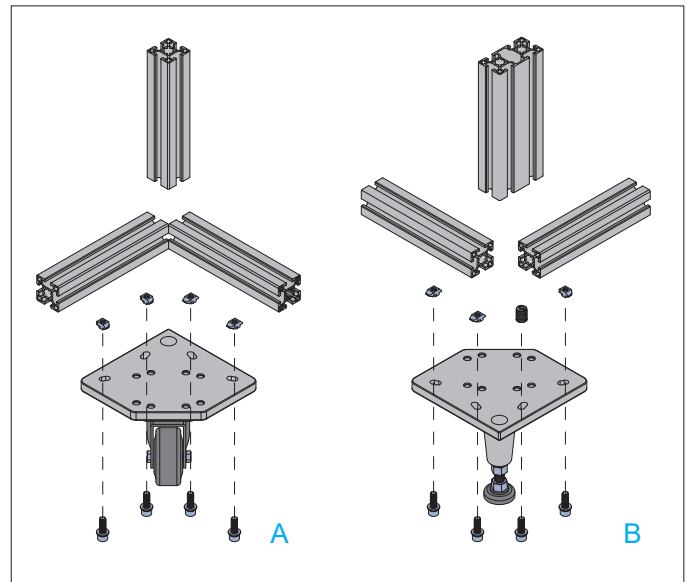
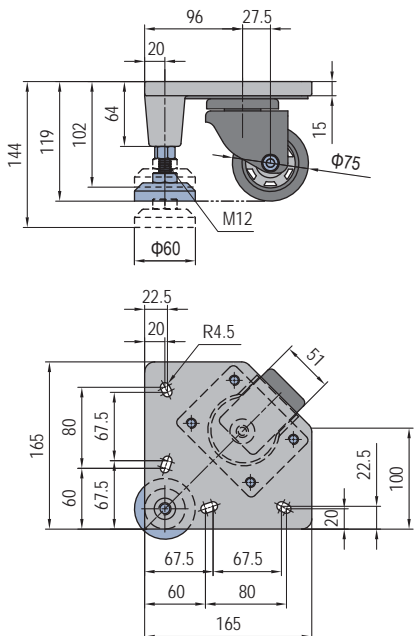

AF	Fastening Set	AG	Fastening Set	J	Fastening Set	W	Fastening Set
	M8x25 Bolt zinc plated		M8x30 Bolt zinc plated		M8x25 Bolt zinc plated		M8x30 Bolt zinc plated
	M8 Spring Washer zinc plated		M8 Spring Washer zinc plated		M8 Spring Washer zinc plated		M8 Spring Washer zinc plated
	M8 Washer zinc plated		M8 Washer zinc plated		M8 Washer zinc plated		M8 Washer zinc plated
	M12-1.5 M16 Reducer Bolt nickel plated		M14-1.5 M16 Reducer Bolt nickel plated		M8 T Nut nickel plated		M8 T Nut nickel plated

Description 产品描述	Fastening Set 紧固组件	Load 载荷 (N)	Mass 重量 (g)	Part No. 订购编号
Light Weight (pcs) 支脚万向轮组件 轻载 (单个供货)		1050	1780	5.61.L
Light Weight (set) 支脚万向轮组件 轻载 (成套供货)	4xJ		1830	5.61.40.L.STA
	3xJ+1xAF		1830	5.61.40.L.STB
	4xW		1830	5.61.45.L.STA
Heavy Weight (pcs) 支脚万向轮组件 重载 (单个供货)	3xW+1xAG	1830	5.61.45.L.STB	
		6000	4600	5.61.H
Heavy Weight (set) 支脚万向轮组件 重载 (成套供货)	4xJ		4650	5.61.40.H.STA
	3xJ+1xAF		4650	5.61.40.H.STB
	4xW		4650	5.61.45.H.STA
	3xW+1xAG		4650	5.61.45.H.STB



Floor Elements
地面组件

Leveling Castor
水平调节轮

Material: Base-Carbon steel, Case-Aluminum, Wheel-Nylon 6
材质: 底座-碳钢 壳体-铝制 轮-尼龙6

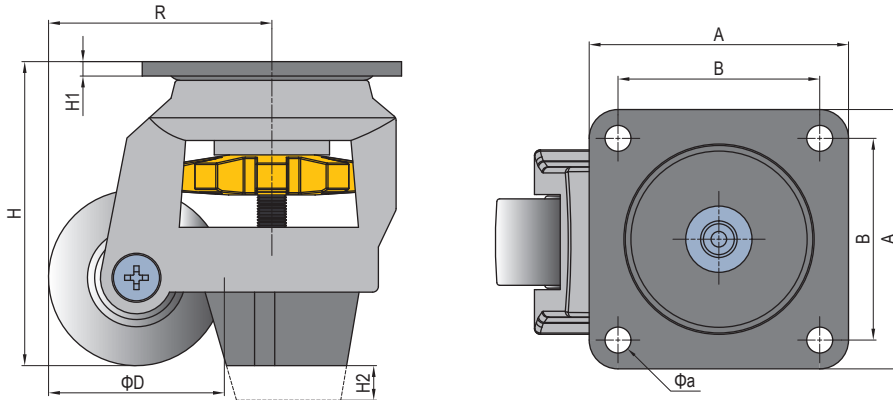

Description 产品描述	Wheel Width 轮宽 (mm)	D (mm)	R (mm)	H (mm)	H ₁ (mm)	H ₂ (mm)	A (mm)	B (mm)	a (mm)	Load 载荷 (N)	Mass 重量 (kg)	Part No. 订购编号
Leveling Castor 水平调节轮	22	50	62	83	4	10	73	58	7	1700	0.69	5.62.60F
	29	62	77	102	5	12	90	70	9.5	3400	1.31	5.62.80F
	31	72	91	121	6	15	95	70	11.5	6700	1.75	5.62.120F



6.11-6.41

T Slot Reducing Profile
T形槽内嵌条

Panel Mounting Block
板夹块

Panel Mounting Strip
板夹条

Mounting Block
夹网螺母块

6

Panel Installation Elements 板材组件



P. 6-02



P. 6-03



P. 6-04



P. 6-05



Panel Installation Elements
板材组件

T Slot Reducing Profile

T形槽内嵌条

To reduce slot width for panel installation.

T形槽内嵌条用于减小槽宽，方便槽内嵌板。

Material and Color: black PVC

材质: PVC 颜色: 黑色



T Slot Reducing Profile-6

T形槽内嵌条-6

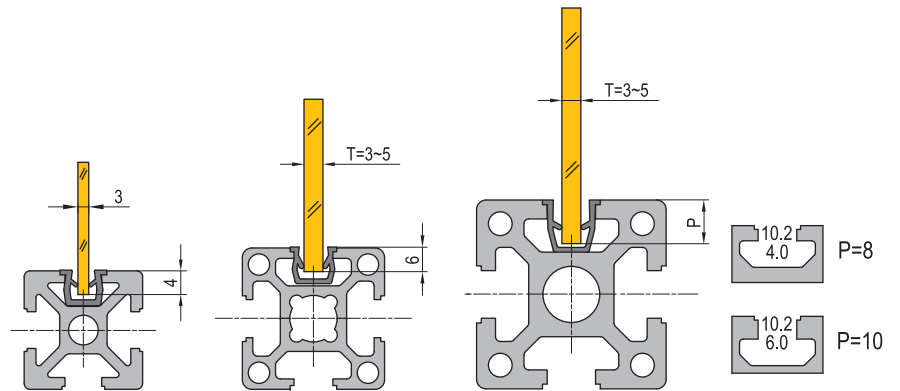
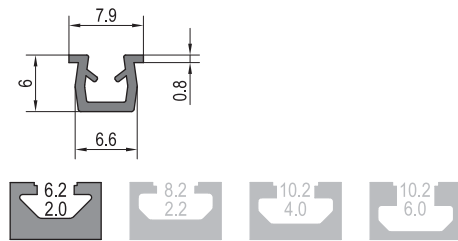

T Slot Reducing Profile-8

T形槽内嵌条-8

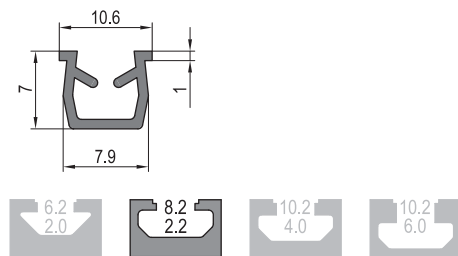

Description 产品描述	Mass 重量 (g/m)	Delivery Length 供货长度	Part No. 订购编号
T Slot Reducing Profile-6 T形槽内嵌条-6	25	2000mm/bar	6.11.06
T Slot Reducing Profile-8 T形槽内嵌条-8	51		6.11.08
T Slot Reducing Profile-10 T形槽内嵌条-10	64		6.11.10

T Slot Reducing Profile-10

T形槽内嵌条-10

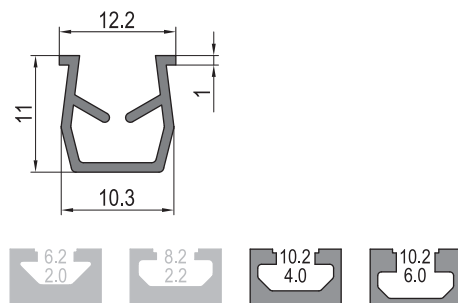

Panel Installation Elements
板材组件

Panel Mounting Block
板夹块

The block is used to attach the panel with various thickness to the profile.
板夹块用于板材与型材的连接，不同的夹面适合不同厚度的板材。
Material and Color: Block-black PVC Nut-stainless steel
材质：夹块-PVC 螺母-不锈钢 颜色：夹块-黑色

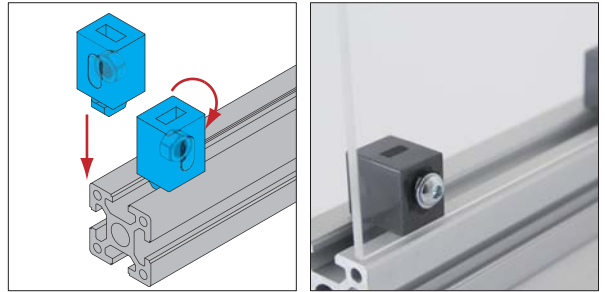

Panel Mounting Block-6
板夹块-6

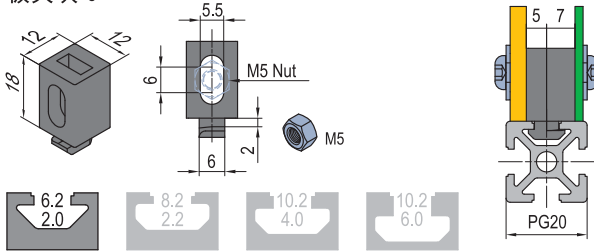

FM	Fastening Set	FN	Fastening Set	FP	Fastening Set
	M5x14 Bolt zinc plated		M6x16 Bolt zinc plated		M6x25 Bolt zinc plated
	M5 Washer zinc plated		M6 Washer zinc plated		M6 Washer zinc plated

Panel Mounting Block-8
板夹块-8

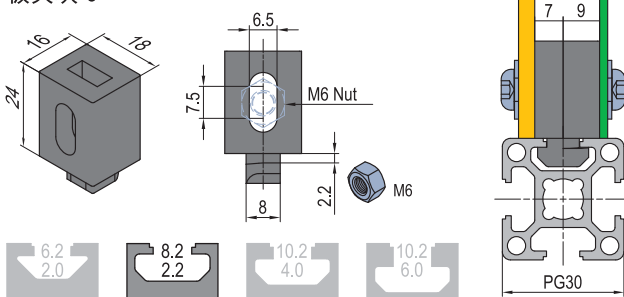

Panel Mounting Block-10-4
板夹块-10-4

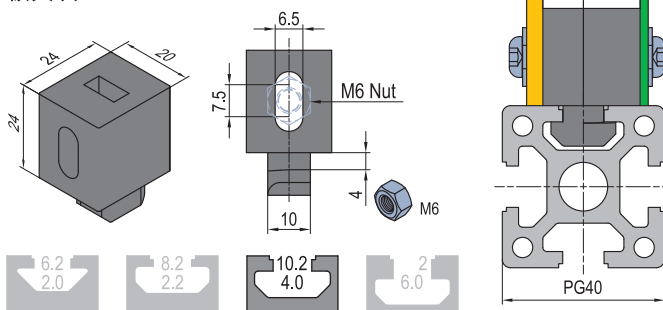

Panel Mounting Block-10-6
板夹块-10-6

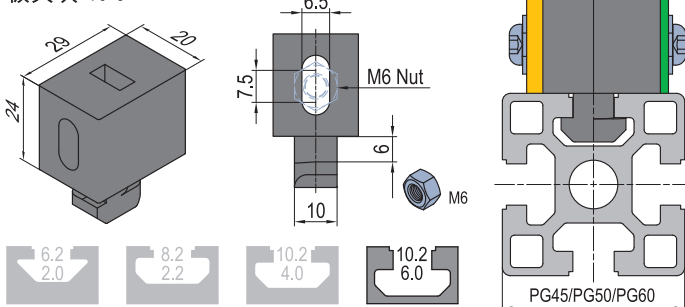

Description 产品描述	PG 型材系列	Fastening Set 紧固组件	Mass 重量 (g)	Part No. 订购编号
Panel Mounting Block-6 (pcs) 板夹块-6 (单个供货)	PG20		4.4	6.21.06
Panel Mounting Block-6 (set) 板夹块-6 (成套供货)		1xFM	7	6.21.06.ST
Panel Mounting Block-8 (pcs) 板夹块-8 (单个供货)	PG30		9	6.21.08
Panel Mounting Block-8 (set) 板夹块-8 (成套供货)		1xFN	13.5	6.21.08.ST
Panel Mounting Block-10-4 (pcs) 板夹块-10-4 (单个供货)	PG40		15.8	6.21.10.04
Panel Mounting Block-10-4 (set) 板夹块-10-4 (成套供货)		1xFP	23.8	6.21.10.04.ST
Panel Mounting Block-10-6 (pcs) 板夹块-10-6 (单个供货)	PG45/50/60		20	6.21.10.06
Panel Mounting Block-10-6 (set) 板夹块-10-6 (成套供货)		1xFP	29	6.21.10.06.ST



Panel Installation Elements
板材组件

Panel Mounting Strip
板夹条

To attach the panel with 3mm and 5mm thickness to the profile, widely used in clean room.

板夹条用于3mm和5mm的板材与型材连接，适用于洁净室。

Material and Color: gray PVC

材质: PVC 颜色: 灰色



Panel Mounting Strip-8-5
板夹条-8-5

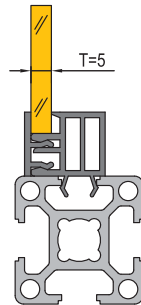
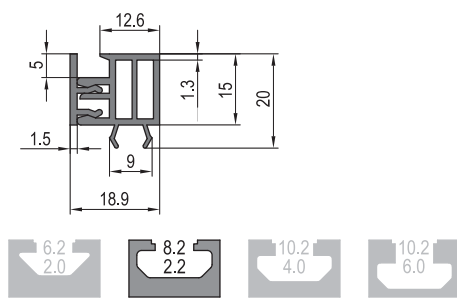

Panel Mounting Strip-10-4-3
板夹条-10-4-3

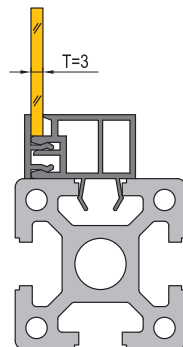
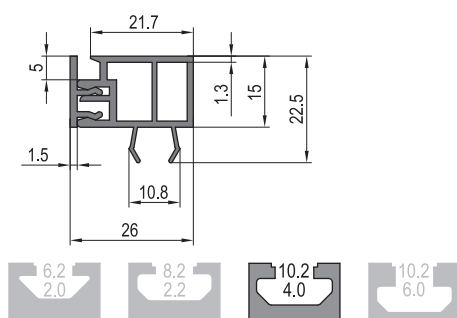

Panel Mounting Strip-10-4-5
板夹条-10-4-5

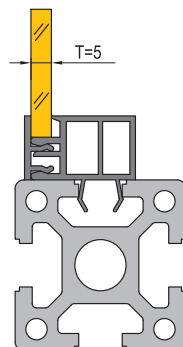
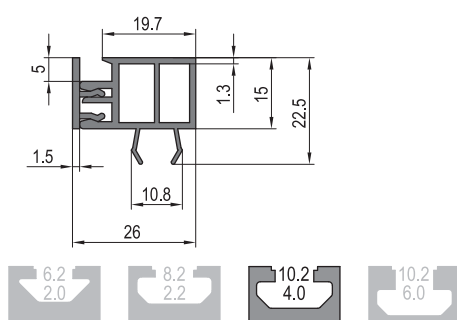

Description 产品描述	PG 型材系列	Mass 重量(g/m)	Delivery length 供货长度	Part No. 订购编号
Panel Mounting Strip-8-5 板夹条-8-5	PG30	220	2000mm/bar	6.31.08.02
Panel Mounting Strip-10-4-3 板夹条-10-4-3	PG40	273		6.31.10.04.01
Panel Mounting Strip-10-4-5 板夹条-10-4-5		260		6.31.10.04.02



Panel Installation Elements
板材组件

Mounting Block
夹网螺母块

Mounting block is used for fixing the mesh of $\Phi 4$ to the standard profiles, which has a better physical property.

夹网螺母块适用于网丝直径为4mm的焊接网和编织网的固定, 拥有较强的连接强度。

Material: diecast zinc
材质: 压铸锌合金

Mounting Block-8
夹网螺母块-8

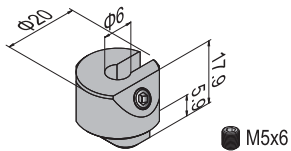

Mounting Block-10-4
夹网螺母块-10-4

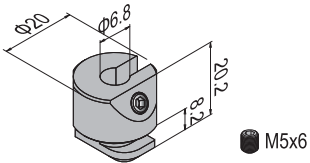

Mounting Block-10-6
夹网螺母块-10-6

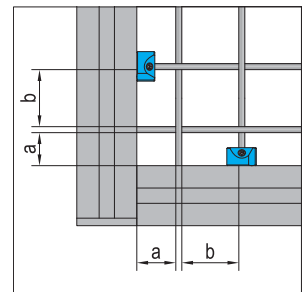
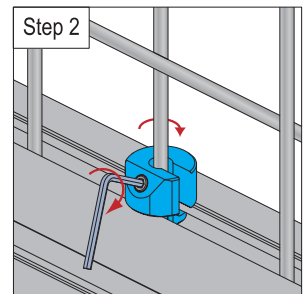
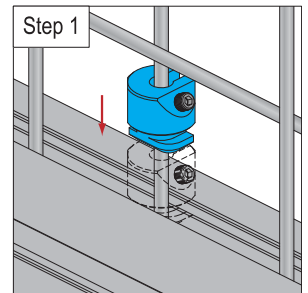
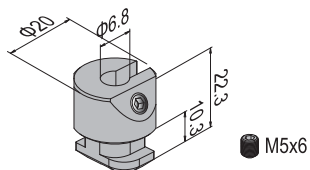

Description 产品描述	PG 型材系列	Mass 重量 (g/pcs)	Part No. 订购编号
Mounting Block-8(with top thread) 夹网螺母块-8(含凹端顶丝)	PG30	19	6.41.08.01
Mounting Block-10-4(with top thread) 夹网螺母块-10-4(含凹端顶丝)	PG40	21	6.41.10.04.01
Mounting Block-10-6(with top thread) 夹网螺母块-10-6(含凹端顶丝)	PG45/50/60	23	6.41.10.06.01

Note: The distance (a) between the nearest meshes and profiles have to be more than 20mm and less than $b+5\text{mm}$ (b is the distance of the meshes). And the optimum distance between mounting blocks is 300mm to ensure the structure intensity.

备注: 1. 网丝与型材间距a需满足 $20\text{mm} < a < b + 5\text{mm}$ (b为该网的网格距离尺寸) 建议螺母块安装间距300mm以确保安装强度。

2. 网丝直径 $< 4\text{mm}$ 时使用 $M5 \times 8$ 的紧定螺钉;
网丝直径 $\geq 4\text{mm}$ 时使用 $M5 \times 6$ 的紧定螺钉。



7.11-7.51

Handle
把手

Hinge
合页

Lock
门锁

Magnet Catch
门碰

Door Lock
门搭扣

Sliding Door Profile
拉门滑道

7

Door and Window Elements 门窗组件



P. 7-02

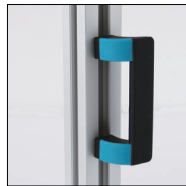

P. 7-03



P. 7-04



P. 7-05



P. 7-06



P. 7-09



P. 7-10

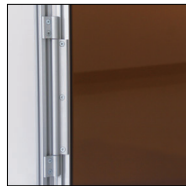

P. 7-11



P. 7-12

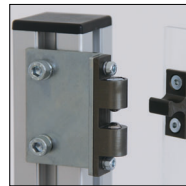

P. 7-14



P. 7-16

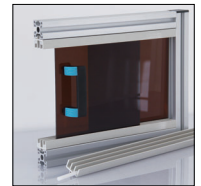

P. 7-17

Door and Window Elements
 门窗组件









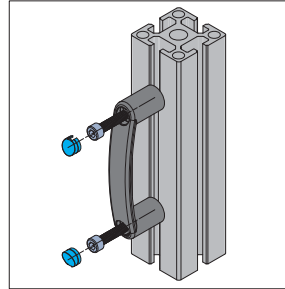
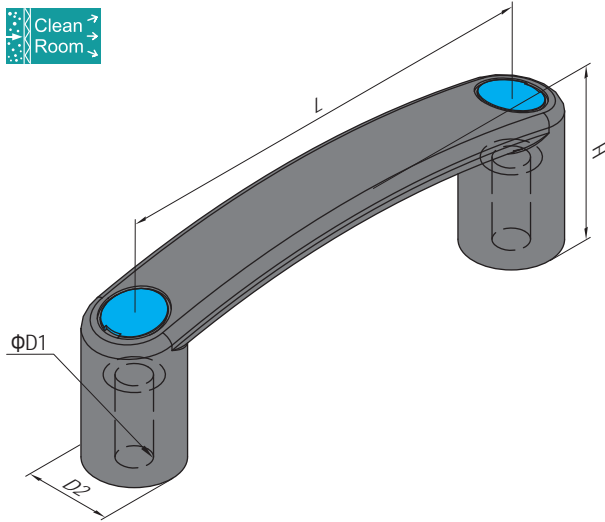

Handle





















把手

Material and Color: PA6, black

材质: 把手-尼龙6 颜色: 把手-黑色 扣盖-蓝色BE/黑色BK



LK	Fastening Set	CB	Fastening Set	CD	Fastening Set	CE	Fastening Set
	M5x25 Bolt zinc plated		M6x25 Bolt zinc plated		M8x25 Bolt zinc plated		M8x30 Bolt zinc plated
	M5 Spring Washer zinc plated		M6 T Nut nickel plated		M8 T Nut nickel plated		M8 T Nut nickel plated
	M5 Washer zinc plated						
	M5 T Nut nickel plated						

Description 产品描述	PG 型材系列	L (mm)	H (mm)	D1 (mm)	D2 (mm)	Fastening Set 紧固组件	Cap Color 扣盖颜色	Mass 重量 (g)	Part No. 订购编号
PA6 Handle-90 (pcs)/尼龙把手-90 (单个供货)	PG15/20	90	36	6.5	18			23	7.11.90.06.BE
PA6 Handle-90 (set)/尼龙把手-90 (成套供货)						2xLK		41	7.11.90.06.BE.ST
PA6 Handle-90 (pcs)/尼龙把手-90 (单个供货)								23	7.11.90.06.BK
PA6 Handle-90 (set)/尼龙把手-90 (成套供货)						2xLK		41	7.11.90.06.BK.ST
PA6 Handle-90 (pcs)/尼龙把手-90 (单个供货)	PG30	90	36	6.5	18			23	7.11.90.08.BE
PA6 Handle-90 (set)/尼龙把手-90 (成套供货)						2xCB		45	7.11.90.08.BE.ST
PA6 Handle-90 (pcs)/尼龙把手-90 (单个供货)								23	7.11.90.08.BK
PA6 Handle-90 (set)/尼龙把手-90 (成套供货)						2xCB		45	7.11.90.08.BK.ST
PA6 Handle-120 (pcs)/尼龙把手-120 (单个供货)	PG30	120	40	8.5	25			45	7.11.120.08.BE
PA6 Handle-120 (set)/尼龙把手-120 (成套供货)						2xCB		68	7.11.120.08.BE.ST
PA6 Handle-120 (pcs)/尼龙把手-120 (单个供货)								45	7.11.120.08.BK
PA6 Handle-120 (set)/尼龙把手-120 (成套供货)						2xCB		68	7.11.120.08.BK.ST
PA6 Handle-120 (pcs)/尼龙把手-120 (单个供货)	PG40	120	40	8.5	25			45	7.11.120.10.04.BE
PA6 Handle-120 (set)/尼龙把手-120 (成套供货)						2xCD		88	7.11.120.10.04.BE.ST
PA6 Handle-120 (pcs)/尼龙把手-120 (单个供货)								45	7.11.120.10.04.BK
PA6 Handle-120 (set)/尼龙把手-120 (成套供货)						2xCD		88	7.11.120.10.04.BK.ST
PA6 Handle-120 (pcs)/尼龙把手-120 (单个供货)	PG45/50/60	120	40	8.5	25			45	7.11.120.10.06.BE
PA6 Handle-120 (set)/尼龙把手-120 (成套供货)						2xCE		104	7.11.120.10.06.BE.ST
PA6 Handle-120 (pcs)/尼龙把手-120 (单个供货)								45	7.11.120.10.06.BK
PA6 Handle-120 (set)/尼龙把手-120 (成套供货)						2xCE		104	7.11.120.10.06.BK.ST

Door and Window Elements
门窗组件

Guard Wing Handle

带翼把手

Material and Color: PA6, black

材质: 把手-尼龙6 颜色: 把手-黑色 扣盖-蓝色BE/黑色BK

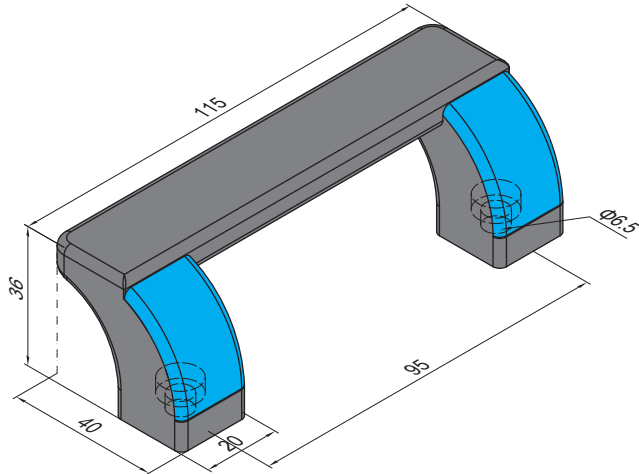
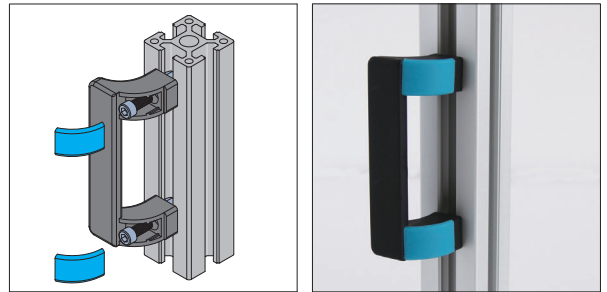

CP	Fastening Set	CQ	Fastening Set
	M6x12 Bolt zinc plated		M6x16 Bolt zinc plated
	M6 T Nut nickel plated		M6 T Nut nickel plated

Description 产品描述	PG 型材系列	Fastening Set 紧固组件	Cap Color 扣盖颜色	Mass 重量 (g)	Part No. 订购编号
Guard Wing Handle -95 (pc) 带翼把手-95 (单个供货)	PG30			70	7.12.95.08.BE
Guard Wing Handle -95 (set) 带翼把手-95 (成套供货)		2xCP		88	7.12.95.08.BE.ST
Guard Wing Handle -95 (pc) 带翼把手-95 (单个供货)				70	7.12.95.08.BK
Guard Wing Handle -95 (set) 带翼把手-95 (成套供货)		2xCP		88	7.12.95.08.BK.ST
Guard Wing Handle -95 (pc) 带翼把手-95 (单个供货)	PG40/45/50/60			70	7.12.95.10.BE
Guard Wing Handle -95 (set) 带翼把手-95 (成套供货)		2xCQ		96	7.12.95.10.BE.ST
Guard Wing Handle -95 (pc) 带翼把手-95 (单个供货)				70	7.12.95.10.BK
Guard Wing Handle -95 (set) 带翼把手-95 (成套供货)		2xCQ		96	7.12.95.10.BK.ST

Door and Window Elements
 门窗组件

 Aluminum Handle
 铝合金把手

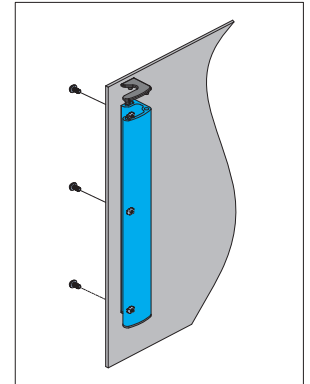
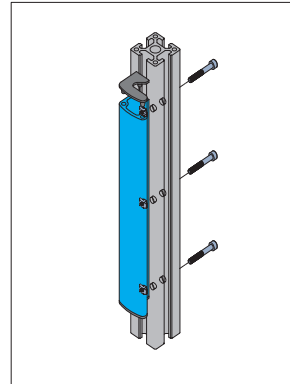
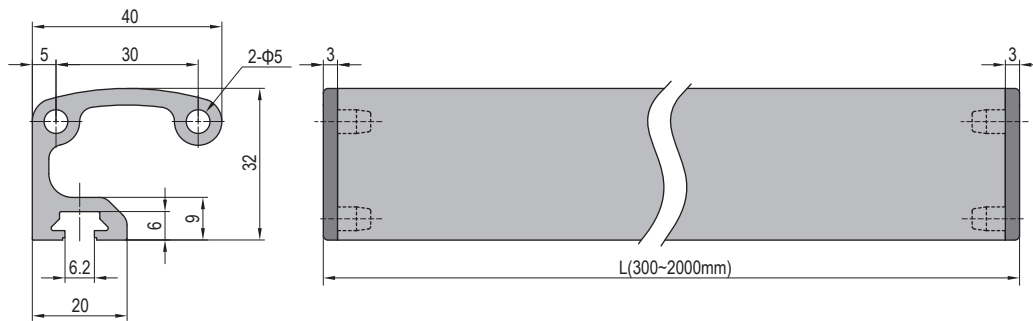
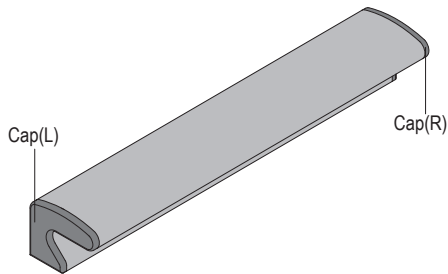
 Material: handle-aluminum Cap-ABS Cap Color: gray and black
 材质: 把手-铝合金 扣盖-ABS 颜色: 扣盖-灰色GY/黑色BK

PA	Fastening Set	PB	Fastening Set
	M5x10 Bolt zinc plated		M5x35 Bolt zinc plated
	M5 Washer zinc plated		M5 T Nut nickel plated
	M5 T Nut nickel plated		

Application 应用	Description 产品描述	Cap Color 扣盖颜色	L (mm)	Fastening Set 紧固组件	Mass 重量 (g)	Part No. 订购编号	
4mm Panel 4mm板	Aluminum Handle (pc)/铝合金把手 (单个供货)		300		216	7.13.P.GY	
	Aluminum Handle (set)/铝合金把手 (成套供货)			3×PA	224	7.13.P.GY.ST	
	Aluminum Handle (pc)/铝合金把手 (单个供货)				216	7.13.P.BK	
	Aluminum Handle (set)/铝合金把手 (成套供货)			3×PA	224	7.13.P.BK.ST	
PG40/45 	Aluminum Handle (pc)/铝合金把手 (单个供货)					216	7.13.10.GY
	Aluminum Handle (set)/铝合金把手 (成套供货)			3×PB	231	7.13.10.GY.ST	
	Aluminum Handle (pc)/铝合金把手 (单个供货)					216	7.13.10.BK
	Aluminum Handle (set)/铝合金把手 (成套供货)			3×PB	231	7.13.10.BK.ST	

Note:1. Single supply including 3 of M5 T Nuts (Reference No.2.21.06.M5).

备注: 单个供货含3个6槽M5-T形螺母(参考编号: 2.21.06.M5)。

2. The length could be customized according to customer's requirements(300~2000mm).

L值还可根据客户要求订做(300~2000mm)。

ex: 7.13.P.GY - 500

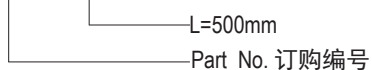

Door and Window Elements
门窗组件

Hinge
合页
Material and Color: black PA6
材质: 增强尼龙6 颜色: 黑色



Hinge-PA6
合页-增强尼龙6

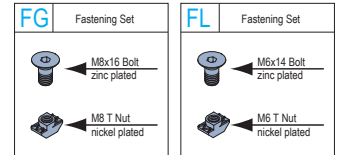
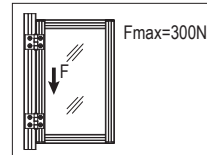
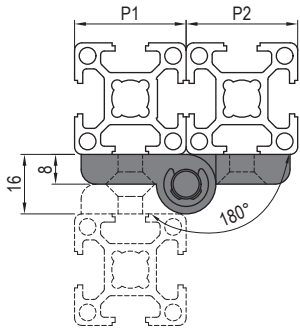
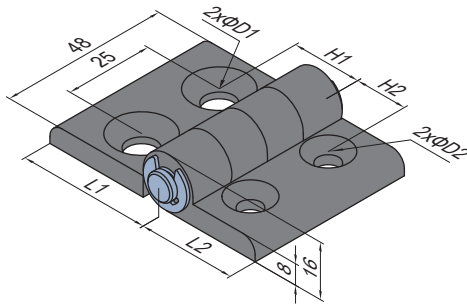

Description 产品描述	H1 (mm)	H2 (mm)	L1 (mm)	L2 (mm)	D1 (mm)	D2 (mm)	Fastening Set 紧固组件	Mass 重量 (g)	Part No. 订购编号
30/30 (pcs)/单个供货	15	15	28	28	6.5	6.5		39	7.21.30.30
30/30 (set)/成套供货							4xFL	73	7.21.30.30.ST
30/40 (pcs)/单个供货	20	15	38	28	8.5	6.5		42	7.21.30.40
30/40 (set)/成套供货							2xFG+2xFL	88	7.21.30.40.ST
30/45 (pcs)/单个供货	22.5	15	43	28	8.5	6.5		44	7.21.30.45
30/45 (set)/成套供货							2xFG+2xFL	81	7.21.30.45.ST
40/40 (pcs)/单个供货	20	20	38	38	8.5	8.5		45	7.21.40.40
40/40 (set)/成套供货							4xFG	108	7.21.40.40.ST
40/45 (pcs)/单个供货	22.5	20	43	38	8.5	8.5		47	7.21.40.45
40/45 (set)/成套供货							4xFG	110	7.21.40.45.ST
45/45 (pcs)/单个供货	22.5	22.5	43	43	8.5	8.5		49	7.21.45.45
45/45 (set)/成套供货							4xFG	112	7.21.45.45.ST



Door and Window Elements
门窗组件

Hinge
合页



Material and Color: aluminum, nature anodized
材质: 铝合金 表面处理: 本色氧化

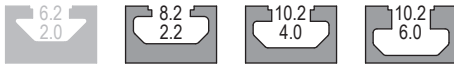

Light Hinge-Aluminum Countersink Hole
轻型合页-铝合金-沉孔

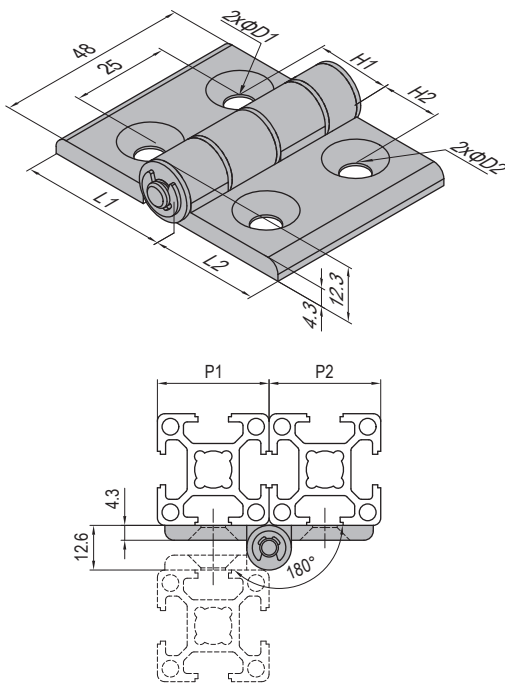
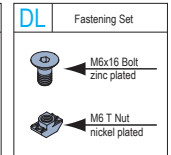
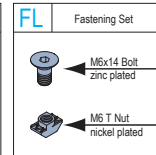
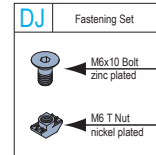
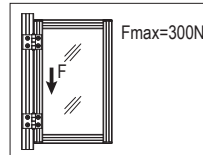

Description 产品描述	H1 (mm)	H2 (mm)	L1 (mm)	L2 (mm)	D1 (mm)	D2 (mm)	Fastening Set 紧固组件	Mass 重量 (g)	Part No. 订购编号
30/30 (pcs)/单个供货	15	15	28	28	6.5	6.5		41	7.22.30.30.E
30/30 (set)/成套供货							4xDJ	65	7.22.30.30.E.ST
30/40 (pcs)/单个供货	20	15	38	28	6.5	6.5		46	7.22.30.40.E
30/40 (set)/成套供货							2xDJ+2xFL	80	7.22.30.40.E.ST
30/45 (pcs)/单个供货	22.5	15	38	28	6.5	6.5		46	7.22.30.45.E
30/45 (set)/成套供货							2xDJ+2xDL	80	7.22.30.45.E.ST
40/40 (pcs)/单个供货	20	20	38	38	6.5	6.5		51	7.22.40.40.E
40/40 (set)/成套供货							4xFL	94	7.22.40.40.E.ST
40/45 (pcs)/单个供货	22.5	20	38	38	6.5	6.5		51	7.22.40.45.E
40/45 (set)/成套供货							2xFL+2xDL	95	7.22.40.45.E.ST
45/45 (pcs)/单个供货	22.5	22.5	38	38	6.5	6.5		51	7.22.45.45.E
45/45 (set)/成套供货							4xDL	96	7.22.45.45.E.ST

Door and Window Elements
门窗组件

Hinge
合页

Material and Color: aluminum, nature anodized
材质: 铝合金 表面处理: 光亮氧化



Hinge-Aluminum Countersink Hole
合页-铝合金-沉孔

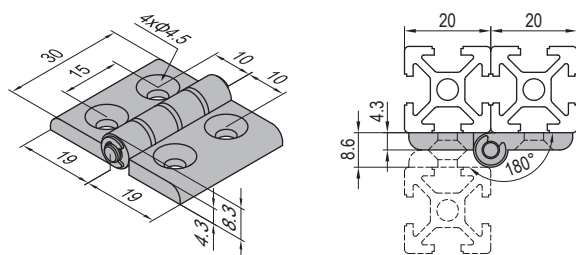

Hinge-Aluminum Countersink Hole
合页-铝合金-沉孔

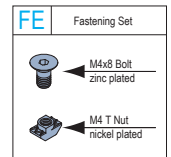
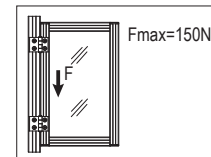
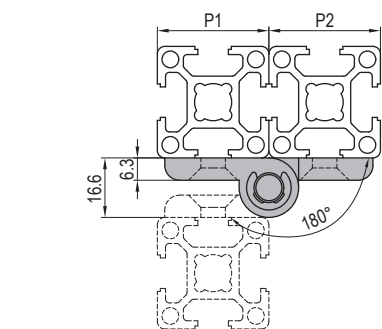
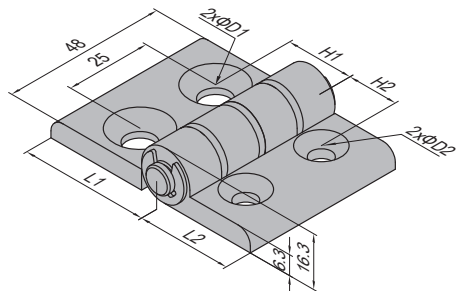

Description 产品描述	Fastening Set 紧固组件	Mass 重量 (g)	Part No. 订购编号
20/20 (pcs)/单个供货		15	7.22.20.20
20/20 (set)/成套供货	4xFE	25	7.22.20.20.ST

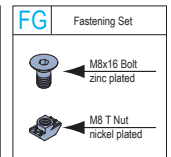
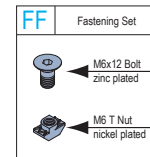
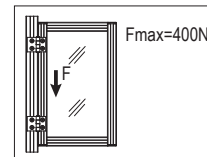

Description 产品描述	H1 (mm)	H2 (mm)	L1 (mm)	L2 (mm)	D1 (mm)	D2 (mm)	Fastening Set 紧固组件	Mass 重量 (g)	Part No. 订购编号
30/30 (pcs)/单个供货	15	15	28	28	6.5	6.5		69	7.22.30.30
30/30 (set)/成套供货							4xFF	97	7.22.30.30.ST
30/40 (pcs)/单个供货	20	15	38	28	8.5	6.5		74	7.22.30.40
30/40 (set)/成套供货							2xFF+2xFG	122	7.22.30.40.ST
30/45 (pcs)/单个供货	22.5	15	38	28	8.5	6.5		74	7.22.30.45
30/45 (set)/成套供货							2xFF+2xFG	122	7.22.30.45.ST
40/40 (pcs)/单个供货	20	20	38	38	8.5	8.5		81	7.22.40.40
40/40 (set)/成套供货							4xFG	149	7.22.40.40.ST
40/45 (pcs)/单个供货	22.5	20	38	38	8.5	8.5		81	7.22.40.45
40/45 (set)/成套供货							4xFG	149	7.22.40.45.ST
40/50 (pcs)/单个供货	25	20	43	38	8.5	8.5		84	7.22.40.50
40/50 (set)/成套供货							4xFG	152	7.22.40.50.ST
45/45 (pcs)/单个供货	22.5	22.5	38	38	8.5	8.5		81	7.22.45.45
45/45 (set)/成套供货							4xFG	149	7.22.45.45.ST
45/50 (pcs)/单个供货	25	22.5	43	38	8.5	8.5		84	7.22.45.50
45/50 (set)/成套供货							4xFG	152	7.22.45.50.ST
50/50 (pcs)/单个供货	25	25	43	43	8.5	8.5		84	7.22.50.50
50/50 (set)/成套供货							4xFG	155	7.22.50.50.ST



Door and Window Elements
门窗组件



Hinge
合页

Material and Color: aluminum, nature anodized
材质: 铝合金 表面处理: 光亮氧化

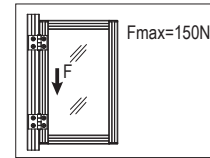
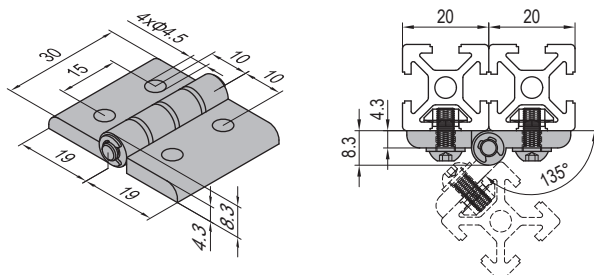

Hinge-Aluminum Through Hole
合页-铝合金-圆孔







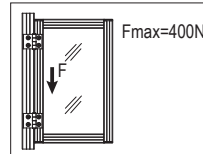
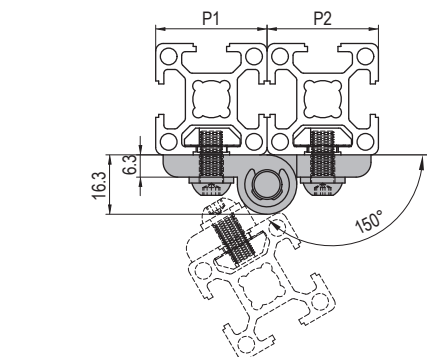
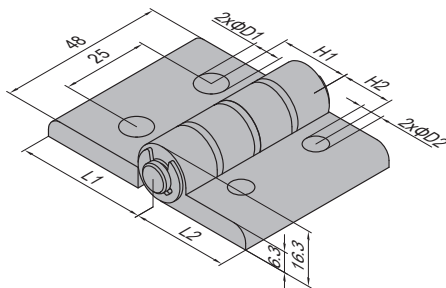

PC	Fastening Set
	M4x10 Bolt zinc plated
	M4 Washer zinc plated
	M4 T Nut nickel plated



Description 产品描述	Fastening Set 紧固组件	Mass 重量 (g)	Part No. 订购编号
20/20 (pcs)/单个供货		15	7.23.20.20
20/20 (set)/成套供货	4xPC	29	7.23.20.20.ST

Hinge-Aluminum Through Hole
合页-铝合金-圆孔



FH	Fastening Set
	M6x14 Bolt zinc plated
	M6 Washer zinc plated
	M6 T Nut nickel plated

FJ	Fastening Set
	M8x16 Bolt zinc plated
	M8 Washer zinc plated
	M8 T Nut nickel plated

FK	Fastening Set
	M8x20 Bolt zinc plated
	M8 Washer zinc plated
	M8 T Nut nickel plated

Description 产品描述	H1 (mm)	H2 (mm)	L1 (mm)	L2 (mm)	D1 (mm)	D2 (mm)	Fastening Set 紧固组件	Mass 重量 (g)	Part No. 订购编号
30/30 (pcs)/单个供货	15	15	28	28	6.5	6.5		71	7.23.30.30
30/30 (set)/成套供货							4xFH	99	7.23.30.30.ST
30/40 (pcs)/单个供货	20	15	38	28	8.5	6.5		76	7.23.30.40
30/40 (set)/成套供货							2xFH+2xFJ	124	7.23.30.40.ST
30/45 (pcs)/单个供货	22.5	15	38	28	8.5	6.5		76	7.23.30.45
30/45 (set)/成套供货							2xFH+2xFK	127	7.23.30.45.ST
40/40 (pcs)/单个供货	20	20	38	38	8.5	8.5		83	7.23.40.40
40/40 (set)/成套供货							4xFJ	151	7.23.40.40.ST
40/45 (pcs)/单个供货	22.5	20	38	38	8.5	8.5		83	7.23.40.45
40/45 (set)/成套供货							2xFJ+2xFK	156	7.23.40.45.ST
40/50 (pcs)/单个供货	25	20	43	38	8.5	8.5		87	7.23.40.50
40/50 (set)/成套供货							2xFJ+2xFK	159	7.23.40.50.ST
45/45 (pcs)/单个供货	22.5	22.5	38	38	8.5	8.5		83	7.23.45.45
45/45 (set)/成套供货							4xFK	161	7.23.45.45.ST
45/50 (pcs)/单个供货	25	22.5	43	38	8.5	8.5		87	7.23.45.50
45/50 (set)/成套供货							4xFK	167	7.23.45.50.ST
50/50 (pcs)/单个供货	25	25	43	43	8.5	8.5		87	7.23.50.50
50/50 (set)/成套供货							4xFK	164	7.23.50.50.ST



Door and Window Elements
 门窗组件

 Hinge
 合页

 Material and Color: aluminum, nature anodized
 材质: 铝合金 表面处理: 光亮氧化

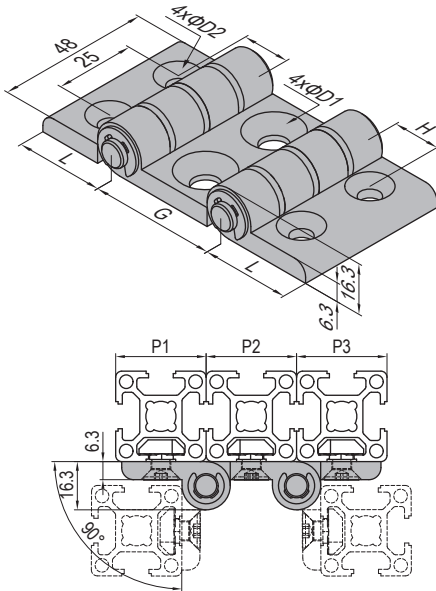
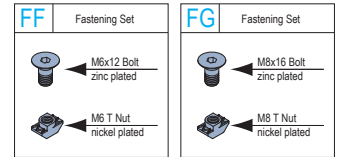
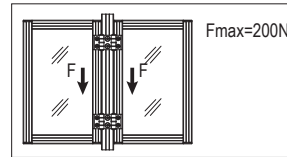
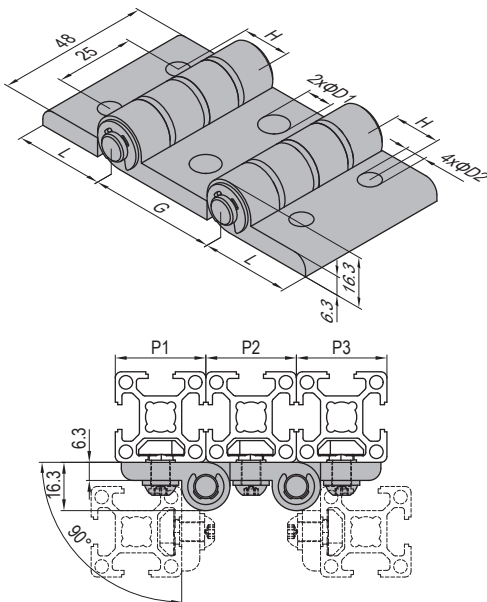
 Hinge-Aluminum Countersink Hole
 合页-铝合金-沉孔

 Hinge-Aluminum Through Hole
 合页-铝合金-圆孔

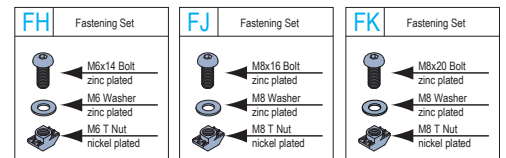
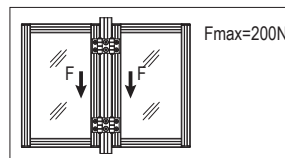
Description 产品描述	G (mm)	H (mm)	L (mm)	D1 (mm)	D2 (mm)	Fastening Set 紧固组件	Mass 重量 (g)	Part No. 订购编号
30/30/30 (pcs)/单个供货	30	15	28	6.5	6.5		98	7.24.30.30.30
30/30/30 (set)/成套供货						6xFF	140	7.24.30.30.30.ST
30/40/30 (pcs)/单个供货	40	15	28	8.5	6.5		104	7.24.30.40.30
30/40/30 (set)/成套供货						4xFF+2xFG	166	7.24.30.40.30.ST
30/45/30 (pcs)/单个供货	45	15	28	8.5	6.5		108	7.24.30.45.30
30/45/30 (set)/成套供货						4xFF+2xFG	170	7.24.30.45.30.ST
40/40/40 (pcs)/单个供货	40	20	38	8.5	8.5		115	7.24.40.40.40
40/40/40 (set)/成套供货						6xFG	217	7.24.40.40.40.ST
40/45/40 (pcs)/单个供货	45	20	38	8.5	8.5		119	7.24.40.45.40
40/45/40 (set)/成套供货						6xFG	221	7.24.40.45.40.ST
45/45/45 (pcs)/单个供货	45	22.5	38	8.5	8.5		119	7.24.45.45.45
45/45/45 (set)/成套供货						6xFG	221	7.24.45.45.45.ST



Description 产品描述	G (mm)	H (mm)	L (mm)	D1 (mm)	D2 (mm)	Fastening Set 紧固组件	Mass 重量 (g)	Part No. 订购编号
30/30/30 (pcs)/单个供货	30	15	28	6.5	6.5		100	7.25.30.30.30
30/30/30 (set)/成套供货						6xFH	142	7.25.30.30.30.ST
30/40/30 (pcs)/单个供货	40	15	28	8.5	6.5		107	7.25.30.40.30
30/40/30 (set)/成套供货						4xFH+2xFJ	169	7.25.30.40.30.ST
30/45/30 (pcs)/单个供货	45	15	28	8.5	6.5		111	7.25.30.45.30
30/45/30 (set)/成套供货						4xFH+2xFK	175	7.25.30.45.30.ST
40/40/40 (pcs)/单个供货	40	20	38	8.5	8.5		121	7.25.40.40.40
40/40/40 (set)/成套供货						6xFJ	213	7.25.40.40.40.ST
40/45/40 (pcs)/单个供货	45	20	38	8.5	8.5		125	7.25.40.45.40
40/45/40 (set)/成套供货						4xFJ+2xFK	230	7.25.40.45.40.ST
45/45/45 (pcs)/单个供货	45	22.5	38	8.5	8.5		125	7.25.45.45.45
45/45/45 (set)/成套供货						6xFK	245	7.25.45.45.45.ST



Door and Window Elements
 门窗组件

Hinge

合页

Material and Color: aluminum, nature anodized

材质: 铝合金 表面处理: 光亮氧化

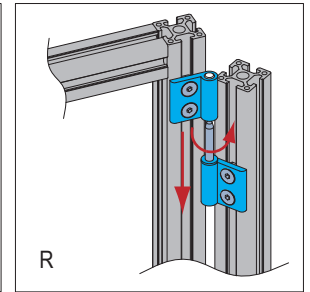
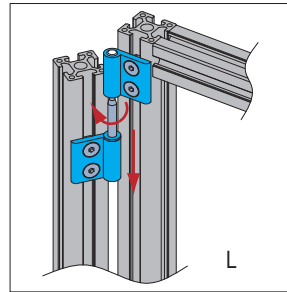
 Hinge-AI Removable Hinge-L
 合页-插拔合页-左开

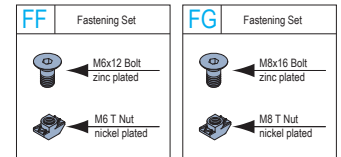
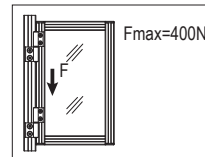
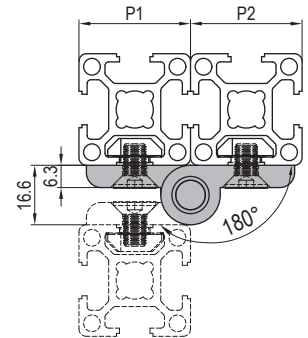
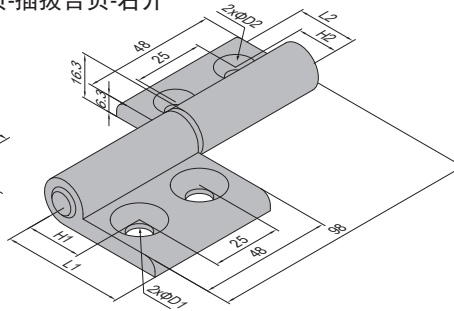
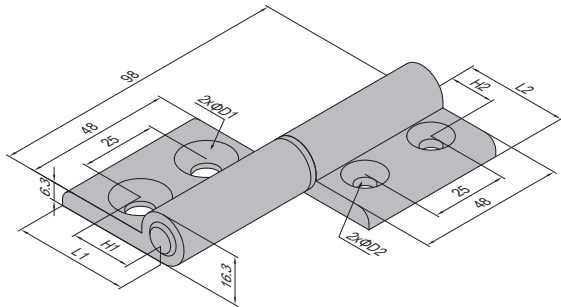
 Hinge-AI Removable Hinge-R
 合页-插拔合页-右开

Description 产品描述	H1 (mm)	H2 (mm)	L1 (mm)	L2 (mm)	D1 (mm)	D2 (mm)	Fastening Set 紧固组件	Mass 重量 (g)	Part No.(L) 订购编号(左开)	Part No.(R) 订购编号(右开)
30/30 (pcs)/单个供货	15	15	28	28	6.5	6.5		105	7.26.30.30	7.27.30.30
30/30 (set)/成套供货							4xFF	133	7.26.30.30.ST	7.27.30.30.ST
30/40 (pcs)/单个供货	20	15	38	28	8.5	6.5		110	7.26.30.40	7.27.30.40
30/40 (set)/成套供货							2xFF+2xFG	158	7.26.30.40.ST	7.27.30.40.ST
30/45 (pcs)/单个供货	22.5	15	38	28	8.5	6.5		110	7.26.30.45	7.27.30.45
30/45 (set)/成套供货							2xFF+2xFG	158	7.26.30.45.ST	7.27.30.45.ST
40/40 (pcs)/单个供货	20	20	38	38	8.5	8.5		118	7.26.40.40	7.27.40.40
40/40 (set)/成套供货							4xFG	186	7.26.40.40.ST	7.27.40.40.ST
40/45 (pcs)/单个供货	22.5	20	38	38	8.5	8.5		118	7.26.40.45	7.27.40.45
40/45 (set)/成套供货							4xFG	186	7.26.40.45.ST	7.27.40.45.ST
40/50 (pcs)/单个供货	25	20	43	38	8.5	8.5		121	7.26.40.50	7.27.40.50
40/50 (set)/成套供货							4xFG	189	7.26.40.50.ST	7.27.40.50.ST
45/45 (pcs)/单个供货	22.5	22.5	38	38	8.5	8.5		118	7.26.45.45	7.27.45.45
45/45 (set)/成套供货							4xFG	186	7.26.45.45.ST	7.27.45.45.ST
45/50 (pcs)/单个供货	25	22.5	43	38	8.5	8.5		121	7.26.45.50	7.27.45.50
45/50 (set)/成套供货							4xFG	189	7.26.45.50.ST	7.27.45.50.ST
50/50 (pcs)/单个供货	25	25	43	43	8.5	8.5		121	7.26.50.50	7.27.50.50
50/50 (set)/成套供货							4xFG	192	7.26.50.50.ST	7.27.50.50.ST



Door and Window Elements
门窗组件

Hinge
合页

Material and Color: aluminum, nature anodized
材质: 铝合金 表面处理: 光亮氧化

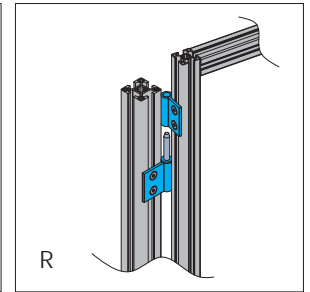
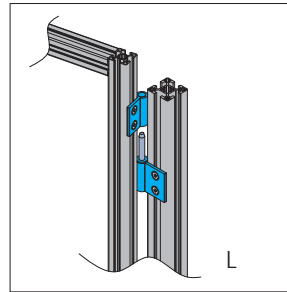

Hinge-Light AI Removable Hinge-L
合页-轻型插拔合页-左开

New!

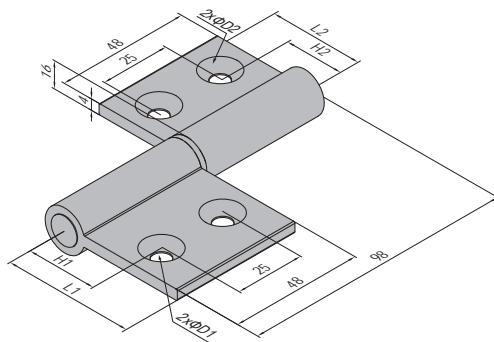

Hinge-Light AI Removable Hinge-R
合页-轻型插拔合页-右开

New!

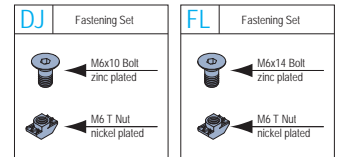
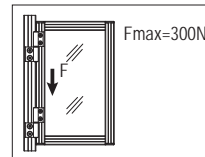
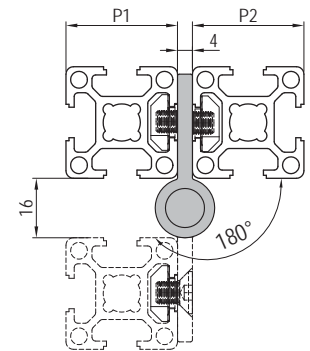
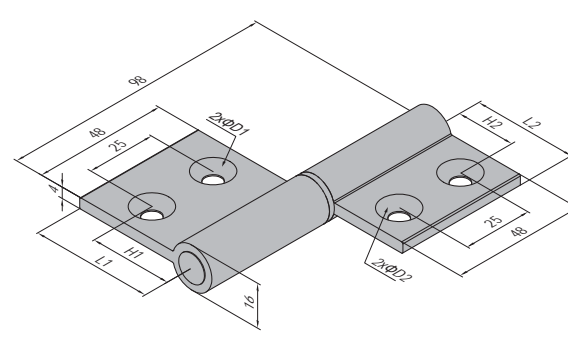

Description 产品描述	H1 (mm)	H2 (mm)	L1 (mm)	L2 (mm)	D1 (mm)	D2 (mm)	Fastening Set 紧固组件	Mass 重量 (g)	Part No.(L) 订购编号(左开)	Part No.(R) 订购编号(右开)
30/30 (pcs)/单个供货	23	23	36	36	6.5	6.5		105	7.26.30.30.E	7.27.30.30.E
30/30 (set)/成套供货							4xDJ	133	7.26.30.30.E.ST	7.27.30.30.E.ST
30/40 (pcs)/单个供货	28	23	46	36	6.5	6.5		111	7.26.30.40.E	7.27.30.40.E
30/40 (set)/成套供货							2xDJ+2xFL	147	7.26.30.40.E.ST	7.27.30.40.E.ST
40/40 (pcs)/单个供货	28	28	46	46	6.5	6.5		117	7.26.40.40.E	7.27.40.40.E
40/40 (set)/成套供货							4xFL	161	7.26.40.40.E.ST	7.27.40.40.E.ST







Door and Window Elements
门窗组件

Hinge
合页
Material and Color: aluminum, nature anodized
材质: 铝合金 表面处理: 阳极氧化

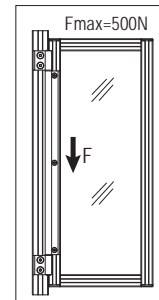
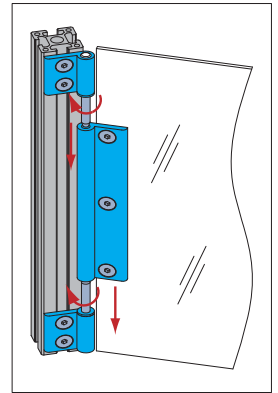
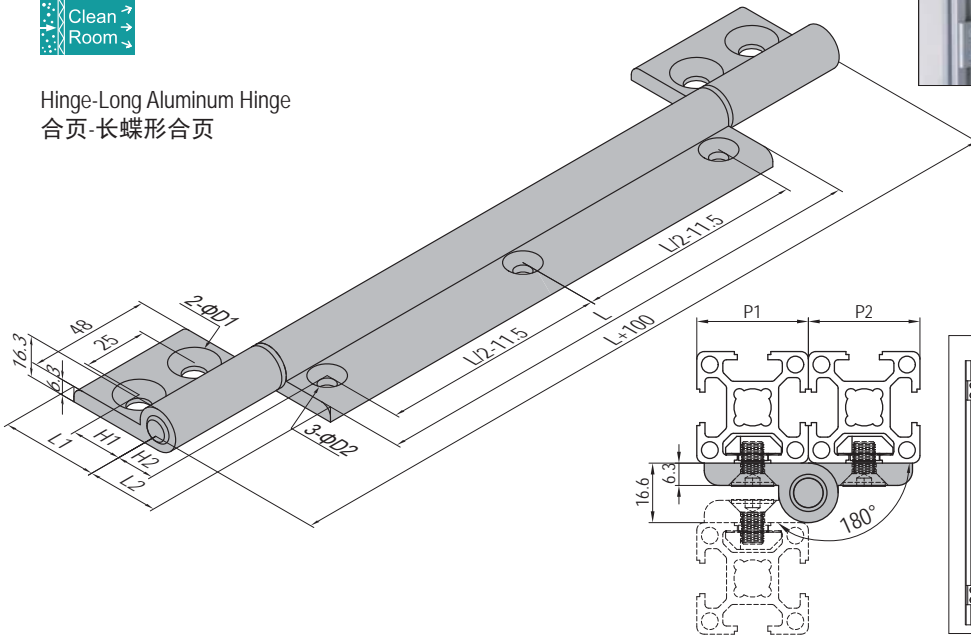

Hinge-Long Aluminum Hinge
合页-长蝶形合页



FF	Fastening Set	FG	Fastening Set
	M6x12 Bolt zinc plated		M8x16 Bolt zinc plated
	M6 T Nut nickel plated		M8 T Nut nickel plated

Description 产品描述	H1 (mm)	H2 (mm)	L1 (mm)	L2 (mm)	D1 (mm)	D2 (mm)	L (mm)	Fastening Set 紧固组件	Mass 重量 (g)	Part No. 订购编号
30/30 (pcs)/单个供货	15	15	28	28	6.5	6.5	500		515	7.28.30.30
30/30 (set)/成套供货								7×FF	571	7.28.30.30.ST
30/40 (pcs)/单个供货	20	15	38	28	8.5	6.5			525	7.28.30.40
30/40 (set)/成套供货								3×FF+4×FG	617	7.28.30.40.ST
30/45 (pcs)/单个供货	22.5	15	38	28	8.5	6.5			525	7.28.30.45
30/45 (set)/成套供货								3×FF+4×FG	617	7.28.30.45.ST
40/40 (pcs)/单个供货	20	20	38	38	8.5	8.5			605	7.28.40.40
40/40 (set)/成套供货								7×FG	724	7.28.40.40.ST
40/45 (pcs)/单个供货	22.5	20	38	38	8.5	8.5			605	7.28.40.45
40/45 (set)/成套供货								7×FG	724	7.28.40.45.ST
45/45 (pcs)/单个供货	22.5	22.5	38	38	8.5	8.5			605	7.28.45.45
45/45 (set)/成套供货								7×FG	724	7.28.45.45.ST

Note: The length could be customized according to customer's requirements(100~1000mm).
备注: L值还可根据客户要求订做(100~1000mm)。

ex: 7.28.30.30 - 1000

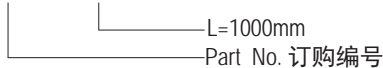

Door and Window Elements

门窗组件

Lock
门锁



Compact metal lock with self-locking design.

设计简洁，有自锁功能。

Material and Color: diecast zinc, black electrophoresis

材质：压铸锌 颜色：黑色电泳

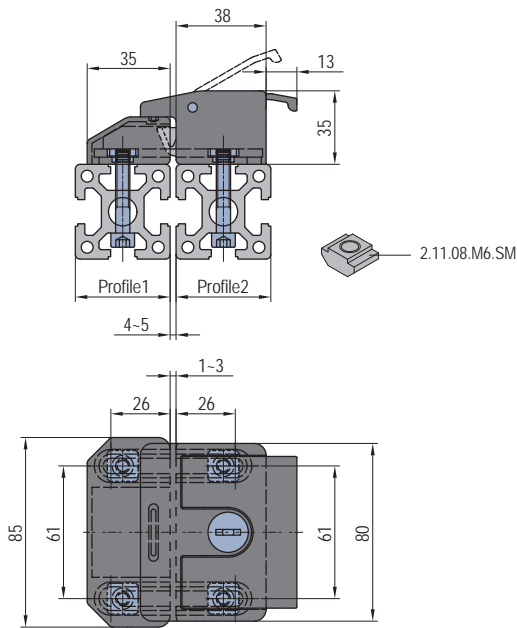
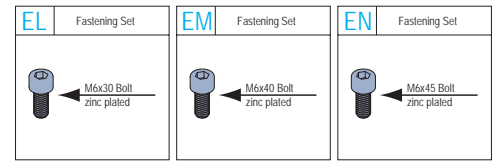
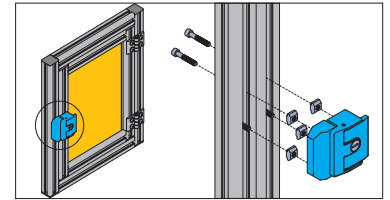

Description 产品描述	Profile 1 型材1	Profile 2 型材2	Fastening Set 紧固组件	Mass 重量 (g)	Part No. 订购编号
Lock (pcs) 门锁 (单个供货)				690	7.31
Lock-3030 (set) 门锁-3030 (成套供货)	PG30 30系列	PG30 30系列	4xEL	719	7.31.30.30
Lock-4030 (set) 门锁-4030 (成套供货)	PG40 40系列	PG30 30系列	2xEL 2xEM	724	7.31.40.30
Lock-4040 (set) 门锁-4040 (成套供货)	PG40 40系列	PG40 40系列	4xEM	728	7.31.40.40
Lock-4530 (set) 门锁-4530 (成套供货)	PG45 45系列	PG30 30系列	2xEL 2xEN	726	7.31.45.30
Lock-4540 (set) 门锁-4540 (成套供货)	PG45 45系列	PG40 40系列	2xEM 2xEN	731	7.31.45.40
Lock-4545 (set) 门锁-4545 (成套供货)	PG45 45系列	PG45 45系列	4xEN	733	7.31.45.45

Note: Including special nuts.
备注：含门锁专用螺母。



Door and Window Elements
门窗组件

Lock
门锁



Material and Color: zinc alloy, polish finish
材质: 锌合金 表面处理: 光面



L Lock
L形门锁

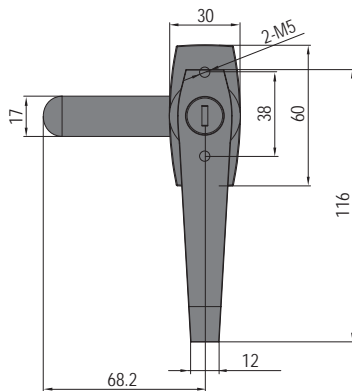
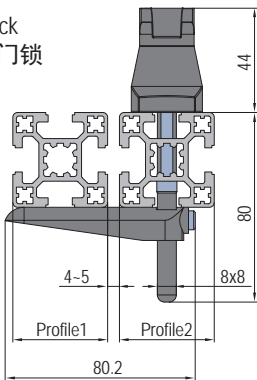

T Lock
T形门锁

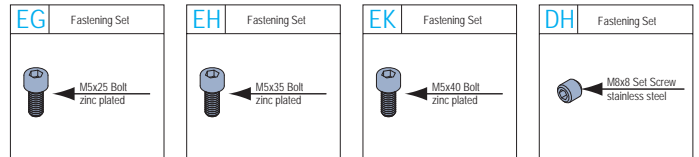
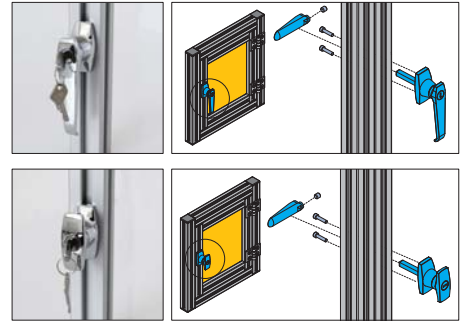
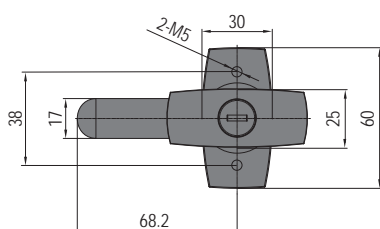
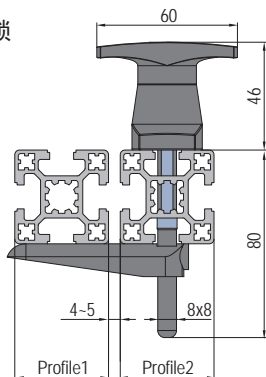

Description 产品描述	Profile 1 型材1	Profile 2 型材2	Fastening Set 紧固组件	Mass 重量 (g)	Part No. 订购编号
L Lock-3030 L形门锁-3030	PG30 30系列	PG30 30系列	DH+2xEG	290	7.32.30.30
L Lock-4030 L形门锁-4030	PG40 40系列	PG30 30系列			7.32.40.30
L Lock-4530 L形门锁-4530	PG45 45系列	PG30 30系列			7.32.45.30
L Lock-4040 L形门锁-4040	PG40 40系列	PG40 40系列	DH+2xEH	294	7.32.40.40
L Lock-4540 L形门锁-4540	PG45 45系列	PG40 40系列			7.32.45.40
L Lock-5040 L形门锁-5040	PG50 50系列	PG40 40系列			7.32.50.40
L Lock-4545 L形门锁-4545	PG45 45系列	PG45 45系列	DH+2xEK	296	7.32.45.45
L Lock-5045 L形门锁-5045	PG50 50系列	PG45 45系列			7.32.50.45
L Lock-5050 L形门锁-5050	PG50 50系列	PG50 50系列			7.32.50.50
T Lock-3030 T形门锁-3030	PG30 30系列	PG30 30系列	DH+2xEG	270	7.33.30.30
T Lock-4030 T形门锁-4030	PG40 40系列	PG30 30系列			7.33.40.30
T Lock-4530 T形门锁-4530	PG45 45系列	PG30 30系列			7.33.45.30
T Lock-4040 T形门锁-4040	PG40 40系列	PG40 40系列	DH+2xEH	274	7.33.40.40
T Lock-4540 T形门锁-4540	PG45 45系列	PG40 40系列			7.33.45.40
T Lock-5040 T形门锁-5040	PG50 50系列	PG40 40系列			7.33.50.40
T Lock-4545 T形门锁-4545	PG45 45系列	PG45 45系列	DH+2xEK	276	7.33.45.45
T Lock-5045 T形门锁-5045	PG50 50系列	PG45 45系列			7.33.50.45
T Lock-5050 T形门锁-5050	PG50 50系列	PG50 50系列			7.33.50.50



Door and Window Elements
门窗组件









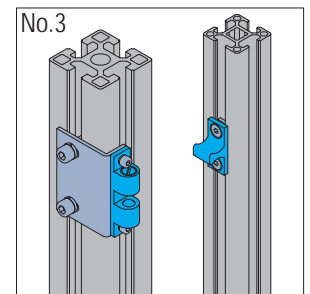
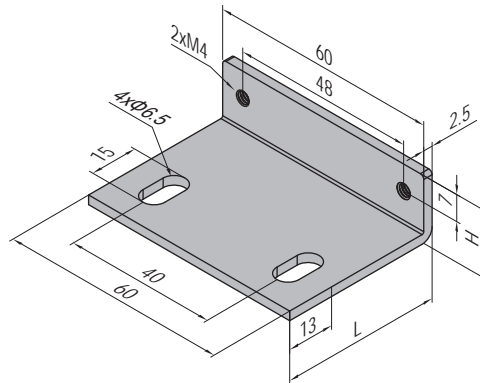
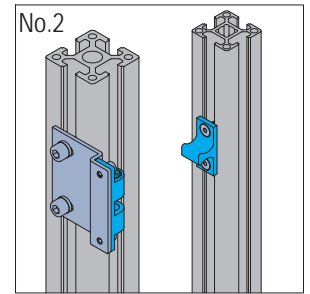
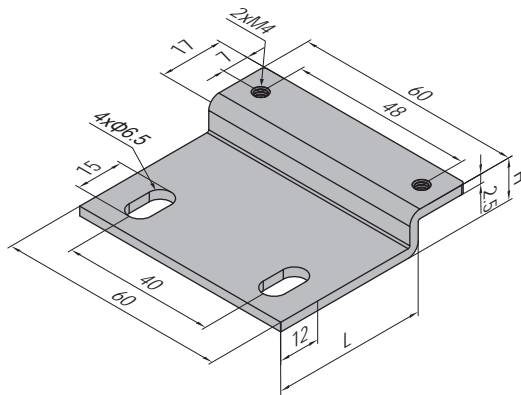
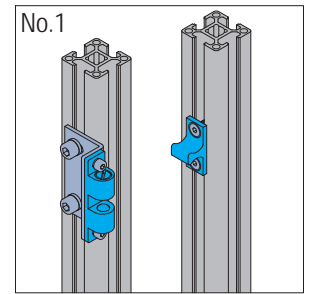
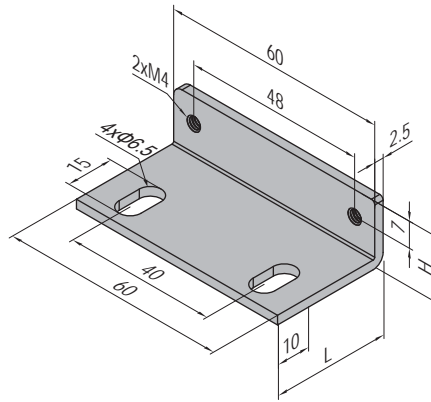
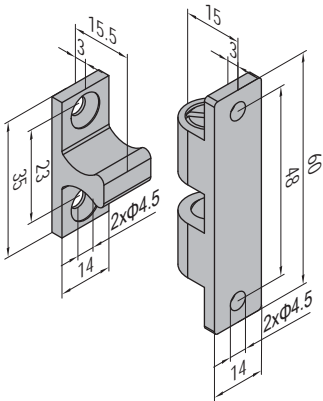





Magnet Catch
门碰

Material: Magnet Catch-aluminum alloy, hard oxidation anodized
Connectors-zinc plated steel

材质: 门碰-铝合金硬质氧化
连接件-碳钢镀锌

Note: When the magnet catch is installed on the lower door frame, the door should be more than 400mm.
门碰在底梁安装时, 门的尺寸需大于400mm。



CF	PF	CJ	CK	CN
Fastening Set	Fastening Set	Fastening Set	Fastening Set	Fastening Set
 M4x10 Bolt zinc plated  M4 T Nut nickel plated	 M4x8 Bolt zinc plated  M4 Spring Washer zinc plated  M4 Washer zinc plated	 M6x10 Bolt zinc plated  M6 Spring Washer zinc plated  M6 T Nut nickel plated	 M6x14 Bolt zinc plated  M6 Spring Washer zinc plated  M6 T Nut nickel plated	 M6x16 Bolt zinc plated  M6 Spring Washer zinc plated  M6 T Nut nickel plated

Description 产品描述	L (mm)	H (mm)	Fastening Set 紧固组件	Mass 重量 (g)	Part No. 订购编号
Magnet Catch-14 (pcs) 门碰-14 (单个供货)				26	7.41.14
Magnet Catch-14 (Profile 3030 for Door, Profile 3030 for Doorframe set No.1) 门碰-14 (3030型材做门, 3030型材做门框 成套供货 No.1)	31	17	2xCF+2xPF+2xCJ	130	7.41.14.3030.ST
Magnet Catch-14 (Profile 3030 for Door, Profile 4040 for Doorframe set No.2) 门碰-14 (3030型材做门, 4040型材做门框 成套供货 No.2)	41	11	2xCF+2xPF+2xCK	139	7.41.14.3040.ST
Magnet Catch-14 (Profile 3030 for Door, Profile 4545 for Doorframe set No.3) 门碰-14 (3030型材做门, 4545型材做门框 成套供货 No.3)	42	14	2xCF+2xPF+2xCN	145	7.41.14.3045.ST



Door and Window Elements
 门窗组件

 Magnet Catch
 门碰

Material: Magnet Catch-aluminum alloy, hard oxidation anodized
 Connector-zinc plated steel
 (Material for Connector 4080 is aluminum alloy)

材质: 门碰-铝合金硬质氧化 连接件-碳钢镀锌
 (4080连接件材质为铝合金)

Note: When the magnet catch is installed on the lower door frame, the door should be more than 400mm.
 门碰在底梁安装时, 门的尺寸需大于400mm.

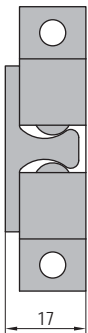
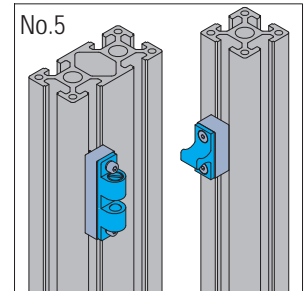
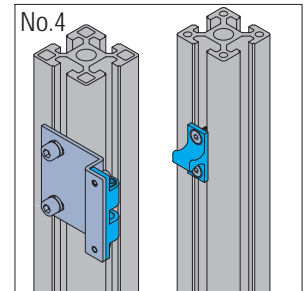
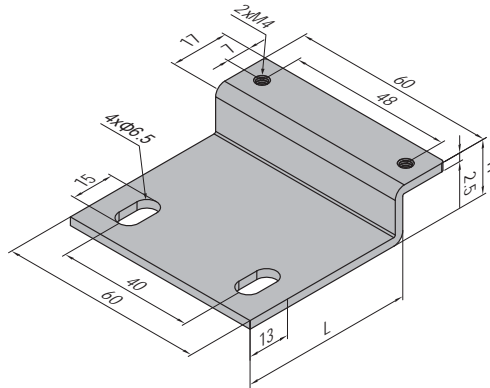
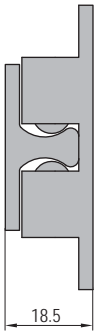
 Tighten Status 1
 锁紧状态1

 Tighten Status 2
 锁紧状态2

CG	Fastening Set	PF	Fastening Set	CK	Fastening Set	CL	Fastening Set	CY	Fastening Set	CN	Fastening Set
	M4x14 Bolt zinc plated		M4x8 Bolt zinc plated		M6x14 Bolt zinc plated		M4x25 Bolt zinc plated		M4x20 Bolt zinc plated		M6x16 Bolt zinc plated
			M4 Spring Washer zinc plated		M6 Spring Washer zinc plated		M4 Spring Washer zinc plated				M6 Spring Washer zinc plated
			M4 Washer zinc plated		M6 T Nut nickel plated		M4 T Nut nickel plated		M4 T Nut nickel plated		M6 T Nut nickel plated

Description 产品描述	L (mm)	H (mm)	Fastening Set 紧固组件	Mass 重量 (g)	Part No. 订购编号
Magnet Catch-14 (Profile 4040 for Door, Profile 4040 for Doorframe set No.1) 门碰-14 (4040型材做门, 4040型材做门框 成套供货 No.1)	45	17	2xCG+2xPF+2xCK	147	7.41.14.4040.ST
Magnet Catch-14 (Profile 4040 for Door, Profile 4545 for Doorframe set No.4) 门碰-14 (4040型材做门, 4545型材做门框 成套供货 No.4)	51	16	2xCG+2xPF+2xCN	151	7.41.14.4045.ST
Magnet Catch-14 (Profile 4040 for Door, Profile 4080 for Doorframe set No.5) 门碰-14 (4040型材做门, 4080型材做门框 成套供货 No.5)			2xCL+2xCY	255	7.41.14.4080.ST
Magnet Catch-14 (Profile 4040 for Door, Profile 5050 for Doorframe set No.4) 门碰-14 (4040型材做门, 5050型材做门框 成套供货 No.4)	51	11	2xCG+2xPF+2xCN	145.5	7.41.14.4050.ST
Magnet Catch-14 (Profile 4545 for Door, Profile 4545 for Doorframe set No.1) 门碰-14 (4545型材做门, 4545型材做门框 成套供货 No.1)	45	17	2xCG+2xPF+2xCN	151	7.41.14.4545.ST
Magnet Catch-14 (Profile 4545 for Door, Profile 5050 for Doorframe set No.4) 门碰-14 (4545型材做门, 5050型材做门框 成套供货 No.4)	51	16	2xCG+2xPF+2xCN	151	7.41.14.4550.ST
Magnet Catch-14 (Profile 5050 for Door, Profile 5050 for Doorframe set No.1) 门碰-14 (5050型材做门, 5050型材做门框 成套供货 No.1)	50	17	2xCG+2xPF+2xCN	149	7.41.14.5050.ST



Door and Window Elements
门窗组件

Door lock
门搭扣

Material: DoorLock-black electrophoresis

Block-diecast aluminum, black electrophoresis

材质: 固定块-压铸铝合金 表面处理: 搭扣-黑色电泳 固定块-黑色电泳

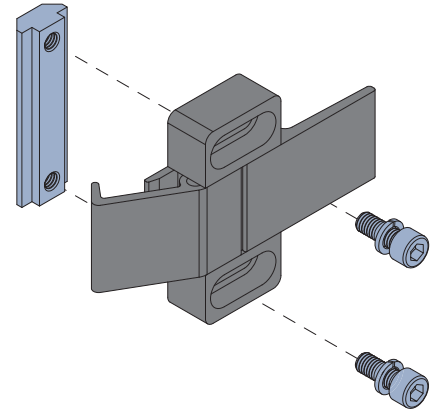
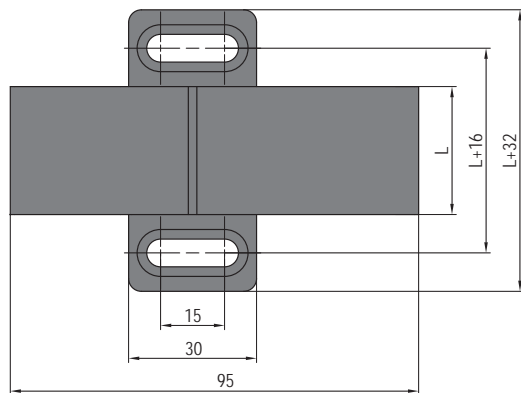
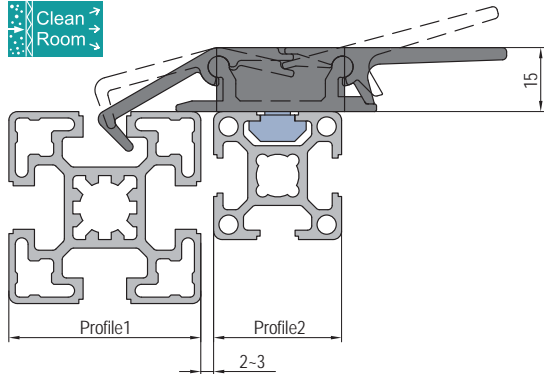

Description 产品描述	Profile 1 型材1	Profile 2 型材2	L (mm)	Fastening Set 紧固组件	Mass 重量 (g)	Part No. 订购编号
Door Locks-3040 门搭扣-3040	PG40 40系列	PG30 30系列	30	2xCU+1xEP	115	7.42.30.3040
Door Locks-3045 门搭扣-3045	PG45 45系列	PG30 30系列			115	7.42.30.3045
Door Locks-4040 门搭扣-4040	PG40 40系列	PG40 40系列			140	7.42.30.4040
Door Locks-4045 门搭扣-4045	PG45 45系列	PG40 40系列	50	2xCU+1xEP	185	7.42.30.4045
Door Locks-4545 门搭扣-4545	PG45 45系列	PG45 45系列	50	2xCV+1xEP	187	7.42.30.4545

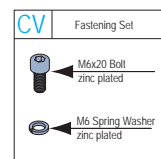
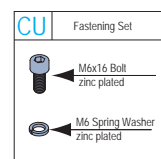

Note: including block and special nut.

备注: 含固定块和门搭扣专用螺母。

2 The length could be customized according to customer's requirement(30-80mm)

L值还可根据客户要求订做(30-80mm)。

ex: 7.42.30.3040 - 50



Door and Window Elements
门窗组件

Sliding Door Profile
拉门滑道

The sliding door profile clips into strut profiles and is suitable for light-weight sliding doors.
拉门滑道可置入型材槽口内，只适用于轻载荷板类做水平拉门的情况。

Material and Colors: Sliding door profile-PVC, grey PE Bar-HD-PE, Nature.

材质：拉门滑道-PVC PE棒-HD 颜色：拉门滑道-灰色 PE棒-PE本色

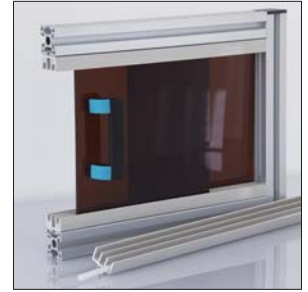

Sliding Door Profile-8
拉门滑道-8

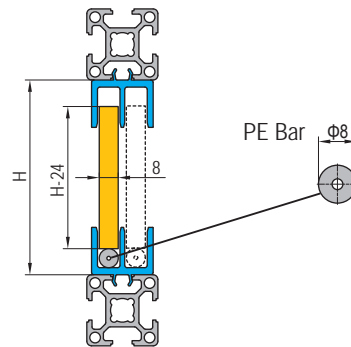
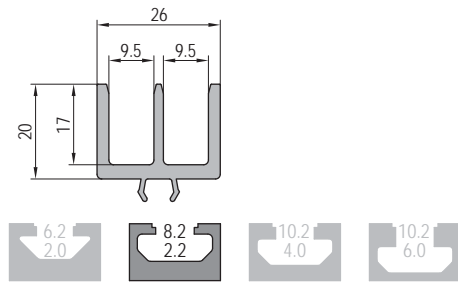

Sliding Door Profile-10-4
拉门滑道-10-4

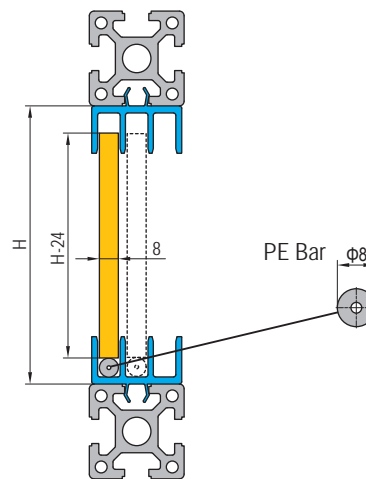
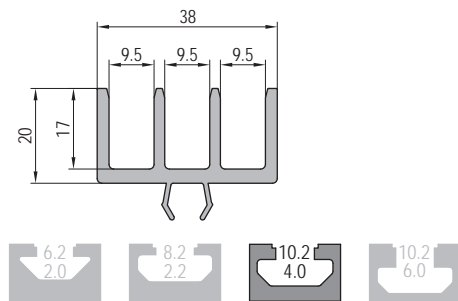

Description 产品描述	PG 型材系列	Mass 重量 (g/m)	Delivery Length 供货长度	Part No. 订购编号
Sliding Door Profile-8 拉门滑道-8	PG30	330	3000mm/bar	7.51.08
Sliding Door Profile-8 (Including 2 pcs PE bar) 拉门滑道-8 (含两个PE棒)		390		7.51.08.ST
Sliding Door Profile-10-4 拉门滑道-10-4	PG40	450		7.51.10.04
Sliding Door Profile-10-4 (Including 2 pcs PE bar) 拉门滑道-10-4 (含两个PE棒)		510		7.51.10.04.02.ST
Sliding Door Profile-10-4 (Including 3 pcs PE bar) 拉门滑道-10-4 (含三个PE棒)		540		7.51.10.04.03.ST

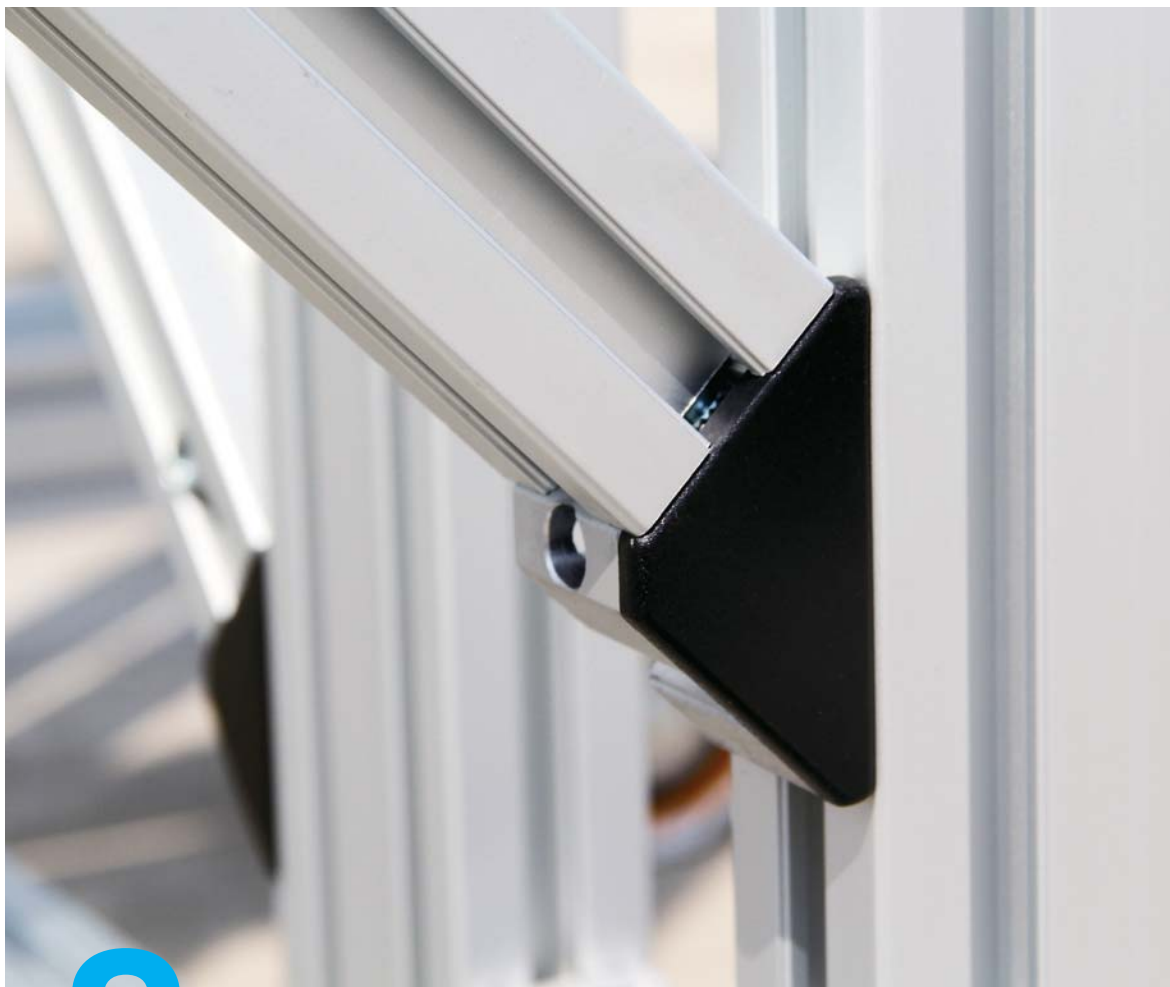

8.11-8.61

Suspended Glider
挂钩

Swivel Angle Plate
角度调节板

Potential Equaliser Nut
导静电螺母

Joint
枢轴

Frame Joint
加强筋

Mounting Adaptor for Roller
辊筒固定块

Telescope Unit
伸缩装置

8

Additional Accessories 其它附件



P. 8-02



P. 8-03



P. 8-04



P. 8-05



P. 8-07



P. 8-08



P. 8-09



Additional Accessories
其他附件

Suspended Glider
挂钩

The glider can be suspended in profile slot.

挂钩可悬挂在型材槽内。

Material and Color: glider-PA6+GF30, black hook-zinc plated steel

材质: 滑块-增强尼龙6+玻璃纤维30 滑块-黑色 挂钩-碳钢镀锌

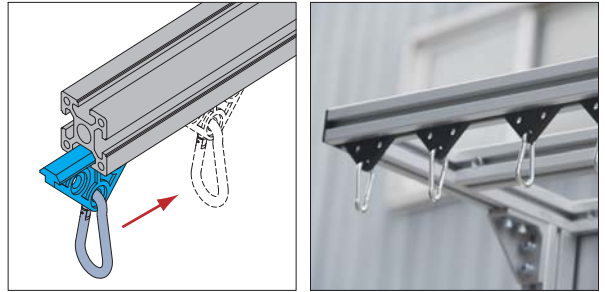

Suspended Glider-8
挂钩-8

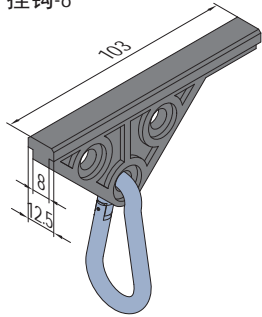

Description 产品描述	Static Load 静态承重 (N)	Mass 重量 (g)	Part No. 订购编号
Suspended Glider-8 挂钩-8	200	48	8.11.08

Suspended Glider -10
挂钩-10

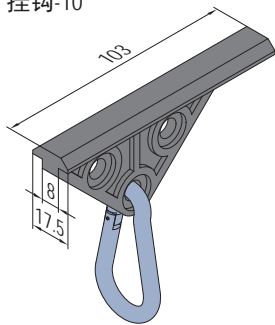

Description 产品描述	Static Load 静态承重 (N)	Mass 重量 (g)	Part No. 订购编号
Suspended Glider-10 挂钩-10	200	48	8.11.10

Additional Accessories
其他附件

Swivel Angle Plate

角度调节板

Infinitely variable adjusting of inclination with swivel angle.

角度调节板可实现型材间最大角度的调节。

Material and Color: steel, black electrophoresis

材质: 碳钢 颜色: 黑色电泳

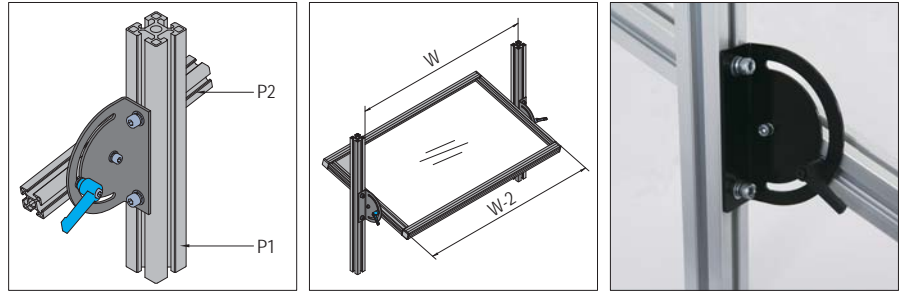

Swivel Angle Plate-PG30

角度调节板-30系列

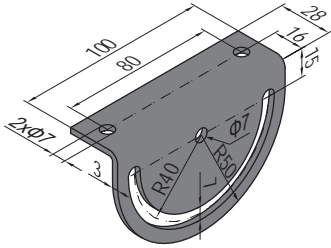

Swivel Angle Plate-PG40/45

角度调节板-40/45系列

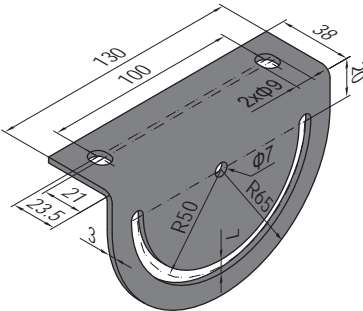

FR	FT	FV	FW	R
Fastening Set	Fastening Set	Fastening Set	Fastening Set	Fastening Set
M6x12 Adjustable Handle plastic coated, black	M6x12 Bolt zinc plated	M8x16 Bolt zinc plated	M6x16 Bolt zinc plated	M6x12 Bolt zinc plated
M6 Washer zinc plated	M6 Washer zinc plated	M8 Washer zinc plated	M6 Washer zinc plated	M6 Washer zinc plated
M6 Pre-set Nut nickel plated	M6 Pre-set Nut nickel plated	M8 T Nut nickel plated	M6 Pre-set Nut nickel plated	M6 T Nut nickel plated

Description 产品描述	P1	P2	Fastening Set 紧固组件	Mass 重量 (g)	Part No. 订购编号
Swivel Angle Plate-PG30 (pcs) 角度调节板-30系列(单个供货)				160	8.21.30
Swivel Angle Plate-PG30 (set) 角度调节板-30系列(成套供货)	PG30 30系列	PG30 30系列	1xFR+1xFT+2xR	270	8.21.30.ST
Swivel Angle Plate-PG40/45 (pcs) 角度调节板-40/45系列(单个供货)				288	8.21.40
Swivel Angle Plate-PG40/45-PG30 (set) 角度调节板-40/45系列-30系列(成套供货)	PG40/45 40/45系列	PG30 30系列	1xFR+1xFT+2xFV	420	8.21.40.30.ST
Swivel Angle Plate-PG40/45-PG40/45 (set) 角度调节板-40/45系列-40/45系列(成套供货)	PG40/45 40/45系列	PG40/45 40/45系列	1xFR+2xFV+1xFW	443	8.21.40.40.ST

Additional Accessories
其他附件

Potential Equaliser Nut
导静电螺母

Potential Equaliser Nut penetrates the oxide film of the profiles at the connection to conduct the static inside of the profiles and to average the potential.

导静电螺母可以在连接处刺透两端型材的氧化膜，从而导通型材内部静电，实现平均电势的作用。

Material: zinc alloy
材质：锌合金

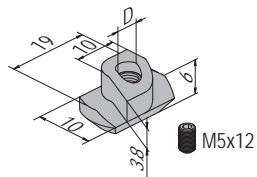
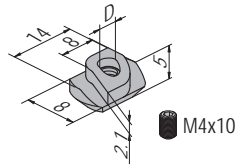

Description 产品描述	D	Mass 重量 (g/pcs)	Part No. 订购编号
Potential Equaliser Nut-8-M4 (with top thread) 导静电螺母-8-M4 (含凹端顶丝)	M4	3	8.22.08.M4
Potential Equaliser Nut-10-M5 (with top thread) 导静电螺母-10-M5 (含凹端顶丝)	M5	7	8.22.10.M5

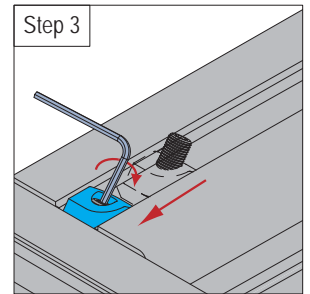
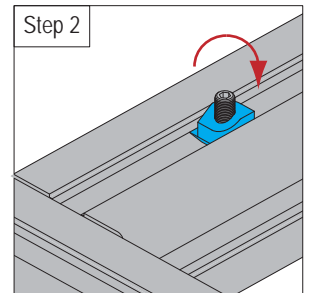
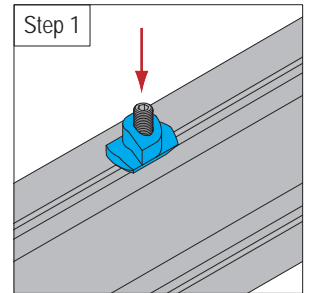
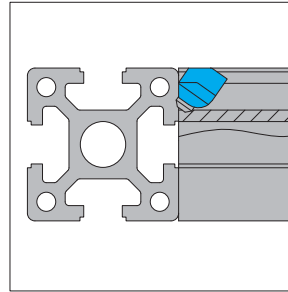

Additional Accessories
其他附件



Joint
枢轴
To connect movable profiles.
枢轴用来连接可活动的型材。
Material: zinc plated steel
材质: 碳钢镀锌



Joint-Type A
枢轴-A型

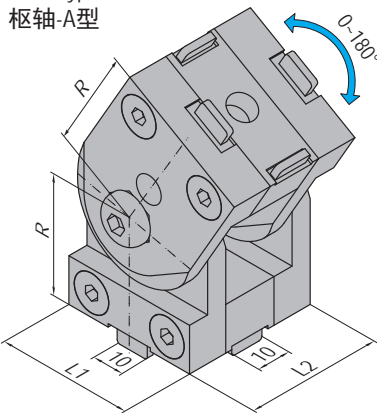

Joint-Type B
枢轴-B型

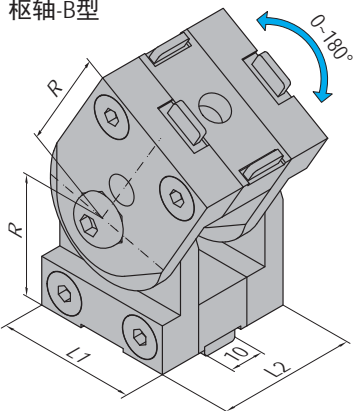

Joint-Type C
枢轴-C型

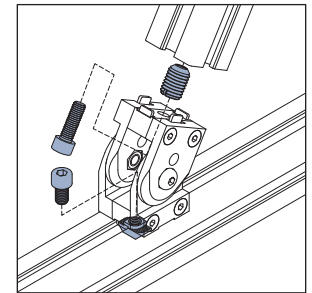
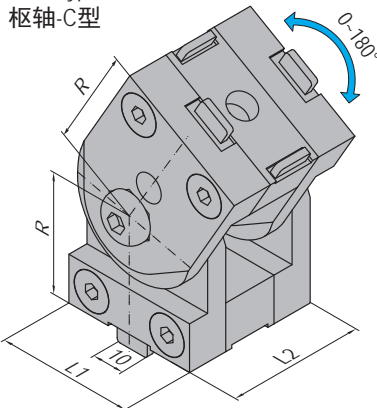

FD	Fastening Set	FX	Fastening Set
	M8x16 Bolt zinc plated		M8x20 Bolt zinc plated
	M8 T Nut nickel plated		M14-M8 Hole Reducer Bolt nickel plated

Description 描述	L1 (mm)	L2 (mm)	R (mm)	Fastening Set 紧固组件	Mass 重量 (g)	Part No. 订购编号
Joint-Type A-4040 枢轴-A型-4040	40	40	35	2xFX	560	8.31.4040A
Joint-Type A-4060 枢轴-A型-4060		60			680	8.31.4060A
Joint-Type A-4545 枢轴-A型-4545	45	45	37.5	2xFX	650	8.31.4545A
Joint-Type A-4560 枢轴-A型-4560		60			800	8.31.4560A
Joint-Type B-4040 枢轴-B型-4040	40	40	35	1xFD+1xFX	575	8.31.4040B
Joint-Type B-4060 枢轴-B型-4060		60			695	8.31.4060B
Joint-Type B-4545 枢轴-B型-4545	45	45	37.5	1xFD+1xFX	665	8.31.4545B
Joint-Type B-4560 枢轴-B型-4560		60			815	8.31.4560B
Joint-Type C-4040 枢轴-C型-4040	40	40	35	1xFD+1xFX	575	8.31.4040C
Joint-Type C-4060 枢轴-C型-4060		60			695	8.31.4060C
Joint-Type C-4545 枢轴-C型-4545	45	45	37.5	1xFD+1xFX	665	8.31.4545C
Joint-Type C-4560 枢轴-C型-4560		60			815	8.31.4560C



Additional Accessories
其他附件



Joint
枢轴
To connect movable profiles.
枢轴用来连接可活动的型材。
Material: zinc alloy
材质: 锌合金



Joint-Type A
枢轴-A型

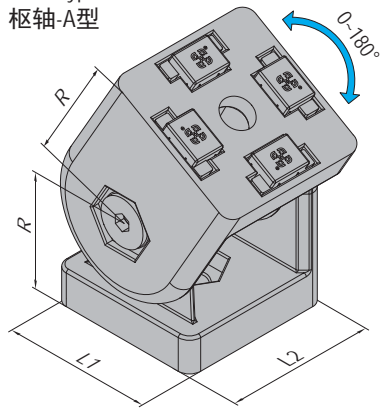

Joint-Type B
枢轴-B型

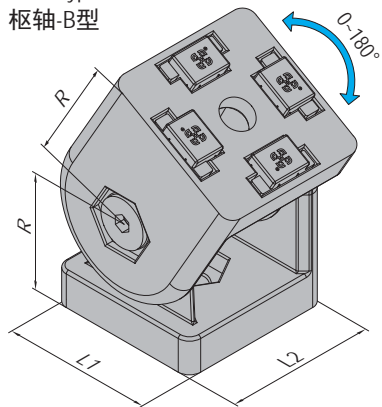

Joint-Type C
枢轴-C型

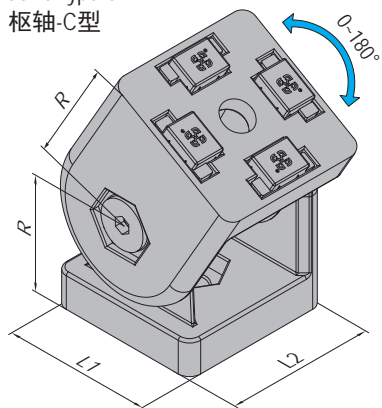

Note: Ratchet handle (part number RH) is an optional accessory for all three connection types-type A, B and C.

备注: 此枢轴三种连接方式A、B和C都可配棘轮把手, 编号RH。

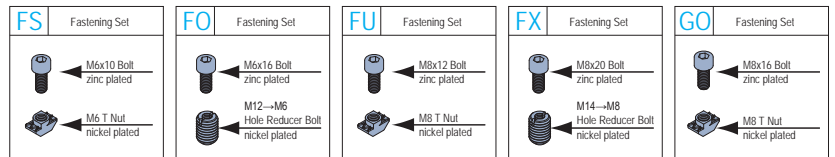

Description 描述	L1 (mm)	L2 (mm)	R (mm)	Fastening Set 紧固组件	Mass 重量 (g)	Part No. 订购编号
Joint-Type A-3030 枢轴-A型-3030	30	30	22.5	2xFO	181	8.32.3030A
Joint-Type A-3030-RH 枢轴-A型-3030-RH					211	8.32.3030A.RH
Joint-Type A-4040 枢轴-A型-4040	40	40	30	2xFX	388	8.32.4040A
Joint-Type A-4040-RH 枢轴-A型-4040-RH					447	8.32.4040A.RH
Joint-Type A-4060 枢轴-A型-4060	40	60	30	2xFX	498	8.32.4060A New!
Joint-Type A-4060-RH 枢轴-A型-4060-RH					549	8.32.4060A.RH New!
Joint-Type A-4545 枢轴-A型-4545	45	45	33.5	2xFX	530	8.32.4545A
Joint-Type A-4545-RH 枢轴-A型-4545-RH					587	8.32.4545A.RH
Joint-Type A-4560 枢轴-A型-4560	45	60	33.5	2xFX	614	8.32.4560A New!
Joint-Type A-4560-RH 枢轴-A型-4560-RH					665	8.32.4560A.RH New!
Joint-Type B-3030 枢轴-B型-3030	30	30	22.5	1xFS+1xFO	167	8.32.3030B
Joint-Type B-3030-RH 枢轴-B型-3030-RH					206	8.32.3030B.RH



Additional Accessories
其他附件



Joint
枢轴
To connect movable profiles.
枢轴用来连接可活动的型材。
Material: zinc alloy
材质: 锌合金



Joint-Type A
枢轴-A型

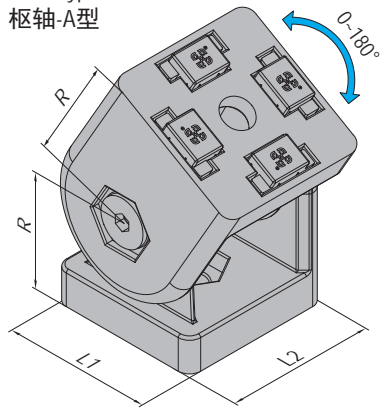

Joint-Type B
枢轴-B型

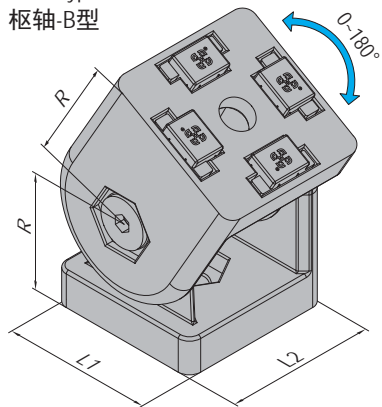

Joint-Type C
枢轴-C型

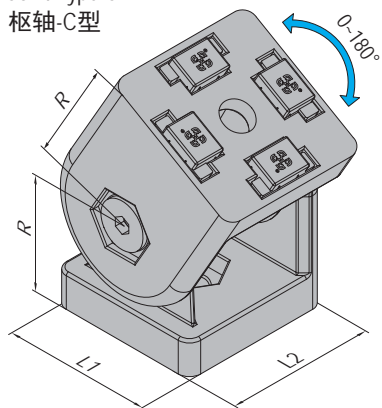

Note: Ratchet handle (part number RH) is an optional accessory for all three connection types-type A, B and C.

备注: 此枢轴三种连接方式A、B和C都可配棘轮把手, 编号RH。

FS	FO	FU	FX	GO
Fastening Set	Fastening Set	Fastening Set	Fastening Set	Fastening Set
M6x10 Bolt zinc plated	M6x16 Bolt zinc plated	M8x12 Bolt zinc plated	M8x20 Bolt zinc plated	M8x16 Bolt zinc plated
M6 T Nut nickel plated	M12→M6 Hole Reducer Bolt nickel plated	M8 T Nut nickel plated	M14→M8 Hole Reducer Bolt nickel plated	M8 T Nut nickel plated

Description 描述	L1 (mm)	L2 (mm)	R (mm)	Fastening Set 紧固组件	Mass 重量 (g)	Part No. 订购编号
Joint-Type B-4040 枢轴-B型-4040	40	40	30	1xFU+1xFX	366	8.32.4040B
Joint-Type B-4040-RH 枢轴-B型-4040-RH					437	8.32.4040B.RH
Joint-Type B-4060 枢轴-B型-4060	40	60	30	1xFU+1xFX	476	8.32.4060B New!
Joint-Type B-4060-RH 枢轴-B型-4060-RH					527	8.32.4060B.RH New!
Joint-Type B-4545 枢轴-B型-4545	45	45	33.5	1xFX+1xGO	510	8.32.4545B
Joint-Type B-4545-RH 枢轴-B型-4545-RH					577	8.32.4545B.RH
Joint-Type B-4560 枢轴-B型-4560	45	60	33.5	1xFX+1xGO	592	8.32.4560B New!
Joint-Type B-4560-RH 枢轴-B型-4560-RH					643	8.32.4560B.RH New!
Joint-Type C-3030 枢轴-C型-3030	30	30	22.5	1xFS+1xFO	167	8.32.3030C
Joint-Type C-3030-RH 枢轴-C型-3030-RH					206	8.32.3030C.RH
Joint-Type C-4040 枢轴-C型-4040	40	40	30	1xFU+1xFX	366	8.32.4040C
Joint-Type C-4040-RH 枢轴-C型-4040-RH					437	8.32.4040C.RH



Additional Accessories
其他附件



To connect movable profiles.
枢轴用来连接可活动的型材。
Material: zinc alloy
材质: 锌合金



Joint-Type A
枢轴-A型

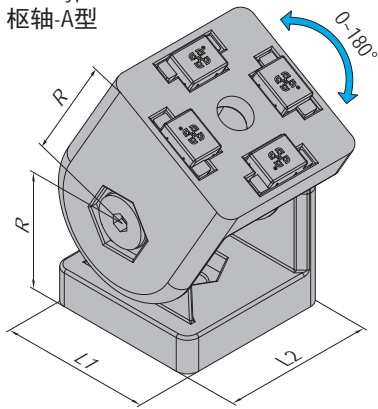

Joint-Type B
枢轴-B型

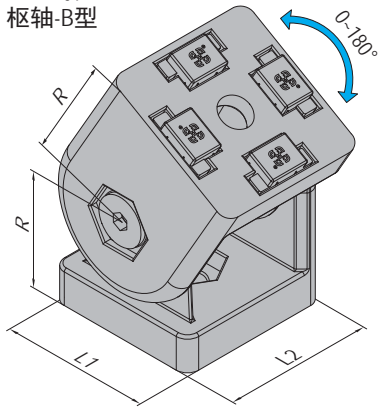



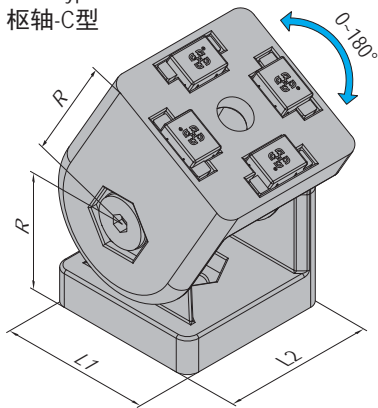







Joint-Type C
枢轴-C型



Note: Ratchet handle (part number RH) is an optional accessory for all three connection types-type A, B and C.

备注: 此枢轴三种连接方式A、B和C都可配棘轮把手, 编号RH。

FS	FO	FU	FX	GO
Fastening Set	Fastening Set	Fastening Set	Fastening Set	Fastening Set
 M6x10 Bolt zinc plated	 M6x16 Bolt zinc plated	 M8x12 Bolt zinc plated	 M8x20 Bolt zinc plated	 M8x16 Bolt zinc plated
 M6 T Nut nickel plated	 M12-M6 Hole Reducer Bolt nickel plated	 M8 T Nut nickel plated	 M14-M8 Hole Reducer Bolt nickel plated	 M8 T Nut nickel plated

Description 描述	L1 (mm)	L2 (mm)	R (mm)	Fastening Set 紧固组件	Mass 重量 (g)	Part No. 订购编号
Joint-Type C-4060 枢轴-C型-4060	40	60	30	1xFU+1xFX	476	8.32.4060C New!
Joint-Type C-4060-RH 枢轴-C型-4060-RH					527	8.32.4060C.RH New!
Joint-Type C-4545 枢轴-C型-4545	45	45	33.5	1xFX+1xGO	510	8.32.4545C
Joint-Type C-4545-RH 枢轴-C型-4545-RH					577	8.32.4545C.RH
Joint-Type C-4560 枢轴-C型-4560	45	60	33.5	1xFX+1xGO	592	8.32.4560C New!
Joint-Type C-4560-RH 枢轴-C型-4560-RH					643	8.32.4560C.RH New!



Additional Accessories
其他附件

Frame Joint
加强筋



When the profile frame is with big span and there is slight bending caused by self load, the frame joint shall be used with special connectors for cross connection to enhance the stability of the frame.

型材框架跨度较大时，因自重载荷产生少许形变，使用专用连接件进行交叉连接，增加框架可靠性。

Material: aluminium, anodized (cutting end not anodized).

材质：铝合金 表面处理：阳极氧化(切面无处理)。

End cap: black ABS

颜色：扣盖-黑色

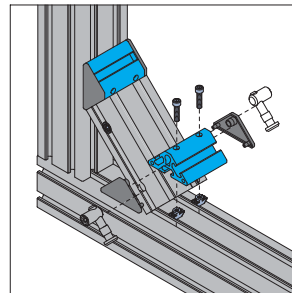
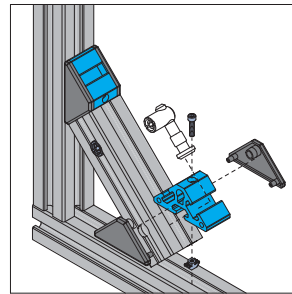
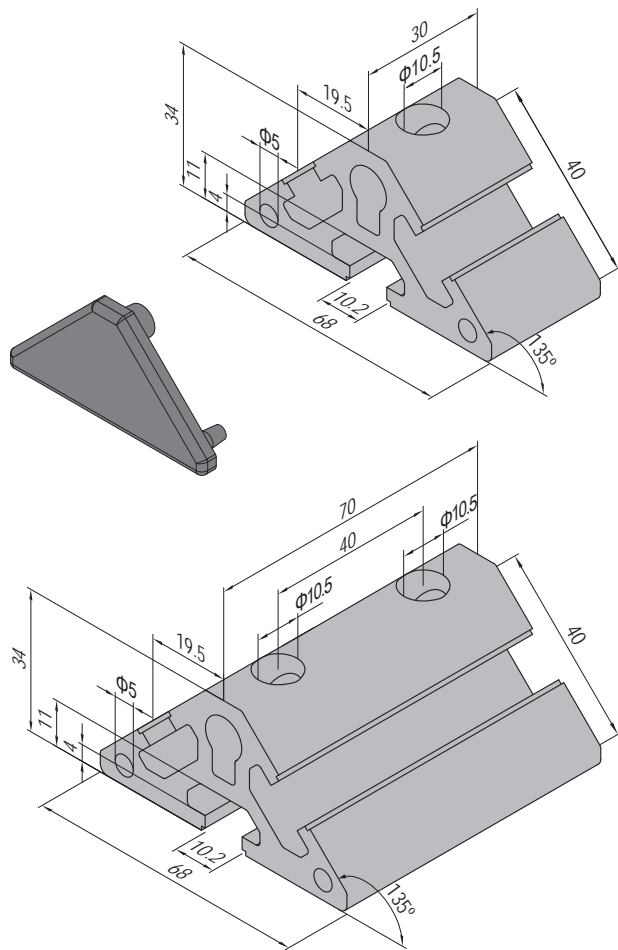

Description 产品描述	Fastening Set 紧固组件	End Cap 端盖	Mass 重量 (g)	Part No. 订购编号
PG40-4040 40系列-4040	1xCB	2	95	8.41.4040
PG40-4080 40系列-4080	2xCB		192	8.41.4080

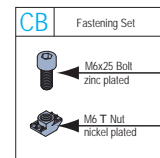

Note: Anchor Connector to be ordered separately refer to P. 3-03 for more detail.

备注：锚式连接销需单独订购，详情请参照P. 3-03。



Additional Accessories
其他附件

Mounting Adaptor for Roller
辊筒固定块

Special connector for quick roller installation.
辊筒专用连接件，安装快速方便。

Material: Adaptor-zinc alloy, polishing End cap: black PA6

材质：固定块-锌合金 端盖-尼龙6 表面处理：固定块-光饰 颜色：端盖-黑色



Mounting Adaptor for Roller-B
辊筒固定块-B

End Cap
端盖

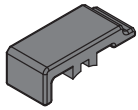

End Cap
端盖

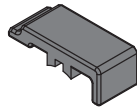

Left
左

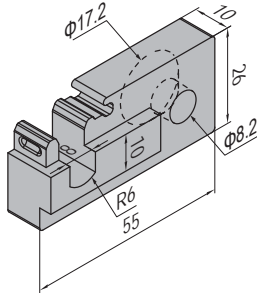

Right
右

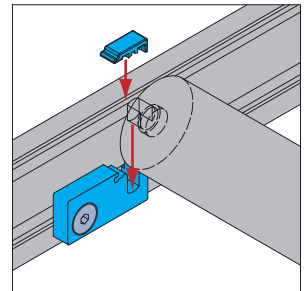
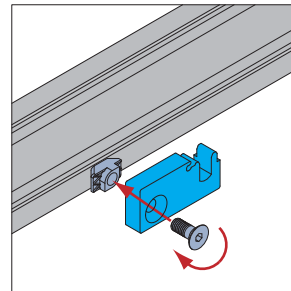
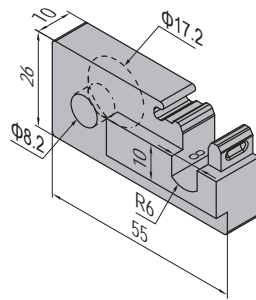

Description 描述	Fastening Set 紧固组件	End Cap 端盖	Mass 重量 (g)	Part No. 订购编号
Mounting Adaptor for Roller-B-Left+Right (pcs) 辊筒固定块-B-左+右(单个供货)		2	182	8.51.01B
Mounting Adaptor for Roller-B-Left+Right (set) 辊筒固定块-B-左+右(成套供货)	2xFQ		214	8.51.01B.ST

FQ	Fastening Set
	M8x20 Bolt zinc plated
	M8 T Nut nickel plated

Additional Accessories
其他附件

Telescope Unit
伸缩装置

Telescope Unit are composed of strut profile, telescopic profile and connecting elements, the stroke of telescope unit is 50-500mm.

伸缩装置是由基础框架型材、伸缩杆型材和连接组件构成, 伸缩行程范围50-500mm。

Telescope Unit-3030
伸缩装置-3030

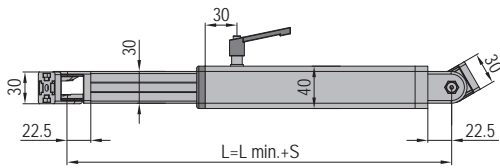

Telescope Unit-3040
伸缩装置-3040

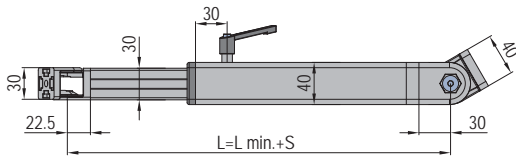

Description 描述	Fastening Set 紧固组件	Stroke 行程 S(mm)	L min. (mm)	Mass 重量 (kg)	Part No. 订购编号
Telescope Unit-3030 (set) 伸缩装置-3030 (成套供货)	2xFS	50≤S≤200	369	1.23	8.61.40.3030.01.ST
	2xFS	200<S≤350	519	1.43	8.61.40.3030.02.ST
	2xFS	350<S≤500	669	1.94	8.61.40.3030.03.ST
Telescope Unit-3040 (set) 伸缩装置-3040 (成套供货)	1xFS+1xFU	50≤S≤200	377	1.42	8.61.40.3040.01.ST
	1xFS+1xFU	200<S≤350	527	1.62	8.61.40.3040.02.ST
	1xFS+1xFU	350<S≤500	677	2.13	8.61.40.3040.03.ST

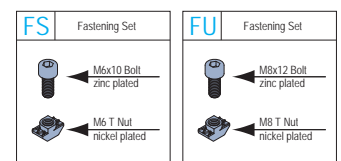

Note: Offer per set. If there is any special requirement on the stroke, please contact with us.
备注: 伸缩装置成套供货。如对行程有特殊要求请与我司联系。



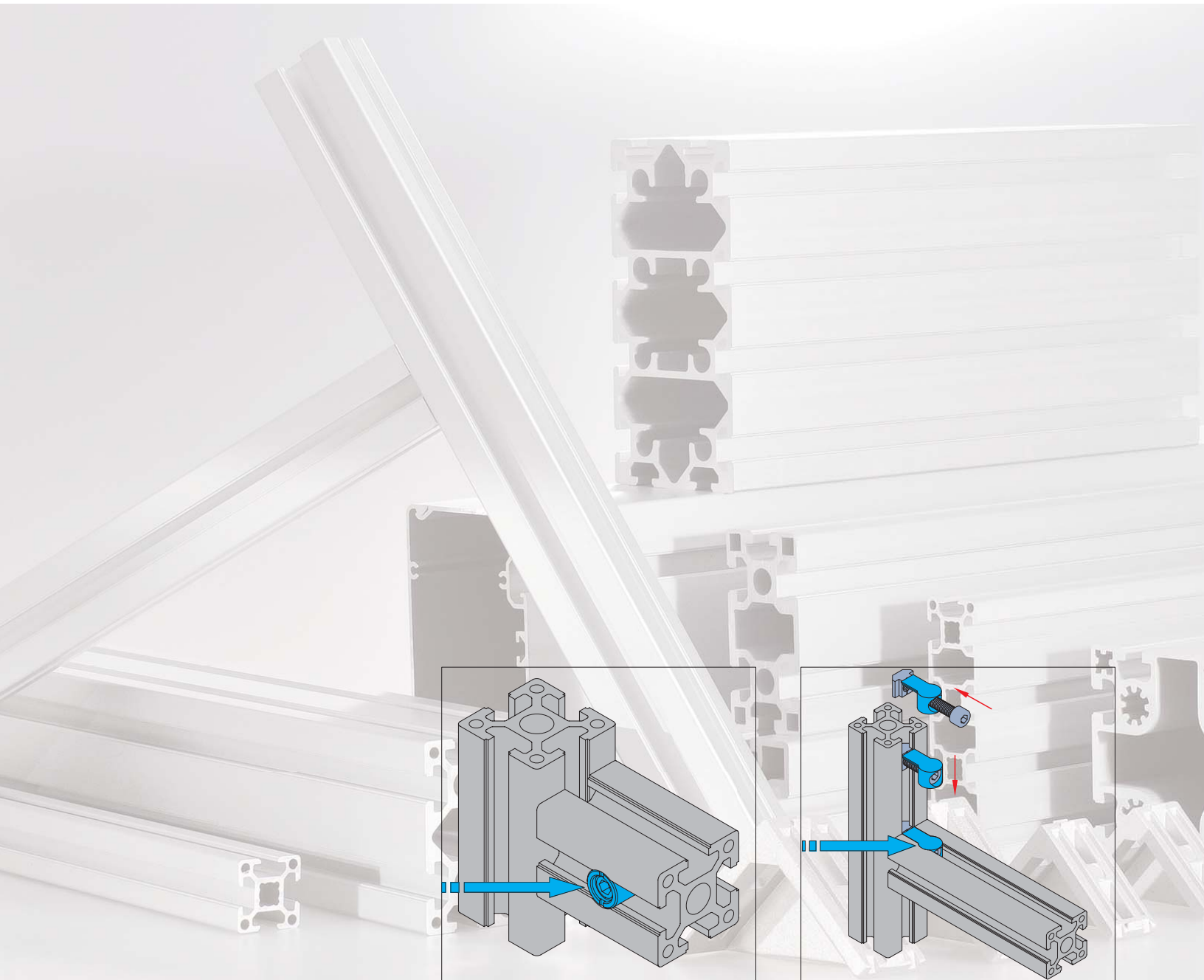







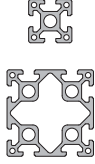
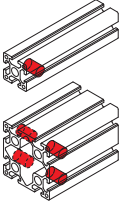
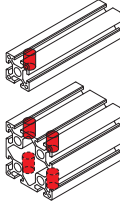
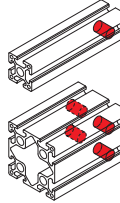
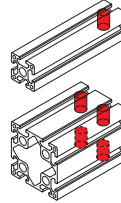

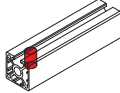
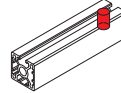

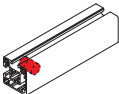
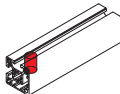
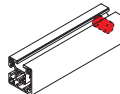
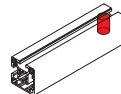

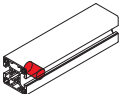
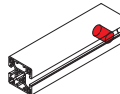

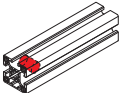
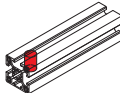
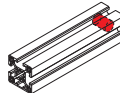
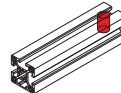
Profile Machining Code 型材加工编码

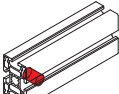
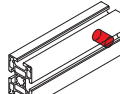
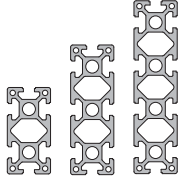
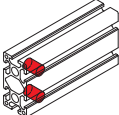
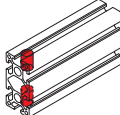
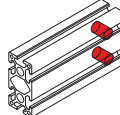
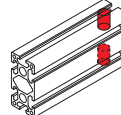

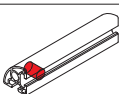
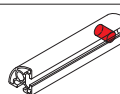
Dowel bore 销孔

Classification 分类		Dowel bore 销孔			
		Left 左		Right 右	
Code 编码		Horizontal 水平	Vertical 垂直	Horizontal 水平	Vertical 垂直
		LDH	LDV	RDH	RDV
Square 正方形					
		—		—	
					
			—		—
					
Rectangle 长方形			—		—
					
Arc 弧形		—	—	—	—
			—		—
		—	—	—	—

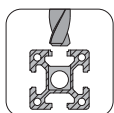



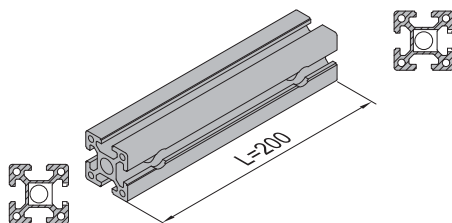



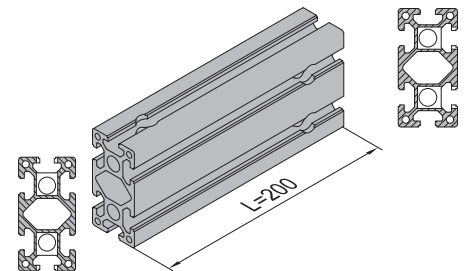



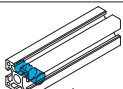
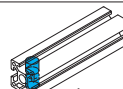
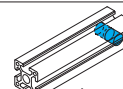
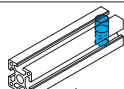

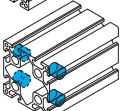
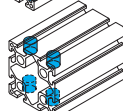
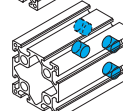
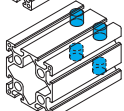

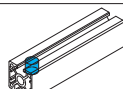
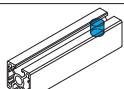
Example A: 1. 11. 40.040040.04H-200-LDH/RDH

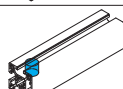
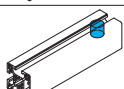

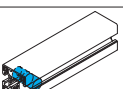
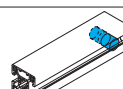
Example B: 1. 11. 40.040080.06H-200-LDV/RDH

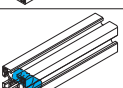
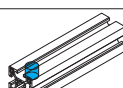
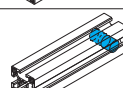
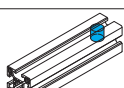
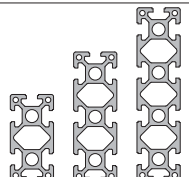
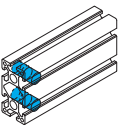
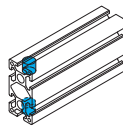
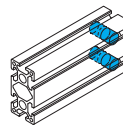
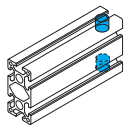

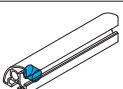
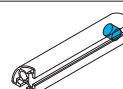
Inner connector bore 内置连接件孔

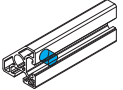
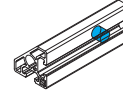
		Inner connector bore 内置连接件孔			
Classification 分类		Left 左		Right 右	
		Horizontal 水平	Vertical 垂直	Horizontal 水平	Vertical 垂直
Code 编码		LIH	LIV	RIH	RIV
Square 正方形					
					
		—		—	
		—		—	
			—		—
Rectangle 长方形					
					
Arc 弧形		—	—	—	—
			—		—
			—		—

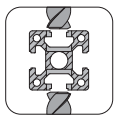



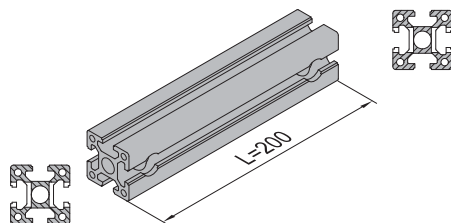



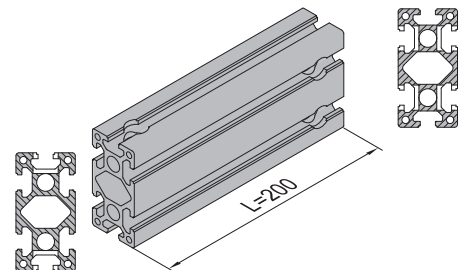



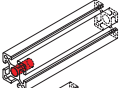
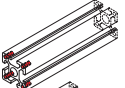
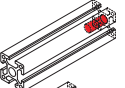
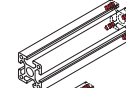
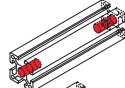
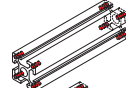

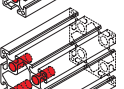
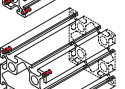
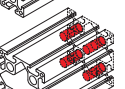
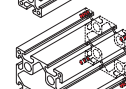

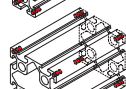

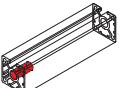
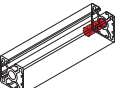
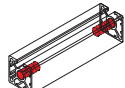

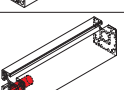
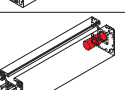
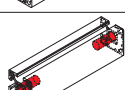
Example A: 1. 11. 40.040040.04H-200-LIH/RIH

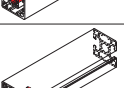
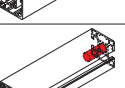
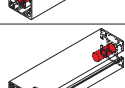

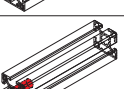
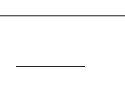
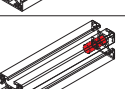
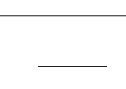
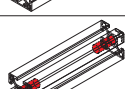
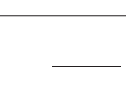
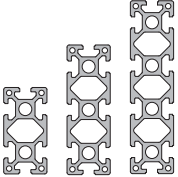
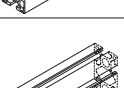
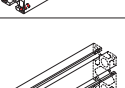
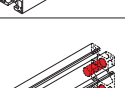
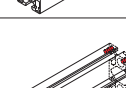
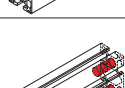
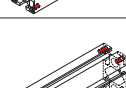
Example B: 1. 11. 40.040080.06H-200-LIV/RIH

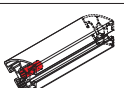
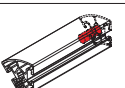
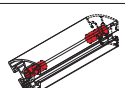

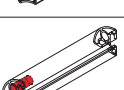
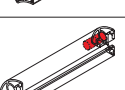
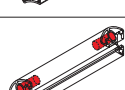
Screw thread bore 螺纹孔

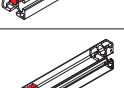
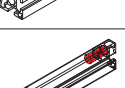
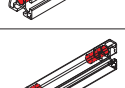
		Screw thread bore 螺纹孔					
Classification 分类		Left 左		Right 右		Left + Right 左 + 右	
Code 编码		LSP	LMP	RSP	RMP	WSP	WMP
Square 正方形							
							
			—		—		—
			—		—		—
			—		—		—
Rectangle 长方形							
							
Arc 弧形			—		—		—
			—		—		—
			—		—		—

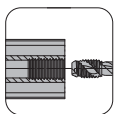

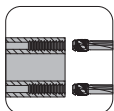
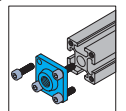
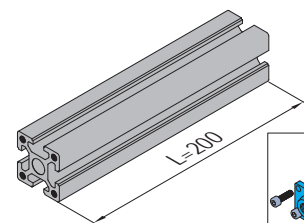
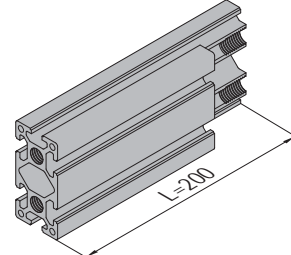
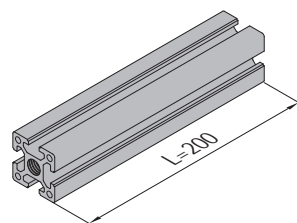

 Standard: depth=22mm
 标准螺纹有效深度=22mm

 Example A:
 1. 11. 40.040040.04H-200-LSP

 Example B:
 1. 11. 40.040080.06H-200-WSP

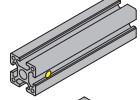
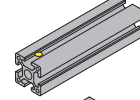
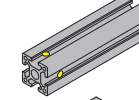
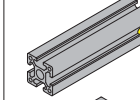
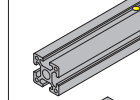
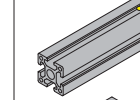
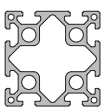
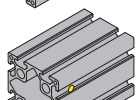
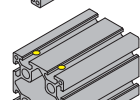
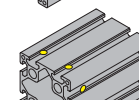
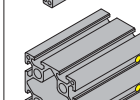
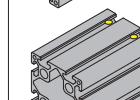
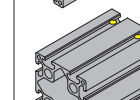
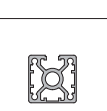
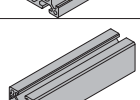
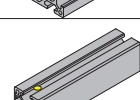
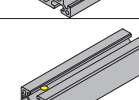
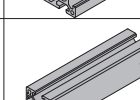
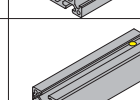
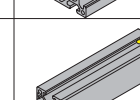
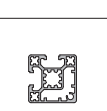
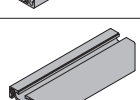
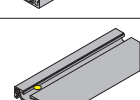
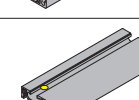
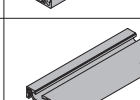
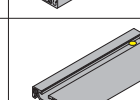
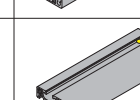
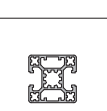
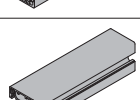
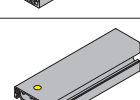
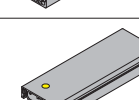
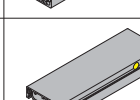
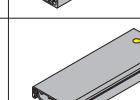
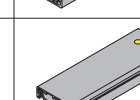
 Example C:
 1. 11. 40.040040.04H-200-LMP

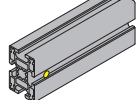
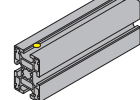
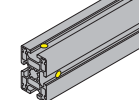
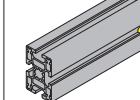
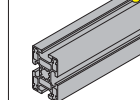
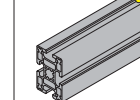
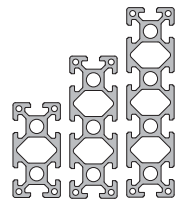
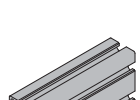
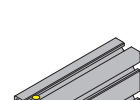
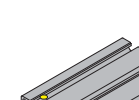
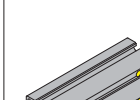
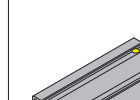
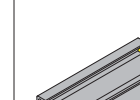
 Standard: depth=22mm
 标准螺纹有效深度=22mm

Cross bore 工艺孔

Classification 分类		Cross bore 工艺孔					
		Left 左			Right 右		
Code 编码		Horizontal 水平	Vertical 垂直	H+V 水平+垂直	Horizontal 水平	Vertical 垂直	H+V 水平+垂直
		LCH	LCV	LCP	RCH	RCV	RCP
Square 正方形							
							
							
							
							
Rectangle 长方形							
							



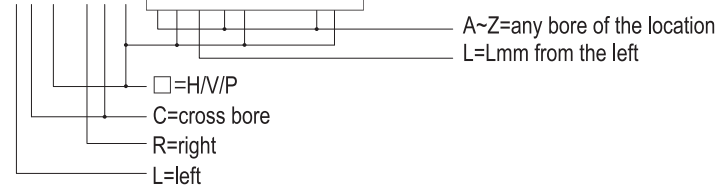





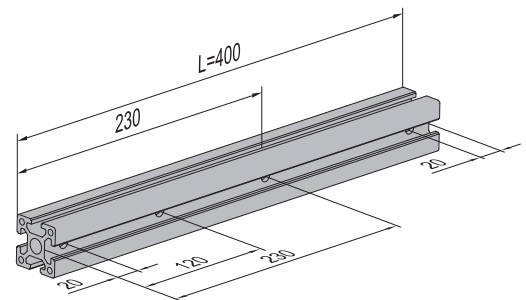

Specified crossing bore code

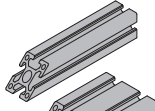
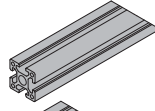
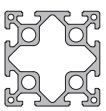
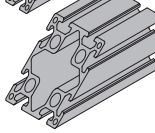
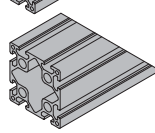
LC□/RC□-A□L-B□L-...Z□L

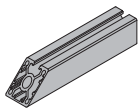
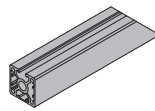
Example: 1. 11. 40.040040.04H-400-LCH/RCH-AH120-BP230

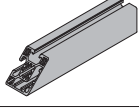
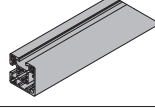

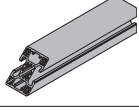
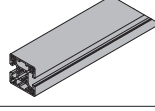
Angle cut 角度切割

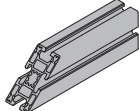
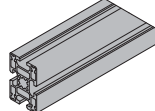
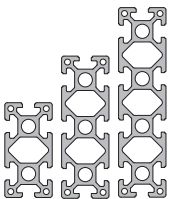
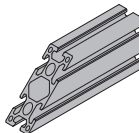
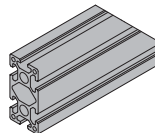
Classification 分类		Angle cut 角度切割	
		Left 左	Right 右
Code 编码		LCT(LAT,LBT,LDT)	RCT(RAT,RBT,RDT)
Square 正方形			
			
			
			
			
Rectangle 长方形			
			

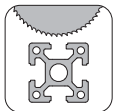

Specified cutting angle code
角度切割编码详细说明

L□Tα:



R□Tα:

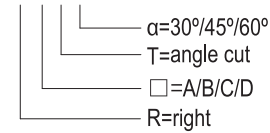

Example: 1. 11. 40.040080.06H-300-LDT45/RDT45

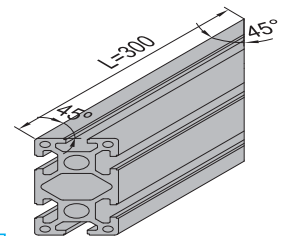

□=A向

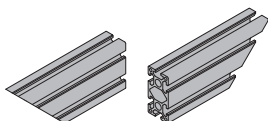

□=B向

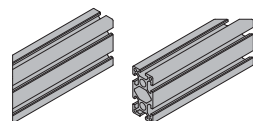

□=C向

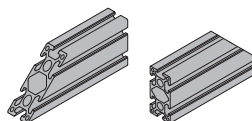

□=D向

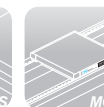
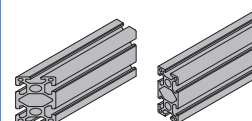

Our Worldwide Network 遍布全球的业务



Distributors

Africa | South Africa 

Europe | UK 

South America | Uruguay 

North America | Mexico 

Modular Website 美德乐网站

On our website you will find lots of information about our company and our products, you will also find your contact partner in your area and the latest catalogue (in PDF format) as download.

您可以通过我公司网站详细了解我公司及相关产品信息，同时也可在网站上直接下载我公司最新版PDF产品目录供您参考选型。

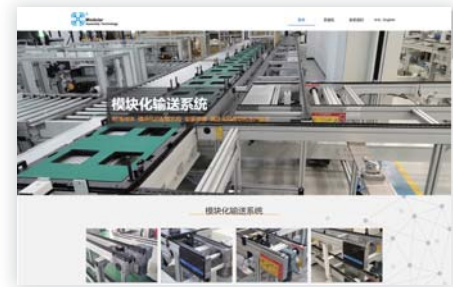

Modular Catalogue 美德乐产品目录

You could check more information on our catalogue, and also could select the most suitable products for your applications.

通过我公司的产品目录，您不仅可以进一步的了解更多更全的产品信息，而且还可以根据您的具体要求选择更适合您的产品。



Modular CD 美德乐光盘

A series of component data in 2D / 3D formats could be selected to support your design work.

为方便您的设计和选型，我公司还提供一系列的 2D / 3D 图库供您参考选型。



公司联系方式/Contact US

■ 公司总部/Headquarters

地址: 辽宁省大连市普兰店经济开发区海湾工业区
Add: Haiwan Industrial Park, Economic Development Zone
of Pulandian, Dalian, Liaoning Province, China
邮编/P.C.: 116200
电话/Tel: +86 (411) 66316200
传真/Fax: +86 (411) 66316208
电子邮箱/Email: sales@moduasm.com
网址/Website: www.moduasm.com

国际业务部/International Department
电话/Tel: +86 (411) 66316207
传真/Fax: +86 (411) 66316208
电子邮箱/Email: info@moduasm.com

■ 苏州子公司/Subsidiary Company

苏州美德乐工业自动化技术有限公司
Suzhou Modular Industrial Automation Technology Co., Ltd.
地址: 江苏省苏州市相城区经济技术开发区澄阳街道澄阳路958号
Add: No. 958 Chengyang Road, Chengyang Street, Xiangcheng Economic
Development Zone, Suzhou 21500, Jiangsu Province, China
电子邮箱/Email: sales.sz@moduasm.com

■ 深圳办事处/Shenzhen Office

电子邮箱/Email: sales.shenzhen@moduasm.com



Modular Assembly Technology Co., Ltd.
大连美德乐工业组装技术有限公司

! We reserve the right to update our product specifications and improve the production process without any notice and obligations, please refer to the our latest catalogues from our website or contact us at info@moduasm.com.
本公司保留对所有产品技术参数及生产工艺升级更新的权利, 若有变更, 恕不另行通知, 最新资讯请登录网站查询或来电咨询。



www.moduasm.com

Modular Assembly System