

# AIG Ion Gauge

UHV Nude Bayard-Alpert Ion Gauge

The AML AIG nude ionization gauge is a high-sensitivity UHV Bayard-Alpert gauge covering the vacuum range of  $3 \times 10^{-11}$  to  $1 \times 10^{-3}$  mbar and is intended for electron-bombardment degas. It has an NW35CF flange with in-dividual glass compression seals, closed-end grid and a choice of filament materials.

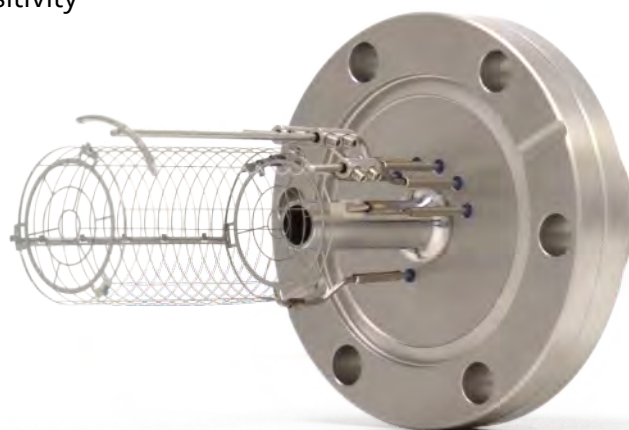

## FEATURES

- Wide measuring range  $3 \times 10^{-11}$  to  $1 \times 10^{-3}$  mbar
- Replaceable twin Tungsten, Thoria or Yttria-coated Iridium filaments
- Individual glass compression seal around each feedthrough pin are more economical and robust than ceramic, resulting in a less expensive and more rugged gaugehead, with the central collector pin inherently guarded against leakage currents by the grounded bulk of the flange
- The molybdenum grid has a closed-end, light, rigid structure, resulting in high sensitivity. The X-Ray induced electron desorption current at the collector is minimised by geometry and screening
- Connector pins are gold-plated, shrouded and polarized. Gold plating ensures that oxidation on the air-side cannot occur even after repeated bakeouts
- Maximum bakeout temperature 450 °C. Sensitivity 19 per mbar for nitrogen. X-Ray asymptote  $3 \times 10^{-11}$  mbar
- RoHS compliant



[www.motiontech.com.au](http://www.motiontech.com.au)

## SPECIFICATIONS

Measurement range	3x10 <sup>-11</sup> to 1x10 <sup>-3</sup> mbar / 2.2x10 <sup>-11</sup> to 1x10 <sup>-3</sup> Torr
X-ray limit	3x10 <sup>-11</sup> mbar
Sensitivity for N <sub>2</sub>	19/mbar
Degas power	50 W (maximum)
Bakeout temperature	450 °C
Filament	Dual Tungsten or dual yttria coated iridium or dual thoria coated iridium
Mounting flange	NW35CF (2.75")
Mounting position	Any
Collector potential	0 V
Grid potential	+200 V
Filament bias	+50 V
Maximum emission	10 mA(W), 60 mA (Ir)

## DIMENSIONS

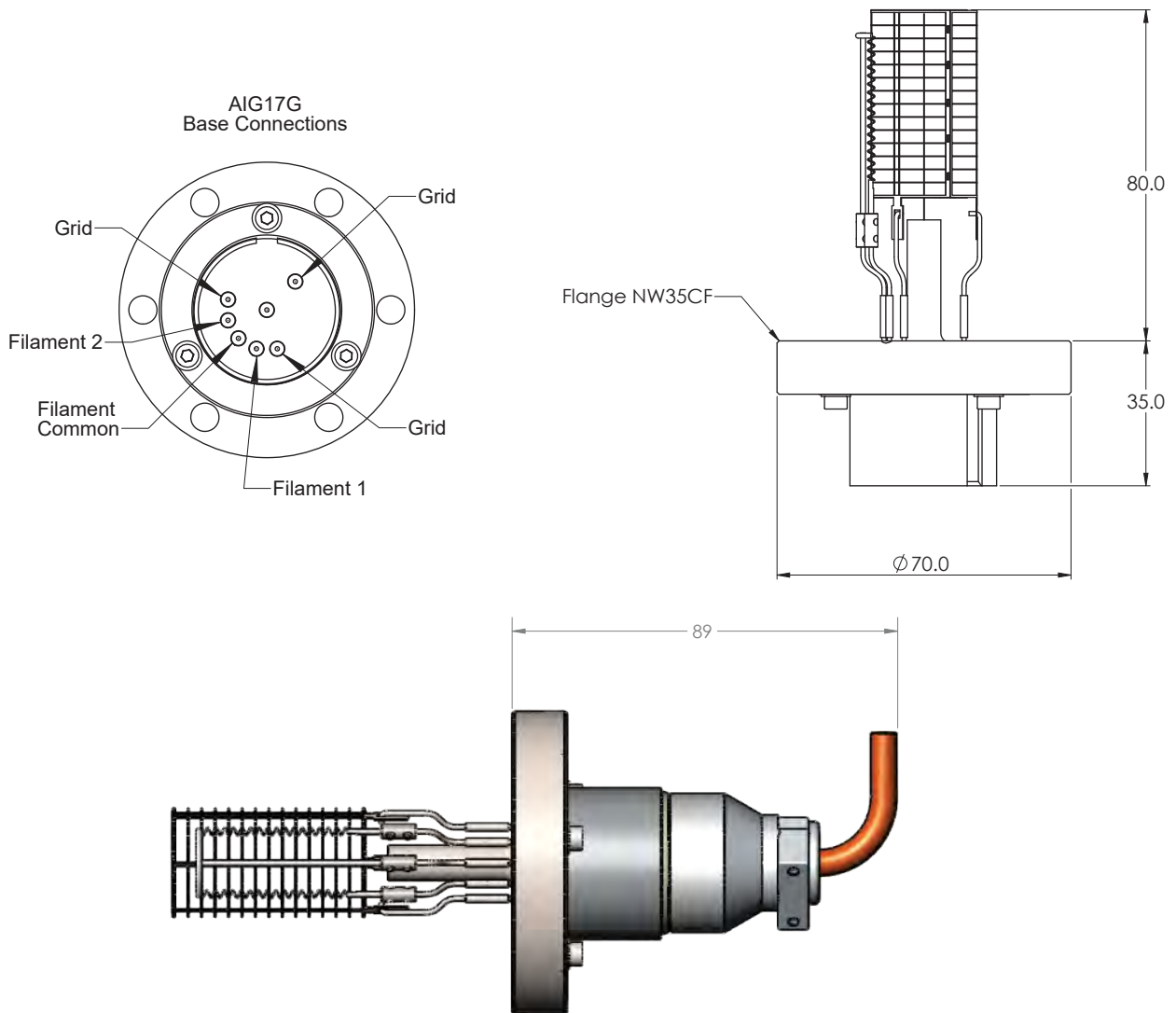

## FEATURES

### Filament Types

Filament power varies over the useful life of a filament, due to gradual erosion of bare tungsten or loss of the oxide coating. In general, Thoria-coated iridium filaments require about one quarter the power of tungsten at mid-life. Yttria has similar properties and runs less than 50 °C hotter in normal emission. Yttria also has better adhesion and consequently longer life. Oxide-coated filaments absorb water in storage and may require more power initially to evaporate it.

The filament power supply must be capable of providing high currents to develop adequate power in the low resistance of a cold filament and sufficient voltage to compensate for drops in a long, hot cable. A power-limited supply of 40 W capable of providing up to 12 V and up to 4 A will drive any AIG17G gauge operating under any conditions, (including degassing during bakeout at 250 °C) with an AIGL9 lead. AML BA gauge controllers exceed these requirements and include comprehensive filament protection features.

### Replacement Filaments

Replacement filament assemblies are available in tungsten, thoria and Yttria-coated iridium. The assembly is held by Allen set screws in socket receptacles and a key and replacement screws are provided.



### AIGL Gauge Lead

The AIGL is a 250 °C bakeable lead for use with AIG and similar ionisation gauges connected to AML controllers. They are available in 3, 6 and 9 metre versions or custom lengths to order. AML use gold-plated connectors exclusively: these are essential for reliable long-term measurement of the ion current after baking. The cable is rated for the worst-case operating conditions of 50 W degas with a new tungsten filament during a 200 °C bake. This product incorporates a fully screened and guarded collector with  $>1 \times 10^{15} \Omega$  insulation. The connector housing is machined from PEEK and the cable clamp is anodized aluminium.



## ORDERING INFORMATION

Order Code	
AIG17G	UHV BA Ion Gauge, 2 x Tungsten filaments
AIG18G	UHV BA Ion Gauge, 2 x Thoria coated filaments
AIG19G	UHV BA Ion Gauge, 2 x Yttria coated filaments

AIGL3	3 metre bakeable ion gauge cable
AIGL6	6 metre bakeable ion gauge cable
AIGL9	9 metre bakeable ion gauge cable

FIL17	Replacement filament assembly, Tungsten
FIL18	Replacement filament assembly, Thoria coated
FIL19	Replacement filament assembly, Yttria coated



**Distributors for Australia & New Zealand**  
**MOTION TECHNOLOGIES PTY LIMITED**

24/22-30 Northumberland Road  
 Caringbah NSW 2229 Australia  
 Phone: (02) 9524 4782

sales@motiontech.com.au  
 www.motiontech.com.au

© 23/06/2023



AML pursues a policy of continuous improvement and reserves the right to make detail changes to specifications without consultation. E and OE.