



MOONS'
moving in better ways

MDX SERIES

INTEGRATED SERVO MOTOR



DRIVE + MOTOR + CONTROL

www.motiontech.com.au

SHANGHAI AMP&MOONS' AUTOMATION CO.,LTD.

The MDX series, integrated servo motors are used to create decentralized motion control solutions in very compact units. They consist of a *servo motor*, *feedback sensor* and *drive/controller system*. They are controlled via a communication bus, or I/O interface (Q Program).

The integrated servo motor is designed with a synchronous servo motor, thus providing numbers possibilities for user in a wide variety of applications.

■ Features Overview

- Space-saving design
- 24-60VDC Power supply input
- IP20 and IP65 protection
- Freely Q Program available
- With CANbus (CiA 301 & CiA 402) or RS-485 interface
- High position accuracy and excellent control characteristics
- PC-software easy to use for parameterization. Basic mode such as position, velocity and torque are easy to parameterization.

■ Applications

Packging

Textile

Medical

Electronic components

Checking weighing

AGV



■ Waterproof and dustproof

MDX series integrated servo motors have IP65 rating high waterproof and dustproof characteristics.

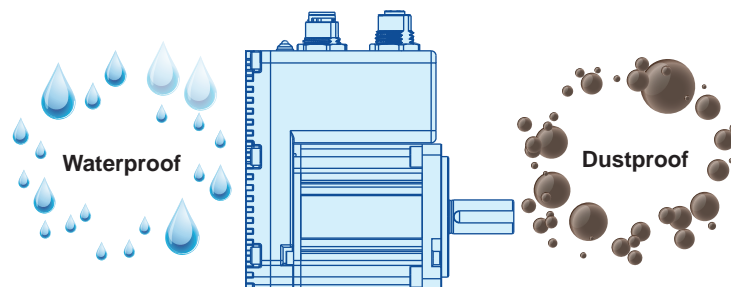

■ Space-saving design (Unit:mm)

In our pursuit of making compact and space-saving design, we have reduced the length of the motor by about 20% , thus allowing for mounting within the equipment with limited installation space.

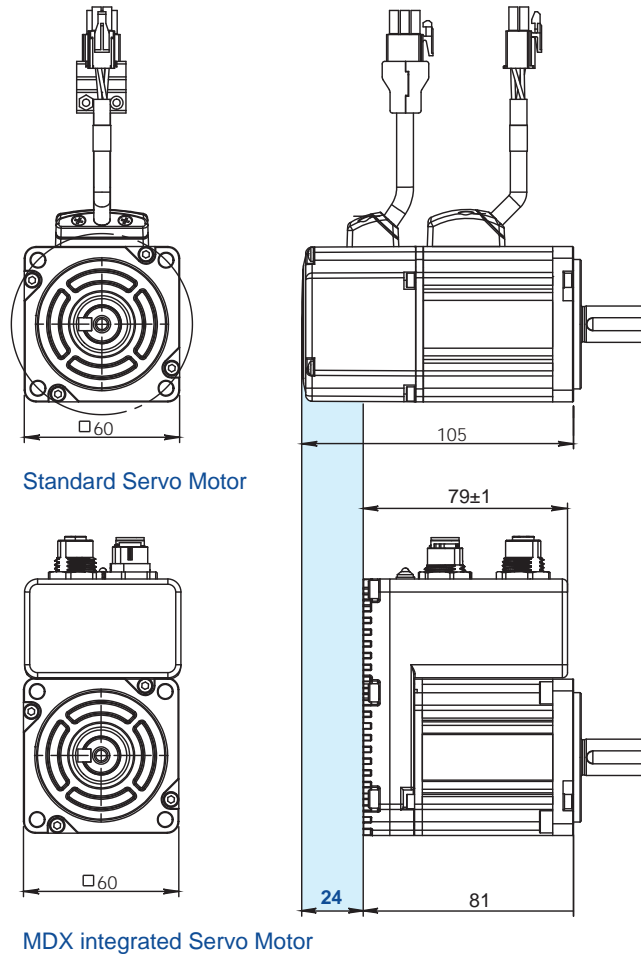

■ Easy setup and Servo tuning

PC-based configuration software

- Friendly interface
- Easy set-up
- Drive set-up and configuration
- Built in oscilloscope for motion testing and monitoring
- Write and save SCL scripts
- On-line help integrated

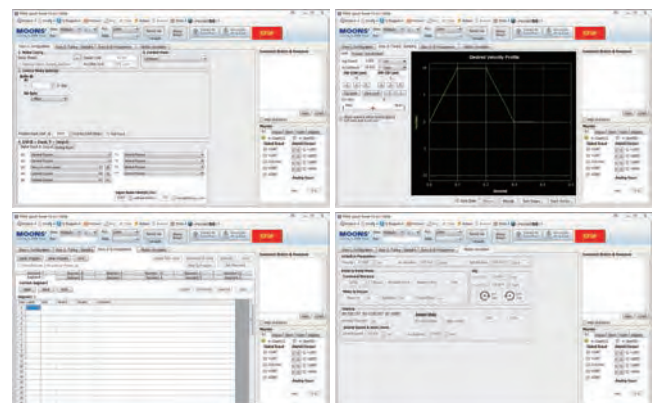

Freely Q Program

Q Programmer is MOONS' own single-axis motion control software based on SCL commands. It can create sophisticated and functional programs that can be saved to a drive's nonvolatile memory, and then runs stand-alone, or without a permanent connection to the host. Q drives offer a high level of flexibility and functionality to the machine designer and system integrator.

Features

- Motion control commands (relative position, absolute position, homing mode, etc.)
- Multi-tasking
- Conditional processing (external I/O, internal command)
- Math calculation (+, -, *, /, &, or)
- Data register manipulation
- Logic motion command (loop, call functions)

Line	Label	Cmd	Param1	Param2	Comment
1		MT	1		Turn ON Multi-Tasking
2		DL	3		Turn OFF limits
3		PF	2000		Set Position Fault limit
4		CC	2		Set continuous current to 50%
5		CP	2		Also set peak current to same
6		DI	-4000		Make distance positive for CW
7		JM	1		Set Jog mode to positioning
8		JS	1		Set Jog speed to 1 rev/sec
9		JA	10		Set Jog accel to 10 rev/sec/sec
10		CJ			Start jogging
11	Label2	TR	x	100	Test Reg "x" against 100
12		QJ	G	#Label1	Jump if greater than
13		TR	x	-100	Test Reg "x" against -100
14		QJ	G	#Label2	Jump if greater than
15	Label1	SM	M		Stop move with max accel (AM)
16		WM			Wait for stop to complete
17		EP	0		Set encoder position to zero
18		VE	1		Set Velocity to 1 rev/sec
19		DI	-8000		Set home offset distance (CCW)
20		FL			Do a Relative move
21		WM			Wait for move to complete
22		SP	0		Set absolute position to zero
23		AX			Clear any faults just in case
24		WT	0.1		Wait 0.1 seconds
25		ME			Enable servo drive

Fieldbus Control



Standard CAN bus interfaces are available in MDX series, which make it easily to get integrated to a industrial field bus.

Items	Specification
Communication Protocol	CiA 301 Application Layer and Communication Profile CiA 402 Device Profile Drives and Motion Control
Baud Rate	12.5Kbps, 20Kbps, 50Kbps, 125Kbps, 250Kbps, 500Kbps, 800Kbps, 1Mbps
Communication Objects	SDO, PDO, SYNC, EMCY, NMT, Heartbeat
Control Mode	Profile Position, Profile Velocity, Profile Torque, Homing Mode
PDO Data	4 RxPDOs, 4 TxPDOs
Support Axis	Up to 112 axis



MDX series integrated servo motor provides the Modbus/RTU communication function with provides/RS-485 interface which can be used to easily control the motor, set parameters or monitor the status of the drive.

Items	Specification
Physical Layer Standard	RS-485
Communication Protocol	Modbus/RTU
Baud Rate	9600bps, 19200bps, 38400bps, 57600bps, 115200bps
Control Mode	Position Mode, Velocity Mode, Torque Mode, Homing Mode
Support axis	Up to 32 axis

■ Numbering System

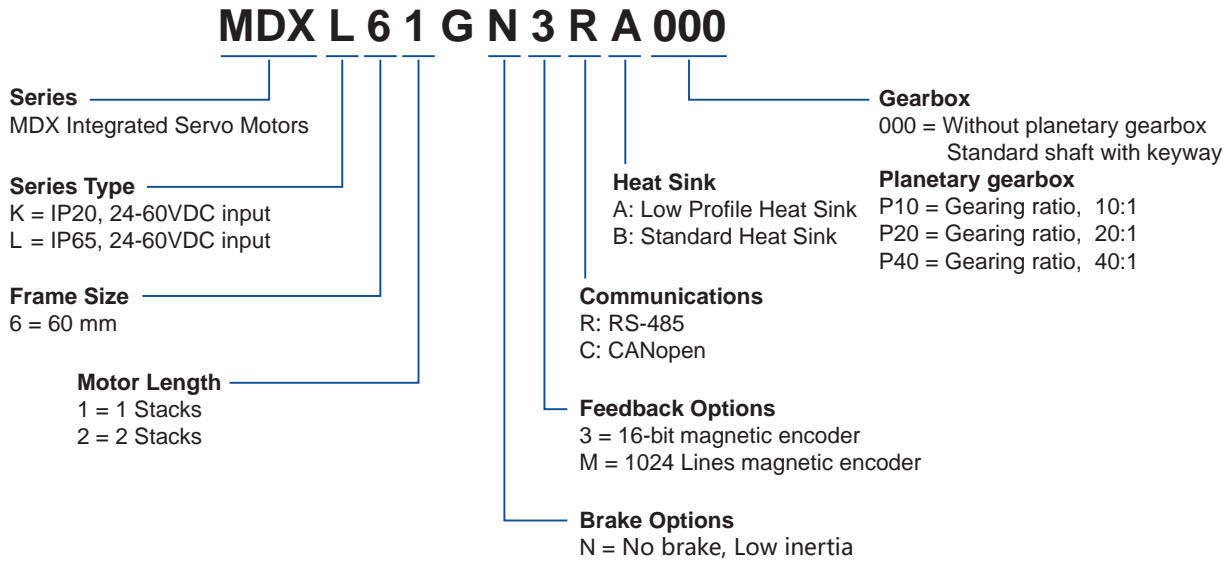

■ General Specifications

Type	MDXK61GN3□□□□□□ MDXK61GNM□□□□□□	MDXK62GN3□□□□□□ MDXK62GNM□□□□□□	MDXL61GN3□□□□□□ MDXL61GNM□□□□□□	MDXL62GN3□□□□□□ MDXL62GNM□□□□□□
IP Rating	IP20		IP65	
Power Rating	200W	400W	200W	400W
Input Voltage	24-60VDC			
Recommend Input voltage	48VDC			
Encoder	M = 1024 Lines magnetic encoder 3 = 16-bit magnetic encoder			
Communications	-R Type: RS-485 -C Type: R-232, CANbus			
Communication protocol	-R Type: SCL, Modbus/RTU -C Type: CANopen (CiA301, CiA402)			
Digital Inputs	8 Optically isolated inputs: X1/X2: differential input, 5-24VDC, up to 20mA, 2MHz, max. pulse width 250ns X3/X4/X5/X6: single-ended input, 5-24VDC, up to 20 mA, 10KHz. X7/X8: optically isolated differential input, 5-24VDC, up to 20 mA, 10KHz.		5 Optically isolated inputs: X1/X2: differential input, 5-24VDC, up to 20mA, 2MHz, max. pulse width 250ns X3/X4/X5: single-ended input, 5-24VDC, up to 20 mA, 10KHz.	
Analog Inputs	2 Analog inputs (0~+10VDC, 12-bit)			
Digital Outputs	4 Optically isolated outputs: Y1/Y2/Y3/Y4: open collector, 30VDC, 100mA max.			
Protection	Over-temp, over-voltage, under-voltage, over-current			
Insulation Class	Class B			
Temperature	Ambient temperature: 0°C to 40°C (If the ambient temperature of the drive is higher than 45°C, please install the drive in a well-ventilated location)			
Humidity	Both operation and storage: 10 to 85% non-condensing			

■ Descriptions — Low Profile Heat Sink — IP20 Type



- IP20 Rating
- Frame Size: 60mm
- Power Rating: 200W, 400W
- 8 Digital Inputs
- 4 Digital Outputs
- 2 Analog Inputs
- Support RS-485 or CANopen
- Without planetary gearbox
- Standard shaft with keyway

Part Number	Unit	MDXK61GN3□A000 MDXK61GNM□A000		MDXK62GN3□A000 MDXK62GNM□A000	
		24	48	24	48
Winding Type	VDC	48		48	
Nominal Supply Voltage	VDC	24	48	24	48
Rated Speed	rpm	2000	3000	1600	3000
Power Rating (at 3000rpm)	W	200		400	
Motor Continuous Torque	N.m	0.64		1.27	
Motor Peak Torque	N.m	1.7		3.0	
Rotor Inertia	Kg·m ²	0.165 x 10 ⁻⁴		0.272 x 10 ⁻⁴	
Shaft Load - Axial	N (max.)	70		70	
Shaft Load - Radial (End of Shaft)	N (max.)	200		240	
Weight	kg	1.18		1.55	

Dimensions (Unit: mm)

- MDXK61GN3 □ A000
- MDXK61GNM □ A000

- MDXK62GN3 □ A000
- MDXK62GNM □ A000

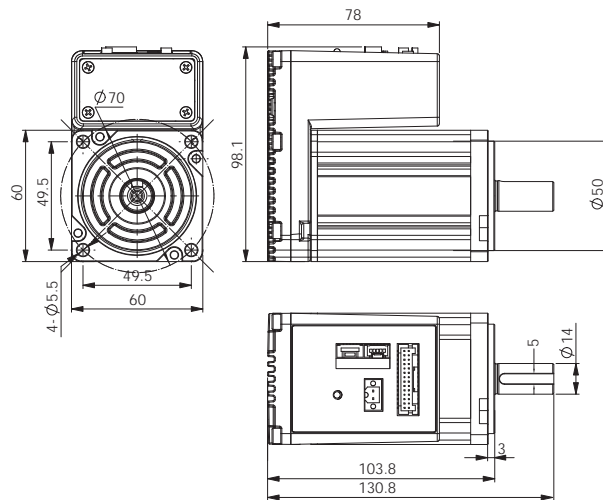
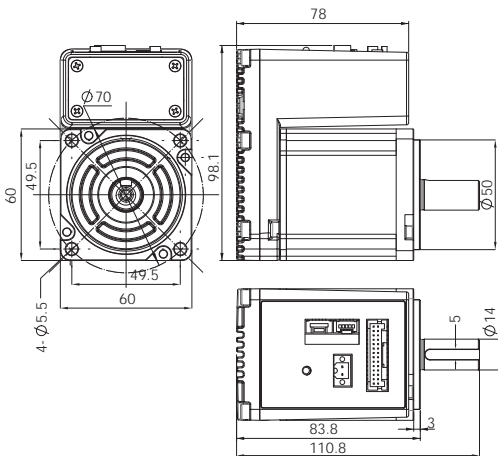

Torque Curves

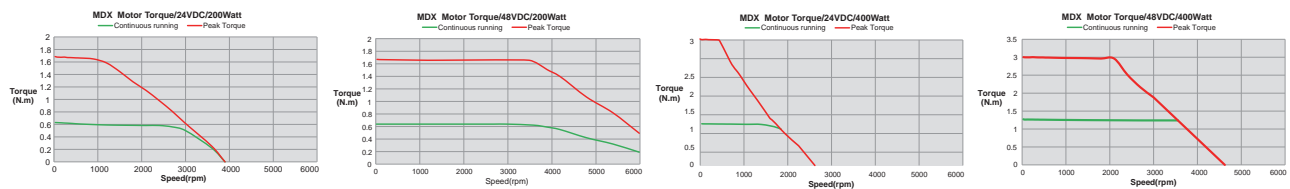

Descriptions—Low Profile Heat Sink — IP20 Type



- IP20 Rating
- Frame Size: 60mm
- Power Rating: 200W, 400W
- 8 Digital Inputs
- 4 Digital Outputs
- 2 Analog Inputs
- Support RS-485 or CANopen
- With planetary gearbox

Part Number	Unit	MDXK61GN3□AP□□ MDXK61GNM□AP□□		MDXK62GN3□AP□□ MDXK62GNM□AP□□	
		24	48	24	48
Winding Type	VDC	48VDC		48VDC	
Nominal Supply Voltage	VDC	24	48	24	48
Rated Speed	Rpm	2000	3000	2000	3000
Power Rating (at 3000rpm)	W	200		400	
Motor Continuous torque (Without Gearbox)	N.m	0.64		1.27	
Motor Peak Torque (Without Gearbox)	N.m	1.7		3.0	
Rotor Inertia	Kg-m ²	0.165 x 10 ⁻⁴		0.272 x 10 ⁻⁴	
Shaft Load - Axial	N (max.)	70		70	
Shaft Load - Radial (End of Shaft)	N (max.)	200		240	
Weight - Motor	kg	1.18		1.55	
Weight - Gearbox	kg	0.68(10:1), 0.97(20:1), 1.18(40:1)			
Gear Ratio	-	10:1, 20:1, 40:1			

Dimensions (Unit: mm)

- MDXK61GN3 □ AP □ □
- MDXK61GNM □ AP □ □

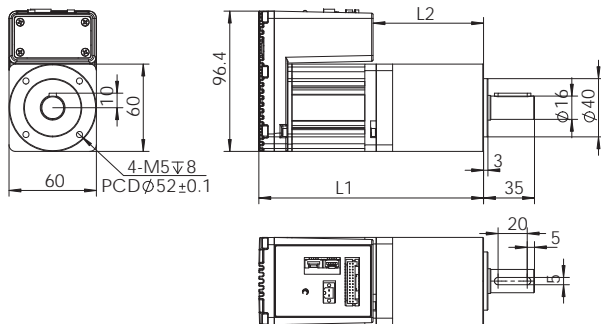

Model	L1	L2
MDXK61GN□□AP10	139.6 ± 1	61.4 ± 1
MDXK61GN□□AP20	154.1 ± 1	75.9 ± 1
MDXK61GN□□AP40	154.1 ± 1	75.9 ± 1

- MDXK62GN3 □ AP □ □
- MDXK62GNM □ AP □ □

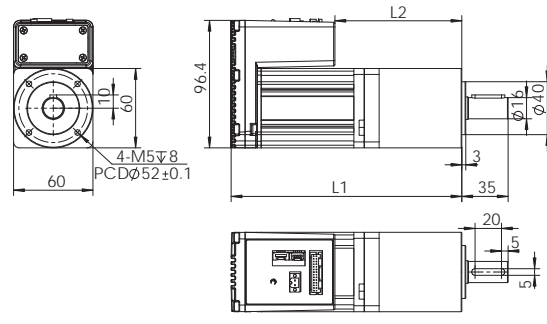

Model	L1	L2
MDXK62GN□□AP10	159.6 ± 1	81.4 ± 1
MDXK62GN□□AP20	174.1 ± 1	95.9 ± 1
MDXK62GN□□AP40	174.1 ± 1	95.9 ± 1

Torque Curves(Without gearbox)

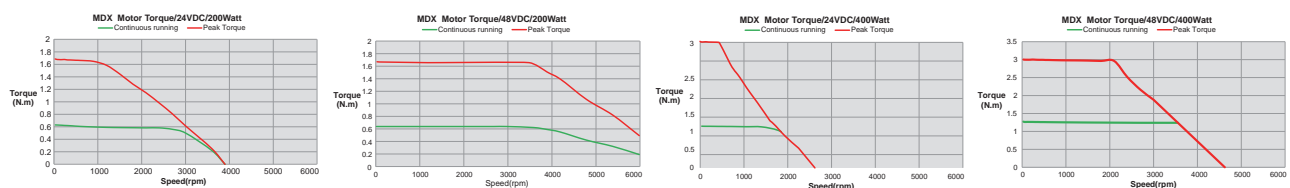

■ Descriptions—Low Profile Heat Sink — IP65 Type



- IP65 Rating
- Frame Size: 60mm
- Power Rating: 200W, 400W
- 5 Digital Inputs
- 4 Digital Outputs
- 2 Analog Inputs
- Support RS-485 or CANopen
- Without gearbox
- Standard Shaft with Keyway

Part Number	Unit	MDXL61GN3□A000 MDXL61GNM□A000		MDXL62GN3□A000 MDXL62GNM□A000	
		24	48	24	48
Winding Type	VDC	48VDC		48VDC	
Nominal Supply Voltage	VDC	24	48	24	48
Retard Speed	Rpm	2000	3000	1600	3000
Power Rating (at 3000rpm)	W	200		400	
Motor Continuous Torque	N.m	0.64		1.27	
Motor Peak Torque	N.m	1.7		3.0	
Rotor Inertia	Kg-m ²	0.165 x 10 ⁻⁴		0.272 x 10 ⁻⁴	
Shaft Load - Axial	N (max.)	70		70	
Shaft Load - Radial (End of Shaft)	N (max.)	200		240	
Weight	kg	1.25		1.63	

Dimensions (Unit: mm)

- MDXL61GN3 □ A000
- MDXL61GNM □ A000

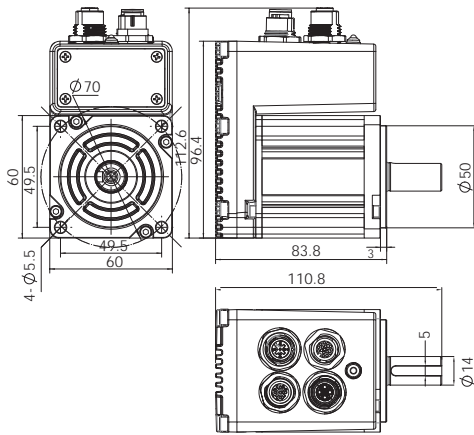

- MDXL62GN3 □ A000
- MDXL62GNM □ A000

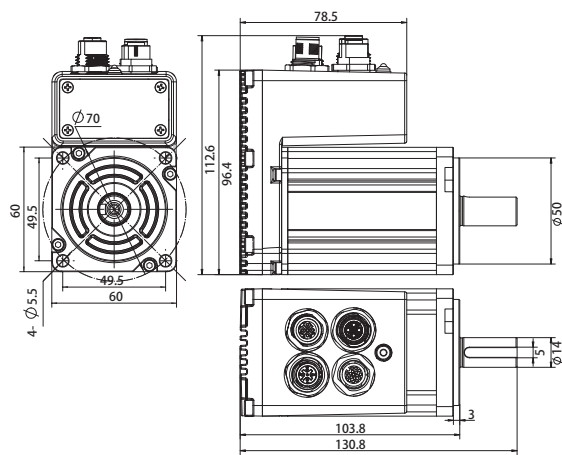

Torque Curves

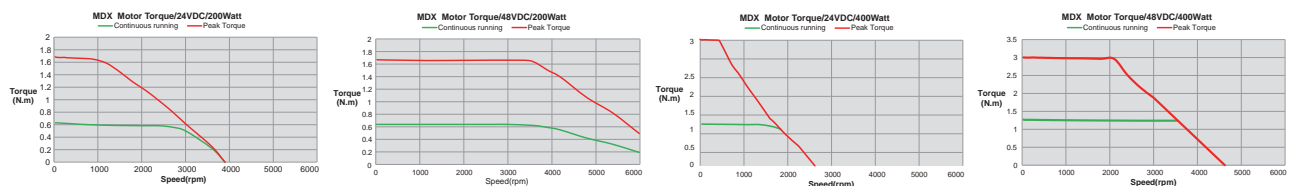

Descriptions—Low Profile Heat Sink — IP65 Type



- IP65 Rating
- Frame Size: 60mm
- Power Rating: 200W, 400W
- 5 Digital Inputs
- 4 Digital Outputs
- 2 Analog Inputs
- Support RS-485, CANopen
- With planetary gearbox

Part Number	Unit	MDXL61GN3□AP□□ MDXL61GNM□AP□□		MDXL62GN3□AP□□ MDXL62GNM□AP□□	
		24	48	24	48
Winding Type	VDC	48VDC		48VDC	
Nominal Supply Voltage	VDC	24	48	24	48
Nominal Speed	Rpm	2000	3000	1600	3000
Powe Rating (at 3000rpm)	W	200		400	
Motor Continuous Torque (Without gearbox)	N.m	0.64		1.27	
Motor Peak Torque (Without gearbox)	N.m	1.7		3.0	
Rotor Inertia	Kg-m ²	0.165 x 10 ⁻⁴		0.272 x 10 ⁻⁴	
Shaft Load - Axial	N (max.)	70		70	
Shaft Load - Radial (End of Shaft)	N (max.)	200		240	
Weight - Motor	kg	1.25		1.63	
Weight - Gearbox	kg	0.68(10:1), 0.97(20:1), 1.18(40:1)			
Gear Ratio	-	10:1, 20:1, 40:1			

Dimensions (Unit: mm)

- MDXL61GN3 □ AP □ □
- MDXL61GNM □ AP □ □

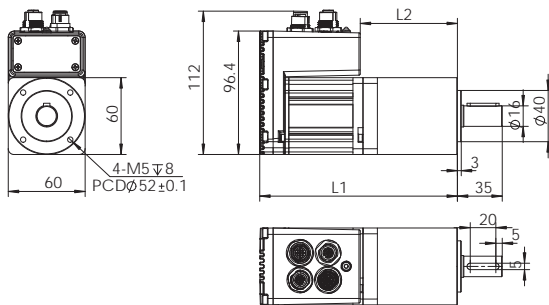

- MDXL62GN3 □ AP □ □
- MDXL62GNM □ AP □ □

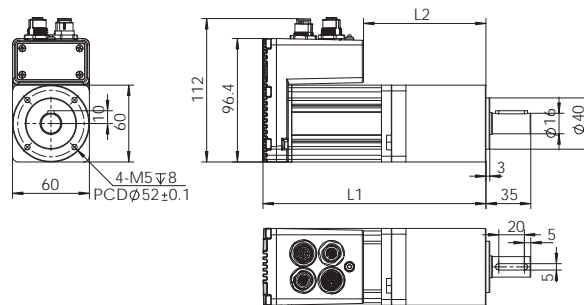

Model	L1	L2	Model	L1	L2
MDXL61GN□□AP10	139.6 ± 1	61.4 ± 1	MDXL62GN□□AP10	159.6 ± 1	81.4 ± 1
MDXL61GN□□AP20	154.1 ± 1	75.9 ± 1	MDXL62GN□□AP20	174.1 ± 1	95.9 ± 1
MDXL61GN□□AP40	154.1 ± 1	75.9 ± 1	MDXL62GN□□AP40	174.1 ± 1	95.9 ± 1

Torque Curves (Without Gearbox)

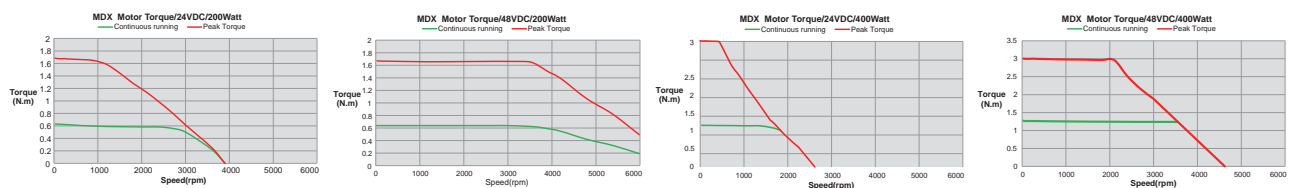

■ Descriptions—Standard Heat Sink — IP20 Type



- IP20 Rating
- Frame Size: 60mm
- Power Rating: 200W, 400W
- 8 Digital Inputs
- 4 Digital Outputs
- 2 Analog Inputs
- Support RS-485 or CANopen
- Without planetary gearbox
- Standard shaft with keyway

Part Number	Unit	MDXK61GN3□B000 MDXK61GNM□B000		MDXK62GN3□B000 MDXK62GNM□B000	
		24	48	24	48
Winding Type	VDC	48		48	
Nominal Supply Voltage	VDC	24	48	24	48
Rated Speed	Rpm	2000	3000	1600	3000
Power Rating (at 3000rpm)	W	200		400	
Motor Continuous Torque	N.m	0.64		1.27	
Motor Peak Torque	N.m	1.7		3.0	
Rotor Inertia	Kg-m ²	0.165 x 10 ⁻⁴		0.272 x 10 ⁻⁴	
Shaft Load - Axial	N (max.)	70		70	
Shaft Load - Radial (End of Shaft)	N (max.)	200		240	
Weight	kg	1.25		1.62	

Dimensions (Unit: mm)

- MDXK61GN3 □ B000
- MDXK61GNM □ B000

- MDXK62GN3 □ B000
- MDXK62GNM □ B000

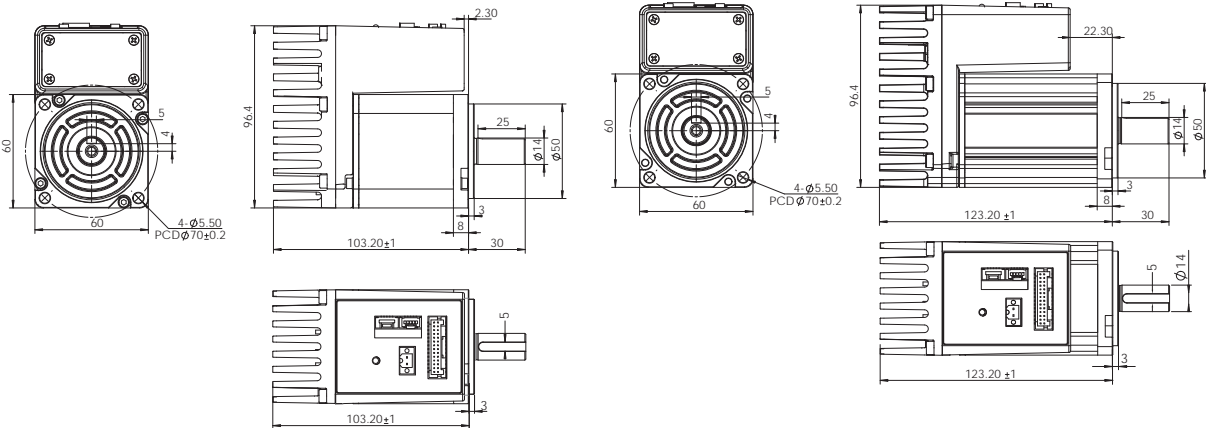

Torque Curves

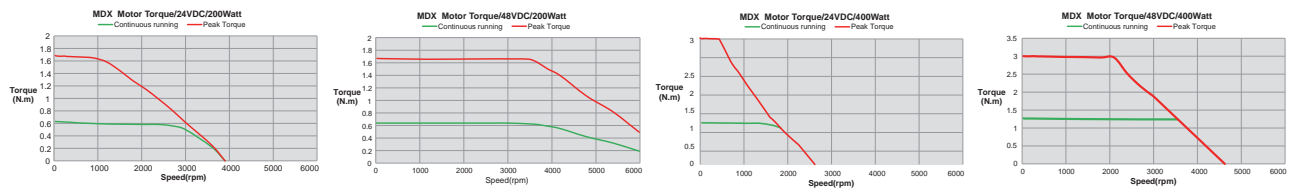

Descriptions—Standard Heat Sink — IP20 Type



- IP20 Rating
- Frame Size: 60mm
- Power Rating: 200W, 400W
- 8 Digital Inputs
- 4 Digital Outputs
- 2 Analog Inputs
- Support RS-485 or CANopen
- With planetary gearbox

Part Number	Unit	MDXK61GN3□BP□□ MDXK61GNM□BP□□		MDXK62GN3□BP□□ MDXK62GNM□BP□□	
		24	48	24	48
Winding Type	VDC	48VDC		48VDC	
Nominal Supply Voltage	VDC	24	48	24	48
Rated Speed	Rpm	2000	3000	1600	3000
Power Rating (at 3000rpm)	W	200		400	
Motor Continuous torque (Without Gearbox)	N.m	0.64		1.27	
Motor Peak Torque (Without Gearbox)	N.m	1.7		3.0	
Rotor Inertia	Kg-m ²	0.165 x 10 ⁻⁴		0.272 x 10 ⁻⁴	
Shaft Load - Axial	N (max.)	70		70	
Shaft Load - Radial (End of Shaft)	N (max.)	200		240	
Weight - Motor	kg	1.25		1.62	
Weight - Gearbox	kg	0.68(10:1), 0.97(20:1), 1.18(40:1)			
Gear Ratio	-	10:1, 20:1, 40:1			

Dimensions (Unit: mm)

- MDXK61GN3 □ BP □□
- MDXK61GNM □ BP □□

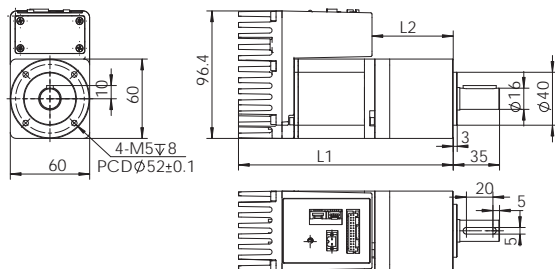

Model	L1	L2
MDXK61GN□□BP10	162.3 ± 1	61.4 ± 1
MDXK61GN□□BP20	176.8 ± 1	75.9 ± 1
MDXK61GN□□BP40	176.8 ± 1	75.9 ± 1

- MDXK62GN3 □ BP □□
- MDXK62GNM □ BP □□

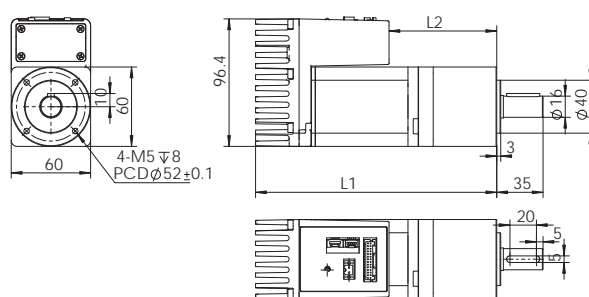

Model	L1	L2
MDXK62GN□□BP10	182.3 ± 1	81.4 ± 1
MDXK62GN□□BP20	196.8 ± 1	95.9 ± 1
MDXK62GN□□BP40	196.8 ± 1	95.9 ± 1

Torque Curves (Without gearbox)

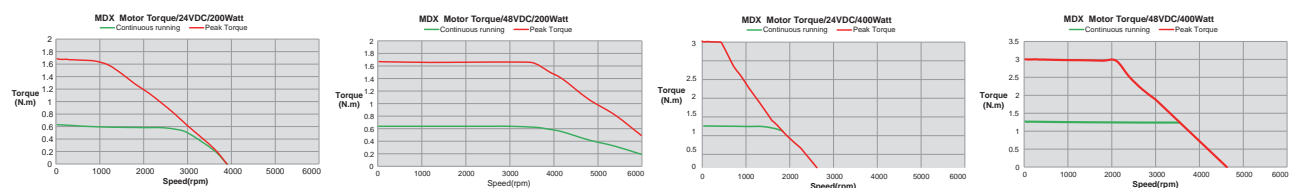

■ Descriptions—Standard Heat Sink — IP65 Type



- IP65 Rating
- Frame Size: 60mm
- Power Rating: 200W, 400W
- 5 Digital Inputs
- 4 Digital Outputs
- 2 Analog Inputs
- Support RS-485 or CANopen
- Without gearbox
- Standard Shaft with Keyway

Part Number	Unit	MDXL61GN3□B000 MDXL61GNM□B000		MDXL62GN3□B000 MDXL62GNM□B000	
		24	48	24	48
Winding Type	VDC	48VDC		48VDC	
Nominal Supply Voltage	VDC	24	48	24	48
Retard Speed	Rpm	2000	3000	1600	3000
Power Rating (at 3000rpm)	W	200		400	
Motor Continuous Torque	N.m	0.64		1.27	
Motor Peak Torque	N.m	1.7		3.0	
Rotor Inertia	Kg-m ²	0.165 x 10 ⁻⁴		0.272 x 10 ⁻⁴	
Shaft Load - Axial	N (max.)	70		70	
Shaft Load - Radial (End of Shaft)	N (max.)	200		240	
Weight	kg	1.32		1.70	

Dimensions (Unit: mm)

- MDXL61GN3 □ B000
- MDXL61GNM □ B000

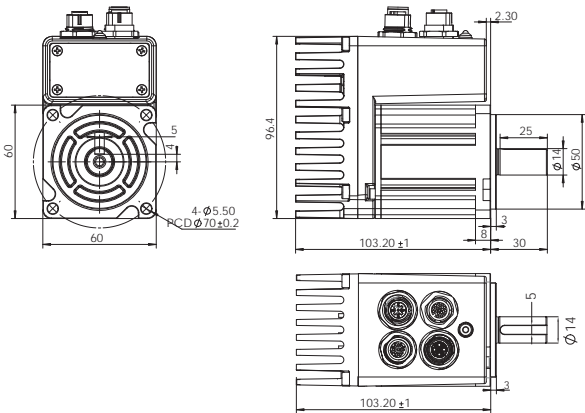

- MDXL62GN3 □ B000
- MDXL62GNM □ B000

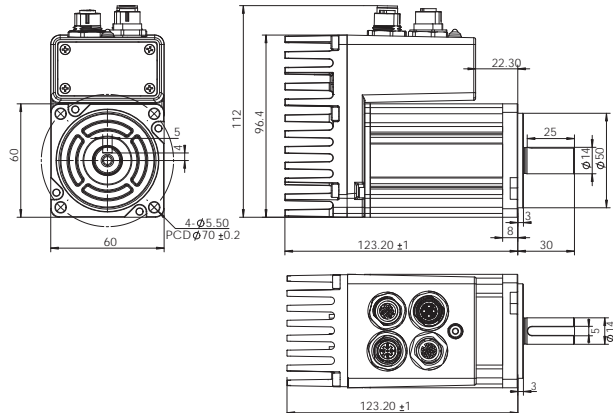

Torque Curves

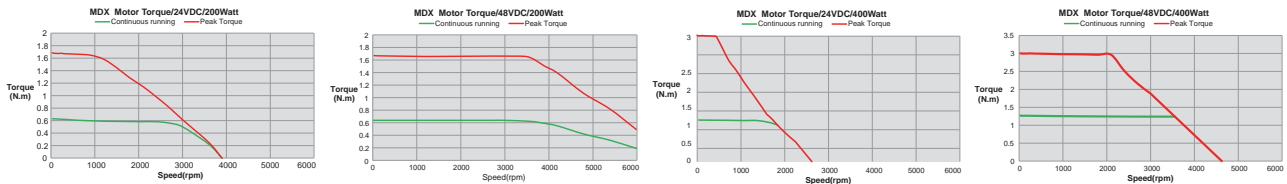

■ Descriptions—Standard Heat Sink — IP65 Type



- IP65 Rating
- Frame Size: 60mm
- Power Rating: 200W, 400W
- 5 Digital Inputs
- 4 Digital Outputs
- 2 Analog Inputs
- Support RS-485, CANopen
- With planetary gearbox

Part Number	Unit	MDXL61GN3□BP□□ MDXL61GNM□BP□□		MDXL62GN3□BP□□ MDXL62GNM□BP□□	
		24	48	24	48
Winding Type	VDC	48VDC		48VDC	
Nominal Supply Voltage	VDC	24	48	24	48
Nominal Speed	Rpm	2000	3000	1600	3000
Powe Rating (at 3000rpm)	W	200		400	
Motor Continuous Torque (Without gearbox)	N.m	0.64		1.27	
Motor Peak Torque (Without gearbox)	N.m	1.7		3.0	
Rotor Inertia	Kg·m ²	0.165 x 10 ⁻⁴		0.272 x 10 ⁻⁴	
Shaft Load - Axial	N (max.)	70		70	
Shaft Load - Radial (End of Shaft)	N (max.)	200		240	
Weight - Motor	kg	1.32		1.70	
Weight - Gearbox	kg	0.68(10:1), 0.97(20:1), 1.18(40:1)			
Gear Ratio	-	10:1, 20:1, 40:1			

Dimensions (Unit: mm)

- MDXL61GN3 □ BP □□
- MDXL61GNM □ BP □□

- MDXL62GN3 □ BP □□
- MDXL62GNM □ BP □□

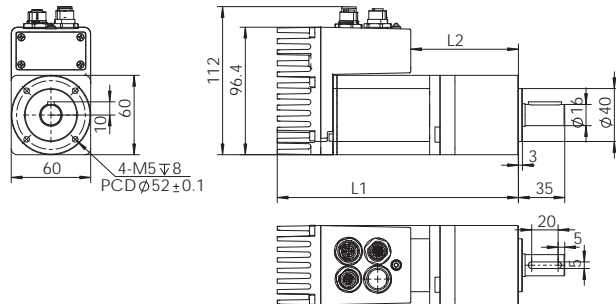
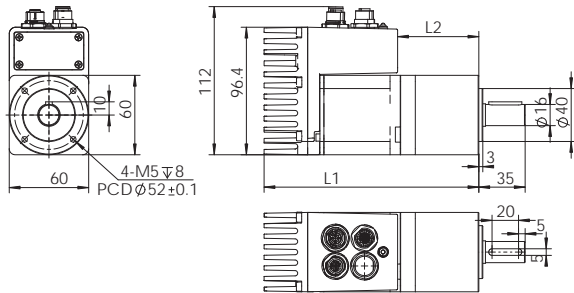

Model	L1	L2
MDXL61GN□□BP10	162.3 ± 1	61.4 ± 1
MDXL61GN□□BP20	176.8 ± 1	75.9 ± 1
MDXL61GN□□BP40	176.8 ± 1	75.9 ± 1

Model	L1	L2
MDXL62GN□□BP10	182.3 ± 1	81.4 ± 1
MDXL62GN□□BP20	196.8 ± 1	95.9 ± 1
MDXL62GN□□BP40	196.8 ± 1	95.9 ± 1

Torque Curves (Without Gearbox)

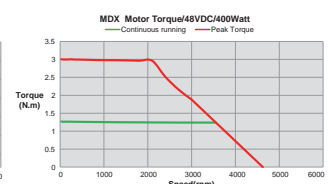
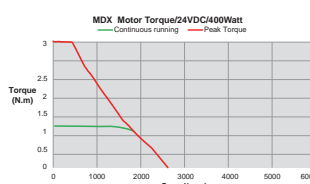
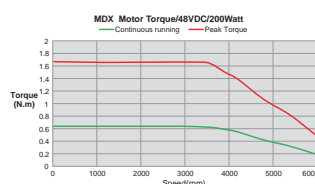
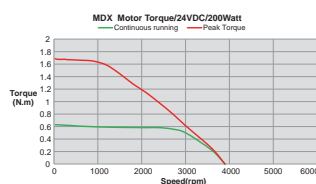

System Configuration

IP65 Type

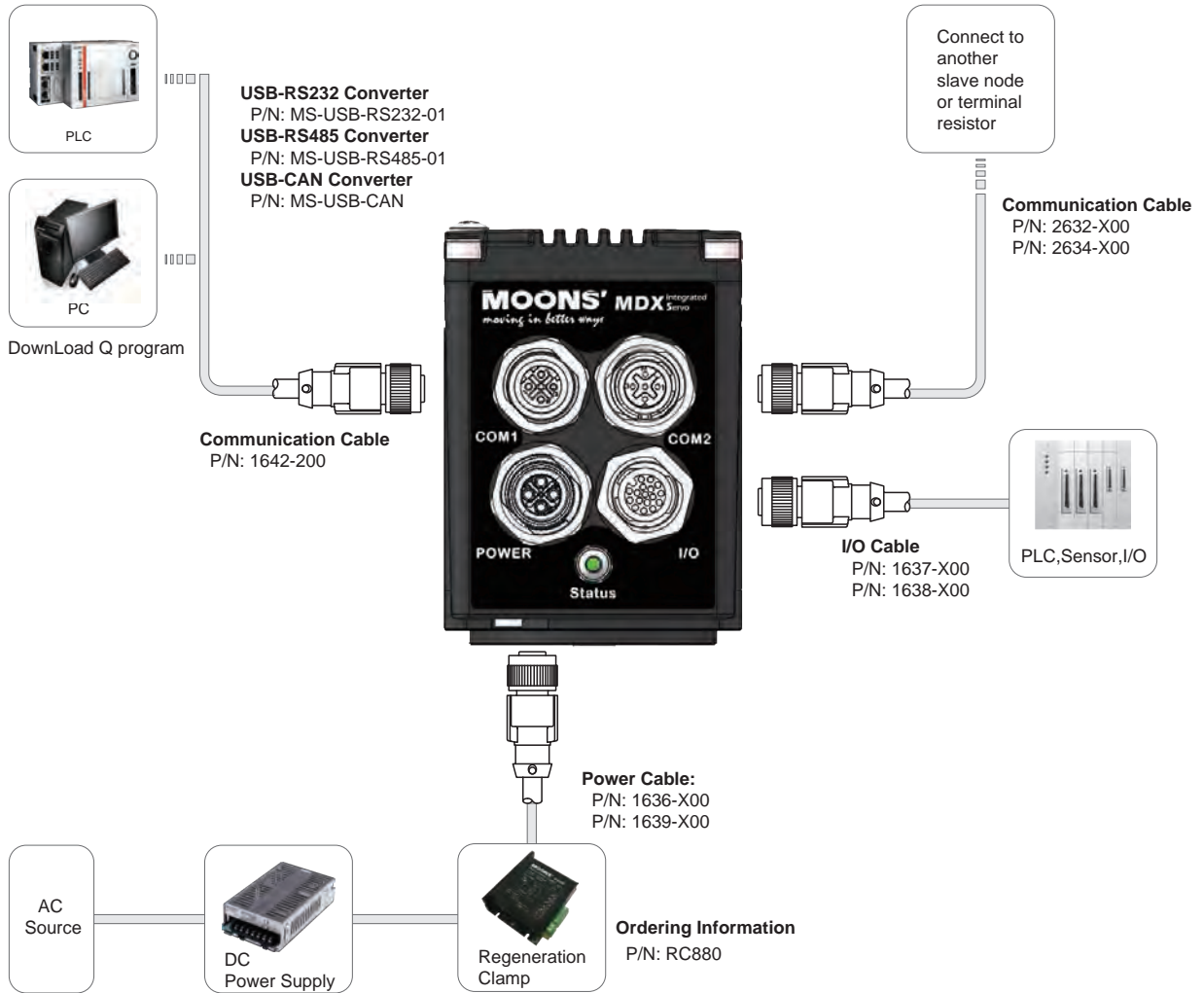

Accessories

I/O Cable

Right Angle Type

P/N	Length(L)
1637-100	1m
1637-200	2m

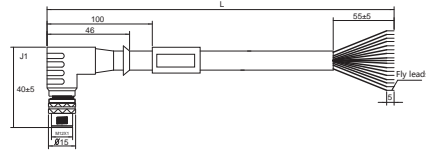

Straight Type

P/N	Length(L)
1638-100	1m
1638-200	2m

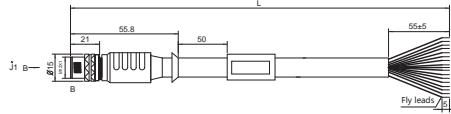

J1 Pin	Colour	J1 Pin	Colour
1	Brown(STEP+)	11	Gray/Pink(Y1)
3	White(STEP-)	12	Red/Blue(Y2)
6	Yellow(DIR+)	13	White/Green(Y3)
4	Green(DIR-)	2	Blue(Y4)
5	Pink/Red(X3)	14	Brown/Green(YCOM)
8	Gray(X4)	15	White/Yellow(DGND)
7	Black(X5)	16	Yellow/Brown(AIN2)
10	Purple(NC)	17	White/Gray(AIN1)
9	Red(XCOM)		

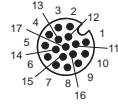

Power Cable

Right Angle Type

P/N	Length(L)
1636-100	1m
1636-200	2m
1636-300	3m
1636-500	5m

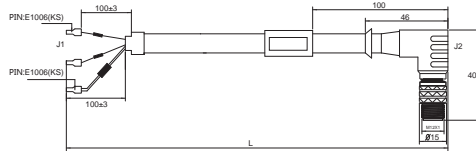

Straight Type

P/N	Length(L)
1639-100	1m
1639-200	2m
1639-300	3m
1639-500	5m

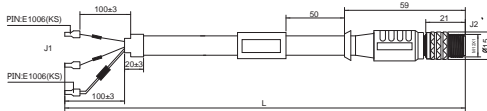

J1 Pin	J2 Pin	Function	Colour
1	1	V+	Red
2	2	V-	Yellow
3	3	NC	
4	4	NC	
shield		shield	Heat Shrink



Communication Cable

Right Angle Type

P/N	Length(L)
2632-100	1m
2632-200	2m
2632-300	3m
2632-500	5m

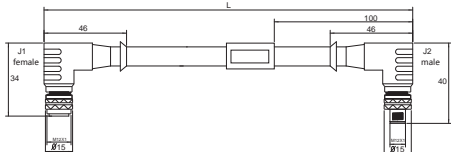

Straight Type

P/N	Length(L)
2634-100	1m
2634-200	2m
2634-300	3m
2634-500	5m

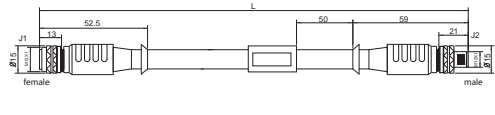

J1 Pin	RS485	CAN
1	Brown(RX+)	Brown(RS232 TX)
2	white(RX-)	white(RS232 RX)
3	Blue(TX+)	Blue(GND)
4	Black(TX-)	Black(CAN-H)
5	Yellow/Green(GND)	Yellow/Green(CAN-L)
J2 Pin	RS485	CAN
1	Brown(RX+)	Brown(N/C)
2	white(RX-)	white(N/C)
3	Blue(TX+)	Blue(GND)
4	Black(TX-)	Black(CAN-H)
5	Yellow/Green(GND)	Yellow/Green(CAN-L)

Communication Cable (COM1)

P/N	Length(L)
1642-200	2m

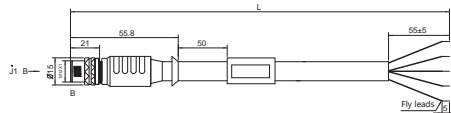

J1	RS485	CAN
1	Brown(RX+)	Brown(RS232 TX)
2	white(RX-)	white(RS232 RX)
3	Blue(TX+)	Blue(GND)
4	Black(TX-)	Black(CAN-H)
5	Yellow/Green(GND)	Yellow/Green(CAN-L)

Plastic protection cap

P/N	Description
MDX-M12S	For Power, I/O and COM1 connectors
MDX-M12K	For COM2 connector

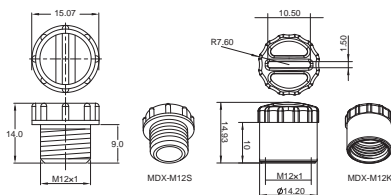

Terminal resistor

P/N	Description
MDX-FKTR	For CANopen COM2, IP65
MDX-MZTR	For CANopen COM1, IP65
MDX-FRTR	For RS485 COM2, IP65
MDX-MRTR	For RS485 COM1, IP65

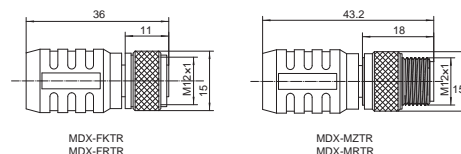

System Configuration

IP20 Type

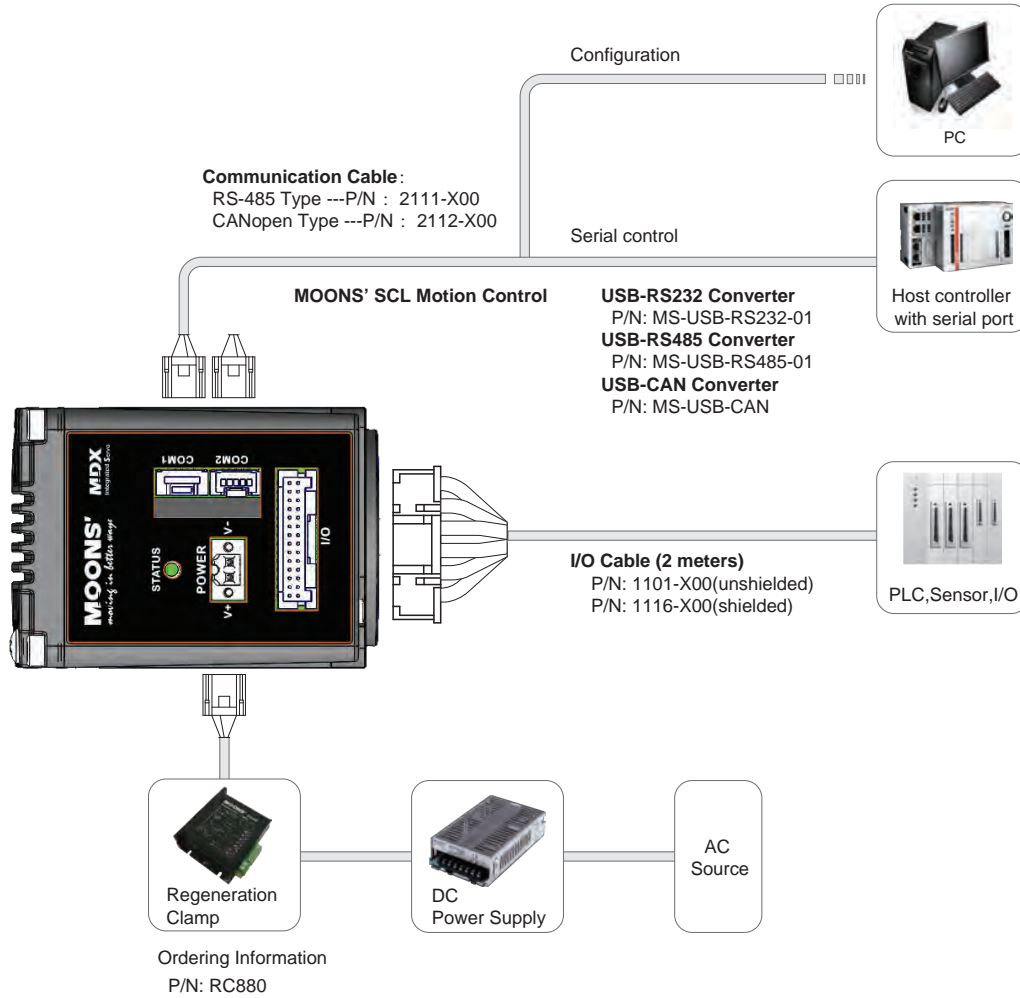

Accessories

◇ General Purpose I/O Cable(unshielded)

P/N	Length (L)
1101-100	1m
1101-200	2m
1101-500	5m

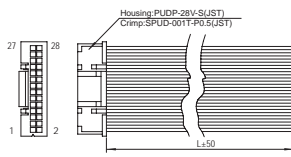

Pin No.	Assignment	Description	Color
1	X1+	High Speed Digital Input	BLU
2	X1-		BLU/WHT
3	X2+	High Speed Digital Input	YEL
4	X2-		YEL/WHT
5	X3	X3 Digital Input	GRN
6	X4	X4 Digital Input	ORG
7	X5	X5 Digital Input	GRY
8	X6	X6 Digital Input	PUR
9	XCOM	X Digital Input COM	WHT
10	+5V	+5VDC Output	RED
11	AIN1	Analog Input 1	BLU
12	GND	Analog Input Ground	BLK
13	X7+	X7 Digital Input	ORG
14	X7-		ORG/WHT
15	X8+	X8 Digital Input	GRN
16	X8-		GRN/WHT
17	Y1	Y1 Digital Output	BLU
18	Y2	Y2 Digital Output	YEL
19	Y3	Y3 Digital Output	BRN
20	YCOM	Y Output COM	BLK
21	Y4	Y4 Digital Output	RED
22	AIN2	Analog Input 2	RED/WHT
23	Z+	Encoder Output Z	BLK
24	Z-		BLK/WHT
25	B+	Encoder Output B	GRN
26	B-		GRN/WHT
27	A+	Encoder Output A	ORG
28	A-		ORG/WHT

◇ General Purpose I/O Cable(shielded)

P/N	Length (L)
1116-100	1m
1116-200	2m
1116-300	3m
1116-500	5m

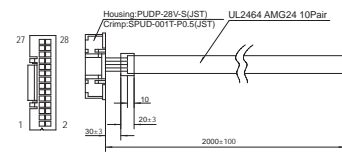

Pin No.	Assignment	Description	Color
1	X1+	High Speed Digital Input	BLU/WHT
2	X1-		BLU/BLK
3	X2+	High Speed Digital Input	GRN/WHT
4	X2-		GRN/BLK
5	X3	X3 Digital Input	BLU
6	X4	X4 Digital Input	PUR
7	X5	X5 Digital Input	YEL
8	X6	X6 Digital Input	GRN
9	XCOM	X Digital Input COM	ORG
10	+5V	+5VDC Output	RED
11	AIN	Analog Input	WHT
12	GND	Analog Input Ground	BLK
13	X7+	X7 Digital Input	BRN/WHT
14	X7-		BRN/BLK
15	X8+	X8 Digital Input	GRY/WHT
16	X8-		GRY/BLK
17	Y1	Y1 Digital Output	BRN
18	Y2	Y2 Digital Output	GRY
19	Y3	Y3 Digital Output	PNK
20	YCOM	Y Output COM	YEL/GRN
21	Y4	Y4 Digital Output	PUR/WHT
22	AIN2	Analog Input 2	PUR/BLK
23	Z+	Encoder Output Z	YEL/WHT
24	Z-		YEL/BLK
25	B+	Encoder Output B	ORG/WHT
26	B-		ORG/BLK
27	A+	Encoder Output A	RED/WHT
28	A-		RED/BLK

◇ RS-485 Daisy Chain Communication Cable

P/N	Length (L)
2111-025	0.25m
2111-050	0.5m
2111-100	1m
2111-300	3m

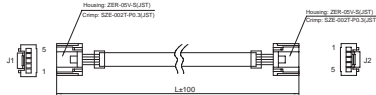

◇ CANopen Daisy Chain Communication Cable

P/N	Length (L)
2112-025	0.25m
2112-050	0.5m
2112-100	1m
2112-300	3m

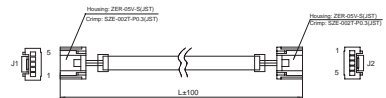

◇ RS-232 Communication Cable(C Type)

P/N	Length (L)
2113-150	1.5m

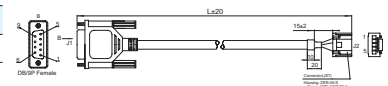

◇ Regeneration Clamp

P/N: RC880

When using regulated power supply you may encounter a problem with regeneration. The kinetic energy caused by regeneration is transferred back to the power supply. This can trip the overvoltage protection of a switching power supply, causing it to shut down.

MOONS' offer the RC880 "regeneration clamp" to solve this problem. If in doubt, use an RC880 for your first installation. If the "regen" LED on the RC880 never flashes, you don't need the clamp.

Dimensions(Unit:mm)

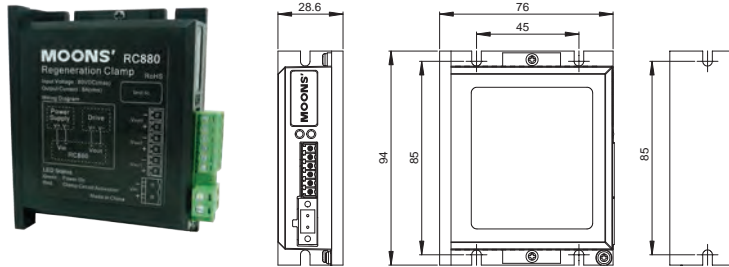

■ **How To Choose Low Profile Sink Drive and Standard Sink Drive**

Low Profile Sink Type

The low profile sink type was designed for compact and space-saving, which is suitable for mounting to a tightly constrained space as the overall length of the drive is nearly 23mm shorter than the Standard type. Due to the limited heat dissipation area, please consider about working duty cycle based on the ambient temperature, continuous running current.

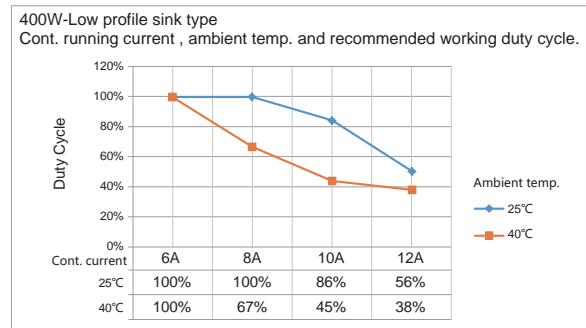
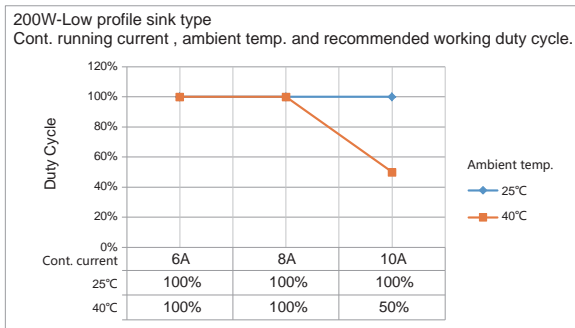

Standard Sink Type

The standard sink type drive can work better on the more stringer conditions due to its bigger heat dissipation area. Please refer the following information.

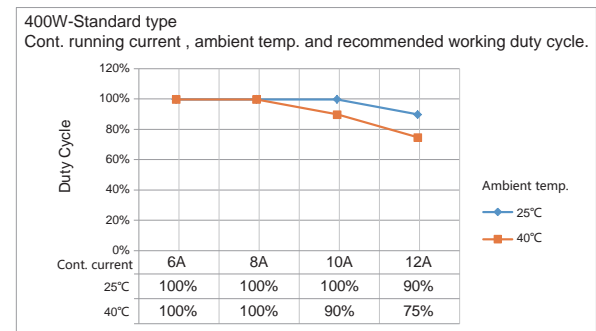
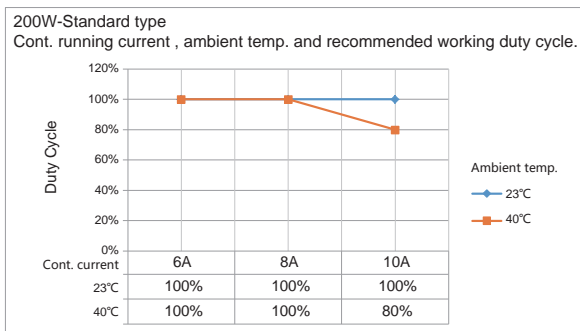

■ Ordering Information (Low Profile Heat Sink)

Part Number		Power Rating	IP Rating	RS-485	CANopen	Gear Ratio	
16-bit magnetic encoder	1024 Lines magnetic encoder						
MDXK61GN3RA000	MDXK61GNMRA000	200	IP20	✓		N/A	
MDXK62GN3RA000	MDXK62GNMRA000	400		✓		N/A	
MDXK61GN3CA000	MDXK61GNMCA000	200			✓	N/A	
MDXK62GN3CA000	MDXK62GNMCA000	400			✓	N/A	
MDXK61GN3RAP10	MDXK61GNMRAP10	200		✓		10:1	
MDXK61GN3RAP20	MDXK61GNMRAP20			✓		20:1	
MDXK61GN3RAP40	MDXK61GNMRAP40			✓		40:1	
MDXK61GN3CAP10	MDXK61GNMCAP10				✓	10:1	
MDXK61GN3CAP20	MDXK61GNMCAP20				✓	20:1	
MDXK61GN3CAP40	MDXK61GNMCAP40				✓	40:1	
MDXK62GN3RAP10	MDXK62GNMRAP10	400		✓		10:1	
MDXK62GN3RAP20	MDXK62GNMRAP20			✓		20:1	
MDXK62GN3RAP40	MDXK62GNMRAP40			✓		40:1	
MDXK62GN3CAP10	MDXK62GNMCAP10				✓	10:1	
MDXK62GN3CAP20	MDXK62GNMCAP20				✓	20:1	
MDXK62GN3CAP40	MDXK62GNMCAP40				✓	40:1	
MDXL61GN3RA000	MDXL61GNMRA000	200		IP65	✓		N/A
MDXL62GN3RA000	MDXL62GNMRA000	400			✓		N/A
MDXL61GN3CA000	MDXL61GNMCA000	200				✓	N/A
MDXL62GN3CA000	MDXL62GNMCA000	400				✓	N/A
MDXL61GN3RAP10	MDXL61GNMRAP10	200	✓			10:1	
MDXL61GN3RAP20	MDXL61GNMRAP20		✓			20:1	
MDXL61GN3RAP40	MDXL61GNMRAP40		✓			40:1	
MDXL61GN3CAP10	MDXL61GNMCAP10				✓	10:1	
MDXL61GN3CAP20	MDXL61GNMCAP20				✓	20:1	
MDXL61GN3CAP40	MDXL61GNMCAP40				✓	40:1	
MDXL62GN3RAP10	MDXL62GNMRAP10	400	✓			10:1	
MDXL62GN3RAP20	MDXL62GNMRAP20		✓			20:1	
MDXL62GN3RAP40	MDXL62GNMRAP40		✓			40:1	
MDXL62GN3CAP10	MDXL62GNMCAP10				✓	10:1	
MDXL62GN3CAP20	MDXL62GNMCAP20				✓	20:1	
MDXL62GN3CAP40	MDXL62GNMCAP40				✓	40:1	

■ **Ordering Information (Standard Heat Sink)**

Part Number		Power Rating	IP Rating	RS-485	CANopen	Gear Ratio	
16-bit magnetic encoder	1024 Lines magnetic encoder						
MDXK61GN3RB000	-	200	IP20	✓		N/A	
MDXK62GN3RB000	-	400		✓		N/A	
MDXK61GN3CB000	-	200			✓	N/A	
MDXK62GN3CB000	-	400			✓	N/A	
MDXK61GN3RBP10	-	200		✓		10:1	
MDXK61GN3RBP20	-			✓		20:1	
MDXK61GN3RBP40	-			✓		40:1	
MDXK61GN3CBP10	-				✓	10:1	
MDXK61GN3CBP20	-				✓	20:1	
MDXK61GN3CBP40	-				✓	40:1	
MDXK62GN3RBP10	-	400		✓		10:1	
MDXK62GN3RBP20	-			✓		20:1	
MDXK62GN3RBP40	-			✓		40:1	
MDXK62GN3CBP10	-				✓	10:1	
MDXK62GN3CBP20	-				✓	20:1	
MDXK62GN3CBP40	-				✓	40:1	
MDXL61GN3RB000	-	200		IP65	✓		N/A
MDXL62GN3RB000	-	400			✓		N/A
MDXL61GN3CB000	-	200				✓	N/A
MDXL62GN3CB000	-	400				✓	N/A
MDXL61GN3RBP10	-	200	✓			10:1	
MDXL61GN3RBP20	-		✓			20:1	
MDXL61GN3RBP40	-		✓			40:1	
MDXL61GN3CBP10	-				✓	10:1	
MDXL61GN3CBP20	-				✓	20:1	
MDXL61GN3CBP40	-				✓	40:1	
MDXL62GN3RBP10	-	400	✓			10:1	
MDXL62GN3RBP20	-		✓			20:1	
MDXL62GN3RBP40	-		✓			40:1	
MDXL62GN3CBP10	-				✓	10:1	
MDXL62GN3CBP20	-				✓	20:1	
MDXL62GN3CBP40	-				✓	40:1	

■ Connection and Operation(IP20 Type)

◇ Descriptions Parts

MDX Series IP20 Type

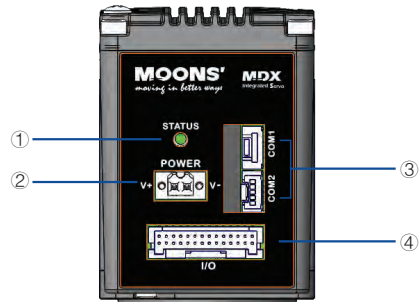

① LED Displays

■ LED Error Codes

MDX series use a bi-color LED indicator to indicate status. When the motor is enabled, the green LED flashes slowly. When the green LED is solid, the motor is disabled. Errors are indicated by combinations of red and green flashes as shown in [Page of Alarm information](#).

② Power Connector

PN: Weidmuller 1615780000

	Description
+	Power Supply +
-	Power Supply -

③ Communication Connector

Housing P/N: JST ZER-05V-S
Crimp P/N: JST SZE-002T-PO.3

CANopen Type

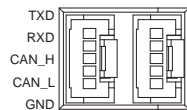

COM1		COM2	
Pin.	Description	Pin.	Description
TXD	RS232 Data Transmit	N/A	N/A
RXD	RS232 Data Receive	N/A	N/A
CAN_H	CAN+	CAN_H	CAN+
CAN_L	CAN-	CAN_L	CAN-
GND	Ground	GND	Ground

RS485 Type

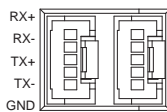

Pin.	Description
RX+	Receive+
RX-	Receive-
TX+	Send+
TX-	Send-
GND	Ground

④ Tybe I/O Signal Connector

Housing P/N: JST PUDP-28V-S
Crimp P/N: JST SPUD-001T-P0.5

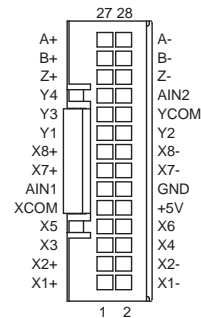

Pin no.	Assignment	Description
1	X1+/STEP+	High Speed Digital Input 1
2	X1-/STEP-	
3	X2+/DIR+	High Speed Digital Input 2
4	X2-/DIR-	
5	X3	X3 Digital Input
6	X4	X4 Digital Input
7	X5	X5 Digital Input
8	X6	X6 Digital Input
9	XCOM	Digital Input COM
10	+5	+5V OUT 100mA max.
11	AIN	Analog Input
12	GND	Analog Ground
13	X7+	X7 Digital Input
14	X7-	
15	X8+	X8 Digital Input
16	X8-	
17	Y1	Y1 Digital Output
18	Y2	Y2 Digital Output
19	Y3	Y3 Digital Output
20	YCOM	Digital Output COM
21	Y4	Y4 Digital Output
22	AIN2	Analog Input 2
23	Z+	Encoder Output Z
24	Z-	
25	B+	Encoder Output B
26	B-	
27	A+	Encoder Output A
28	A-	

■ Connection and Operation(IP65 Type)

◇ Descriptions of Parts

MDX Series IP65 Type



① LED Displays

■ LED Error Codes

MDX series use a bi-color LED indicator to indicate status. When the motor is enabled, the green LED flashes slowly. When the green LED is solid, the motor is disabled. Errors are indicated by combinations of red and green flashes as shown in [Page of Alarm information](#).

② Power Connector

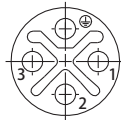

Pin	Signal
1	V+(Power Supply +)
2	V-(Power Supply -)
3	NC
4	NC

③ and ④ Communication Connector

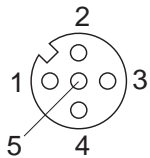

- 1.BN
- 2.WH
- 3.BU
- 4.BK
- 5.GY

The M12 COM1 CONN Diagram

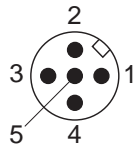

- 1.BN
- 2.WH
- 3.BU
- 4.BK
- 5.GY

The M12 COM2 CONN Diagram

MDX COM1 CONN		MDX COM2 CONN	
Pin	Signal	Pin	Signal
1	Receive Data RX+	1	Receive Data RX+
2	Receive Data RX-	2	Receive Data RX-
3	Transmit Data TX+	3	Transmit Data TX+
4	Transmit Data TX-	4	Transmit Data TX-
5	Reference GND	5	Reference GND

MDX COM1 CONN		MDX COM2 CONN	
Pin	Signal	Pin	Signal
1	RS232 Transmit TX	1	NC
2	RS232 Receive RX	2	NC
3	Reference GND	3	Reference GND
4	CAN_H	4	CAN_H
5	CAN_L	5	CAN_L

⑤ Tybe I/O Signal Connector

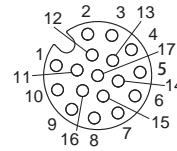

Pin no.	Assignment	Description
1	X1+/STEP+	High Speed Digital Input1
3	X1-/STEP-	
6	X2+/DIR+	High Speed Digital Input2
4	X2-/DIR-	
5	X3	X3 Digital Inpu
8	X4	X4 Digital Input
7	X5	X5 Digital Input
9	XCOM	Digital Input COM
11	Y1	Y1 Digital Output
12	Y2	Y2 Digital Output
13	Y3	Y3 Digital Output
2	Y4	Y4 Digital Output
14	YCOM	Digital Output COM
10	NC	NC
16	AIN2	Analog Input 2
17	AIN1	Analog Input 1
15	GND	

◇ Wiring Diagram

● MDX Series IP20 Type

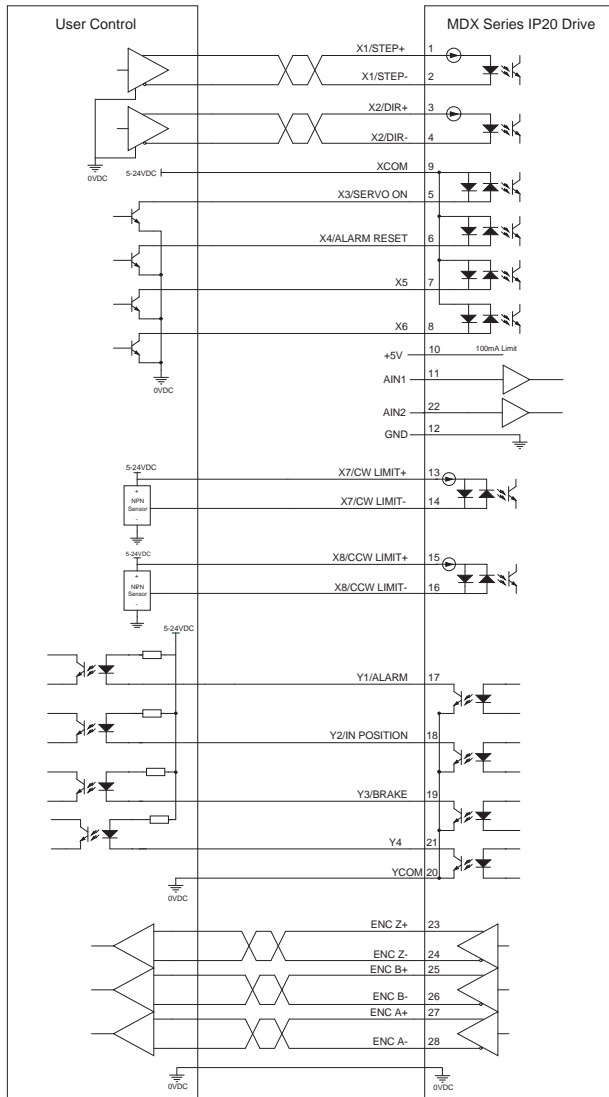

● MDX Series IP65 Type

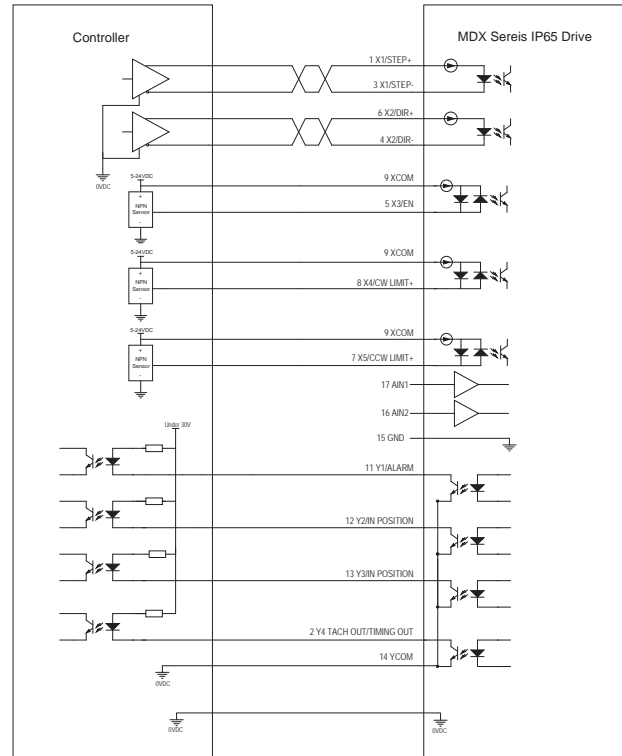



Distributors for Australia & New Zealand
MOTION TECHNOLOGIES PTY LIMITED



24/22-30 Northumberland Road
Caringbah NSW 2229 Australia
Phone: (02) 9524 4782

sales@motiontech.com.au
www.motiontech.com.au

© 10/07/2023