

Kollmorgen Direct Drive Linear Motor Selection Guide



www.motiontech.com.au

KOLLMORGEN®

Because Motion Matters™

Kollmorgen.

Every solution comes from a real understanding of the challenges facing machine designers and users.

The ever-escalating demands of the marketplace mean increased pressure on machine designers and users at every turn. Time constraints. Demands for better performance. Having to think about the next-generation machine even before the current one is built. While expectations are enormous, budgets are not. Kollmorgen's innovative motion solutions and broad range of quality products help engineers not only overcome these challenges but also build truly differentiated machines.

Because motion matters, it's our focus. Motion can distinctly differentiate a machine and deliver a marketplace advantage by improving its performance. This translates to overall increased efficiency on the factory floor. Perfectly deployed machine motion can make your customer's machine more reliable and efficient, enhance accuracy and improve operator safety. Motion also represents endless possibilities for innovation. We've always understood this potential, and thus have kept motion at our core, relentlessly developing products that offer precision control of speed, accuracy and position in machines that rely on complex motion.

Removing the Barriers of Design, Sourcing, and Time

At Kollmorgen, we know that OEM engineers can achieve a lot more when obstacles aren't in the way. So, we knock them down in three important ways:

Integrating Standard and Custom Products

The optimal solution is often not clear-cut. Our application expertise allows us to modify standard products or develop totally custom solutions across our whole product portfolio so that designs can take flight.

Providing Motion Solutions, Not Just Components

As companies reduce their supplier base and have less engineering manpower, they need a total system supplier with a wide range of integrated solutions. Kollmorgen is in full response mode with complete solutions that combine programming software, engineering services and best-in-class motion components.

Global Footprint

With direct sales, engineering support, manufacturing facilities, and distributors spanning the Americas, Europe, Middle East, and Asia, we're close to OEMs worldwide. Our proximity helps speed delivery and lend support where and when they're needed.

Financial and Operational Stability

Kollmorgen is part of Danaher Corporation. A key driver in the growth of all Danaher divisions is the Danaher Business System, which relies on the principle of "kaizen" – or continuous improvement. Using world-class tools, cross-disciplinary teams of exceptional people evaluate processes and develop plans that result in superior performance.

Table of Contents

▶ Direct Drive Linear (DDL) Motor	4
▶ AKD™ Servo Drive	10
▶ Co-Engineering Capabilities	14
▶ Direct Drive Linear Motor Summary	15
▶ DDL Ironless - Non-cooled Data and Dimensions	
IL06 Series	18
IL12 Series	20
IL18 Series	22
IL24 Series	26
▶ Ironless Magnet Ways	28
▶ DDL Ironcore Data and Dimensions	
ICD05 Series	32
ICD10 Series	34
▶ ICD Magnet Ways	36
▶ DDL Ironcore - Non-cooled Data and Dimensions	
IC11 Series	40
IC22 Series	42
IC33 Series	46
IC44 Series	50
▶ DDL Ironcore - Water-cooled Data and Dimensions	
IC11 Series	54
IC22 Series	56
IC33 Series	60
IC44 Series	64
▶ Ironcore Magnet Ways	68
▶ Wiring and Output	70
▶ High Flex Cable Sets	72
▶ Application Sizing	74
▶ Model Nomenclature	78
▶ MOTIONEERING® Application Engine	81

Direct Drive Linear Motor

Our direct drive linear motor series provide new dimension in performance with high throughput, accuracy, and zero maintenance. The product line are frameless, permanent magnet, three phase, brushless servomotors. The product line consists of two fundamental constructions, Ironless (slotless) and Ironcore. Ironless motors have no attractive force between the frameless components and zero cogging for the ultra smooth motion. Ironcore motors provide the highest force per frame size. They feature a patented anti-cogging design which yields extremely smooth operation.

The Benefits of Direct Drive Linear Motor

- Zero Maintenance with Greater Accuracy and Higher Bandwidth
 - Smoother velocity and reduced audible noise
 - Power transmission without backlash
 - Transmission elements such as couplings, toothed belts, ball/lead screws, rack & pinions, and other fitted components can be eliminated
 - No gears or screws, no lubrication required
 - Improved machine reliability
- Wide Range of Sizes and Force to Cover any Linear Application
 - Increased performance for the entire system
 - Flat, compact drive solution
 - Easily mix / match motors and drives
 - Real-life acceleration up to 10 G
- Simplified, High Force Permanent Magnet Design
 - Higher bandwidth and faster response than ball/lead screws or rack & pinion solutions
 - Rapid indexing of heavy loads with peak force up to 12,500 N (2,800 lb)
 - Reduced audible noise, fewer parts and lower cost of ownership
 - More compact machine design

Direct Drive Linear Motor Overview

Kollmorgen Direct Drive Linear DDL Motor Series

Kollmorgen supplied its first linear motors in the late 1970's for use in precision X-Y tables and coating systems. These were brush DC motors using the Kollmorgen patented push-through commutator bar method. This led to development in the early 1980's of the brushless versions of the linear motor which were used in film processing applications where smooth, high stiffness, linear motion was required. During the past 30 years, advances in permanent magnet material, power semiconductors, and microprocessor technology have been the enablers for increased performance and lower costs for linear motors.

DDL motors series comply with the Low Voltage Directive 73/23/EEC for installation in a machine. Safety depends upon installing and configuring motor per the manufacturer's recommendations. The machine in which this product is to be installed must conform to the provisions of EC directive 89/336/EEC. The installer is responsible for ensuring that the end product complies with all the relevant laws in the country where the equipment is installed.

Standard Product Features

Ironless:

- Peak force 60 to 1600 N (13.6 to 360 lbf)
- Continuous force 21 to 450 N (4.6 to 101lbf)
- Zero cogging
- Zero attractive force
- Smooth motion for speed as low as 1 micron/second (0.00004 in/sec)
- Low mass coil assembly for high acceleration

Ironcore:

- Peak force IC series: 320 to 8407 N (71.9 to 1890 lbf)
- Continuous force IC series: 144 to 6916 N (32.4 to 1555 lbf)
- Peak force ICD series: 165 to 1099 N (38 to 254 lbf)
- Continuous force ICD series: 57.0 to 315 N (12.8 to 70.8 lbf)
- Patented anti-cogging technique for minimal cogging without magnet skewing
- High motor constant (Km)
- High force density
- ICD series advantage:
 - Very low profile
 - Low attraction force
 - Suitable to replace many Ironless applications

All Motors:

- Zero contact, zero maintenance, brushless design
- 3 phase sinusoidal commutation
- Peak accelerations easily above 10 G
- High position accuracy and resolution
- Very low settling time
- Low thermal losses
- Modular magnet design

Standard Options:

- Hall effect feedback
- Thermal protection
 - Thermistor
 - Thermostat (Ironcore)
- Supplemental air or water cooling (Ironcore)
- Cable options
- Magnet way covers for easy cleaning (Ironcore)
- FM approved, hazardous environment

Our Direct Drive Linear (DDL) motor series are frameless permanent magnet, three phase brushless servomotors. Fundamentally, a linear motor is a rotary motor that is rolled out flat.



**Direct Drive Linear Motor Series
with AKD Servo Drive**

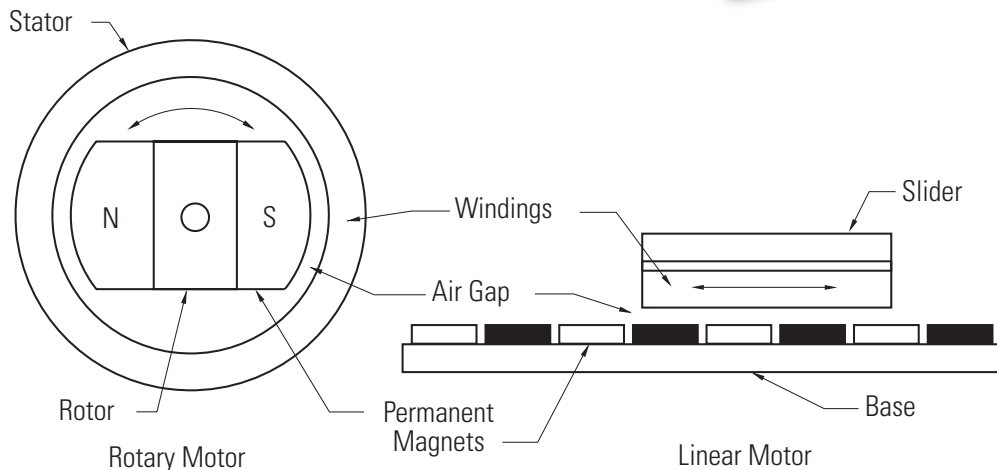

Rotary Motor Rolled Out Flat

The two primary components of permanent magnet brushless rotary motors are the stator (primary coils) and the rotor (secondary or rotating magnets). In brushless linear motors the rotor is rolled out flat to become the magnet track (also called the magnet way). The primary coils of the rotary motor are rolled out flat to become the coil assembly (also sometimes called the slider).

In most brushless linear motor applications it is typical for the magnet way to be stationary and the coil assembly to be in motion, because of the relative masses of the two components. But it is also perfectly acceptable and sometimes advantageous to reverse this arrangement. The basic electromagnetic operating principles are the same in either case and are identical to those of a rotary motor.

Direct Drive Linear Motor Overview

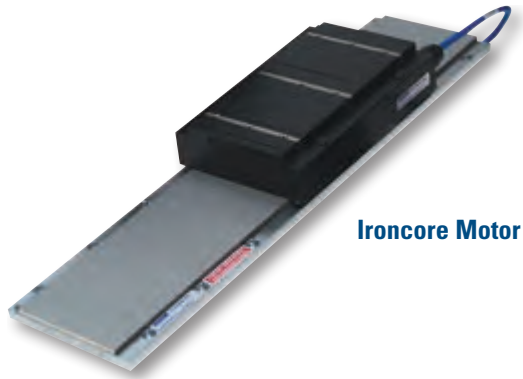

Ironcore Motor



Ironless Motor

Direct Drive Linear Motor Options

Two types of linear motors are available, **Ironcore** and **Ironless**. Each one provides characteristics and features that are optimal depending upon the application. Ironcore motors have coils wound on silicon steel laminations, to maximize the generated force, with a single sided magnet way.

Using a patented electromagnetic design, DDL linear motors have the highest rated force per size, a high K_m motor constant (equals low thermal losses), and low cogging forces without the need for skewing of the magnets. The high thrust forces possible with these motors make them ideal for accelerating and moving high masses, and maintaining stiffness during machining or process forces. Ironless motors have no iron, or slots for the coils to be wound on.

Therefore, these motors have zero cogging, a very light mass, and absolutely no attractive forces between the coil assembly and the magnet way. These characteristics are ideal for applications requiring very low bearing friction, high acceleration of lighter loads, and for maximizing constant velocity, even at ultra low speeds. The modular magnet ways consists of a double row of magnets to maximize the generated thrust force and to provide a flux return path for the magnetic circuit.

Feedback Types

All brushless motors require feedback for commutation. The conventional rotary motor typically utilizes a resolver mounted on the rear of the motor or Hall effect devices mounted integrally in the coil windings. For a linear motor, commutation feedback can also be accomplished with a variety of methods. Digital or linear Hall effect devices are available from Kollmorgen for the DDL motor series which allow the drive electronics to commutate the linear motors in a manner identical to rotary motors.

For exceptionally smooth motion requirements, sinusoidal drive electronics such as the Kollmorgen's AKD series, using digital Hall effects, provide sinusoidal drive currents to the motor for the best constant force and velocity performance. As an alternative, it is typical for linear motor applications to have a linear encoder present in the system for position feedback. It is increasingly common today for drive amplifiers, such as the AKD digital amplifier, to derive the necessary commutation information directly from this linear encoder, either with or without supplemental digital Hall effect devices on startup. Other types of feedback used on linear motor applications include linear Inductosyns, laser interferometers, and LVDT.

Advantages

Wide Speed Range

Since the frameless parts of the linear motor are non-contact, and no limitations of a mechanical transmission are present, both very high speeds and very low speeds are easily obtainable. Speeds are truly not limited by the motor. Instead, by eliminating the mechanical transmission, speed becomes limited by other elements in the system such as the linear bearings, and the achievable bandwidth from any feedback devices. Application speeds of greater than 5 meters per second (200 in./sec.) or less than 1 micron per second (.00004 in./sec.) are typically achievable. In comparison, mechanical transmissions such as ball screws are commonly limited to linear speeds of 0.5 to 0.7 meters per second (20-30 in./sec.) because of resonances and wear. In addition to a wide speed range, linear motors, both ironcore and ironless, have excellent constant velocity characteristics, typically better than $\pm 0.01\%$ speed variation.

High System Dynamics

In addition to high speed capability, direct drive linear motors are capable of very high accelerations. Limited only by the system bearings, accelerations of 3 to 5 G are quite typical for the larger motors and accelerations exceeding 10 G are easily achievable for smaller motors.

Easy Selection process:

1. Determine peak and continuous force required for your applications (see our applications section on pages 74-77 or use MOTIONEERING, our online sizing and selection software tool)
2. Use the motor selection guide on pages 15-17 to choose your motor
3. Refer to the appropriate pages in the data publication for technical details
4. Build model number for ordering using pages 78-80

Smooth Operation and Positional Accuracy

Both ironless and ironcore motors exhibit very smooth motion profiles due to the inherent motor design of Kollmorgen's DDL series. Cogging, which is a component of force, is greatly reduced in the ironcore designs and is zero in the ironless designs. As a result, these direct drive linear motors provide very low force and velocity ripple for ultra smooth motion. Positioning accuracies are limited only by the feedback resolution, and sub-micron resolutions are commonly achievable.

Unlimited Travel

With the DDL motor series, magnet ways are made in 5 modular sections: 64 mm, 128 mm, 256 mm, 512 mm and 1024 mm long. Each module can be added in unlimited numbers to any other module to allow for unlimited travel. Whether the travel required is 1mm (0.04 inches) or 100 meters (330 feet), the DDL series can accommodate the need.

No Wear or Maintenance

Linear motors have few components, therefore the need for ball screw components such as nuts, bearing blocks, couplings, motor mounts and the need to maintain these components have been eliminated. Very long life and clean operation, with no lubrication or maintenance of these parts are the result.

Integration of Components is Much Simpler

Frameless linear motors require much fewer components than rotary motors with mechanical transmissions. A 0.8 mm airgap (0.031 inches) for the ironcore design and 0.5 mm airgap (0.020 inches) for the ironless design is the only alignment of the frameless linear motor components that is necessary. No critical alignments are required as with ball screws. Straightness of travel as provided by the system linear bearings is more than sufficient for the Kollmorgen linear motors.

Typical Applications for Linear Motors Include:

Machine Tool	Measurement/inspection
Drilling	Coordinate measurement machines
Milling	Electronic assembly
Grinding	Pick-and-place machines
Laser cutting	Component insertion
Cam grinding	Screen printers
Semiconductor	Adhesive dispensers
Wafer handling process	PC board inspection, drilling
Wafer-inspection	
Wafer slicing	Other applications include:
Tab bonding	Flight Simulators
Wire bonding	Acceleration sleds
Ion implantation	Catapult
Lithography	G-Force measurement
Textile	
Carpet tufting	

AKD™ Servo Drive

Our AKD series is a complete range of Ethernet-based servo drives that are fast, feature-rich, flexible and integrate quickly and easily into any application. AKD ensures plug-and-play commissioning for instant, seamless access to everything in your machine. And, no matter what your application demands, AKD offers industry-leading servo performance, communication options, and power levels, all in a smaller footprint.

This robust, technologically advanced family of drives delivers optimized performance when paired with our best-in-class components, producing higher quality results at greater speeds and more uptime. With Kollmorgen servo components, we can help you increase your machine's OEE by 50%.

The Benefits of AKD Servo Drive

- Optimized Performance in Seconds
 - Auto-tuning is one of the best and fastest in the industry
 - Automatically adjusts all gains, including observers
 - Immediate and adaptive response to dynamic loads
 - Precise control of all motor types
 - Compensation for stiff and compliant transmission and couplings
- Greater Throughput and Accuracy
 - Up to 27-bit-resolution feedback yields unmatched precision and excellent repeatability
 - Very fast settling times result from a powerful dual processor system that executes industry-leading and patent pending servo algorithms with high resolution
 - Advanced servo techniques such as high-order observer and bi-quad filters yield industry-leading machine performance
 - Highest bandwidth torque-and-velocity loops. Fastest digital current loop in the market
- Easy-to-use Graphical User Interface (GUI) for Faster Commissioning and Troubleshooting
 - Six-channel real-time software oscilloscope commissions and diagnoses quickly
 - Multi-function Bode Plot allows users to quickly evaluate performance
 - Auto-complete of programmable commands saves looking up parameter names
 - One-click capture and sharing of program plots and parameter settings allow you to send machine performance data instantly
 - Widest range of programming options in the industry
- Flexible and Scalable to Meet any Application
 - 3 to 24 Arms continuous current; 9 to 48 Arms peak
 - Very high power density enables an extremely small package
 - True plug-and-play with all standard Kollmorgen servomotors and actuators
 - Supports a variety of single and multi-turn feedback devices—Smart Feedback Device (SFD), EnDat2.2, 01, BiSS, analog Sine/Cos encoder, incremental encoder, HIPERFACE®, and resolver
 - Tightly integrated Ethernet motion buses without the need to add large hardware: EtherCAT®, SynqNet®, Modbus/TCP, EtherNet/IP, PROFINET, and CANopen®
 - Scalable programmability from base torque-and-velocity through multi-axis master

AKD Servo Drive

The AKD servo drive delivers cutting-edge technology and performance with one of the most compact footprints in the industry. These feature-rich drives provide a solution for nearly any application, from basic torque-and-velocity applications, to indexing, to multi-axis programmable motion with embedded Kollmorgen Automation Suite. The versatile AKD sets the standard for power density and performance.



Micron™ Gearheads



AKM™ Servomotors



Kollmorgen Cartridge DDR™ Motors



Housed Direct Drive Rotary Motors



Direct Drive Linear Motors*



Linear Actuators



Multi-Axis Precision Tables

Best-in-Class Components

AKD works seamlessly with Kollmorgen motors and actuators—well-known for quality, reliability, and performance.



AKD™ Servo Drive



Industry-leading power density

General Specifications

120 / 240 Vac 1 & 3 Phase (85 -265 V)	Continuous Current (Arms)	Peak Current (Arms)	Drive Continuous Output Power Capacity (Watts)	Internal Regen		Height mm (in)	Width mm (in)	Depth mm (in)	Depth with Cable Bend Radius mm (in)
				(Watts)	(Ohms)				
AKD-■00306	3	9	1100	0	0	168 (6.61)	57 (2.24)	153 (6.02)	184 (7.24)
AKD-■00606	6	18	2000	0	0	168 (6.61)	57 (2.24)	153 (6.02)	184 (7.24)
AKD-■01206	12	30	4000	100	15	195 (7.68)	76 (2.99)	186 (7.32)	215 (8.46)
AKD-■02406	24	48	8000	200	8	250 (9.84)	100 (3.94)	230 (9.06)	265 (10.43)
240/480 Vac 3 Phase (187-528 V)	Continuous Current (Arms)	Peak Current (Arms)	Drive Continuous Output Power Capacity (Watts)	Internal Regen		Height mm (in)	Width mm (in)	Depth mm (in)	Depth with Cable Bend Radius mm (in)
				(Watts)	(Ohms)				
AKD-■00307	3	9	2000	100	33	256 (10.08)	70 (2.76)	186 (7.32)	221 (8.70)
AKD-■00607	6	18	4000	100	33	256 (10.08)	70 (2.76)	186 (7.32)	221 (8.70)
AKD-■01207	12	30	8000	100	33	256 (10.08)	70 (2.76)	186 (7.32)	221 (8.70)
AKD-■02407	24	48	16,000	200	23	310 (12.20)	105 (4.13)	229 (9.02)	264 (10.39)
S748	48	96	35,000	—	—	385 (15.16)	190 (7.48)	244 (9.61)	285 (11.22)
S772	72	140	50,000	—	—	385 (15.16)	190 (7.48)	244 (9.61)	285 (11.22)

Note: For complete AKD and S700 model nomenclature, refer to page 80.

Co-Engineering Capabilities

Because Kollmorgen offers the highest quality and broadest range of best-in-class motion components, we can supply standard, modified or customized solutions to meet any application need.

We have co-engineer solutions to meet your most difficult challenges and advance your competitive position. Drawing on a wealth of knowledge and expertise, our engineering support team will work alongside with you to build a solution that differentiates your machine and improves your bottom line.

Here are just few examples of how Kollmorgen delivers real value to companies likes yours:

What You Need	Why Motion Matters	Kollmorgen Co-Engineering Results
30% Increase in Throughput	<ul style="list-style-type: none"> • Low inertia servomotors • High bandwidth servo loops • Simple, accurate, graphical programming tools 	Using the Kollmorgen Automation Suite™ graphical camming design tool, Pipe Network™ and low-inertia AKM servomotors, a major supplier of medical equipment increased throughput by more than 30% while improving accuracy and reducing scrap.
50% Increase in Accuracy and Quality	<ul style="list-style-type: none"> • Low cogging servomotors • Advaced observers and bi-quad filters • Fast control loop update rates (.67µs) 	Using our AKD servo drive, a next-generation CT scanning manufacturer achieved more than 50% improvement in velocity ripple to produce the most accurate and detailed medical images possible while overcoming an extremely high moment of inertia.
25% Increase in Reliability (Overall Equipment Effectiveness)	<ul style="list-style-type: none"> • Innovative Cartridge Direct Drive Rotary™ DDR motor • Eliminating parts on the machine • No additional wearing components 	Using Kollmorgen’s award-winning Cartridge DDR sevomotor technology, we eliminated more than 60 parts in a die-cutting machine and increased the OEE by 25% and throughput by 20%.
50% Reduction in Waste	<ul style="list-style-type: none"> • Superior motor/drive system bandwidth • DDR technology: <ul style="list-style-type: none"> – eliminates gearbox – 20X more accurate than geared solution 	We helped a manufacturer of pharmaceutical packaging machines incorporate Housed DDR motors to increase the throughput by 35% and reduce scrap by more than 50% through more accurate alignment of the capsules.

Direct Drive Linear Motor Summary

Ironless Linear Motors

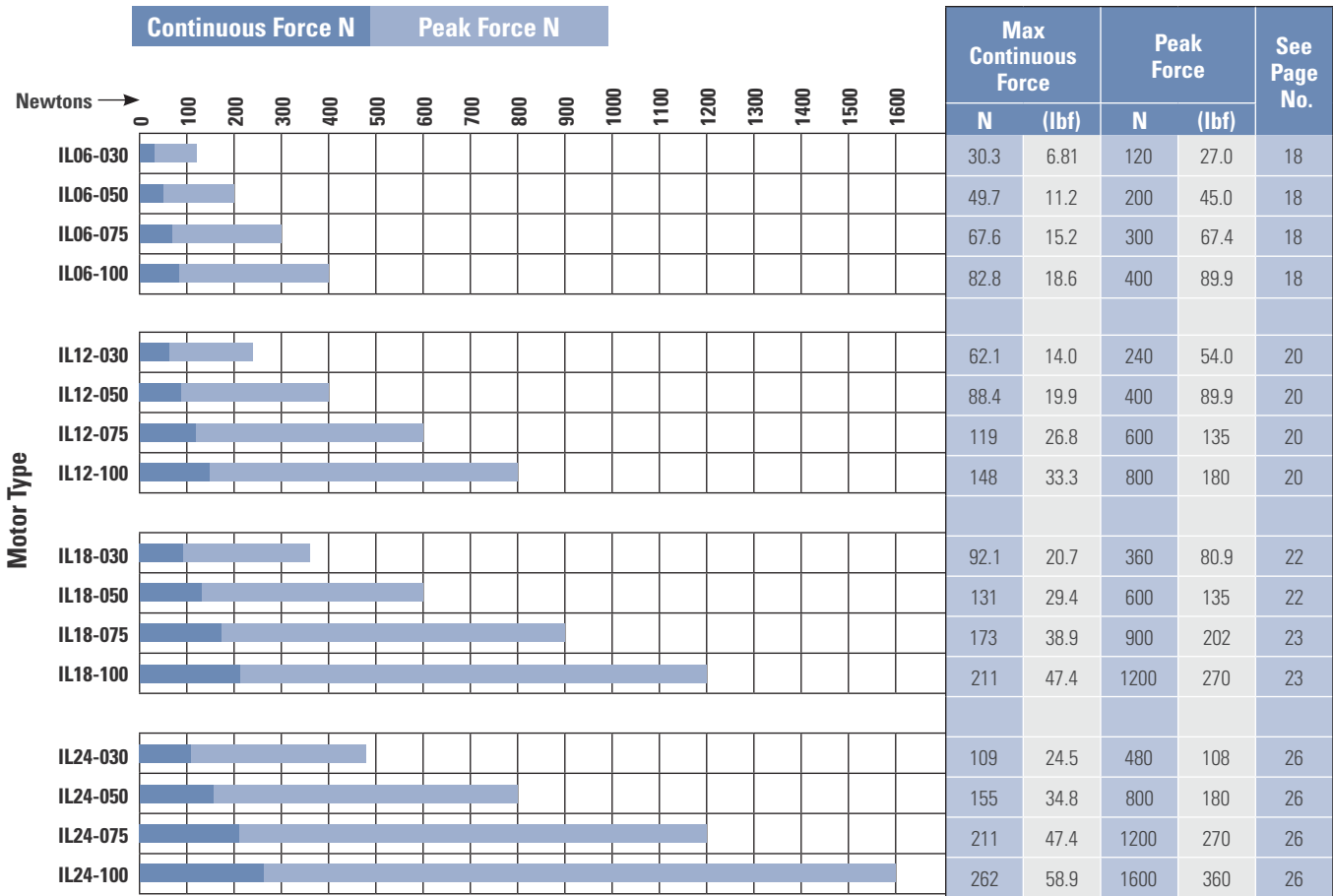

ICD Linear Motors

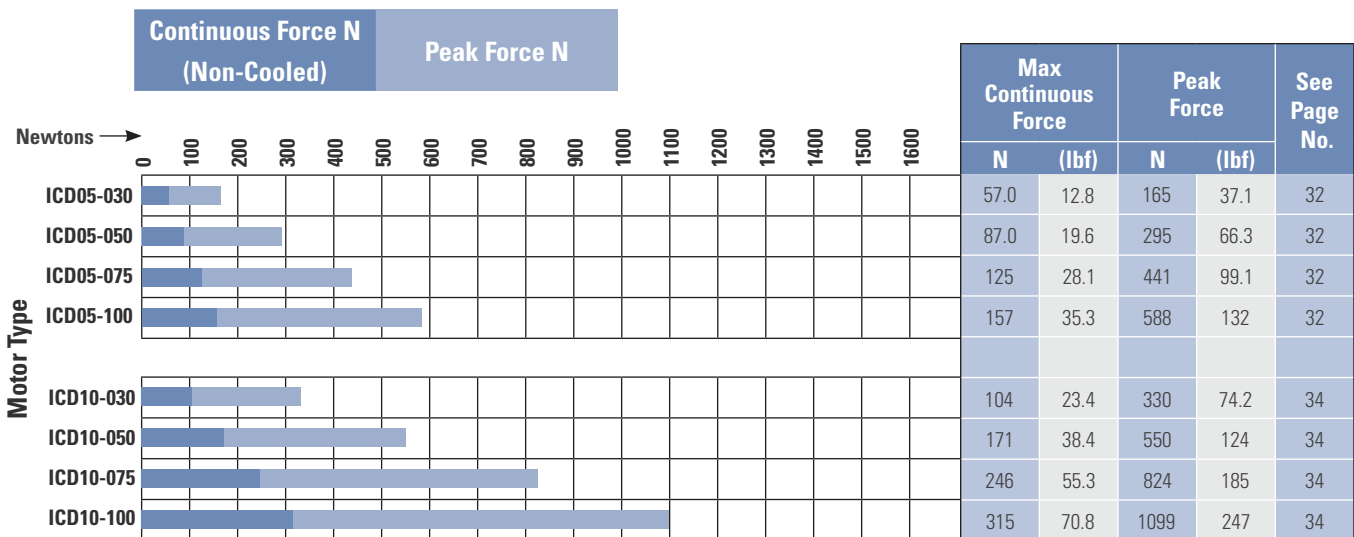

Note: Performance data summarized here represents motor data only. For system performance data with Kollmorgen drives use the Motioneering Application Engine sizing software. See page 81 for more information about Motioneering.

Direct Drive Linear Motor Summary

Ironcore Linear Motors

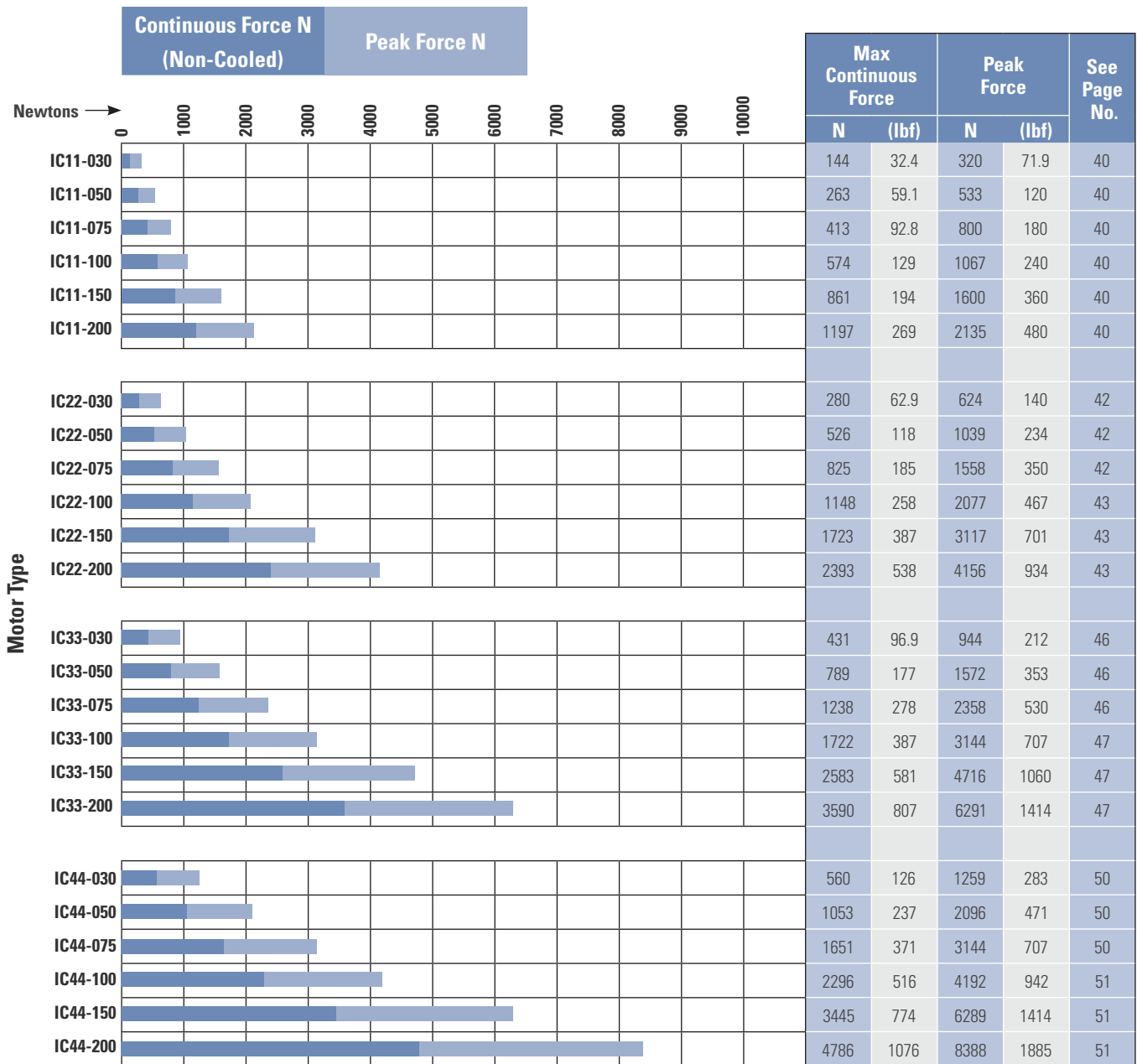

Note: Performance data summarized here represents motor data only. For system performance data with Kollmorgen drives use the Motioneering Application Engine sizing software. See page 81 for more information about Motioneering.

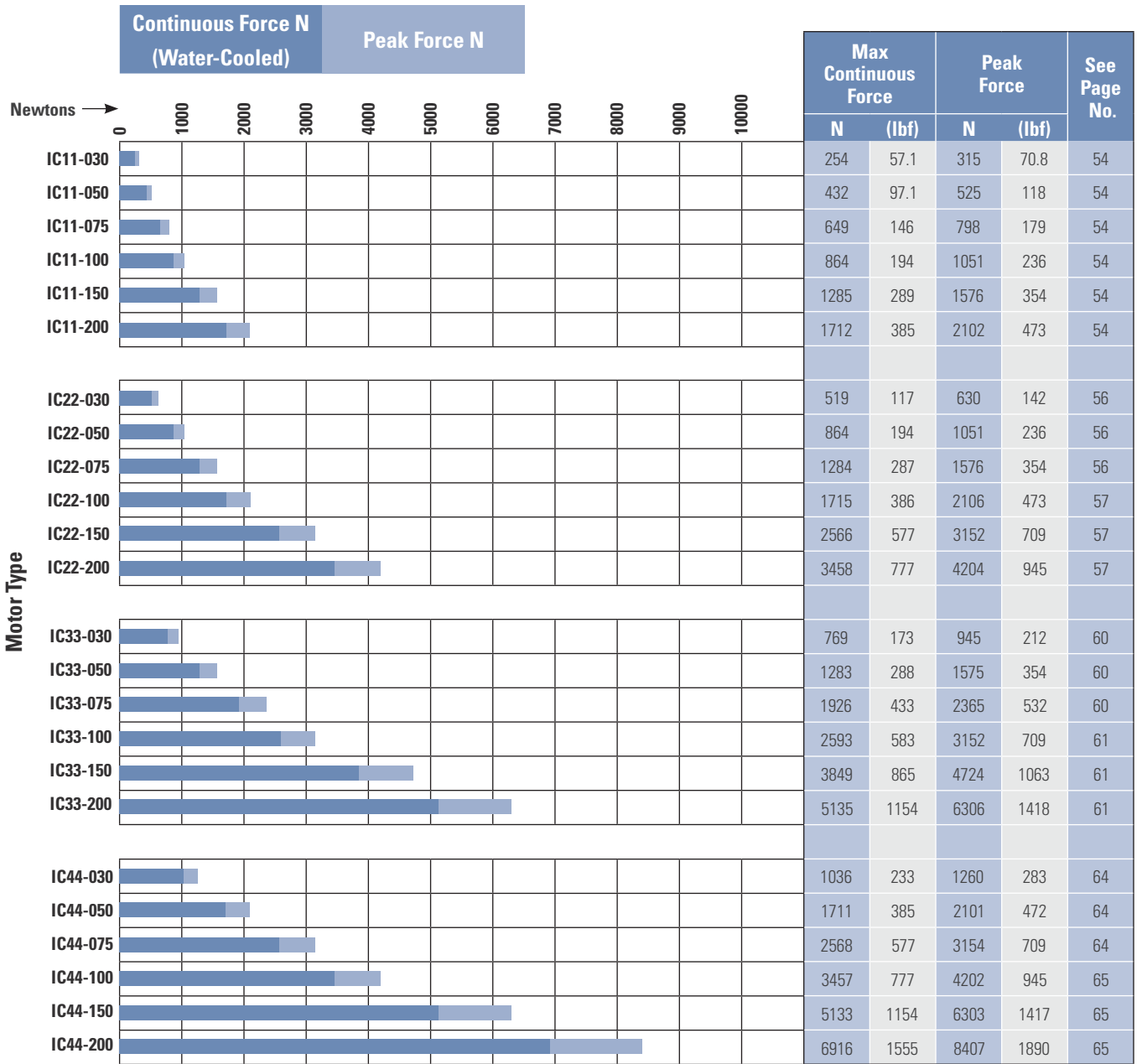

Note: Performance data summarized here represents motor data only. For system performance data with Kollmorgen drives use the Motioneering Application Engine sizing software. See page 81 for more information about Motioneering.

IL06 Performance Data

Ironless Non-Cooled Motors Series

Rated Performance	Symbol	Units	IL06-030	IL06-050	IL06-075	IL06-100				
Peak Force	Fp	N	120	200	300	400				
		lbf	27	45	68	90				
Continuous Force @ Tmax (1)	Fc	N	30.3	49.7	67.6	82.8				
		lbf	6.81	11.2	15.2	18.6				
Motor Constant	Km	N/√W	5.6	8.0	10.2	12.1				
Electrical Specifications (2)										
		Winding Code	A1	A4	A1	A4	A1	A4	A1	A4
Peak Current	Ip	Arms	7.1	14.2	7.0	14.0	7.0	14.0	7.0	14.0
Continuous Current @Tmax	Ic	Arms	1.8	3.6	1.7	3.5	1.6	3.2	1.5	2.9
Electrical Resistance @ 25°C±10%	Rm	Ohms L-L	6.1	1.5	8.6	2.2	11.7	2.9	14.7	3.7
Electrical Inductance ±20%	L	mH L-L	1.3	0.33	3.00	0.75	5.00	1.25	7.00	1.75
Back EMF Constant @ 25°C±10%	Ke	Vpeak/m/s L-L	13.7	6.9	23.3	11.6	34.9	17.5	46.5	23.3
		Vpeak/in/sec L-L	0.35	0.17	0.59	0.30	0.89	0.44	1.18	0.59
Force Constant @ 25°C±10%	kf	N/Arms	16.8	8.4	28.5	14.3	42.8	21.4	57.0	28.5
		lbf/Arms	3.8	1.9	6.4	3.2	9.6	4.8	12.8	6.4
Mechanical Specifications										
Coil Assembly Weight ±15%	Mc	kg	0.27		0.32		0.38		0.45	
		lbs	0.6		0.7		0.8		1.0	
Magnetic Way Type			MW		MW		MW075		MW075	
			030	030L	050	050L				
Magnetic Way Weight ±15%	Mw	kg/m	9.4	7.3	12.2	10.2	18.9		27.3	
		lb/in	0.51	.040	0.68	0.56	1.05		1.51	
Figures of Merit and Additional Data										
Electrical Time Constant	Te	ms	0.21		0.35		0.43		0.48	
Max.Theoretical Acceleration (3)	Amax	g's	45.2		63.6		80.6		90.7	
Magnetic Attraction	Fa	kN	0		0		0		0	
		lbf	0		0		0		0	
Thermal Resistance (4) (Coils to External Structure)	Rth	°C/Watt	1.61		1.26		1.04		0.87	
Max. Allowable Coil Temp. (4)	Tmax	°C	130		130		130		130	

Notes:

1. The motor continuous rated force is measured with the motor coils achieving the motor maximum allowable temperature Tmax.
2. Alternate windings can be made available. Please consult the Kollmorgen Customer Support for design options.
3. Maximum theoretical acceleration is based on the motors peak force and the motor mass alone. Limitations due to such factors as the additional mass of the load, the bearing type and design, the shock rating of the feedback, the peak current available from the amplifier etc. must be considered to determine the achievable acceleration in each application.
4. Please see our application sizing pages in the back of this guide for more details on sizing and thermal considerations.

IL06 Outline Drawings

Ironless Non-Cooled Motors Series

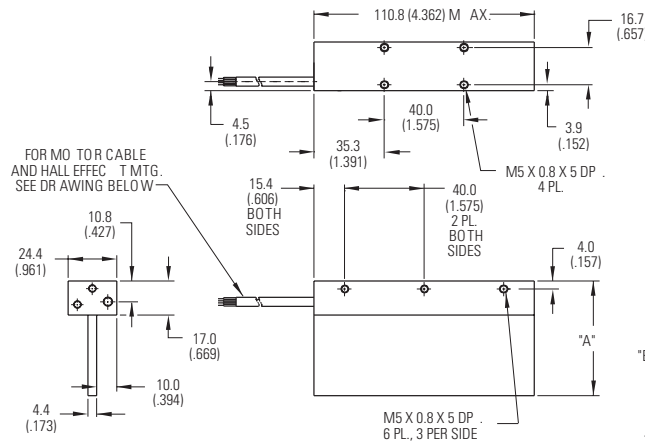

Motor Coil	Coil Width		Typ. Assy. Width	Typ. Assy. Width
	"A"	+7 (0.027) -3 (0.012)	"B" ±.6 (.024)	"T" ±.4 (.016)
IL06-030	57.30 (2.256)		78.50 (3.091)	25.40 (1.000)
IL06-030 L	57.30 (2.256)		67.30 (2.650)	25.40 (1.000)
IL06-050	77.30 (3.043)		98.50 (3.878)	25.40 (1.000)
IL06-050 L	77.30 (3.043)		87.30 (3.437)	25.40 (1.000)
IL06-075	102.30 (4.028)		123.50 (4.862)	30.00 (1.181)
IL06-100	127.30 (5.012)		148.50 (5.846)	34.00 (1.339)

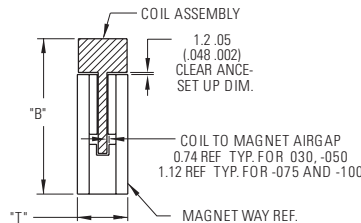

Notes:

1. Dimensions in mm (inches)
2. Tolerances unless otherwise specified:
no decimal place ±0.8 (0.3)
X decimal place ±0.1 (.004)
XX decimal place ±0.05 (0.002)

Termination and Hall Effect Options

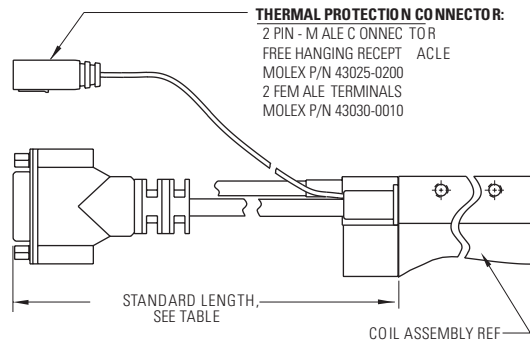
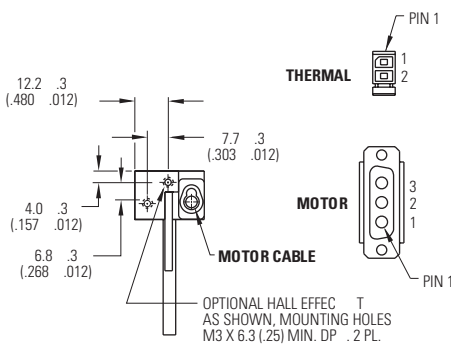

MATING CONNECTOR REFERENCE:
MOLEX® MICRO-FIT 3.0®
PLUG: 43020-0201
MALE TERMINALS: 43031-0010
SEE WIRE TABLE, PAGE 70

HALL EFFECT CONNECTOR OPTION:
POSITRONIC P/N: MD9M2000Z
9 PIN, M ALE
MATING CONNECTOR REFERENCE:
POSITRONIC P/N: MD9F2000X
SEE WIRE TABLE, PAGE 70

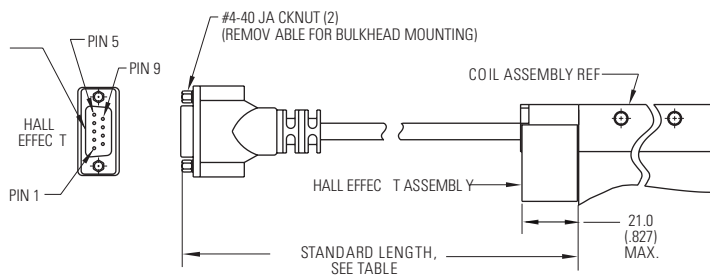

MATING CONNECTOR REFERENCE:
POSITRONIC P/N: CBD3W3F0000X
3 FEM ALE SOCKETS, SOLDER TYPE,
SIZE 8, POSITRONIC P/N: FS40-D
SEE WIRE TABLE, PAGE 70

HALL EFFECT MA
W/P CONNecTOR: .05KG (.11 LB) MAX
W/C CABLE: .03KG (.06 LB) M AX

Connector Option	
Connector	Length
P1	400 (16)
P2	200 (8)
P3	100 (4)
P4	1200 (48)

Flying Lead Option	
Leads	Length
C1	400 (16)
C2	200 (8)
C3	100 (4)
C4	1200 (48)

Note:
Cables exiting motor and hall effects are not dynamic flex cables. For high life flex extension cables, see page 72

IL12 Performance Data

Ironless Non-Cooled Motors Series

Rated Performance	Symbol	Units	IL12-030			IL12-050			IL12-075			IL12-100	
Peak Force	Fp	N	240			400			600			800	
		lbf	54			90			135			180	
Continuous Force @ Tmax (1)	Fc	N	62.1			88.4			119			148	
		lbf	14.0			19.9			26.8			33.3	
Motor Constant @ 25°C	Km	N√W	7.8			11.3			14.5			17.2	
Electrical Specifications (2)													
		Winding Code	A1	A2	A4	A1	A2	A4	A1	A2	A4	A2	A4
Peak Current	Ip	Arms	7.1	14.2	28.5	7.0	14.0	28.1	7.0	14.0	28.1	14.0	28.1
Continuous Current @Tmax	Ic	Arms	1.8	3.7	7.4	1.6	3.1	6.2	1.4	2.8	5.6	2.6	5.2
Electrical Resistance @ 25°C±10%	Rm	Ohms L-L	12.2	3.1	0.8	17.2	4.3	1.1	23.3	5.8	1.5	7.4	1.8
Electrical Inductance ±20%	L	mH L-L	2.60	0.65	0.16	6.00	1.5	0.38	10.0	2.5	0.63	3.5	0.88
Back EMF Constant @ 25°C±10%	Ke	Vpeak/m/s L-L	27.5	13.8	6.9	46.5	23.3	11.6	69.8	34.9	17.5	46.5	23.3
		Vpeak/in/sec L-L	0.70	0.35	0.17	1.18	0.59	0.30	1.77	0.89	0.44	1.18	0.59
Force Constant @ 25°C±10%	Kf	N/Arms	33.7	16.9	8.4	57.0	28.5	14.3	85.5	42.8	21.4	57.0	28.5
		lbf/Arms	7.6	3.8	1.9	12.8	6.4	3.2	19.2	9.6	4.8	12.8	6.4
Mechanical Specifications													
Coil Assembly Weight ±15%	Mc	kg	0.42			0.52			0.65			0.77	
		lbs	0.9			1.1			1.4			1.7	
Magnetic Way Type			MW			MW			MW075			MW100	
			030	030L	050	050L							
Magnetic Way Weight ±15%	Mw	kg/m	9.4	7.3	12.2	10.2	18.9			27.3			
		lb/in	0.51	0.40	0.68	0.56	1.05			1.51			
Figures of Merit and Additional Data													
Electrical Time Constant	Te	ms	0.21			0.35			0.43			0.48	
Max.Theoretical Acceleration (3)	Amax	g's	58.2			78.4			94.1			106	
Magnetic Attraction	Fa	kN	0			0			0			0	
		lbf	0			0			0			0	
Thermal Resistance (4) (coils to external structure)	Rth	°C/Watt	0.804			0.629			0.519			0.433	
Max. Allowable Coil Temp. (4)	Tmax	°C	130			130			130			130	

Notes:

1. The motor continuous rated force is measured with the motor coils achieving the motor maximum allowable temperature Tmax.
2. Alternate windings can be made available. Please consult the Kollmorgen Customer Support for design options.
3. Maximum theoretical acceleration is based on the motors peak force and the motor mass alone. Limitations due to such factors as the additional mass of the load, the bearing type and design, the shock rating of the feedback, the peak current available from the amplifier etc. must be considered to determine the achievable acceleration in each application.
4. Please see our application sizing pages in the back of this guide for more details on sizing and thermal considerations.

IL18 Performance Data

Ironless Non-Cooled Motors Series

Rated Performance	Symbol	Units	IL18-030				IL18-050			
Peak Force	Fp	N	360				600			
		lbf	81				135			
Continuous Force @ Tmax (1)	Fc	N	92.1				131			
		lbf	20.7				29.4			
Motor Constant @ 25°C	Km	N√W	9.7				13.8			
Electrical Specifications (2)										
		Winding Code	A1	A2	A3	A4	A1	A2	A3	A4
Peak Current	Ip	Arms	7.1	14.3	21.4	42.8	7.0	14.0	21.0	42.1
Continuous Current @Tmax	Ic	Arms	1.8	3.6	5.5	11.0	1.5	3.1	4.6	9.2
Electrical Resistance @ 25°C±10%	Rm	Ohms L-L	18.2	4.6	2.0	0.5	25.7	6.4	2.9	0.7
Electrical Inductance ±20%	L	mH L-L	3.8	0.95	0.42	0.11	9.00	2.25	1.00	0.25
Back EMF Constant @ 25°C±10%	Ke	Vpeak/m/s L-L	41.2	20.6	13.7	6.9	69.8	34.9	23.3	11.6
		Vpeak/in/sec L-L	1.05	0.52	0.35	0.17	1.77	0.89	0.59	0.30
Force Constant @ 25°C±10%	Kf	N/Arms	50.5	25.3	16.8	8.4	85.5	42.8	28.5	14.3
		lbf/Arms	11.4	5.7	3.8	1.9	19.2	9.6	6.4	3.2
Mechanical Specifications										
Coil Assembly Weight ±15%	Mc	kg	0.57				0.72			
		lbs	1.3				1.6			
Magnetic Way Type			MW				MW			
			030	030L	050	050L				
Magnetic Way Weight ±15%	Mw	kg/m	9.4	7.3	12.2	10.2				
		lb/in	0.51	0.40	0.68	0.56				
Figures of Merit and Additional Data										
Electrical Time Constant	Te	ms	0.21				0.35			
Max.Theoretical Acceleration (3)	Amax	g's	64.5				84.9			
Magnetic Attraction	Fa	kN	0				0			
		lbf	0				0			
Thermal Resistance (4) (coils to external structure)	Rth	°C/Watt	0.536				0.419			
Max. Allowable Coil Temp. (4)	Tmax	°C	130				130			

Notes:

1. The motor continuous rated force is measured with the motor coils achieving the motor maximum allowable temperature Tmax.
2. Alternate windings can be made available. Please consult the Kollmorgen Customer Support for design options.
3. Maximum theoretical acceleration is based on the motors peak force and the motor mass alone. Limitations due to such factors as the additional mass of the load, the bearing type and design, the shock rating of the feedback, the peak current available from the amplifier etc. must be considered to determine the achievable acceleration in each application.
4. Please see our application sizing pages in the back of this guide for more details on sizing and thermal considerations.

Rated Performance	Symbol	Units	IL18-075				IL18-100			
Peak Force	Fp	N	900				1200			
		lbf	202				270			
Continuous Force @ Tmax (1)	Fc	N	173				211			
		lbf	38.9				47.4			
Motor Constant @ 25°C	Km	N√W	17.7				21.0			
Electrical Specifications (2)										
		Winding Code	A1	A2	A3	A4	A1	A2	A3	A4
Peak Current	Ip	Arms	7.0	14.0	21.0	42.1	7.0	14.0	21.0	42.1
Continuous Current @Tmax	Ic	Arms	1.4	2.7	4.0	8.1	1.2	2.5	3.7	7.4
Electrical Resistance @ 25°C±10%	Rm	Ohms L-L	35.0	8.8	3.9	1.0	44.2	11.1	4.9	1.2
Electrical Inductance ±20%	L	mH L-L	15.0	3.75	1.67	0.42	21.0	5.25	2.33	0.58
Back EMF Constant @ 25°C±10%	Ke	Vpeak/m/s L-L	105	52.4	34.9	17.5	140	69.9	46.6	23.3
		Vpeak/in/sec L-L	2.66	1.33	0.89	0.44	3.55	1.77	1.18	0.59
Force Constant @ 25°C±10%	Kf	N/Arms	128	64.2	42.8	21.4	171	85.6	57.0	28.5
		lbf/Arms	28.8	14.4	9.6	4.8	38.5	19.2	12.8	6.4
Mechanical Specifications										
Coil Assembly Weight ±15%	Mc	kg	0.91				1.10			
		lbs	2.0				2.4			
Magnetic Way Type			MW075				MW100			
Magnetic Way Weight ±15%	Mw	kg/m	18.9				27.3			
		lb/in	1.05				1.51			
Figures of Merit and Additional Data										
Electrical Time Constant	Te	ms	0.43				0.48			
Max.Theoretical Acceleration (3)	Amax	g's	101				111			
Magnetic Attraction	Fa	kN	0				0			
		lbf	0				0			
Thermal Resistance (4) (coils to external structure)	Rth	°C/Watt	0.35				0.29			
Max. Allowable Coil Temp. (4)	Tmax	°C	130				130			

Notes:

- The motor continuous rated force is measured with the motor coils achieving the motor maximum allowable temperature Tmax.
- Alternate windings can be made available. Please consult the Kollmorgen Customer Support for design options.
- Maximum theoretical acceleration is based on the motors peak force and the motor mass alone. Limitations due to such factors as the additional mass of the load, the bearing type and design, the shock rating of the feedback, the peak current available from the amplifier etc. must be considered to determine the achievable acceleration in each application.
- Please see our application sizing pages in the back of this guide for more details on sizing and thermal considerations.

IL18 Outline Drawings

Ironless Non-Cooled Motors Series

Motor Coil	Coil Width		Typ. Assy. Width	Typ. Assy. Width
	"A"	+7 (0.027) -3 (0.012)	"B" ±.6 (.024)	"T" ±.4 (.016)
IL18-030	57.30 (2.256)		78.50 (3.091)	25.40 (1.000)
IL18-030 L	57.30 (2.256)		67.30 (2.650)	25.40 (1.000)
IL18-050	77.30 (3.043)		98.50 (3.878)	25.40 (1.000)
IL18-050 L	77.30 (3.043)		87.30 (3.437)	25.40 (1.000)
IL18-075	102.30 (4.028)		123.50 (4.862)	30.00 (1.181)
IL18-100	127.30 (5.012)		148.50 (5.846)	34.00 (1.339)

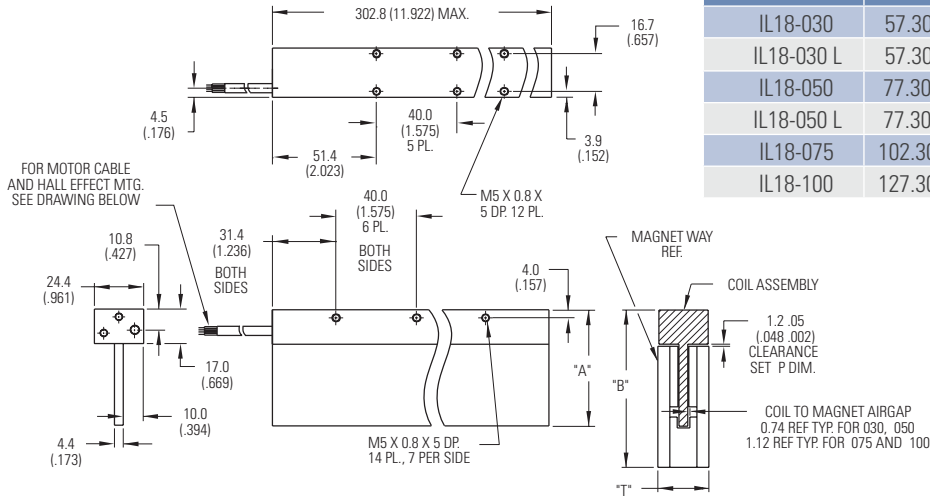

- Notes:
- Dimensions in mm (inches)
 - Tolerances unless otherwise specified:
 - no decimal place ±0.8 (0.3)
 - X decimal place ±0.1 (.004)
 - XX decimal place ±0.05 (0.002)

Termination and Hall Effect Options

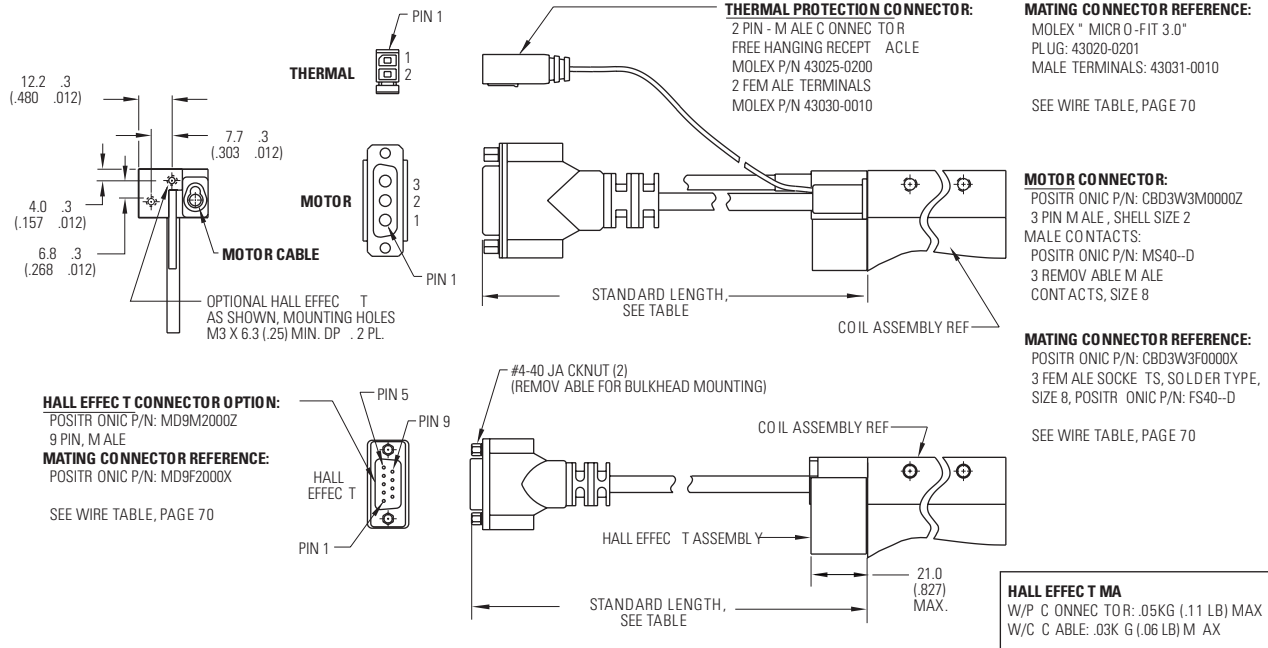

Connector Option	
Connector	Length
P1	400 (16)
P2	200 (8)
P3	100 (4)
P4	1200 (48)

Flying Lead Option	
Leads	Length
C1	400 (16)
C2	200 (8)
C3	100 (4)
C4	1200 (48)

Note:
 Cables exiting motor and hall effects are not dynamic flex cables. For high life flex extension cables, see page 72

Notes

A large grid of graph paper for taking notes, consisting of 20 columns and 30 rows of small squares.

IL24 Performance Data

Ironless Non-Cooled Motors Series

Rated Performance	Symbol	Units	IL24-030			IL24-050			IL24-075				IL24-100			
Peak Force	Fp	N	480			800			1200				1600			
		lbf	108			180			270				360			
Continuous Force @ Tmax (1)	Fc	N	109			155			211				262			
		lbf	24.5			34.8			47.4				58.9			
Motor Constant @ 25°C	Km	N√W	11.2			15.9			20.6				24.4			
Electrical Specifications (2)																
		Winding Code	A1	A2	A3	A1	A2	A3	A1	A2	A3	A4	A1	A2	A3	A4
Peak Current	Ip	Arms	7.1	14.2	28.5	7.0	14.0	28.1	7.0	14.0	28.0	56.1	7.0	14.0	28.1	56.1
Continuous Current @Tmax	Ic	Arms	1.6	3.2	6.4	1.4	2.7	5.4	1.2	2.5	4.9	9.9	1.2	2.3	4.6	9.2
Electrical Resistance @ 25°C±10%	Rm	Ohms L-L	24.3	6.1	1.5	34.3	8.6	2.1	46.6	11.7	2.9	0.73	58.9	14.7	3.7	0.92
Electrical Inductance ±20%	L	mH L-L	5.1	1.28	0.32	12.0	3.00	0.75	20.0	5.0	1.25	0.31	28.0	7.00	1.75	0.44
Back EMF Constant @ 25°C±10%	Ke	Vpeak/m/s L-L	55.0	27.5	13.8	93.1	46.5	23.3	140.	69.9	34.9	17.5	186	93.1	46.6	23.3
		Vpeak/in/sec L-L	1.40	0.70	0.35	2.36	1.18	0.59	3.55	1.77	0.89	0.44	4.73	2.37	1.18	0.59
Force Constant @ 25°C±10%	Kf	N/Arms	67.4	33.7	16.9	114	57.0	28.5	171	85.6	42.8	21.4	228	114	57.0	28.5
		lbf/Arms	15.2	7.6	3.8	25.6	12.8	6.4	38.5	19.2	9.6	4.8	51.3	25.6	12.8	6.4
Mechanical Specifications																
Coil Assembly Weight ±15%	Mc	kg	0.72			0.92			1.17				1.42			
		lbs	1.6			2.0			2.6				3.1			
Magnetic Way Type			MW			MW			MW075				MW100			
			030	030L	050	050L										
Magnetic Way Weight ±15%	Mw	kg/m	9.4	7.3	12.2	10.2							18.9			27.3
		lb/in	0.51	0.40	0.68	0.56							1.05			1.51
Figures of Merit and Additional Data																
Electrical Time Constant	Te	ms	0.21			0.35			0.43				0.48			
Max.Theoretical Acceleration(3)	Amax	g's	68.0			88.7			105				115			
Magnetic Attraction	Fa	kN	0			0			0				0			
		lbf	0			0			0				0			
Thermal Resistance (4) (coils to external structure)	Rth	°C/Watt	0.40			0.32			0.26				0.22			
Max. Allowable Coil Temp. (4)	Tmax	°C	130			130			130				130			

Notes:

1. The motor continuous rated force is measured with the motor coils achieving the motor maximum allowable temperature Tmax.
2. Alternate windings can be made available. Please consult the Kollmorgen Customer Support for design options.
3. Maximum theoretical acceleration is based on the motors peak force and the motor mass alone. Limitations due to such factors as the additional mass of the load, the bearing type and design, the shock rating of the feedback, the peak current available from the amplifier etc. must be considered to determine the achievable acceleration in each application.
4. Please see our application sizing pages in the back of this guide for more details on sizing and thermal considerations.

IL24 Outline Drawings

Ironless Non-Cooled Motors Series

Motor Coil	Coil Width		Typ. Assy. Width	Typ. Assy. Width
	"A"	+7 (0.027) -3 (0.012)	"B" ±6 (.024)	"T" ±4 (.016)
IL24-030	57.30 (2.256)		78.50 (3.091)	25.40 (1.000)
IL24-030 L	57.30 (2.256)		67.30 (2.650)	25.40 (1.000)
IL24-050	77.30 (3.043)		98.50 (3.878)	25.40 (1.000)
IL24-050 L	77.30 (3.043)		87.30 (3.437)	25.40 (1.000)
IL24-075	102.30 (4.028)		123.50 (4.862)	30.00 (1.181)
IL24-100	127.30 (5.012)		148.50 (5.846)	34.00 (1.339)

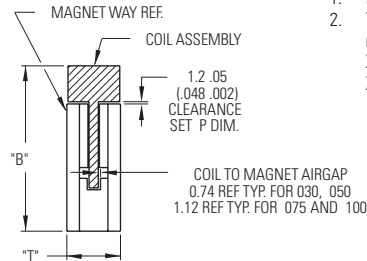
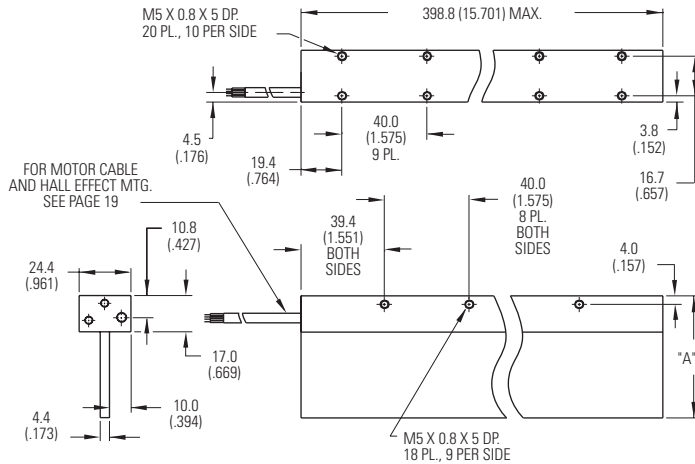

Notes:

1. Dimensions in mm (inches)
2. Tolerances unless otherwise specified:
no decimal place ±0.8 (0.3)
X decimal place ±0.1 (.004)
XX decimal place ±0.05 (0.002)

Termination and Hall Effect Options

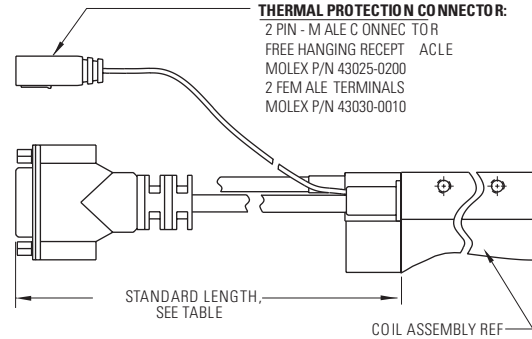
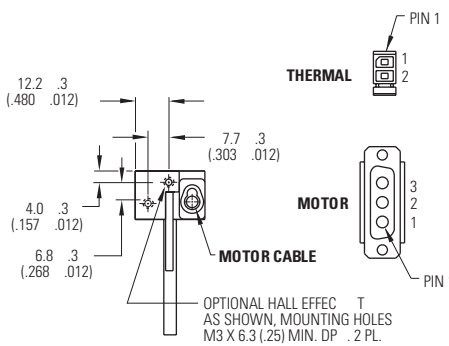

THERMAL PROTECTION CONNECTOR:
2 PIN - M ALE C ONN EC TO R
FREE HANGING RECEPT ACLE
MOLEX P/N 43025-0200
2 FEM ALE TERMINALS
MOLEX P/N 43030-0010

MATING CONNECTOR REFERENCE:
MOLEX " MICR O -FIT 3.0"
PLUG: 43020-0201
MALE TERMINALS: 43031-0010
SEE WIRE TABLE, PAGE 70

MOTOR CONNECTOR:
POSITR ONIC P/N: CBD3W3M0000Z
3 PIN M ALE, SHELL SIZE 2
MALE CONTACTS:
POSITR ONIC P/N: MS40--D
3 REMOV ABLE M ALE
CON TACTS, SIZE 8

MATING CONNECTOR REFERENCE:
POSITR ONIC P/N: CBD3W3F0000X
3 FEM ALE SOCKE TS, SOLDER TYPE,
SIZE 8, POSITR ONIC P/N: FS40--D
SEE WIRE TABLE, PAGE 70

HALL EFFEC T CONNECTOR OPTION:
POSITR ONIC P/N: MD9M2000Z
9 PIN, M ALE
MATING CONNECTOR REFERENCE:
POSITR ONIC P/N: MD9F2000X
SEE WIRE TABLE, PAGE 70

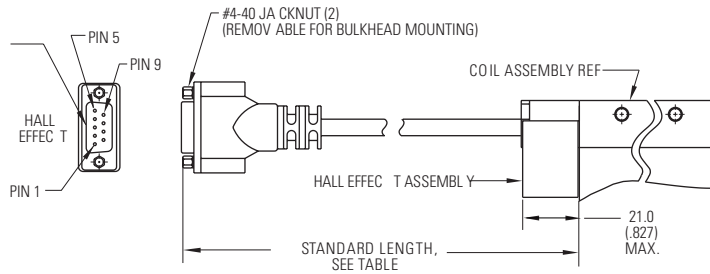

HALL EFFEC T MA
W/P C ONN EC TO R: .05KG (.11 LB) MAX
W/C C ABL E: .03K G (.06 LB) M AX

Lead	Length
P1	400 (16)
P2	200 (8)
P3	100 (4)
P4	1200 (48)

Flying Lead Option	
Leads	Length
C1	400 (16)
C2	200 (8)
C3	100 (4)
C4	1200 (48)

Note:
Cables exiting motor and hall effects are not dynamic flex cables. For high life flex extension cables, see page 72

Ironless Magnet Ways

MWxxx-0064

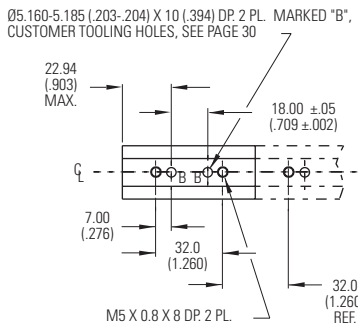
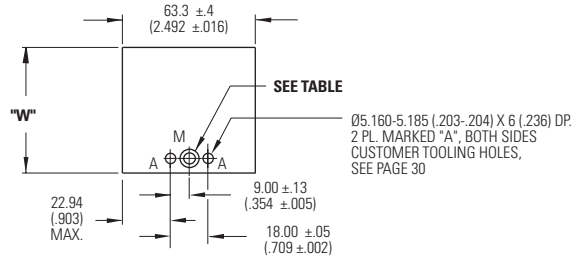

Magnet assemblies are modular and can be installed in multiples of same or alternate lengths (see page 30). Standard assembly lengths are shown below.

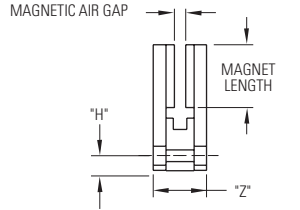

- Notes:
1. Dimensions in mm (inches)
 2. Tolerances unless otherwise specified:
no decimal place ± 0.8 (0.3)
X decimal place ± 0.1 (.004)
XX decimal place ± 0.05 (0.002)

Magnet Way	Magnet Size Ref.	"H" ± 0.8 (.003)	"W" ± 0.4 (.016)	"Z" ± 0.4 (.016)
MW030-0064	30mm	7.11 (.280)	60.20 (2.370)	25.40 (1.000)
MW030L-0064	30mm	5.69 (.224)	49.00 (1.929)	25.40 (1.000)
MW050-0064	50mm	7.11 (.280)	80.20 (3.158)	25.40 (1.000)
MW050L-0064	50mm	5.69 (.224)	69.00 (2.716)	25.40 (1.000)
MW075-0064	75mm	8.23 (.324)	105.20 (4.142)	30.00 (1.181)
MW100-0064	100mm	8.23 (.324)	130.20 (5.126)	34.00 (1.339)

Magnet Way	Hardware (Hex, Socket Head Cap)					
	Hole Dia. ± 0.13 (.005)	C'bore Dia. ± 0.13 (.005)	Cbore Depth ± 0.13 (.005)	Metric	Inch	Bottom Mount Thread Option
MW030-0064	5.70 (.224)	9.35 (.368)	5.79 (.228)	M5	#10	M5 X 0.8 X 8.0 DP.
MW030L-0064	4.70 (.185)	7.80 (.307)	5.79 (.228)	M4	#8	M4 X 0.7 X 6.0 DP.
MW050-0064	5.70 (.224)	9.35 (.368)	5.79 (.228)	M5	#10	M5 X 0.8 X 8.0 DP.
MW050L-0064	4.70 (.185)	7.80 (.307)	5.79 (.228)	M4	#8	M4 X 0.7 X 6.0 DP.
MW075-0064	5.70 (.224)	9.35 (.368)	7.95 (.313)	M5	#10	M5 X 0.8 X 8.0 DP.
MW100-0064	5.70 (.224)	9.35 (.368)	9.96 (.392)	M5	#10	M5 X 0.8 X 8.0 DP.

MWxxx-0128

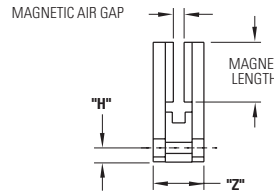
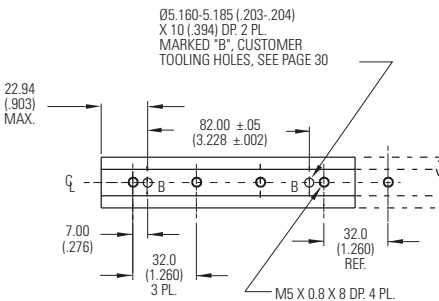
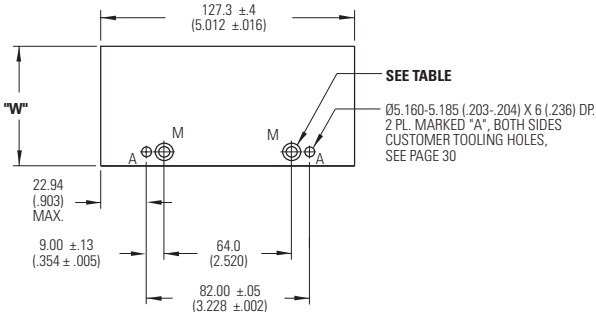

Magnet Way	Magnet Size Ref.	"H" ± 0.8 (.003)	"W" ± 0.4 (.016)	"Z" ± 0.4 (.016)
MW030-0128	30mm	7.11 (.280)	60.20 (2.370)	25.40 (1.000)
MW030L-0128	30mm	5.69 (.224)	49.00 (1.929)	25.40 (1.000)
MW050-0128	50mm	7.11 (.280)	80.20 (3.158)	25.40 (1.000)
MW050L-0128	50mm	5.69 (.224)	69.00 (2.716)	25.40 (1.000)
MW075-0128	75mm	8.23 (.324)	105.20 (4.142)	30.00 (1.181)
MW100-0128	100mm	8.23 (.324)	130.20 (5.126)	34.00 (1.339)

Magnet Way	Hardware (Hex, Socket Head Cap)					
	Hole Dia. ± 0.13 (.005)	C'bore Dia. ± 0.13 (.005)	Cbore Depth ± 0.13 (.005)	Metric	Inch	Bottom Mount Thread Option
MW030-0128	5.70 (.224)	9.35 (.368)	5.79 (.228)	M5	#10	M5 X 0.8 X 8.0 DP.
MW030L-0128	4.70 (.185)	7.80 (.307)	5.79 (.228)	M4	#8	M4 X 0.7 X 6.0 DP.
MW050-0128	5.70 (.224)	9.35 (.368)	5.79 (.228)	M5	#10	M5 X 0.8 X 8.0 DP.
MW050L-0128	4.70 (.185)	7.80 (.307)	5.79 (.228)	M4	#8	M4 X 0.7 X 6.0 DP.
MW075-0128	5.70 (.224)	9.35 (.368)	7.95 (.313)	M5	#10	M5 X 0.8 X 8.0 DP.
MW100-0128	5.70 (.224)	9.35 (.368)	9.96 (.392)	M5	#10	M5 X 0.8 X 8.0 DP.

MWxxx-0256

Magnet assemblies are modular and can be installed in multiples of same or alternate lengths (see page 30). Standard assembly lengths are shown below.

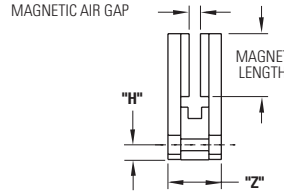
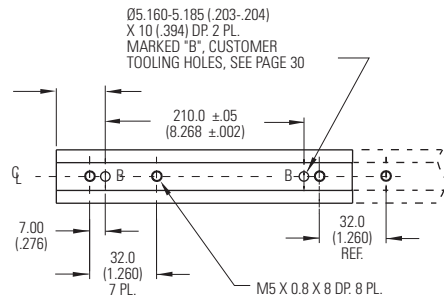
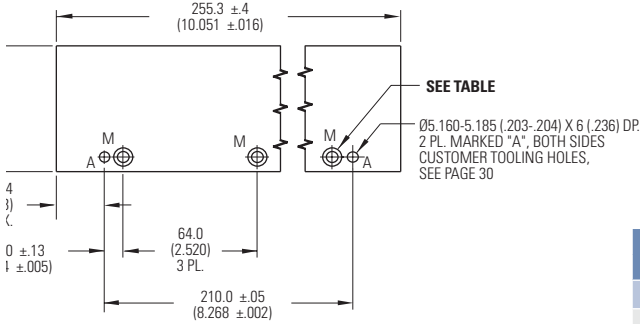

Notes:

1. Dimensions in mm (inches)
2. Tolerances unless otherwise specified:
no decimal place ±0.8 (0.3)
X decimal place ±0.1 (.004)
XX decimal place ±0.05 (0.002)

Magnet Way	Magnet Size Ref.	"H" ±.8 (.003)	"W" ±.4 (.016)	"Z" ±.4 (.016)
MW030-0256	30mm	7.11 (.280)	60.20 (2.370)	25.40 (1.000)
MW030L-0256	30mm	5.69 (.224)	49.00 (1.929)	25.40 (1.000)
MW050-0256	50mm	7.11 (.280)	80.20 (3.158)	25.40 (1.000)
MW050L-0256	50mm	5.69 (.224)	69.00 (2.716)	25.40 (1.000)
MW075-0256	75mm	8.23 (.324)	105.20 (4.142)	30.00 (1.181)
MW100-0256	100mm	8.23 (.324)	130.20 (5.126)	34.00 (1.339)

Magnet Way	Hardware (Hex, Socket Head Cap)					
	Hole Dia. ±.13 (.005)	C'bore Dia. ±.13 (.005)	Cbore Depth ±.13 (.005)	Metric	Inch	Bottom Mount Thread Option
MW030-0512	5.70 (.224)	9.35 (.368)	5.79 (.228)	M5	#10	M5 X 0.8 X 8.0 DP.
MW030L-0512	4.70 (.185)	7.80 (.307)	5.79 (.228)	M4	#8	M4 X 0.7 X 6.0 DP.
MW050-0512	5.70 (.224)	9.35 (.368)	5.79 (.228)	M5	#10	M5 X 0.8 X 8.0 DP.
MW050L-0512	4.70 (.185)	7.80 (.307)	5.79 (.228)	M4	#8	M4 X 0.7 X 6.0 DP.
MW075-0512	5.70 (.224)	9.35 (.368)	7.95 (.313)	M5	#10	M5 X 0.8 X 8.0 DP.
MW100-0512	5.70 (.224)	9.35 (.368)	9.96 (.392)	M5	#10	M5 X 0.8 X 8.0 DP.

MWxxx-0512

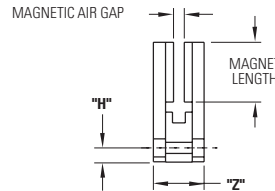
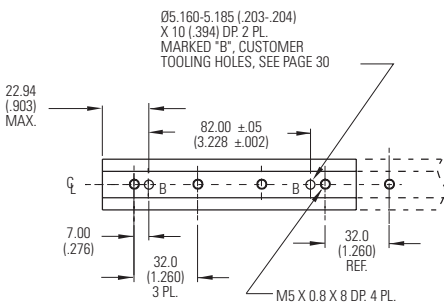
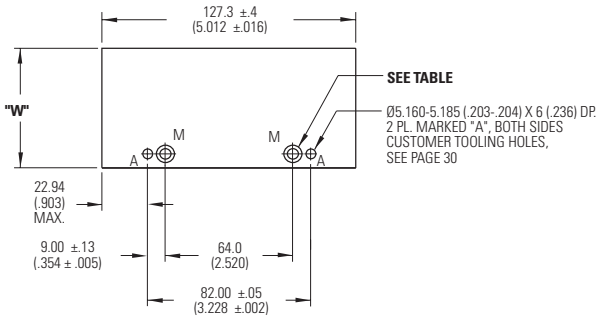

Magnet Way	Magnet Size Ref.	"H" ±.8 (.003)	"W" ±.4 (.016)	"Z" ±.4 (.016)
MW030-0512	30mm	7.11 (.280)	60.20 (2.370)	25.40 (1.000)
MW030L-0512	30mm	5.69 (.224)	49.00 (1.929)	25.40 (1.000)
MW050-0512	50mm	7.11 (.280)	80.20 (3.158)	25.40 (1.000)
MW050L-0512	50mm	5.69 (.224)	69.00 (2.716)	25.40 (1.000)
MW075-0512	75mm	8.23 (.324)	105.20 (4.142)	30.00 (1.181)
MW100-0512	100mm	8.23 (.324)	130.20 (5.126)	34.00 (1.339)

Magnet Way	Hardware (Hex, Socket Head Cap)					
	Hole Dia. ±.13 (.005)	C'bore Dia. ±.13 (.005)	Cbore Depth ±.13 (.005)	Metric	Inch	Bottom Mount Thread Option
MW030-0512	5.70 (.224)	9.35 (.368)	5.79 (.228)	M5	#10	M5 X 0.8 X 8.0 DP.
MW030L-0512	4.70 (.185)	7.80 (.307)	5.79 (.228)	M4	#8	M4 X 0.7 X 6.0 DP.
MW050-0512	5.70 (.224)	9.35 (.368)	5.79 (.228)	M5	#10	M5 X 0.8 X 8.0 DP.
MW050L-0512	4.70 (.185)	7.80 (.307)	5.79 (.228)	M4	#8	M4 X 0.7 X 6.0 DP.
MW075-0512	5.70 (.224)	9.35 (.368)	7.95 (.313)	M5	#10	M5 X 0.8 X 8.0 DP.
MW100-0512	5.70 (.224)	9.35 (.368)	9.96 (.392)	M5	#10	M5 X 0.8 X 8.0 DP.

Ironless Magnet Ways

Magnet Way widths correspond to the mating coil assembly width.
Magnet Way assemblies are modular and come in standard lengths: 64, 128, 256, 512 mm.

Bottom Mounting Installation

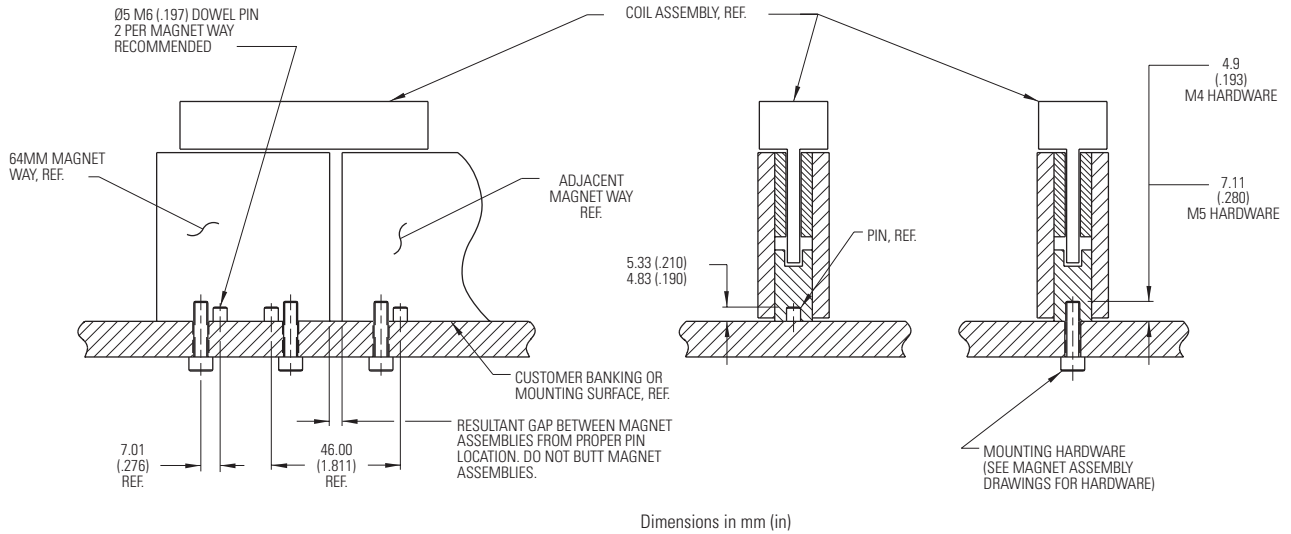

Side mounting installation

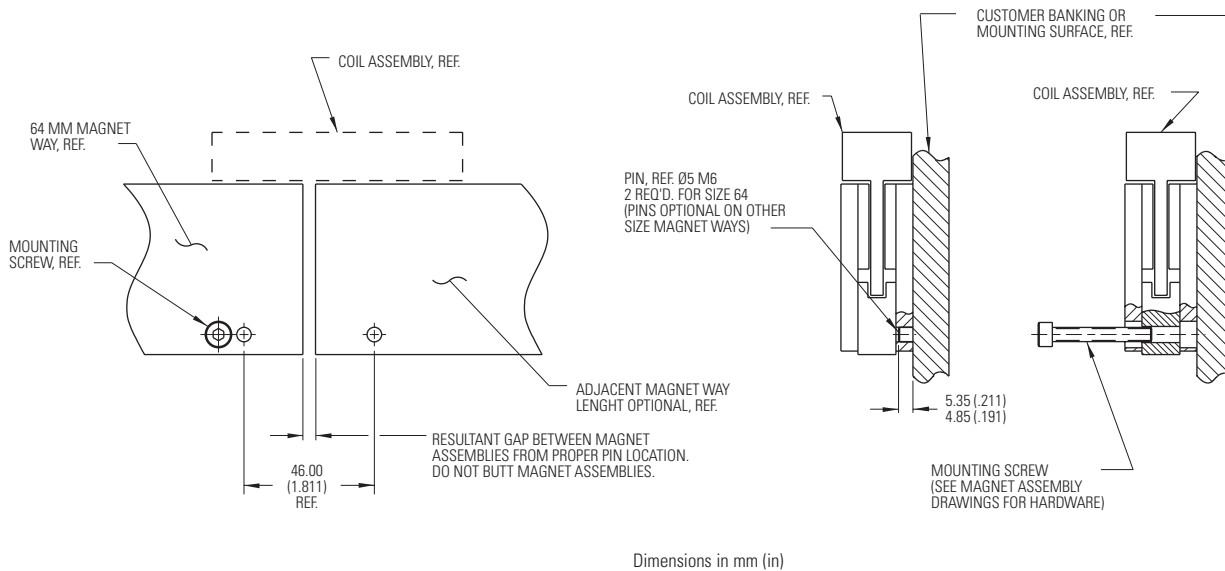

Notes

A large grid of graph paper for taking notes, consisting of 20 columns and 30 rows of small squares.

ICD05 Performance Data

Ironcore Motors Series

Rated Performance	Symbol	Units	ICD05-030	ICD05-050	ICD05-075	ICD05-100				
Peak Force	Fp	N	165	295	441	588				
		lbf	37.1	66.3	99.1	132				
Continuous Force @ Tmax (1)	Fc	N	57.0	87.0	125	157				
		lbf	12.8	19.6	28.1	35.3				
Motor Constant @ 130°C	Km	N/√W	10.3	14.5	18.6	22.0				
		lbf/√W	2.3	3.3	4.2	4.9				
Motor Constant @ 25°C	Km25	N/√W	12.3	17.2	22.0	26.0				
		lbf/√W	2.8	3.9	4.9	5.9				
Electrical Specifications (2)										
		Winding Code	A1	A5	A1	A5	A1	A5	A1	A5
Peak Current	Ip	Arms	7.9	13.7	8.5	14.7	8.5	14.7	8.5	14.7
Continuous Current @Tmax	Ic	Arms	2.1	3.7	2.0	3.4	1.9	3.3	1.8	3.1
Electrical Resistance @ 25°C±10%	Rm	Ohms L-L	3.2	1.1	4.5	1.5	6.1	2.0	7.7	2.6
Electrical Inductance ±20%	L	mh L-L	9.1	3.0	14.4	4.8	21.0	7.0	27.6	9.2
Back EMF Constant @25°C±10%	Ke	Vpeak/m/s L-L	21.8	12.6	36.3	21.0	54.3	31.4	72.4	41.8
		Vpeak/in/sec L-L	0.55	0.32	0.92	0.53	1.38	0.80	1.84	1.06
Force Constant @ 25°C±10%	Kf	N/Arms	26.7	15.4	44.5	25.7	66.5	38.4	88.7	51.2
		lbf/Arms	6.0	3.5	10.0	5.8	15.0	8.6	19.9	11.5
Mechanical Specifications										
Coil Assembly Weight ±15%	Mc	kg	0.62	0.95	1.36	1.71				
		lbs	1.4	2.1	3.0	3.8				
Magnetic Way Type			MCD030	MCD050	MCD075	MCD100				
Magnetic Way Weight ±15%	Mw	kg/m	2.70	3.93	5.48	7.04				
		lbs/in	0.15	0.22	0.31	0.39				
Figures of Merit and Additional Data										
Electrical Time Constant	Te	ms	2.9	3.2	3.4	3.6				
Max.Theoretical Acceleration (3)	Amax	g's	28.0	30.2	31.9	32.8				
Magnetic Attraction	Fa	kN	0.53	0.89	1.33	1.78				
		lbf	119	200	299	400				
Thermal Resistance (4) (coils to external structure)	Rth	°C/Watt	3.50	2.90	2.30	2.06				
Max. Allowable Coil Temp. (4)	Tmax	°C	130	130	130	130				

Notes:

1. The motor continuous rated force is measured with the motor coils achieving the motor maximum allowable temperature Tmax.
2. Alternate windings can be made available. Please consult the Kollmorgen Customer Support for design options.
3. Maximum theoretical acceleration is based on the motors peak force and the motor mass alone. Limitations due to such factors as the additional mass of the load, the bearing type and design, the shock rating of the feedback, the peak current available from the amplifier etc. must be considered to determine the achievable acceleration in each application.
4. Please see our application sizing pages in the back of this guide for more details on sizing and thermal considerations.

ICD05 Outline Drawings

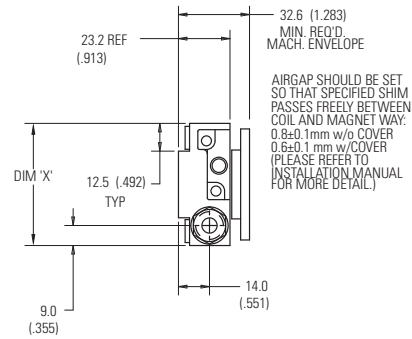
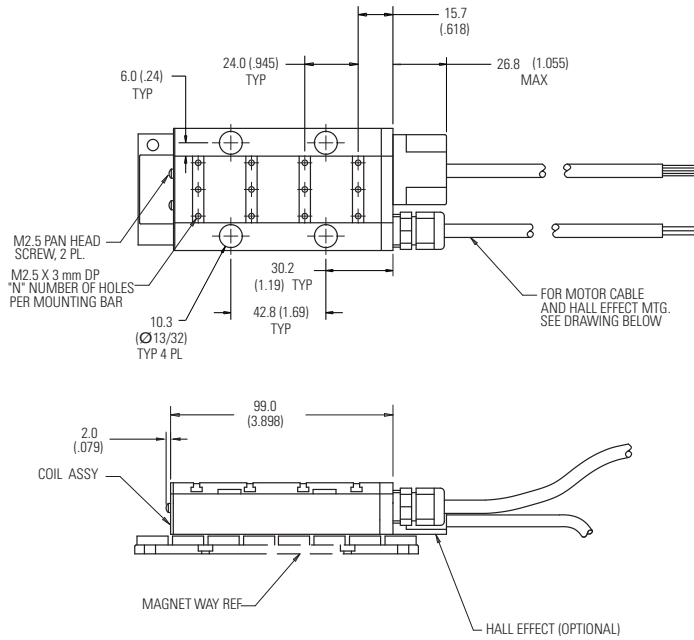

Motor Coil Type	Coil Width	# Holes
	"X"	"N"
ICD05-030	55.0 (2.165) ± 1.0 (.04)	3
ICD05-050	75.0 (2.953) ± 1.0 (.04)	4
ICD05-075	100.0 (3.937) ± 1.0 (.04)	5
ICD05-100	125.0 (4.921) ± 1.0 (.04)	5

- Notes:
- Dimensions in mm (inches)
 - Tolerances unless otherwise specified:
 - no decimal place ±0.8 (0.3)
 - X decimal place ±0.1 (.004)
 - XX decimal place ±0.05 (0.002)

Termination and Hall Effect Options

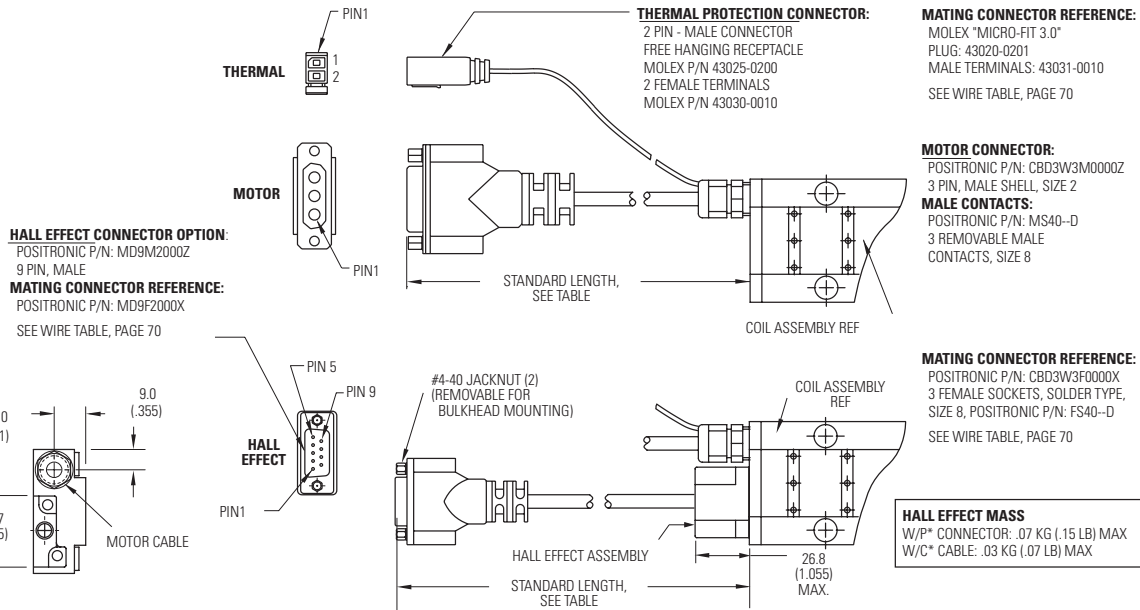

Connector Option	
Connector	Length
P1	400 (16)
P2	200 (8)
P3	100 (4)
P4	1200 (48)

Flying Lead Option	
Leads	Length
C1	400 (16)
C2	200 (8)
C3	100 (4)
C4	1200 (48)

Note:
Cables exiting motor and hall effects are not dynamic flex cables. For high life flex extension cables, see page 72

HALL EFFECT MASS
W/P* CONNECTOR: .07 KG (.15 LB) MAX
W/C* CABLE: .03 KG (.07 LB) MAX

ICD10 Performance Data

Ironcore Motors Series

Rated Performance	Symbol	Units	ICD10-030				ICD10-050				ICD10-075				ICD10-100			
Peak Force	Fp	N	330				550				824				1099			
		lbf	74.2				124				185				247			
Continuous Force @ Tmax (1)	Fc	N	104				171				246				315			
		lbf	23.4				38.4				55.3				70.8			
Motor Constant @ 130°C	Km	N/√W	14.6				20.5				26.4				31.3			
		lbf/√W	3.3				4.6				5.9				7.0			
Motor Constant @ 25°C	Km25	N/√W	17.3				24.3				31.3				37.1			
		lbf/√W	3.9				5.5				7.0				8.3			
Electrical Specifications (2)																		
		Winding Code	A1	A4	A5	A8	A1	A4	A5	A8	A1	A4	A5	A8	A1	A4	A5	A8
Peak Current	Ip	Arms	7.9	15.8	13.7	27.4	7.9	15.8	13.7	27.4	7.9	15.8	13.7	27.4	7.9	15.8	13.7	27.4
Continuous Current @Tmax	Ic	Arms	1.9	3.9	3.4	6.8	1.9	3.8	3.3	6.6	1.8	3.7	3.2	6.4	1.8	3.5	3.1	6.1
Electrical Resistance @ 25°C±10%	Rm	Ohms L-L	6.4	1.6	2.1	0.5	9.0	2.2	3.0	0.7	12.2	3.0	4.1	1.0	15.4	3.9	5.1	1.3
Electrical Inductance ±20%	L	mh L-L	18.3	4.6	6.1	1.5	29.0	7.3	9.7	2.4	42.4	10.6	14.1	3.5	55.8	13.9	18.6	4.6
Back EMF Constant @25°C±10%	Ke	Vpeak/m/s L-L	43.7	21.8	25.2	12.6	72.8	36.4	42.0	21.0	109.2	54.6	63.1	31.5	145.7	72.8	84.1	42.0
		Vpeak/in/sec L-L	1.11	0.55	0.64	0.32	1.85	0.92	1.07	0.53	2.77	1.39	1.60	0.80	3.70	1.85	2.14	1.07
Force Constant @ 25°C±10%	Kf	N/Arms	53.5	26.8	30.9	15.4	89.2	44.6	51.5	25.7	134	66.9	77.2	38.6	178	89.2	103	51.5
		lbf/Arms	12.0	6.0	6.9	3.5	20.1	10.0	11.6	5.8	30.1	15.0	17.4	8.7	40.1	20.1	23.2	11.6
Mechanical Specifications																		
Coil Assembly Weight ±15%	Mc	kg	1.1				1.9				2.7				3.4			
		lbs	2.5				4.1				5.9				7.5			
Magnetic Way Type			MCD030				MCD050				MCD075				MCD100			
Magnetic Way Weight ±15%	Mw	kg/m	2.70				3.93				5.48				7.04			
		lbs/in	0.15				0.22				0.31				0.39			
Figures of Merit and Additional Data																		
Electrical Time Constant	Te	ms	2.9				3.2				3.5				3.6			
Max.Theoretical Acceleration(3)	Amax	g's	30.7				30.7				32.5				33.7			
Magnetic Attraction	Fa	kN	1.06				1.78				2.66				3.56			
		lbf	2.38				400				598				800			
Thermal Resistance (4) (coils to external structure)	Rth	°C/Watt	2.05				1.52				1.21				1.04			
Max. Allowable Coil Temp. (4)	Tmax	°C	130				130				130				130			

Notes:

- The motor continuous rated force is measured with the motor coils achieving the motor maximum allowable temperature Tmax.
- Alternate windings can be made available. Please consult the Kollmorgen Customer Support for design options.
- Maximum theoretical acceleration is based on the motors peak force and the motor mass alone. Limitations due to such factors as the additional mass of the load, the bearing type and design, the shock rating of the feedback, the peak current available from the amplifier etc. must be considered to determine the achievable acceleration in each application.
- Please see our application sizing pages in the back of this guide for more details on sizing and thermal considerations.

ICD10 Outline Drawings

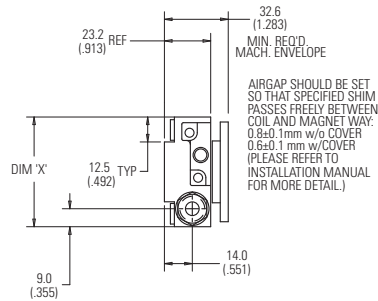
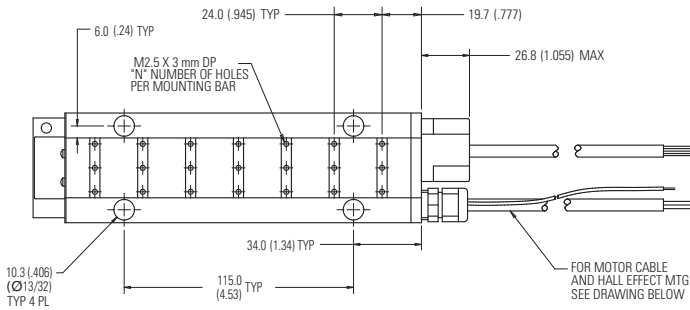

Motor Coil Type	Coil Width "X"	# Holes "N"
	ICD10-030	55.0 (2.165) ± 1.0 (.04)
ICD10-050	75.0 (2.953) ± 1.0 (.04)	4
ICD10-075	100.0 (3.937) ± 1.0 (.04)	5
ICD10-100	125.0 (4.921) ± 1.0 (.04)	5

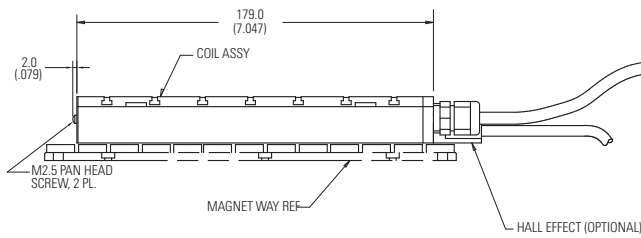

Notes:

1. Dimensions in mm (inches)
2. Tolerances unless otherwise specified:
no decimal place ±0.8 (0.3)
X decimal place ±0.1 (.004)
XX decimal place ±0.05 (0.002)

Termination and Hall Effect Options

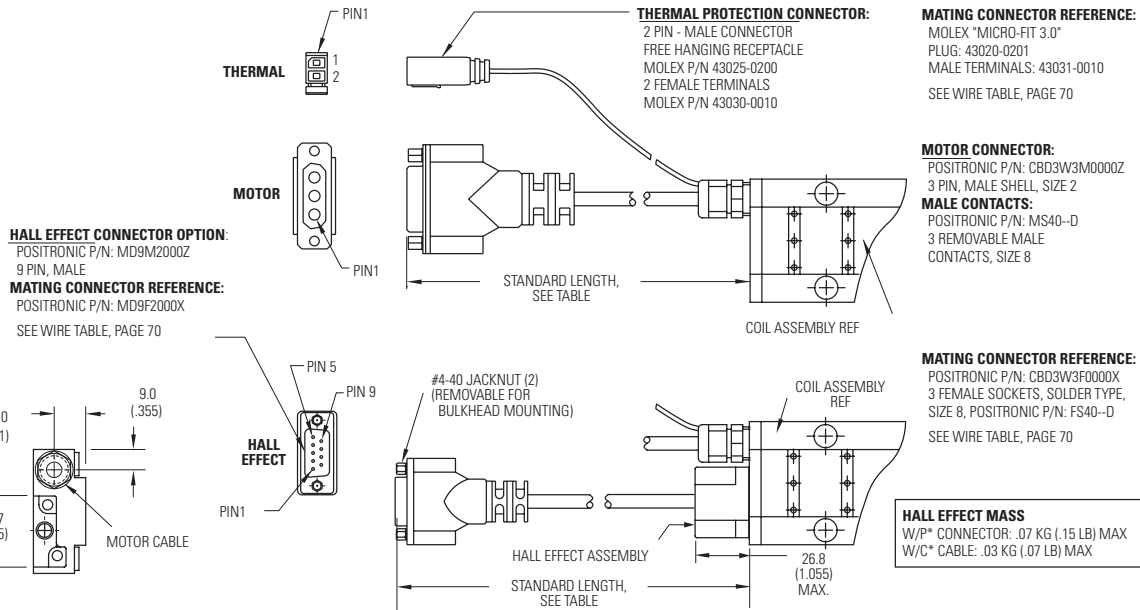

Connector Option	
Connector	Length
P1	400 (16)
P2	200 (8)
P3	100 (4)
P4	1200 (48)

Flying Lead Option	
Leads	Length
C1	400 (16)
C2	200 (8)
C3	100 (4)
C4	1200 (48)

Note:
Cables exiting motor and hall effects are not dynamic flex cables. For high life flex extension cables, see page 72

ICD Magnet Ways

MCDxx-0064

Magnet assemblies are modular and can be installed in multiples of same or alternate lengths (see page 38). Standard assembly lengths are shown below.

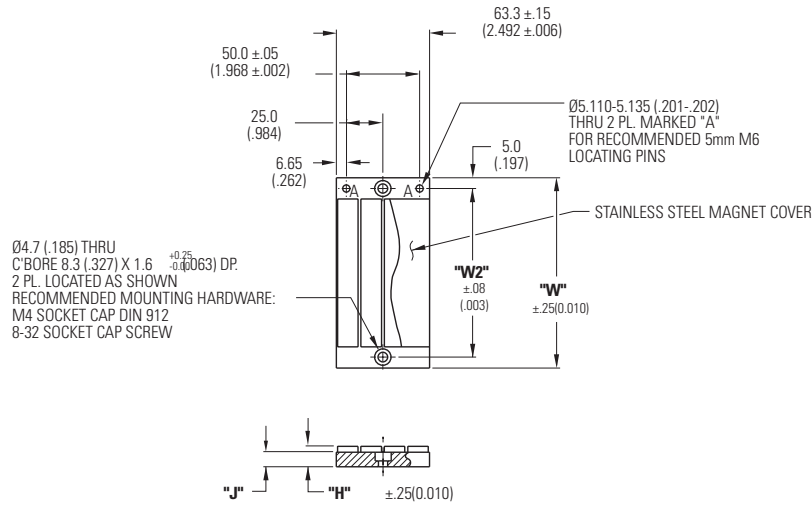

Type	"W"	"W2"	"J"	"H"
MCD030-0064-001	55.0 (2.165)	45.0 (1.772)	4.0 (.157)	8.25 (.325)
MCD050-0064-001	75.0 (2.953)	65.0 (2.559)	4.0 (.157)	8.25 (.325)
MCD075-0064-001	100.0 (3.937)	90.0 (3.543)	4.0 (.157)	8.25 (.325)
MCD100-0064-001	125.0 (4.921)	115.0 (4.528)	4.0 (.157)	8.25 (.325)

Dimensions in mm (in)

MCDxx-0128

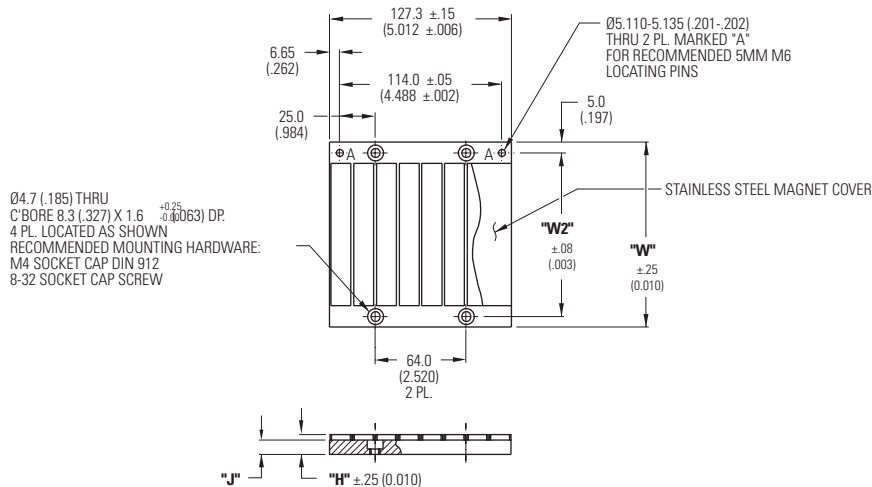

Type	"W"	"W2"	"J"	"H"
MCD030-0128-001	55.0 (2.165)	45.0 (1.772)	4.0 (.157)	8.25 (.325)
MCD050-0128-001	75.0 (2.953)	65.0 (2.559)	4.0 (.157)	8.25 (.325)
MCD075-0128-001	100.0 (3.937)	90.0 (3.543)	4.0 (.157)	8.25 (.325)
MCD100-0128-001	125.0 (4.921)	115.0 (4.528)	4.0 (.157)	8.25 (.325)

Dimensions in mm (in)

MCDxx-0256

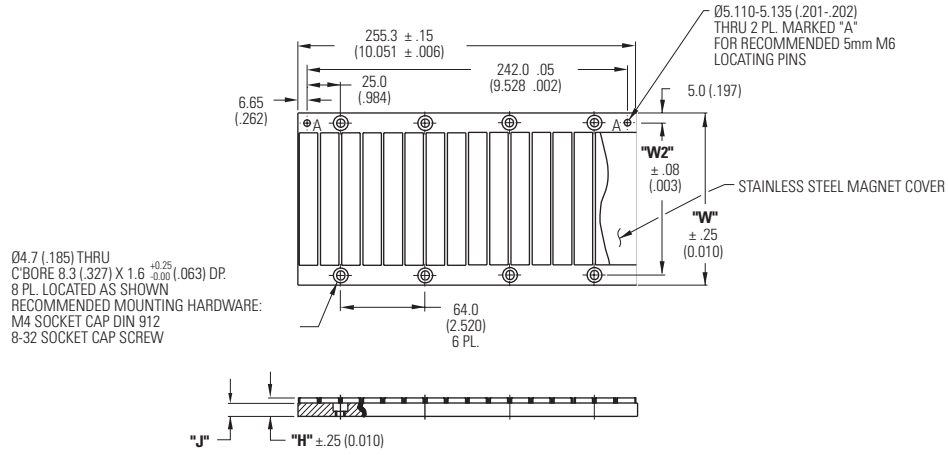

Type	"W"	"W2"	"J"	"H"	Dimensions in mm (in)
MCD030-0256-001	55.0 (2.165)	45.0 (1.772)	4.0 (.157)	8.25 (.325)	
MCD050-0256-001	75.0 (2.953)	65.0 (2.559)	4.0 (.157)	8.25 (.325)	
MCD075-0256-001	100.0 (3.937)	90.0 (3.543)	4.0 (.157)	8.25 (.325)	
MCD100-0256-001	125.0 (4.921)	115.0 (4.528)	4.0 (.157)	8.25 (.325)	

MCDxx-0512

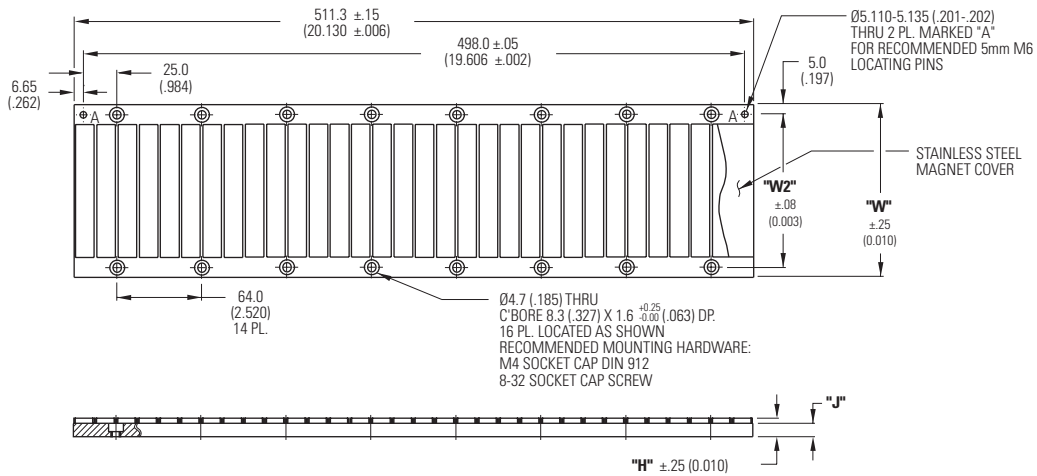

Type	"W"	"W2"	"J"	"H"	Dimensions in mm (in)
MCD030-0512-001	55.0 (2.165)	45.0 (1.772)	4.0 (.157)	8.25 (.325)	
MCD050-0512-001	75.0 (2.953)	65.0 (2.559)	4.0 (.157)	8.25 (.325)	
MCD075-0512-001	100.0 (3.937)	90.0 (3.543)	4.0 (.157)	8.25 (.325)	
MCD100-0512-001	125.0 (4.921)	115.0 (4.528)	4.0 (.157)	8.25 (.325)	

ICD Magnet Ways

Typical Installation of Multiple Ironcore Magnet Assemblies

Magnet Way widths correspond to the mating coil assembly width. Magnet Way assemblies are modular and come in standard lengths: 64, 128, 256, 512 mm. Multiple magnet assemblies can be installed to obtain the desired length.

Shown below is the method to mount multiple assemblies.

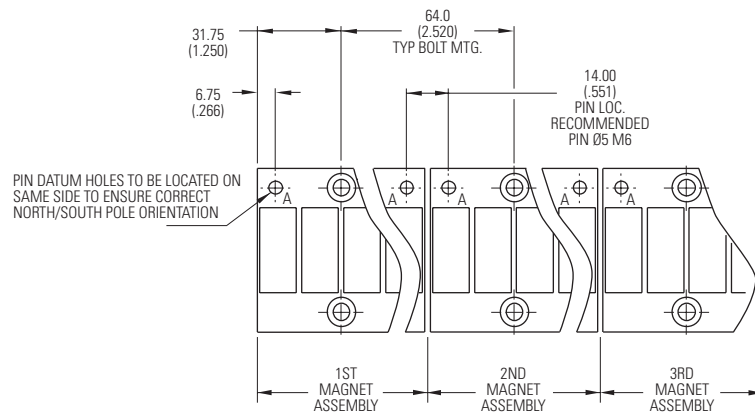

Dimensions in mm (in)

Typical Mounting Bar Lengths & Mounting Holes Tabulation

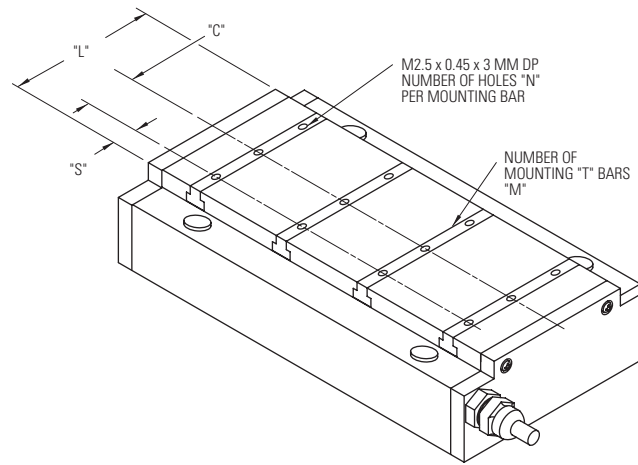

Dimensions in mm (in)

Motor Coil Type	Number of Holes "N"	Spacing Between Holes "C"	Mounting Bar Length "L"	"S"	Motor Coil Type	Number of Bars "M"
ICDXX-030	3	12.0 (.472)	30 (1.18)	3.0 (.118)	ICD05-XXX	4
ICDXX-050	4	12.0 (.472)	50 (1.97)	7.0 (2.76)	ICD10-XXX	7
ICDXX-075	5	16.0 (.630)	75 (2.95)	5.5 (.217)		
ICDXX-100	5	20.0 (.787)	100 (3.94)	10.0 (.394)		

Notes

A large grid of graph paper for taking notes, consisting of 20 columns and 30 rows of small squares.

IC11 Performance Data

Ironcore Non-Cooled Motors Series

Rated Performance	Symbol	Units	IC11-030	IC11-050	IC11-075	IC11-100	IC11-150	IC11-200						
Peak Force	Fp	N	320	533	800	1067	1600	2135						
		lbf	71.9	120	180	240	360	480						
Continuous Force @ Tmax (1)	Fc	N	144	263	413	574	861	1197						
		lbf	32.4	59.1	92.8	129	194	269						
Motor Constant @ 25°C	Km	N/√W	22.5	32.0	41.4	49.1	62.0	73.0						
Electrical Specifications (2)														
		Winding Code	A1	A5	A1	A5	A1	A5	A1	A5	A1	A5	A1	A5
Peak Current	Ip	Arms	11.3	19.1	11.3	19.1	11.3	19.1	11.3	19.1	11.3	19.1	11.3	19.1
Continuous Current @Tmax	Ic	Arms	4.0	6.9	4.4	7.6	4.6	8.0	4.8	8.2	4.8	8.3	5.0	8.6
Electrical Resistance @ 25°C±10%	Rm	Ohms L-L	1.9	0.63	2.6	0.87	3.5	1.2	4.4	1.5	6.2	2.1	8.0	2.7
Electrical Inductance ±20%	L	mh L-L	16.7	5.6	26.7	8.9	39.4	13.1	52.0	17.3	77.3	25.8	103	34.2
Back EMF Constant @25°C±10%	Ke	Vpeak/m/s L-L	30.9	17.8	51.4	29.7	77.1	44.5	103	59.3	154	89.0	206	119
		Vpeak/in/sec L-L	0.78	0.45	1.30	0.75	1.96	1.13	2.61	1.51	3.92	2.26	5.22	3.02
Force Constant @ 25°C±10%	Kf	N/Arms	37.8	21.8	62.9	36.3	94.4	54.5	126	72.7	189	109	252	145
		lbf/Arms	8.5	4.9	14.1	8.2	21.2	12.3	28.3	16.3	42.4	24.5	56.6	32.7
Mechanical Specifications														
Coil Assembly Weight ±15%	Mc	kg	2.5	3.6	5.0	6.5	9.4	12.3						
		lbs	5.5	7.9	11.0	14.3	20.7	27.1						
Magnetic Way Type			MC030	MC050	MC075	MC100	MC150	MC200						
Magnetic Way Weight ±15%	Mw	kg/m	5.4	7.5	10.1	12.7	20.7	26.8						
		lbs/in	0.30	0.42	0.56	0.71	1.16	1.50						
Figures of Merit and Additional Data														
Electrical TimeConstant	Te	ms	8.8	10.3	11.3	11.8	12.5	12.8						
Max.Theoretical Acceleration(3)	Amax	g's	15.3	17.7	19.2	19.6	20.3	20.7						
Magnetic Attraction	Fa	kN	1.4	2.4	3.7	4.9	7.3	9.9						
		lbf	324	546	821	1102	1639	2214						
Thermal Resistance (4) (coils to external structure)	Rth	°C/Watt	1.64	0.99	0.67	0.50	0.35	0.25						
Max. Allowable Coil Temp. (4)	Tmax	°C	130	130	130	130	130	130						

Notes:

1. The motor continuous rated force is measured with the motor coils achieving the motor maximum allowable temperature Tmax.
2. Alternate windings can be made available. Please consult the Kollmorgen Customer Support for design options.
3. Maximum theoretical acceleration is based on the motors peak force and the motor mass alone. Limitations due to such factors as the additional mass of the load, the bearing type and design, the shock rating of the feedback, the peak current available from the amplifier etc. must be considered to determine the achievable acceleration in each application.
4. Please see our application sizing pages in the back of this guide for more details on sizing and thermal considerations.

IC11 Outline Drawings

Ironcore Non-Cooled Motors Series

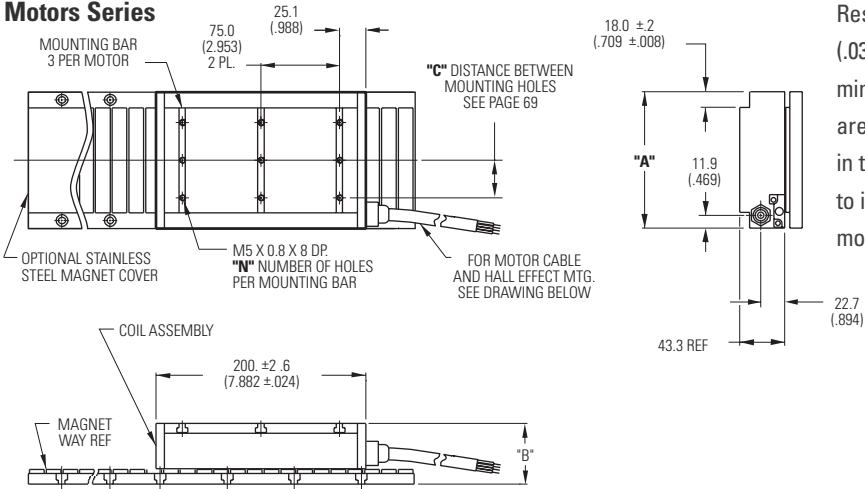

Resultant airgap = 0.9mm (.036) nominal (0.5mm (.020") minimum) when components are set up to dimension "B" in table below. (Please refer to installation manual for more detail)

Motor Coil Type	Coil Width "A"	Non-Cooled	Dim "B"		# Holes "N"
			without Cover	w/ Magnet Cover	
IC11-030	65.0 (2.559) ± 1.0 (.04)	ICXX-030	58.3±0.1 (2.295±.004)	58.6±0.1 (2.307±.004)	2
IC11-050	85.0 (3.346) ± 1.0 (.04)	ICXX-050	58.3±0.1 (2.295±.004)	58.6±0.1 (2.307±.004)	2
IC11-075	110.0 (4.331) ± 1.0 (.04)	ICXX-075	58.3±0.1 (2.295±.004)	58.6±0.1 (2.307±.004)	3
IC11-100	135.0 (5.315) ± 1.0 (.04)	ICXX-100	58.3±0.1 (2.295±.004)	58.6±0.1 (2.307±.004)	3
IC11-150	185.0 (7.283) ± 1.0 (.06)	ICXX-150	60.3±0.1 (2.374±.004)	60.6±0.1 (2.386±.004)	5
IC11-200	235.0 (9.252) ± 1.0 (.06)	ICXX-200	60.3±0.1 (2.374±.004)	60.6±0.1 (2.386±.004)	6

- Notes:
- Dimensions in mm (inches)
 - Tolerances unless otherwise specified:
 - no decimal place ±0.8 (0.3)
 - X decimal place ±0.1 (.004)
 - XX decimal place ±0.05 (0.002)

Termination and Hall Effect Options

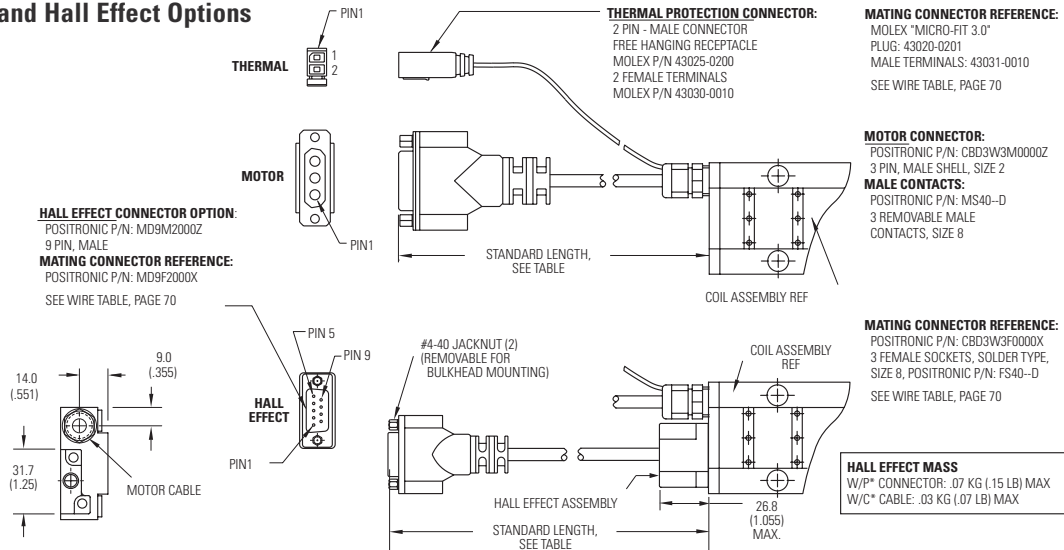

Connector Option	
Connector	Length
P1	400 (16)
P2	200 (8)
P3	100 (4)
P4	1200 (48)

Flying Lead Option	
Leads	Length
C1	400 (16)
C2	200 (8)
C3	100 (4)
C4	1200 (48)

Note: Cables exiting motor and hall effects are not dynamic flex cables. For high life flex extension cables, see page 72

IC22 Performance Data

Ironcore Non-Cooled Motors Series

Rated Performance	Symbol	Units	IC22-030			IC22-050			IC22-075		
Peak Force	Fp	N	624			1039			1558		
		lbf	140			234			350		
Continuous Force @ Tmax (1)	Fc	N	280			526			825		
		lbf	62.9			118			185		
Motor Constant @ 25°C	Km	N/√W	31.4			44.8			58.0		
Electrical Specifications (2)											
		Winding Code	A1	A2	A6	A1	A2	A6	A1	A2	A6
Peak Current	Ip	Arms	11.0	22.0	38.1	11.0	22.0	38.1	11.0	22.0	38.1
Continuous Current @Tmax	Ic	Arms	3.9	7.9	13.7	4.4	8.7	15.1	4.6	9.2	15.9
Electrical Resistance @ 25°C±10%	Rm	Ohms L-L	3.9	1.0	0.33	5.3	1.3	0.44	7.1	1.8	0.59
Electrical Inductance ±20%	L	mH L-L	33.4	8.4	2.8	53.4	13.4	4.5	78.9	19.7	6.6
Back EMF Constant @ 25°C±10%	Ke	Vpeak/m/s L-L	61.7	30.9	17.8	13	51.4	29.7	154	77.1	44.5
		Vpeak/in/sec L-L	1.57	0.78	0.45	2.61	1.31	0.75	3.92	1.96	1.13
Force Constant @ 25°C±10%	Kf	N/Arms	75.6	37.8	21.8	126	63.0	36.3	189	94.4	54.5
		lbf/Arms	17.0	8.5	4.9	28.3	14.2	8.2	42.4	21.2	12.3
Mechanical Specifications											
Coil Assembly Weight ±15%	Mc	kg	4.8			6.9			9.6		
		lbs	10.6			15.2			21.2		
Magnetic Way Type			MC030			MC050			MC075		
Magnetic Way Weight ±15%	Mw	kg/m	5.4			7.5			10.1		
		lb/in	0.30			0.42			0.56		
Figures of Merit and Additional Data											
Electrical Time Constant	Te	ms	8.6			10.1			11.1		
Max.Theoretical Acceleration(3)	Amax	g's	15.9			18.5			19.9		
Magnetic Attraction	Fa	kN	2.9			4.9			7.3		
		lbf	654			1090			1637		
Thermal Resistance (4) (coils to external structure)	Rth	°C/Watt	0.82			0.50			0.34		
Max. Allowable Coil Temp. (4)	Tmax	°C	130			130			130		

Notes:

1. The motor continuous rated force is measured with the motor coils achieving the motor maximum allowable temperature Tmax.
2. Alternate windings can be made available. Please consult the Kollmorgen Customer Support for design options.
3. Maximum theoretical acceleration is based on the motors peak force and the motor mass alone. Limitations due to such factors as the additional mass of the load, the bearing type and design, the shock rating of the feedback, the peak current available from the amplifier etc. must be considered to determine the achievable acceleration in each application.
4. Please see our application sizing pages in the back of this guide for more details on sizing and thermal considerations.

Rated Performance	Symbol	Units	IC22-100			IC22-150			IC22-200		
Peak Force	Fp	N	2077			3117			4156		
		lbf	467			701			934		
Continuous Force @ Tmax (1)	Fc	N	1148			1723			2393		
		lbf	258			387			538		
Motor Constant @ 25°C	Km	N/√W	69.5			87.8			103		
Electrical Specifications (2)											
		Winding Code	A1	A2	A6	A1	A2	A6	A1	A2	A6
Peak Current	Ip	Arms	11.0	22.0	38.1	11.0	22.0	38.1	11.0	22.0	38.1
Continuous Current @Tmax	Ic	Arms	4.8	9.5	16.5	4.8	9.6	16.6	5.0	10.0	17.3
Electrical Resistance @ 25°C±10%	Rm	Ohms L-L	8.8	2.2	0.73	12.4	3.1	1.0	15.9	4.0	1.3
Electrical Inductance ±20%	L	mH L-L	104	26.0	8.7	155	38.7	12.9	205	51.3	17.1
Back EMF Constant @ 25°C±10%	Ke	Vpeak/m/s L-L	206	103	59.3	308	154	89.0	411	206	119
		Vpeak/in/sec L-L	5.22	2.61	1.51	7.83	3.92	2.26	10.4	5.22	3.02
Force Constant @ 25°C±10%	Kf	N/Arms	252	126	72.7	378	189	109	504	252	145
		lbf/Arms	56.6	28.3	16.3	84.9	42.5	24.5	113	56.6	32.7
Mechanical Specifications											
Coil Assembly Weight ±15%	Mc	kg	12.5			18.1			23.7		
		lbs	27.6			39.9			52.2		
Magnetic Way Type			MC100			MC150			MC200		
Magnetic Way Weight ±15%	Mw	kg/m	12.7			20.7			26.8		
		lb/in	0.71			1.16			1.50		
Figures of Merit and Additional Data											
Electrical Time Constant	Te	ms	11.8			12.5			12.9		
Max.Theoretical Acceleration (3)	Amax	g's	20.4			21.1			21.5		
Magnetic Attraction	Fa	kN	9.8			14.6			19.7		
		lbf	2205			3271			4433		
Thermal Resistance (4) (coils to external structure)	Rth	°C/Watt	0.25			0.18			0.13		
Max. Allowable Coil Temp. (4)	Tmax	°C	130			130			130		

Notes:

- The motor continuous rated force is measured with the motor coils achieving the motor maximum allowable temperature Tmax.
- Alternate windings can be made available. Please consult the Kollmorgen Customer Support for design options.
- Maximum theoretical acceleration is based on the motors peak force and the motor mass alone. Limitations due to such factors as the additional mass of the load, the bearing type and design, the shock rating of the feedback, the peak current available from the amplifier etc. must be considered to determine the achievable acceleration in each application.
- Please see our application sizing pages in the back of this guide for more details on sizing and thermal considerations.

IC22 Series Outline Drawings

IC22 SERIES OUTLINE DRAWINGS

Ironcore Non-Cooled Motors Series

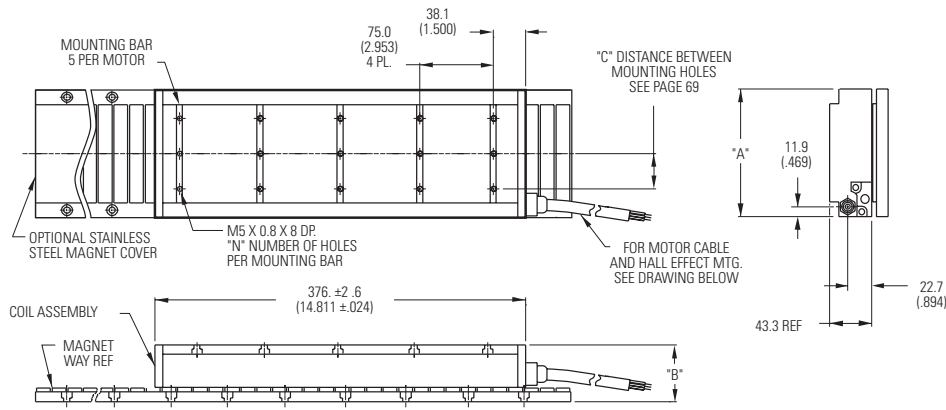

Resultant airgap = 0.9mm (.036) nominal (0.5mm (.020") minimum) when components are set up to dimension "B" in table below. (Please refer to installation manual for more detail)

Motor Coil Type	Coil Width "A"	Non-Cooled	Dim "B"		# Holes "N"
			without Cover	w/ Magnet Cover	
IC22-030	65.0 (2.559) ± 1.0 (.04)	ICXX-030	58.3±0.1 (2.295±.004)	58.6±0.1 (2.307±.004)	2
IC22-050	85.0 (3.346) ± 1.0 (.04)	ICXX-050	58.3±0.1 (2.295±.004)	58.6±0.1 (2.307±.004)	2
IC22-075	110.0 (4.331) ± 1.0 (.04)	ICXX-075	58.3±0.1 (2.295±.004)	58.6±0.1 (2.307±.004)	3
IC22-100	135.0 (5.315) ± 1.0 (.04)	ICXX-100	58.3±0.1 (2.295±.004)	58.6±0.1 (2.307±.004)	3
IC22-150	185.0 (7.283) ± 1.0 (.06)	ICXX-150	60.3±0.1 (2.374±.004)	60.6±0.1 (2.386±.004)	5
IC22-200	235.0 (9.252) ± 1.0 (.06)	ICXX-200	60.3±0.1 (2.374±.004)	60.6±0.1 (2.386±.004)	6

Notes:

1. Dimensions in mm (inches)
2. Tolerances unless otherwise specified: no decimal place ±0.8 (0.3) X decimal place ±0.1 (.004) XX decimal place ±0.05 (0.002)

Termination and Hall Effect Options

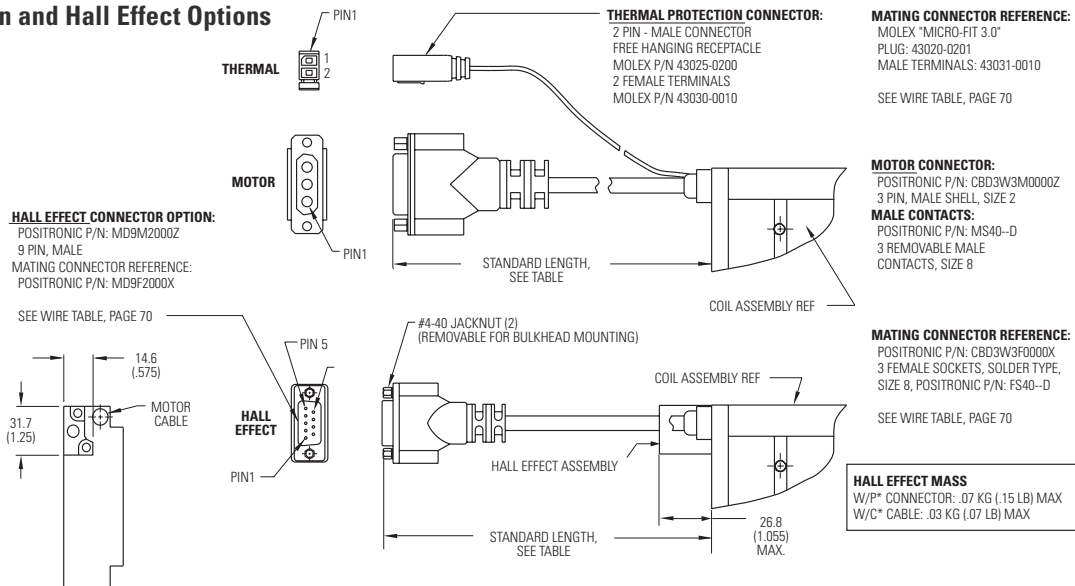

Connector Option	
Connector	Length
P1	400 (16)
P2	200 (8)
P3	100 (4)
P4	1200 (48)

Flying Lead Option	
Leads	Length
C1	400 (16)
C2	200 (8)
C3	100 (4)
C4	1200 (48)

Note:
Cables exiting motor and hall effects are not dynamic flex cables. For high life flex extension cables, see page 72

Notes

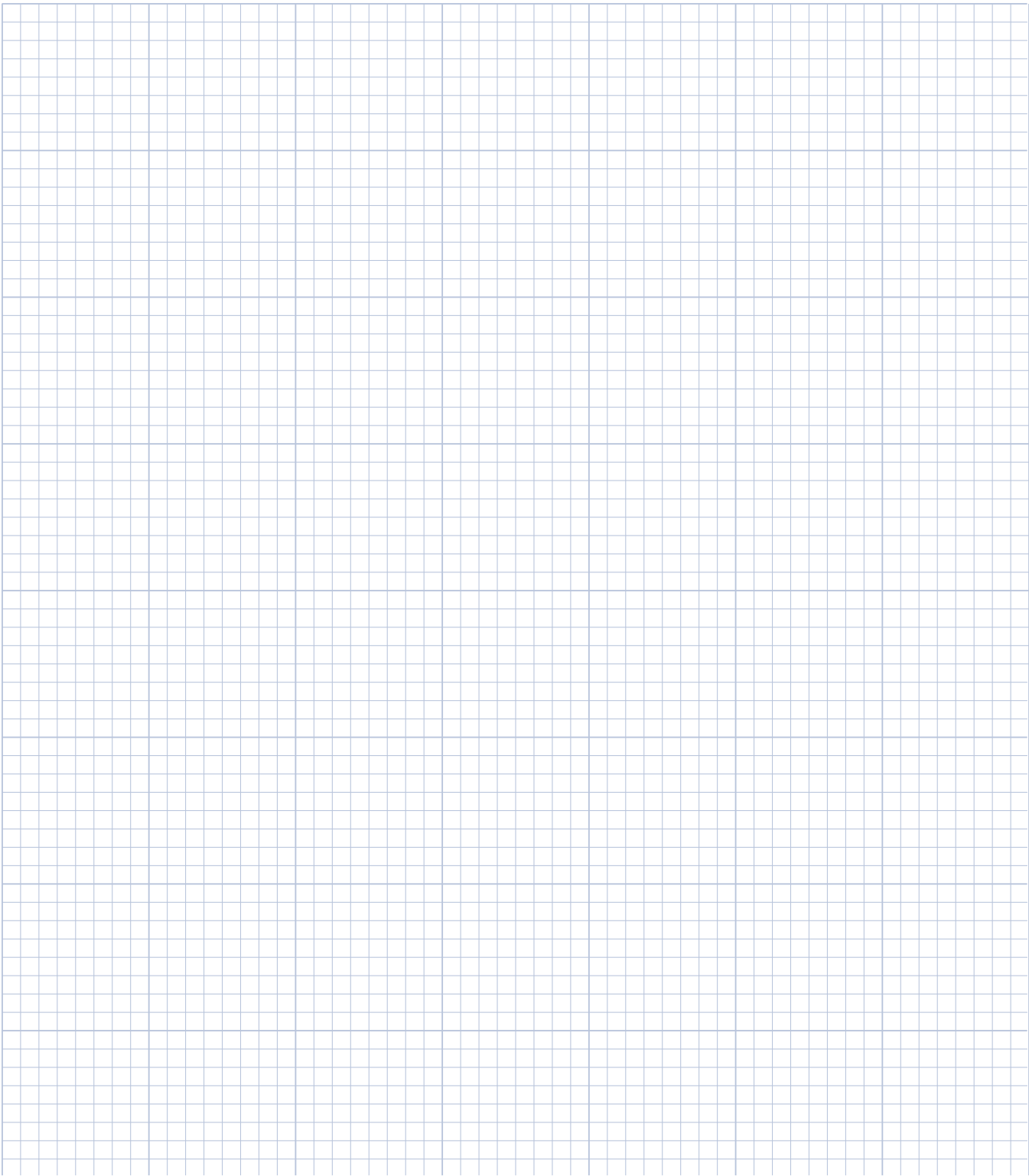

IC33 Performance Data

Ironcore Non-Cooled Motors Series

Rated Performance	Symbol	Units	IC33-030				IC33-050				IC33-075			
Peak Force	Fp	N	944				1572				2358			
		lbf	212				353				530			
Continuous Force @ Tmax (1)	Fc	N	431				789				1238			
		lbf	96.9				177				278			
Motor Constant @ 25°C	Km	N/√W	38.5				55.0				71.2			
Electrical Specifications (2)														
		Winding Code	A1	A3	A5	A7	A1	A3	A5	A7	A1	A3	A5	A7
Peak Current	Ip	Arms	11.1	33.1	19.1	57.3	11.1	33.1	19.1	57.3	11.1	33.1	19.1	57.3
Continuous Current @Tmax	Ic	Arms	4.0	11.9	6.9	20.6	4.4	13.1	7.6	22.7	4.6	13.8	8.0	23.9
Electrical Resistance @ 25°C±10%	Rm	Ohms L-L	5.8	0.64	1.9	0.21	7.9	0.88	2.6	0.29	10.6	1.2	3.5	0.39
Electrical Inductance ±20%	L	mh L-L	50.1	5.6	16.7	1.9	80.2	8.9	26.7	3.0	118	13.1	39.4	4.4
Back EMF Constant @25°C±10%	Ke	Vpeak/m/s L-L	92.6	30.9	53.5	17.8	154	51.4	89.0	29.7	231	77.1	134	44.5
		Vpeak/in/sec L-L	2.35	0.78	1.36	0.45	3.92	1.31	2.26	0.75	5.88	1.96	3.39	1.13
Force Constant @ 25°C±10%	Kf	N/Arms	113	37.8	65.5	21.8	189	62.9	109	36.3	283	94.4	164	54.5
		lbf/Arms	25.5	8.5	14.7	4.9	42.4	14.1	24.5	8.2	63.7	21.2	36.8	12.3
Mechanical Specifications														
Coil Assembly Weight ±15%	Mc	kg	7.3				10.4				14.4			
		lbs	16.1				22.9				31.7			
Magnetic Way Type			MC030				MC050				MC075			
Magnetic Way Weight ±15%	Mw	kg/m	5.4				7.5				10.1			
		lbs/in	0.30				0.42				0.56			
Figures of Merit and Additional Data														
Electrical Time Constant	Te	ms	8.6				10.2				11.2			
Max.Theoretical Acceleration(3)	Amax	g's	15.7				18.4				19.9			
Magnetic Attraction	Fa	kN	4.4				7.4				11.0			
		lbf	991				1652				2480			
Thermal Resistance (4) (coils to external structure)	Rth	°C/Watt	0.55				0.33				0.22			
Max. Allowable Coil Temp. (4)	Tmax	°C	130				130				130			

Notes:

1. The motor continuous rated force is measured with the motor coils achieving the motor maximum allowable temperature Tmax.
2. Alternate windings can be made available. Please consult the Kollmorgen Customer Support for design options.
3. Maximum theoretical acceleration is based on the motors peak force and the motor mass alone. Limitations due to such factors as the additional mass of the load, the bearing type and design, the shock rating of the feedback, the peak current available from the amplifier etc. must be considered to determine the achievable acceleration in each application.
4. Please see our application sizing pages in the back of this guide for more details on sizing and thermal considerations.

Rated Performance	Symbol	Units	IC33-100				IC33-150				IC33-200			
Peak Force	Fp	N	3144				4716				6291			
		lbf	707				1060				1414			
Continuous Force @ Tmax (1)	Fc	N	1722				2583				3590			
		lbf	387				581				807			
Motor Constant @ 25°C	Km	N/√W	85.1				108				127			
Electrical Specifications (2)														
		Winding Code	A1	A3	A5	A7	A1	A3	A5	A7	A1	A3	A5	A7
Peak Current	Ip	Arms	11.1	33.1	19.1	57.3	11.1	33.1	19.1	57.3	11.1	33.1	19.1	57.3
Continuous Current @Tmax	Ic	Arms	4.8	14.3	8.2	24.7	4.8	14.4	8.3	24.9	5.0	14.9	8.6	25.9
Electrical Resistance @ 25°C±10%	Rm	Ohms L-L	13.2	1.5	4.4	0.49	18.5	2.1	6.2	0.69	23.9	2.7	8.0	0.89
Electrical Inductance ±20%	L	mh L-L	156	17.3	52.0	5.8	232	25.8	77.3	8.6	308	34.2	103	11.4
Back EMF Constant @25°C±10%	Ke	Vpeak/m/s L-L	308	103	178	59.3	463	154	267	89.0	617	206	356	119
		Vpeak/in/sec L-L	7.83	2.61	4.52	1.51	11.7	3.92	6.78	2.26	15.7	5.22	9.05	3.02
Force Constant @ 25°C±10%	Kf	N/Arms	378	126	218	72.7	567	189	327	109	756	252	436	145
		lbf/Arms	84.9	28.3	49.0	16.3	127	42.5	73.5	24.5	170	56.6	98.1	32.7
Mechanical Specifications														
Coil Assembly Weight ±15%	Mc	kg	18.9				27.3				35.7			
		lbs	41.7				60.2				78.7			
Magnetic Way Type			MC100				MC150				MC200			
Magnetic Way Weight ±15%	Mw	kg/m	12.7				20.7				26.8			
		lbs/in	0.71				1.16				1.50			
Figures of Merit and Additional Data														
Electrical Time Constant	Te	ms	11.8				12.5				12.9			
Max.Theoretical Acceleration(3)	Amax	g's	20.2				21.0				21.4			
Magnetic Attraction	Fa	kN	14.7				22.1				29.4			
		lbf	3305				4957				6609			
Thermal Resistance (4) (coils to external structure)	Rth	°C/Watt	0.17				0.12				0.084			
Max. Allowable Coil Temp. (4)	Tmax	°C	130				130				130			

Notes:

- The motor continuous rated force is measured with the motor coils achieving the motor maximum allowable temperature Tmax.
- Alternate windings can be made available. Please consult the Kollmorgen Customer Support for design options.
- Maximum theoretical acceleration is based on the motors peak force and the motor mass alone. Limitations due to such factors as the additional mass of the load, the bearing type and design, the shock rating of the feedback, the peak current available from the amplifier etc. must be considered to determine the achievable acceleration in each application.
- Please see our application sizing pages in the back of this guide for more details on sizing and thermal considerations.

IC33 Series Outline Drawings

IC33 SERIES OUTLINE DRAWINGS

Ironcore Non-Cooled Motors Series

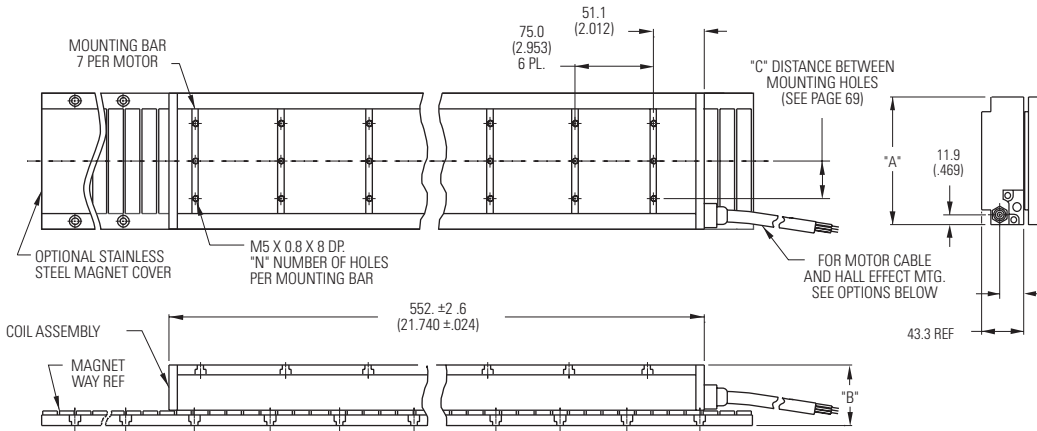

Resultant airgap = 0.9mm (.036) nominal (0.5mm (.020") minimum) when components are set up to dimension "B" in table below. (Please refer to installation manual for more detail)

Motor Coil Type	Coil Width "A"	Non-Cooled	Dim "B"		# Holes "N"
			without Cover	w/ Magnet Cover	
IC33-030	65.0 (2.559) ± 1.0 (.04)	ICXX-030	58.3±0.1 (2.295±.004)	58.6±0.1 (2.307±.004)	2
IC33-050	85.0 (3.346) ± 1.0 (.04)	ICXX-050	58.3±0.1 (2.295±.004)	58.6±0.1 (2.307±.004)	2
IC33-075	110.0 (4.331) ± 1.0 (.04)	ICXX-075	58.3±0.1 (2.295±.004)	58.6±0.1 (2.307±.004)	3
IC33-100	135.0 (5.315) ± 1.0 (.04)	ICXX-100	58.3±0.1 (2.295±.004)	58.6±0.1 (2.307±.004)	3
IC33-150	185.0 (7.283) ± 1.0 (.06)	ICXX-150	60.3±0.1 (2.374±.004)	60.6±0.1 (2.386±.004)	5
IC33-200	235.0 (9.252) ± 1.0 (.06)	ICXX-200	60.3±0.1 (2.374±.004)	60.6±0.1 (2.386±.004)	6

- Notes:
- Dimensions in mm (inches)
 - Tolerances unless otherwise specified: no decimal place ±0.8 (0.3) X decimal place ±0.1 (.004) XX decimal place ±0.05 (0.002)

Termination and Hall Effect Options

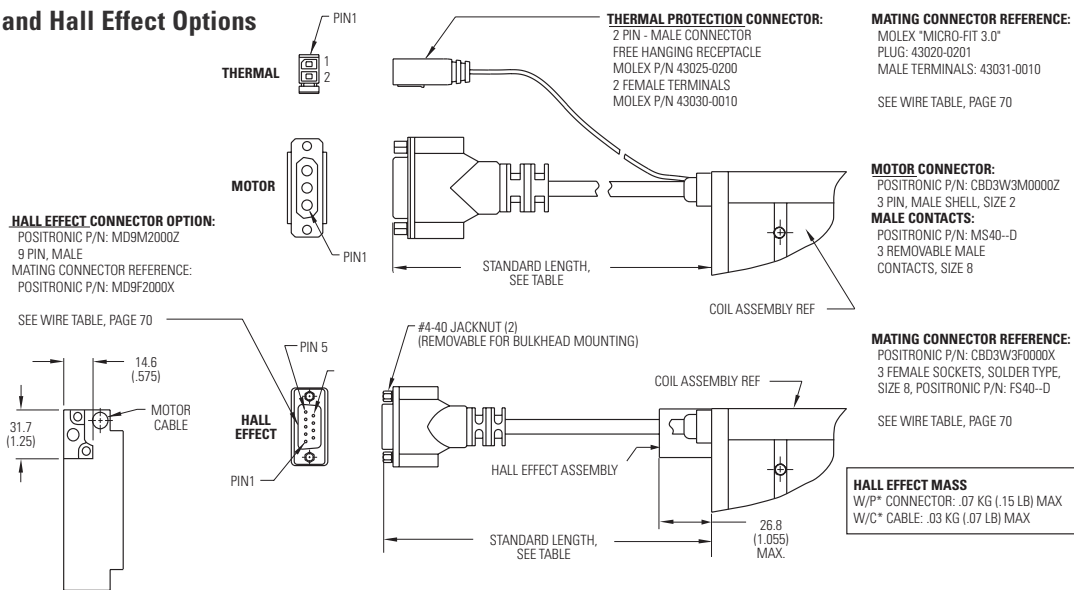

Connector Option	
Connector	Length
P1	400 (16)
P2	200 (8)
P3	100 (4)
P4	1200 (48)

Flying Lead Option	
Leads	Length
C1	400 (16)
C2	200 (8)
C3	100 (4)
C4	1200 (48)

Note: Cables exiting motor and hall effects are not dynamic flex cables. For high life flex extension cables, see page 72

Notes

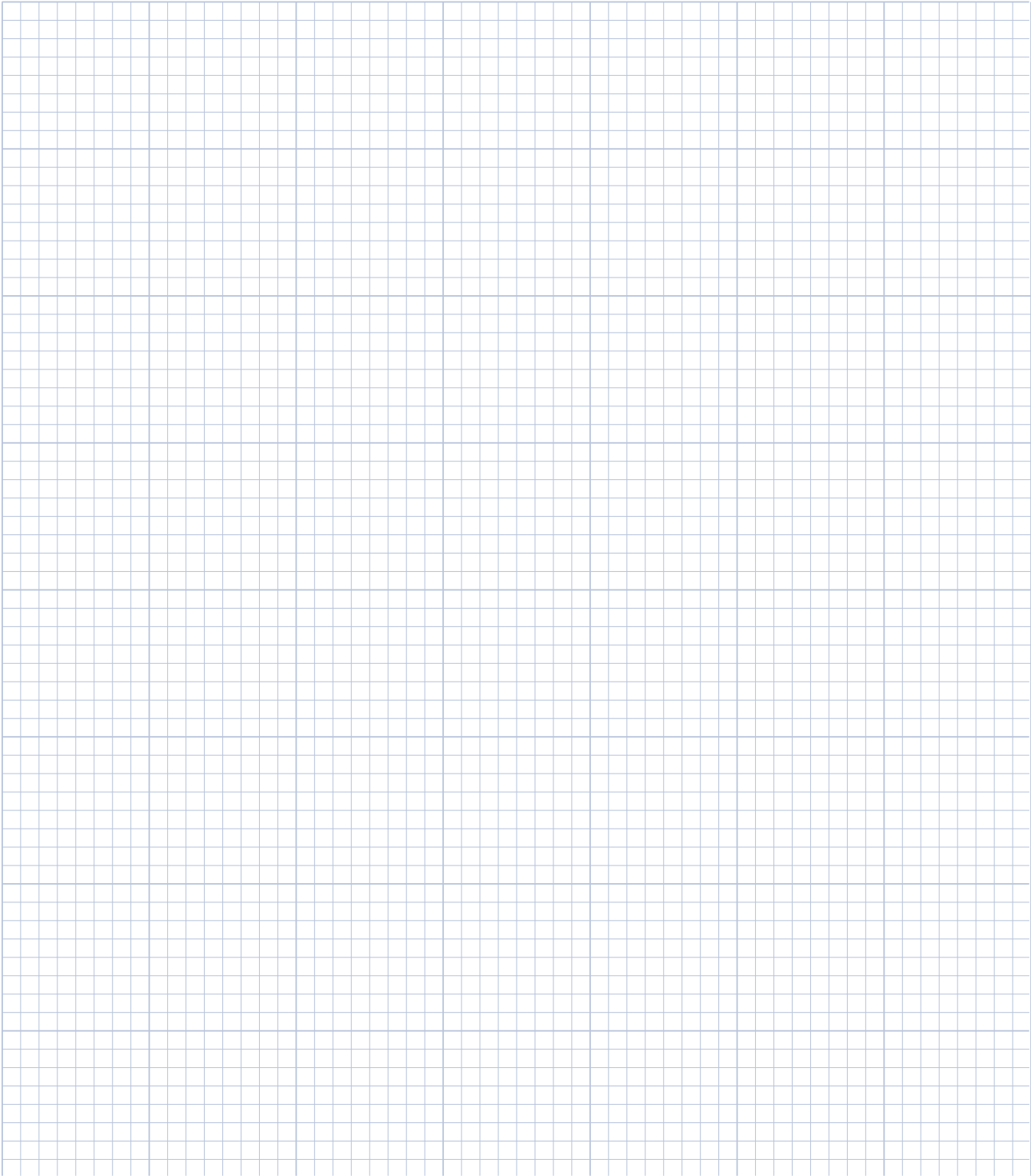

IC44 Performance Data

Ironcore Non-Cooled Motors Series

Rated Performance	Symbol	Units	IC44-030				IC44-050				IC44-075			
Peak Force	Fp	N	1259				2096				3144			
		lbf	283				471				707			
Continuous Force @ Tmax (1)	Fc	N	560				1053				1651			
		lbf	126				237				371			
Motor Constant @ 25°C	Km	N/√W	44.3				63.3				82.4			
Electrical Specifications (2)														
		Winding Code	A1	A2	A3	A7	A1	A2	A3	A7	A1	A2	A3	A7
Peak Current	Ip	Arms	11.1	22.1	44.1	76.4	11.1	22.1	44.1	76.4	11.1	22.1	44.1	76.4
Continuous Current @Tmax	Ic	Arms	3.9	7.9	15.8	27.3	4.4	8.7	17.4	30.2	4.6	9.2	18.3	31.8
Electrical Resistance @ 25°C±10%	Rm	Ohms L-L	7.8	2.0	0.49	0.16	10.6	2.7	0.66	0.22	14.1	3.5	0.88	0.29
Electrical Inductance ±20%	L	mh L-L	66.8	16.7	4.2	1.4	107	26.7	6.7	2.2	158	39.4	9.9	3.3
Back EMF Constant @25°C±10%	Ke	Vpeak/m/s L-L	123	61.7	30.9	17.8	206	103	51.4	29.7	308	154	77.1	44.5
		Vpeak/in/sec L-L	3.14	1.57	0.78	0.45	5.22	2.61	1.31	0.75	7.83	3.92	1.96	1.13
Force Constant @ 25°C±10%	Kf	N/Arms	151	75.6	37.8	21.8	252	126	63.0	36.3	378	189	94.4	54.5
		lbf/Arms	34.0	17.0	8.5	4.9	56.6	28.3	14.2	8.2	84.9	42.5	21.2	12.3
Mechanical Specifications														
Coil Assembly Weight ±15%	Mc	kg	9.6				13.9				19.2			
		lbs	21.2				30.6				42.3			
Magnetic Way Type			MC030				MC050				MC075			
Magnetic Way Weight ±15%	Mw	kg/m	5.4				7.5				10.1			
		lbs/in	0.30				0.42				0.56			
Figures of Merit and Additional Data														
Electrical Time Constant	Te	ms	8.6				10.1				11.2			
Max.Theoretical Acceleration(3)	Amax	g's	15.9				18.3				19.9			
Magnetic Attraction	Fa	kN	5.9				9.8				14.7			
		lbf	1322				2203				3305			
Thermal Resistance (4) (coils to external structure)	Rth	°C/Watt	0.41				0.25				0.17			
Max. Allowable Coil Temp. (4)	Tmax	°C	130				130				130			

Notes:

1. The motor continuous rated force is measured with the motor coils achieving the motor maximum allowable temperature Tmax.
2. Alternate windings can be made available. Please consult the Kollmorgen Customer Support for design options.
3. Maximum theoretical acceleration is based on the motors peak force and the motor mass alone. Limitations due to such factors as the additional mass of the load, the bearing type and design, the shock rating of the feedback, the peak current available from the amplifier etc. must be considered to determine the achievable acceleration in each application.
4. Please see our application sizing pages in the back of this guide for more details on sizing and thermal considerations.

Rated Performance	Symbol	Units	IC44-100				IC44-150				IC44-200			
Peak Force	Fp	N	4192				6289				8388			
		lbf	942				1414				1885			
Continuous Force @ Tmax (1)	Fc	N	2296				3445				4786			
		lbf	516				774				1076			
Motor Constant @ 25°C	Km	N/√W	98.3				124				146			
Electrical Specifications (2)														
		Winding Code	A1	A2	A3	A7	A1	A2	A3	A7	A1	A2	A3	A7
Peak Current	Ip	Arms	11.1	22.1	44.1	76.4	11.1	22.1	44.1	76.4	11.1	22.1	44.1	76.4
Continuous Current @Tmax	Ic	Arms	4.8	9.5	19.0	33.0	4.8	9.6	19.2	33.2	5.0	10.0	20.0	34.6
Electrical Resistance @ 25°C±10%	Rm	Ohms L-L	17.6	4.4	1.1	0.37	24.7	6.2	1.5	0.51	31.8	8.0	2.0	0.66
Electrical Inductance ±20%	L	mh L-L	208	52.1	13.0	4.3	309	77.4	19.3	6.4	410	103	25.7	8.6
Back EMF Constant @25°C±10%	Ke	Vpeak/m/s L-L	411	206	103	59.3	617	308	154	89.0	823	411	206	119
		Vpeak/in/sec L-L	10.4	5.22	2.61	1.51	15.7	7.83	3.92	2.26	20.9	10.4	5.22	3.02
Force Constant @ 25°C±10%	Kf	N/Arms	504	252	126	72.7	755	378	189	109	1008	504	252	145
		lbf/Arms	113	56.6	28.3	16.3	170	84.9	42.5	24.5	227	113	56.6	32.7
Mechanical Specifications														
Coil Assembly Weight ±15%	Mc	kg	25.0				36.2				47.4			
		lbs	55.1				79.8				104			
Magnetic Way Type			MC100				MC150				MC200			
Magnetic Way Weight ±15%	Mw	kg/m	12.7				20.7				26.8			
		lbs/in	0.71				1.16				1.50			
Figures of Merit and Additional Data														
Electrical Time Constant	Te	ms	11.8				12.5				12.9			
Max.Theoretical Acceleration(3)	Amax	g's	20.4				21.1				21.5			
Magnetic Attraction	Fa	kN	19.6				29.4				39.4			
		lbf	4406				6609				8858			
Thermal Resistance (coils to external structure)	Rth	°C/Watt	0.13				0.088				0.063			
Max. Allowable Coil Temp. (4)	Tmax	°C	130				130				130			

Notes:

1. The motor continuous rated force is measured with the motor coils achieving the motor maximum allowable temperature Tmax.
2. Alternate windings can be made available. Please consult the Kollmorgen Customer Support for design options.
3. Maximum theoretical acceleration is based on the motors peak force and the motor mass alone. Limitations due to such factors as the additional mass of the load, the bearing type and design, the shock rating of the feedback, the peak current available from the amplifier etc. must be considered to determine the achievable acceleration in each application.
4. Please see our application sizing pages in the back of this guide for more details on sizing and thermal considerations.

IC44 Series Outline Drawings

Ironcore Non-Cooled Motors Series

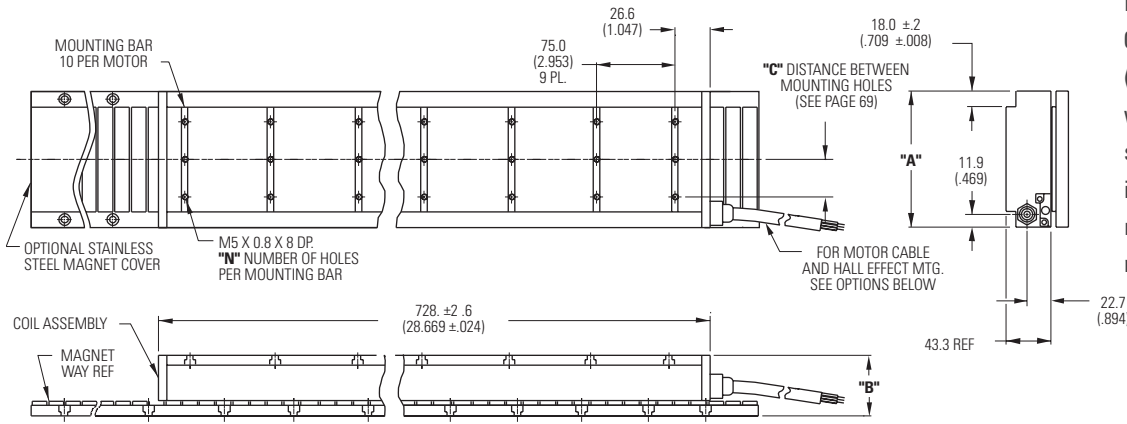

Resultant airgap = 0.9mm (.036) nominal (0.5mm (.020") minimum) when components are set up to dimension "B" in table below. (Please refer to installation manual for more detail)

Motor Coil Type	Coil Width "A"	Non-Cooled	Dim "B"		# Holes "N"
			without Cover	w/ Magnet Cover	
IC44-030	65.0 (2.559) ± 1.0 (.04)	ICXX-030	58.3±0.1 (2.295±.004)	58.6±0.1 (2.307±.004)	2
IC44-050	85.0 (3.346) ± 1.0 (.04)	ICXX-050	58.3±0.1 (2.295±.004)	58.6±0.1 (2.307±.004)	2
IC44-075	110.0 (4.331) ± 1.0 (.04)	ICXX-075	58.3±0.1 (2.295±.004)	58.6±0.1 (2.307±.004)	3
IC44-100	135.0 (5.315) ± 1.0 (.04)	ICXX-100	58.3±0.1 (2.295±.004)	58.6±0.1 (2.307±.004)	3
IC44-150	185.0 (7.283) ± 1.0 (.06)	ICXX-150	60.3±0.1 (2.374±.004)	60.6±0.1 (2.386±.004)	5
IC44-200	235.0 (9.252) ± 1.0 (.06)	ICXX-200	60.3±0.1 (2.374±.004)	60.6±0.1 (2.386±.004)	6

- Notes:
1. Dimensions in mm (inches)
 2. Tolerances unless otherwise specified: no decimal place ±0.8 (0.3) X decimal place ±0.1 (.004) XX decimal place ±0.05 (0.002)

Termination and Hall Effect Options

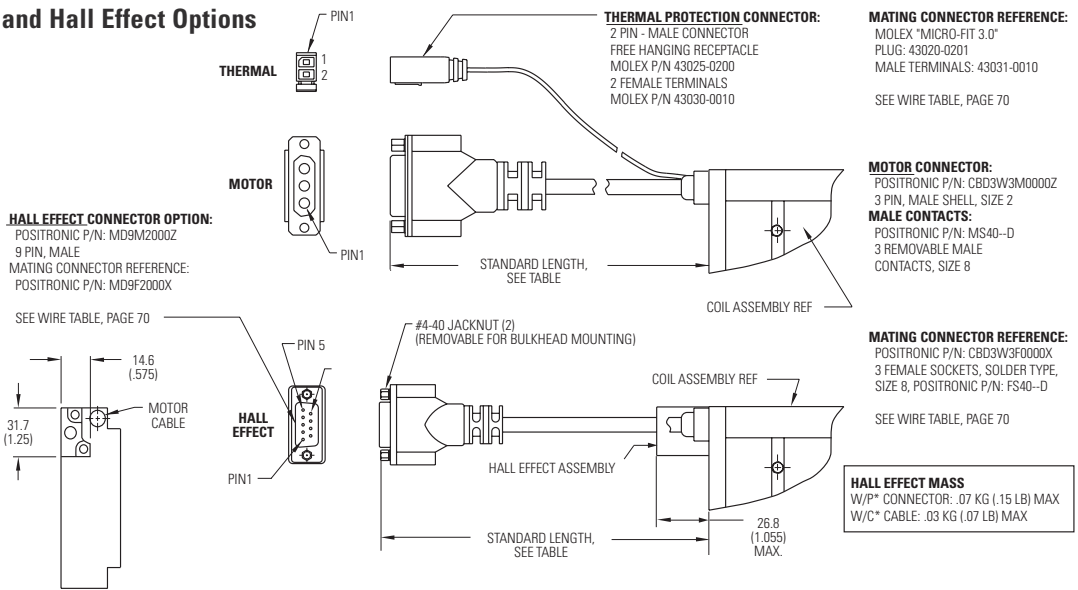

Connector Option	
Connector	Length
P1	400 (16)
P2	200 (8)
P3	100 (4)
P4	1200 (48)

Flying Lead Option	
Leads	Length
C1	400 (16)
C2	200 (8)
C3	100 (4)
C4	1200 (48)

Note: Cables exiting motor and hall effects are not dynamic flex cables. For high life flex extension cables, see page 72

HALL EFFECT MASS
W/P* CONNECTOR: .07 KG (.15 LB) MAX
W/C* CABLE: .03 KG (.07 LB) MAX

Notes

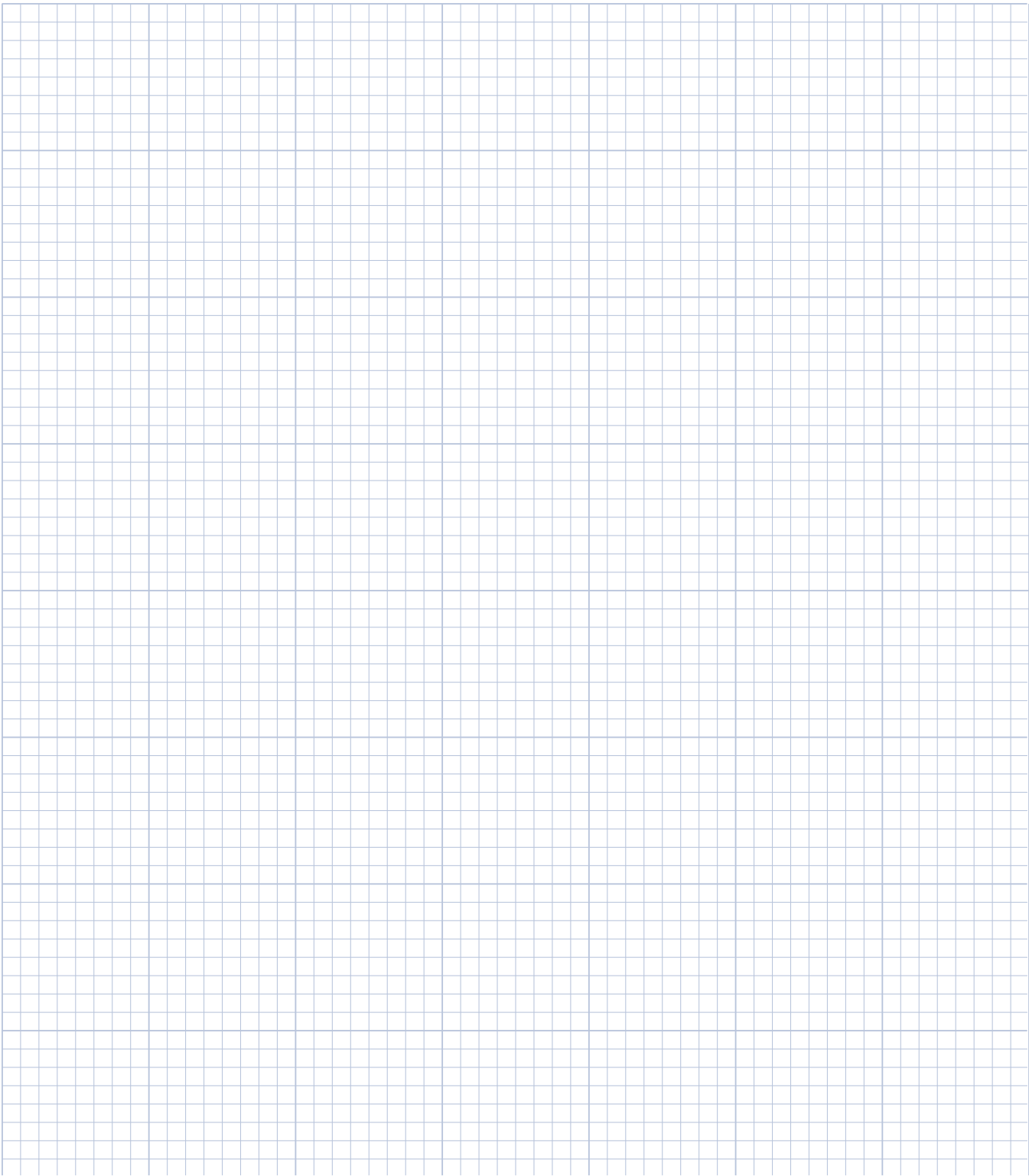

IC11 Performance Data

Ironcore Water-Cooled Motors Series

Rated Performance	Symbol	Units	IC11-030	IC11-050	IC11-075	IC11-100	IC11-150	IC11-200						
Peak Force	Fp	N	315	525	798	1051	1576	2102						
		lbf	70.8	118	179	236	354	473						
Continuous Force @ Tmax (1)	Fc	N	254	432	649	864	1285	1712						
		lbf	57.1	97.1	146	194	289	385						
Motor Constant @ 25°C	Km	N/√W	19.3	28.6	37.3	45.0	55.7	65.7						
Electrical Specifications (2)														
		Winding Code	A1	A5	A1	A5	A1	A5	A1	A5	A1	A5	A1	A5
Peak Current	Ip	Arms	13.8	23.9	13.8	23.9	13.8	23.9	13.8	23.9	13.8	23.9	13.8	23.9
Continuous Current @Tmax	Ic	Arms	9.7	16.9	9.9	17.2	9.9	17.1	9.9	17.2	9.8	17.0	9.8	17.0
Electrical Resistance @ 25°C±10%	Rm	Ohms L-L	1.6	0.53	2.1	0.70	2.8	0.93	3.5	1.2	5.0	1.7	6.4	2.1
Electrical Inductance ±20%	L	mh L-L	10.3	3.4	16.5	5.5	24.4	8.1	32.1	10.7	47.7	15.9	63.3	21.1
Back EMF Constant @25°C±10%	Ke	Vpeak/m/s L-L	24.8	14.3	41.4	23.9	62.2	35.9	82.9	47.8	124	71.7	166	95.7
		Vpeak/in/sec L-L	0.63	0.36	1.05	0.61	1.58	0.91	2.11	1.22	3.16	1.82	4.21	2.43
Force Constant @ 25°C±10%	Kf	N/Arms	30.4	17.6	50.7	29.3	76.2	44.0	102	58.6	152	87.9	203	117
		lbf/Arms	6.8	3.9	11.4	6.6	17.1	9.9	22.8	13.2	34.2	19.8	45.7	26.4
Mechanical Specifications														
Coil Assembly Weight ±15%	Mc	kg	2.5	3.6	5.0	6.5	9.4	12.3						
		lbs	5.5	7.9	11.0	14.3	20.7	27.1						
Magnetic Way Type			MC030	MC050	MC075	MC100	MC150	MC200						
Magnetic Way Weight±15%	Mw	kg/m	5.4	7.5	10.1	12.7	20.7	26.8						
		lbs/in	0.30	0.42	0.56	0.71	1.16	1.50						
Figures of Merit and Additional Data														
Electrical TimeConstant	Te	ms	6.4	7.9	8.7	9.2	9.5	9.9						
Max.Theoretical Acceleration(3)	Amax	g's	15.3	17.7	19.2	19.6	20.3	20.7						
Magnetic Attraction	Fa	kN	1.4	2.4	3.7	4.9	7.3	9.9						
		lbf	324	546	821	1102	1639	2214						
Thermal Resistance (4) (coils to external structure)	Rth	°C/Watt	0.33	0.24	0.18	0.15	0.10	0.081						
Max. Allowable Coil Temp. (4)	Tmax	°C	130	130	130	130	130	130						
Min. Flow Rate of Coolant at a Max. Temperature of 25°C		liters/min.	2.8	2.8	2.8	2.8	2.8	2.8						

Notes:

1. The motor continuous rated force is measured with the motor coils achieving the motor maximum allowable temperature Tmax.
2. Alternate windings can be made available. Please consult the Kollmorgen Customer Support for design options.
3. Maximum theoretical acceleration is based on the motors peak force and the motor mass alone. Limitations due to such factors as the additional mass of the load, the bearing type and design, the shock rating of the feedback, the peak current available from the amplifier etc. must be considered to determine the achievable acceleration in each application.
4. Please see our application sizing pages in the back of this guide for more details on sizing and thermal considerations.

IC11 Outline Drawings

Ironcore Water-Cooled Motors Series

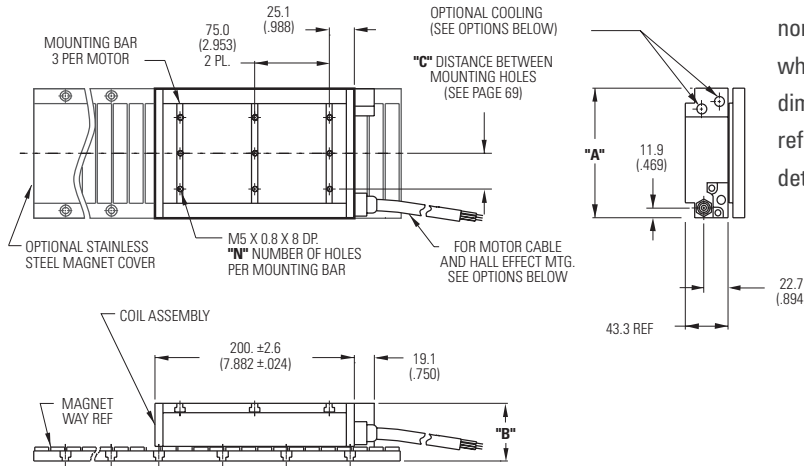

Resultant airgap = 0.9mm (.036) nominal (0.5mm (.020") minimum) when components are set up to dimension "B" in table below. (Please refer to installation manual for more detail)

Motor Coil Type	Coil Width "A"	Cooled	Dim "B"		# Holes "N"
			without Cover	w/ Magnet Cover	
IC11-030	65.0 (2.559) ± 1.0 (.04)	ICXX-030	58.3±0.1 (2.295±.004)	58.6±0.1 (2.307±.004)	2
IC11-050	85.0 (3.346) ± 1.0 (.04)	ICXX-050	58.3±0.1 (2.295±.004)	58.6±0.1 (2.307±.004)	2
IC11-075	110.0 (4.331) ± 1.0 (.04)	ICXX-075	58.3±0.1 (2.295±.004)	58.6±0.1 (2.307±.004)	3
IC11-100	135.0 (5.315) ± 1.0 (.04)	ICXX-100	58.3±0.1 (2.295±.004)	58.6±0.1 (2.307±.004)	3
IC11-150	185.0 (7.283) ± 1.0 (.06)	ICXX-150	60.3±0.1 (2.374±.004)	60.6±0.1 (2.386±.004)	5
IC11-200	235.0 (9.252) ± 1.0 (.06)	ICXX-200	60.3±0.1 (2.374±.004)	60.6±0.1 (2.386±.004)	6

- Notes:
- Dimensions in mm (inches)
 - Tolerances unless otherwise specified:
 - no decimal place ±0.8 (0.3)
 - X decimal place ±0.1 (.004)
 - XX decimal place ±0.05 (0.002)

Termination and Hall Effect Options

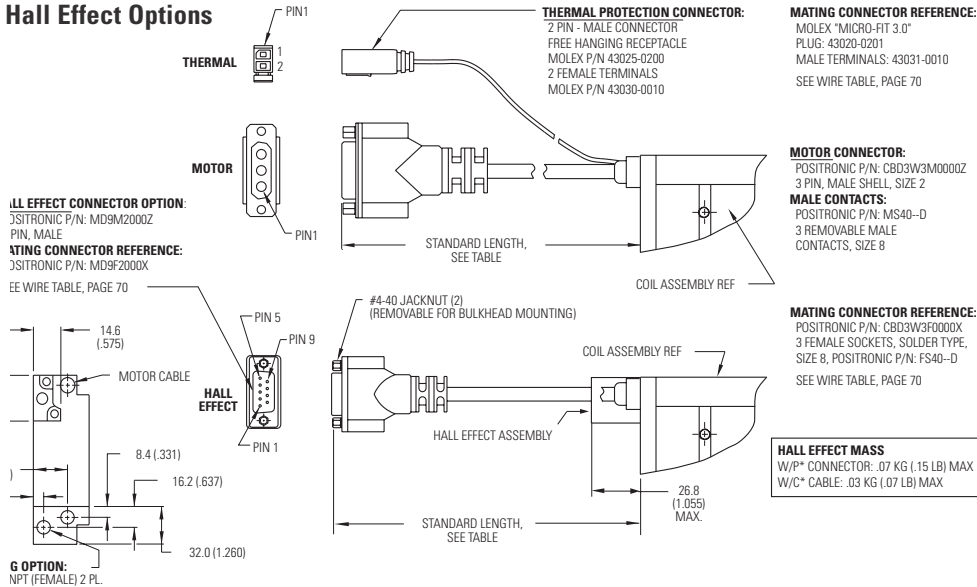

Connector Option			
Connector	Length		
P1	400 (16)	C1	400 (16)
P2	200 (8)	C2	200 (8)
P3	100 (4)	C3	100 (4)
P4	1200 (48)	C4	1200 (48)

Note: Cables exiting motor and hall effects are not dynamic flex cables. For high life flex extension cables, see page 72

IC22 Performance Data

Ironcore Water-Cooled Motors Series

Rated Performance	Symbol	Units	IC22-030			IC22-050			IC22-075		
Peak Force	Fp	N	630			1051			1576		
		lbf	142			236			354		
Continuous Force @ Tmax (1)	Fc	N	519			864			1284		
		lbf	117			194			287		
Motor Constant @ 25°C	Km	N/√W	28.3			40.5			52.2		
Electrical Specifications (2)											
		Winding Code	A1	A2	A6	A1	A2	A6	A1	A2	A6
Peak Current	Ip	Arms	13.8	27.6	47.8	13.8	27.6	47.8	13.8	27.6	47.8
Continuous Current @Tmax	Ic	Arms	9.9	19.8	34.3	9.9	19.8	34.3	9.8	19.6	34.0
Electrical Resistance @ 25°C±10%	Rm	Ohms L-L	3.1	0.78	0.26	4.2	1.1	0.35	5.7	1.4	0.48
Electrical Inductance ±20%	L	mH L-L	20.6	5.2	1.7	33.0	8.3	2.8	48.6	12.2	4.1
Back EMF Constant @ 25°C±10%	Ke	Vpeak/m/s L-L	49.7	24.9	14.4	82.9	41.4	23.9	124	62.2	35.9
		Vpeak/in/sec L-L	1.26	0.63	0.36	2.11	1.05	0.61	3.16	1.58	0.91
Force Constant @ 25°C±10%	Kf	N/Arms	60.9	30.5	17.6	102	50.8	29.3	152	76.2	44.0
		lbf/Arms	13.7	6.8	4.0	22.8	11.4	6.6	34.2	17.1	9.9
Mechanical Specifications											
Coil Assembly Weight ±15%	Mc	kg	4.8			6.9			9.6		
		lbs	10.6			15.2			21.2		
Magnetic Way Type			MC030			MC050			MC075		
Magnetic Way Weight ±15%	Mw	kg/m	5.4			7.5			10.1		
		lb/in	0.30			0.42			0.56		
Figures of Merit and Additional Data											
Electrical Time Constant	Te	ms	6.6			7.9			8.5		
Max.Theoretical Acceleration (3)	Amax	g's	15.9			18.5			19.9		
Magnetic Attraction	Fa	kN	2.9			4.9			7.3		
		lbf	654			1090			1637		
Thermal Resistance (4) (coils to external structure)	Rth	°C/Watt	0.16			0.12			0.091		
Max. Allowable Coil Temp. (4)	Tmax	°C	130			130			130		
Min. Flow Rate of Coolant at a Max. Temperature of 25°C		liters/min.	2.8			2.8			2.8		

Notes:

- The motor continuous rated force is measured with the motor coils achieving the motor maximum allowable temperature Tmax.
- Alternate windings can be made available. Please consult the Kollmorgen Customer Support for design options.
- Maximum theoretical acceleration is based on the motors peak force and the motor mass alone. Limitations due to such factors as the additional mass of the load, the bearing type and design, the shock rating of the feedback, the peak current available from the amplifier etc. must be considered to determine the achievable acceleration in each application.
- Please see our application sizing pages in the back of this guide for more details on sizing and thermal considerations.

Rated Performance	Symbol	Units	IC22-100			IC22-150			IC22-200		
Peak Force	Fp	N	2106			3152			4204		
		lbf	473			709			945		
Continuous Force @ Tmax (1)	Fc	N	1715			2566			3458		
		lbf	386			577			777		
Motor Constant @ 25°C	Km	N/√W	62.5			79.3			93.3		
Electrical Specifications (2)											
		Winding Code	A1	A2	A6	A1	A2	A6	A1	A2	A6
Peak Current	Ip	Arms	13.8	27.6	47.8	13.8	27.6	47.8	13.8	27.6	47.8
Continuous Current @Tmax	Ic	Arms	9.8	19.6	34.0	9.8	19.7	34.1	9.9	19.8	34.3
Electrical Resistance @ 25°C±10%	Rm	Ohms L-L	7.1	1.8	0.59	9.9	2.5	0.83	12.7	3.2	1.1
Electrical Inductance ±20%	L	mH L-L	64.1	16.0	5.3	95.4	23.9	8.0	127	31.6	10.5
Back EMF Constant @ 25°C±10%	Ke	Vpeak/m/s L-L	166	83.1	48.0	249	124	71.8	332	166	95.7
		Vpeak/in/sec L-L	4.22	2.11	1.22	6.32	3.16	1.82	8.42	4.21	2.43
Force Constant @ 25°C±10%	Kf	N/Arms	203	102	58.7	305	152	87.9	406	203	117
		lbf/Arms	45.7	22.9	13.2	68.5	34.2	19.8	91.3	45.7	26.4
Mechanical Specifications											
Coil Assembly Weight ±15%	Mc	kg	12.5			18.1			23.7		
		lbs	27.6			39.9			52.2		
Magnetic Way Type			MC100			MC150			MC200		
Magnetic Way Weight ±15%	Mw	kg/m	12.7			20.7			26.8		
		lb/in	0.71			1.16			1.50		
Figures of Merit and Additional Data											
Electrical Time Constant	Te	ms	9.0			9.6			10.0		
Max.Theoretical Acceleration (3)	Amax	g's	20.4			21.1			21.5		
Magnetic Attraction	Fa	kN	9.8			14.6			19.7		
		lbf	2205			3271			4433		
Thermal Resistance (4) (coils to external structure)	Rth	°C/Watt	0.073			0.052			0.040		
Max. Allowable Coil Temp. (4)	Tmax	°C	130			130			130		
Min. Flow Rate of Coolant at a Max. Temperature of 25°C		liters/min.	2.8			2.8			2.8		

Notes:

- The motor continuous rated force is measured with the motor coils achieving the motor maximum allowable temperature Tmax.
- Alternate windings can be made available. Please consult the Kollmorgen Customer Support for design options.
- Maximum theoretical acceleration is based on the motors peak force and the motor mass alone. Limitations due to such factors as the additional mass of the load, the bearing type and design, the shock rating of the feedback, the peak current available from the amplifier etc. must be considered to determine the achievable acceleration in each application.
- Please see our application sizing pages in the back of this guide for more details on sizing and thermal considerations.

IC22 Outline Drawings

IC22 OUTLINE DRAWINGS

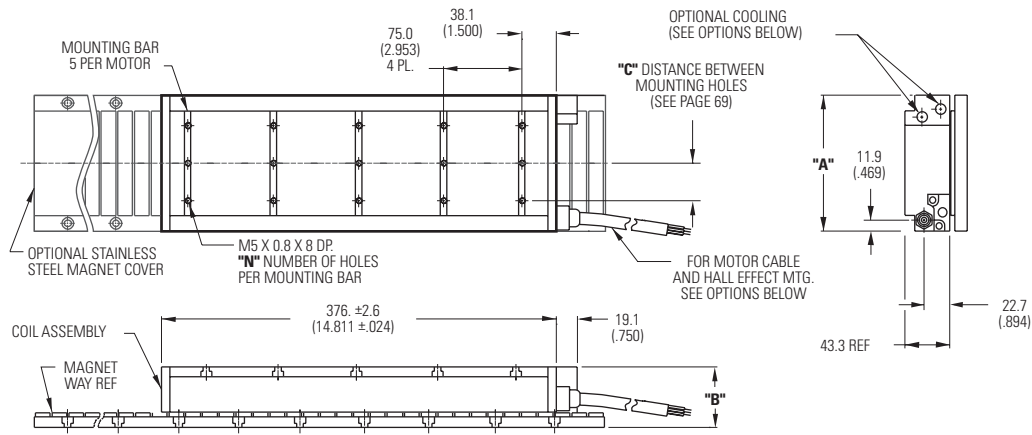

Resultant airgap = 0.9mm (.036) nominal (0.5mm (.020") minimum) when components are set up to dimension "B" in table below. (Please refer to installation manual for more detail)

Motor Coil Type	Coil Width "A"	Cooled	Dim "B"		# Holes "N"
			without Cover	w/ Magnet Cover	
IC22-030	65.0 (2.559) ± 1.0 (.04)	ICXX-030	58.3±0.1 (2.295±.004)	58.6±0.1 (2.307±.004)	2
IC22-050	85.0 (3.346) ± 1.0 (.04)	ICXX-050	58.3±0.1 (2.295±.004)	58.6±0.1 (2.307±.004)	2
IC22-075	110.0 (4.331) ± 1.0 (.04)	ICXX-075	58.3±0.1 (2.295±.004)	58.6±0.1 (2.307±.004)	3
IC22-100	135.0 (5.315) ± 1.0 (.04)	ICXX-100	58.3±0.1 (2.295±.004)	58.6±0.1 (2.307±.004)	3
IC22-150	185.0 (7.283) ± 1.0 (.06)	ICXX-150	60.3±0.1 (2.374±.004)	60.6±0.1 (2.386±.004)	5
IC22-200	235.0 (9.252) ± 1.0 (.06)	ICXX-200	60.3±0.1 (2.374±.004)	60.6±0.1 (2.386±.004)	6

- Notes:
1. Dimensions in mm (inches)
 2. Tolerances unless otherwise specified: no decimal place ±0.8 (0.3) X decimal place ±0.1 (.004) XX decimal place ±0.05 (0.002)

Termination and Hall Effect Options

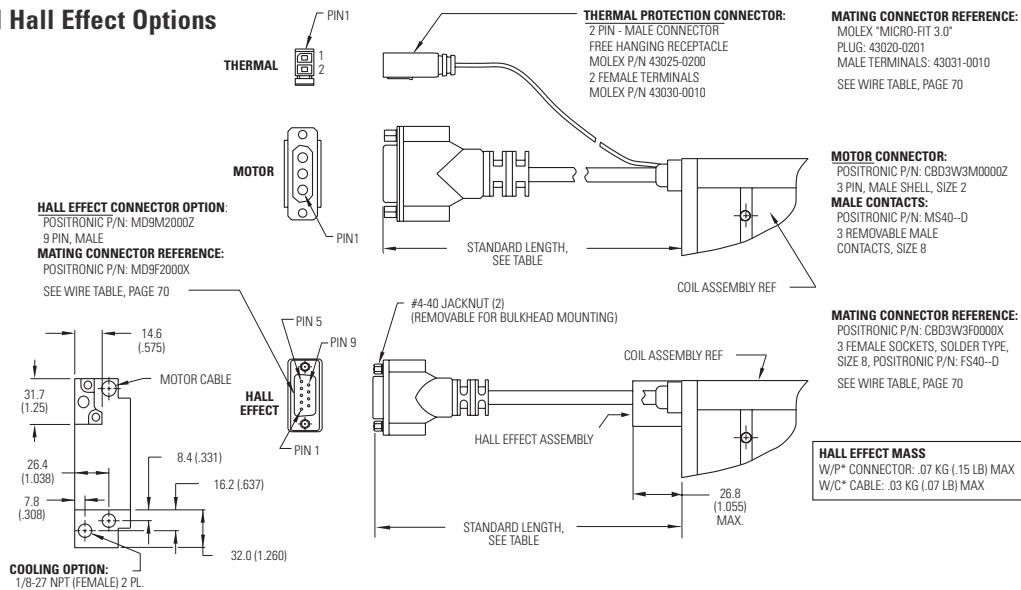

Connector Option			
Connector	Length		
P1	400 (16)	C1	400 (16)
P2	200 (8)	C2	200 (8)
P3	100 (4)	C3	100 (4)
P4	1200 (48)	C4	1200 (48)

Note: Cables exiting motor and hall effects are not dynamic flex cables. For high life flex extension cables, see page 72

Notes

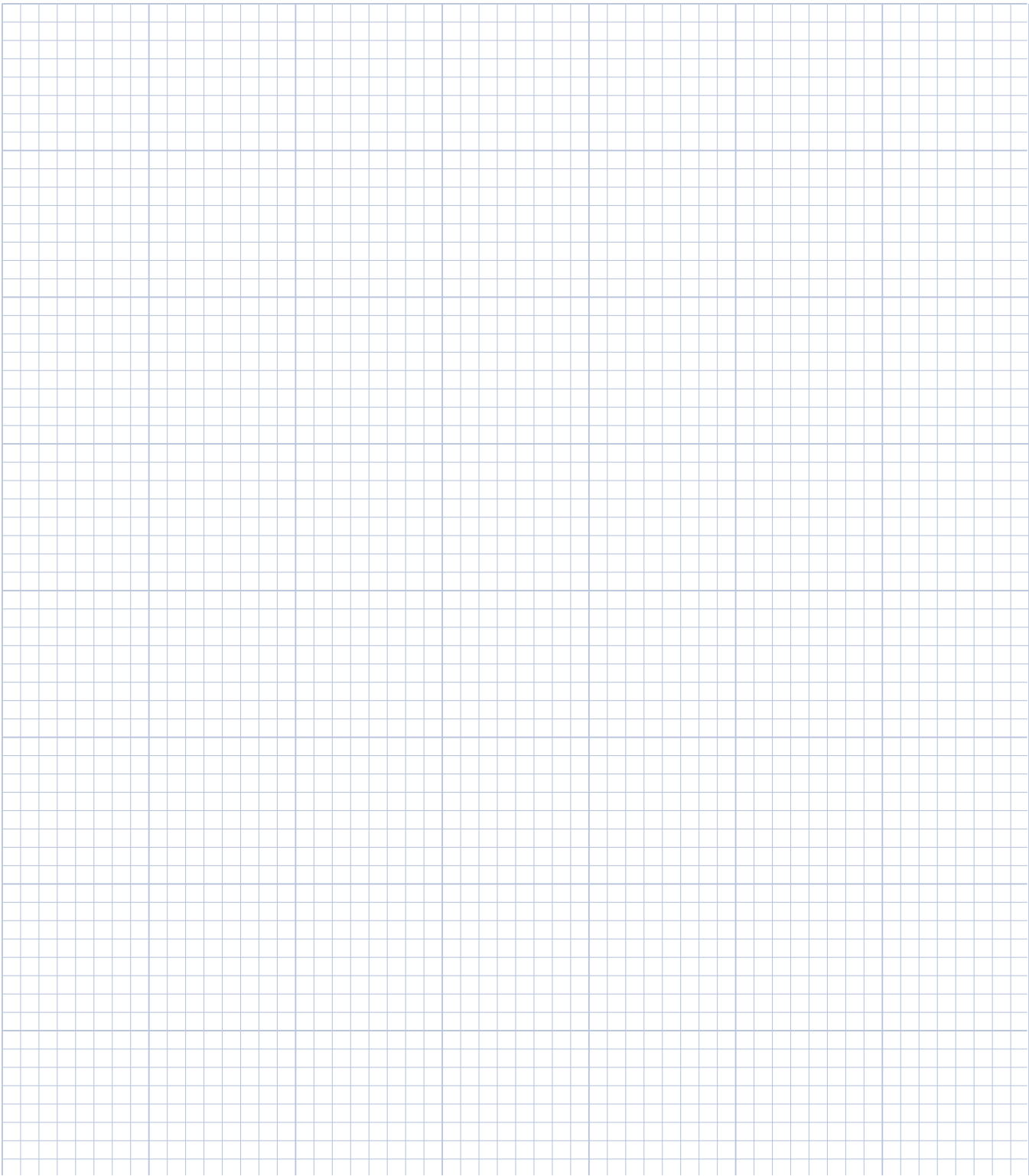

IC33 Performance Data

Ironcore Water-Cooled Motors Series

Rated Performance	Symbol	Units	IC33-030			IC33-050			IC33-075		
Peak Force	Fp	N	945			1575			2365		
		lbf	212			354			532		
Continuous Force @ Tmax (1)	Fc	N	769			1283			1926		
		lbf	173			288			433		
Motor Constant @ 25°C	Km	N/√W	34.5			49.2			64.2		
Electrical Specifications (2)											
		Winding Code	A1	A3	A5	A1	A3	A5	A1	A3	A5
Peak Current	Ip	Arms	13.8	41.4	23.9	13.8	41.4	23.9	13.8	41.4	23.9
Continuous Current @Tmax	Ic	Arms	9.8	29.5	17.0	9.8	29.4	17.0	9.8	29.4	17.0
Electrical Resistance @ 25°C±10%	Rm	Ohms L-L	4.7	0.52	1.6	6.4	0.71	2.1	8.5	0.94	2.8
Electrical Inductance ±20%	L	mH L-L	31.0	3.4	10.3	49.5	5.5	16.5	73.1	8.1	24.4
Back EMF Constant @ 25°C±10%	Ke	Vpeak/m/s L-L	74.5	24.8	43.0	124	41.4	71.7	187	62.2	108
		Vpeak/in/sec L-L	1.89	0.63	1.09	3.16	1.05	1.82	4.74	1.58	2.74
Force Constant @ 25°C±10%	Kf	N/Arms	91.3	30.4	52.7	152	50.7	87.9	229	76.2	132
		lbf/Arms	20.5	6.8	11.9	34.2	11.4	19.8	51.4	17.1	29.7
Mechanical Specifications											
Coil Assembly Weight ±15%	Mc	kg	7.3			10.4			14.4		
		lbs	16.1			22.9			31.7		
Magnetic Way Type			MC030			MC050			MC075		
Magnetic Way Weight ±15%	Mw	kg/m	5.4			7.5			10.1		
		lb/in	0.30			0.42			0.56		
Figures of Merit and Additional Data											
Electrical Time Constant	Te	ms	6.6			7.7			8.6		
Max.Theoretical Acceleration (3)	Amax	g's	15.7			18.4			19.9		
Magnetic Attraction	Fa	kN	4.4			7.4			11.0		
		lbf	991			1652			2480		
Thermal Resistance (4) (coils to external structure)	Rth	°C/Watt	0.11			0.081			0.061		
Max. Allowable Coil Temp. (4)	Tmax	°C	130			130			130		
Min. Flow Rate of Coolant at a Max. Temperature of 25°C		liters/min.	2.8			2.8			2.8		

Notes:

1. The motor continuous rated force is measured with the motor coils achieving the motor maximum allowable temperature Tmax.
2. Alternate windings can be made available. Please consult the Kollmorgen Customer Support for design options.
3. Maximum theoretical acceleration is based on the motors peak force and the motor mass alone. Limitations due to such factors as the additional mass of the load, the bearing type and design, the shock rating of the feedback, the peak current available from the amplifier etc. must be considered to determine the achievable acceleration in each application.
4. Please see our application sizing pages in the back of this guide for more details on sizing and thermal considerations.

Rated Performance	Symbol	Units	IC33-100			IC33-150			IC33-200		
Peak Force	Fp	N	3152			4724			6306		
		lbf	709			1063			1418		
Continuous Force @ Tmax (1)	Fc	N	2593			3849			5135		
		lbf	583			865			1154		
Motor Constant @ 25°C	Km	N/√W	76.5			96.9			114		
Max. Cont. Power Dissipation	Pc	W	2188			3000			3889		
Electrical Specifications (2)											
		Winding Code	A1	A3	A5	A1	A3	A5	A1	A3	A5
Peak Current	Ip	Arms	13.8	41.4	23.9	13.8	41.4	23.9	13.8	41.4	23.9
Continuous Current @Tmax	Ic	Arms	9.9	29.7	17.1	9.8	29.3	16.9	9.8	29.5	17.0
Electrical Resistance @ 25°C±10%	Rm	Ohms L-L	10.6	1.2	3.5	14.9	1.7	5.0	19.1	2.1	6.4
Electrical Inductance ±20%	L	mH L-L	96.2	10.7	32.1	143	15.9	47.7	190	21.1	63.3
Back EMF Constant @ 25°C±10%	Ke	Vpeak/m/s L-L	249	82.9	144	373	124	215	497	166	287
		Vpeak/in/sec L-L	6.32	2.11	3.65	9.47	3.16	5.47	12.6	4.21	7.30
Force Constant @ 25°C±10%	Kf	N/Arms	304	102	176	457	152	264	609	203	352
		lbf/Arms	68.5	22.8	39.5	103	34.2	59.3	137	45.7	79.1
Mechanical Specifications											
Coil Assembly Weight ±15%	Mc	kg	18.9			27.3			35.7		
		lbs	41.7			60.2			78.7		
Magnetic Way Type			MC100			MC150			MC200		
Magnetic Way Weight ±15%	Mw	kg/m	12.7			20.7			26.8		
		lb/in	0.71			1.16			1.50		
Figures of Merit and Additional Data											
Electrical Time Constant	Te	ms	9.1			9.6			9.9		
Max.Theoretical Acceleration (3)	Amax	g's	20.2			21.0			21.4		
Magnetic Attraction	Fa	kN	14.7			22.1			29.4		
		lbf	3305			4957			6609		
Thermal Resistance (4) (coils to external structure)	Rth	°C/Watt	0.048			0.035			0.027		
Max. Allowable Coil Temp. (4)	Tmax	°C	130			130			130		
Min. Flow Rate of Coolant at a Max. Temperature of 25°C		liters/min.	2.8			2.8			2.8		

Notes:

1. The motor continuous rated force is measured with the motor coils achieving the motor maximum allowable temperature Tmax.
2. Alternate windings can be made available. Please consult the Kollmorgen Customer Support for design options.
3. Maximum theoretical acceleration is based on the motors peak force and the motor mass alone. Limitations due to such factors as the additional mass of the load, the bearing type and design, the shock rating of the feedback, the peak current available from the amplifier etc. must be considered to determine the achievable acceleration in each application.
4. Please see our application sizing pages in the back of this guide for more details on sizing and thermal considerations.

IC33 Outline Drawings

Ironcore Water-Cooled Motors Series

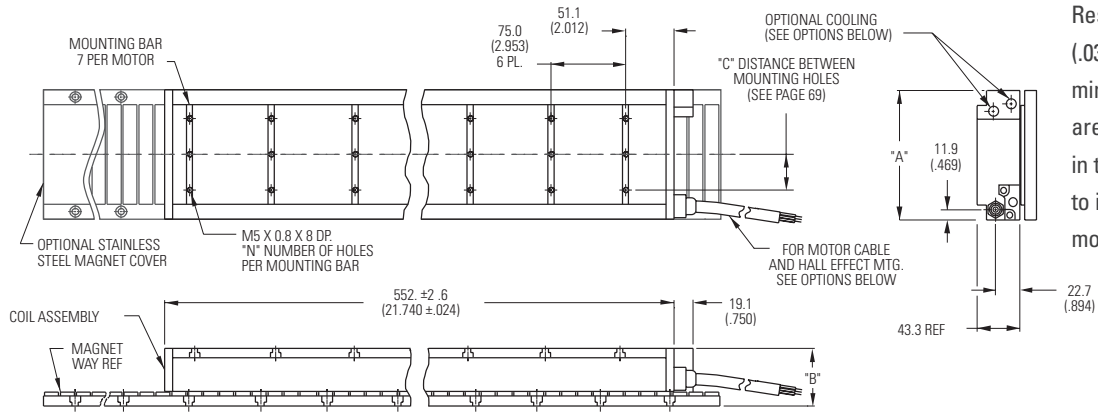

Resultant airgap = 0.9mm (.036) nominal (0.5mm (.020") minimum) when components are set up to dimension "B" in table below. (Please refer to installation manual for more detail)

Motor Coil Type	Coil Width	Cooled	Dim "B"		# Holes "N"
	"A"		without Cover	w/ Magnet Cover	
IC33-030	65.0 (2.559) ± 1.0 (.04)	ICXX-030	58.3±0.1 (2.295±.004)	58.6±0.1 (2.307±.004)	2
IC33-050	85.0 (3.346) ± 1.0 (.04)	ICXX-050	58.3±0.1 (2.295±.004)	58.6±0.1 (2.307±.004)	2
IC33-075	110.0 (4.331) ± 1.0 (.04)	ICXX-075	58.3±0.1 (2.295±.004)	58.6±0.1 (2.307±.004)	3
IC33-100	135.0 (5.315) ± 1.0 (.04)	ICXX-100	58.3±0.1 (2.295±.004)	58.6±0.1 (2.307±.004)	3
IC33-150	185.0 (7.283) ± 1.0 (.06)	ICXX-150	60.3±0.1 (2.374±.004)	60.6±0.1 (2.386±.004)	5
IC33-200	235.0 (9.252) ± 1.0 (.06)	ICXX-200	60.3±0.1 (2.374±.004)	60.6±0.1 (2.386±.004)	6

- Notes:
1. Dimensions in mm (inches)
 2. Tolerances unless otherwise specified: no decimal place ±0.8 (0.3) X decimal place ±0.1 (.004) XX decimal place ±0.05 (0.002)

Termination and Hall Effect Options

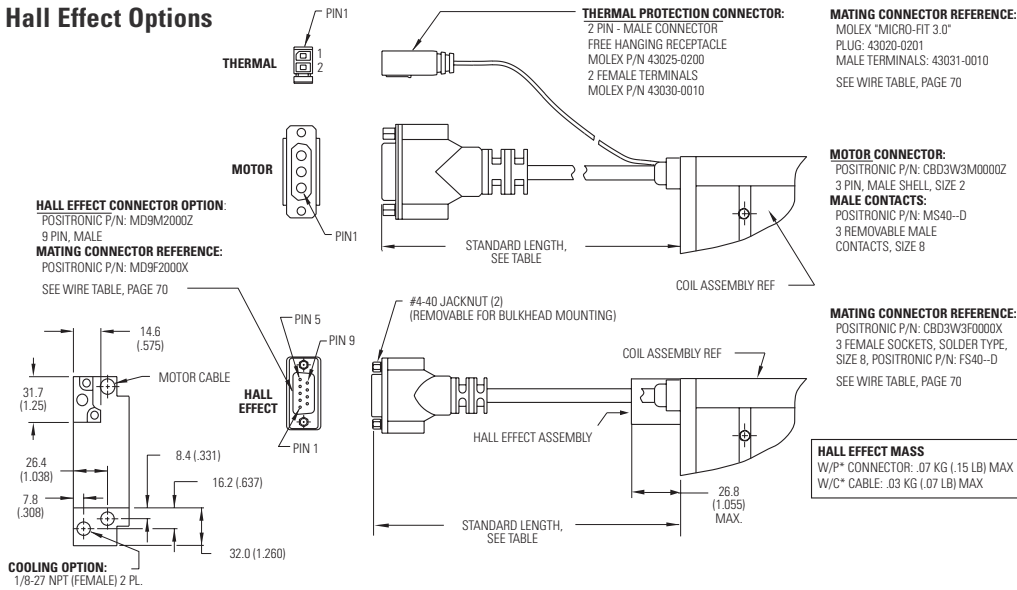

HALL EFFECT MASS
W/P* CONNECTOR: .07 KG (.15 LB) MAX
W/C* CABLE: .03 KG (.07 LB) MAX

Connector Option			
Connector	Length		
P1	400 (16)	C1	400 (16)
P2	200 (8)	C2	200 (8)
P3	100 (4)	C3	100 (4)
P4	1200 (48)	C4	1200 (48)

Note:
Cables exiting motor and hall effects are not dynamic flex cables. For high life flex extension cables, see page 72

Notes

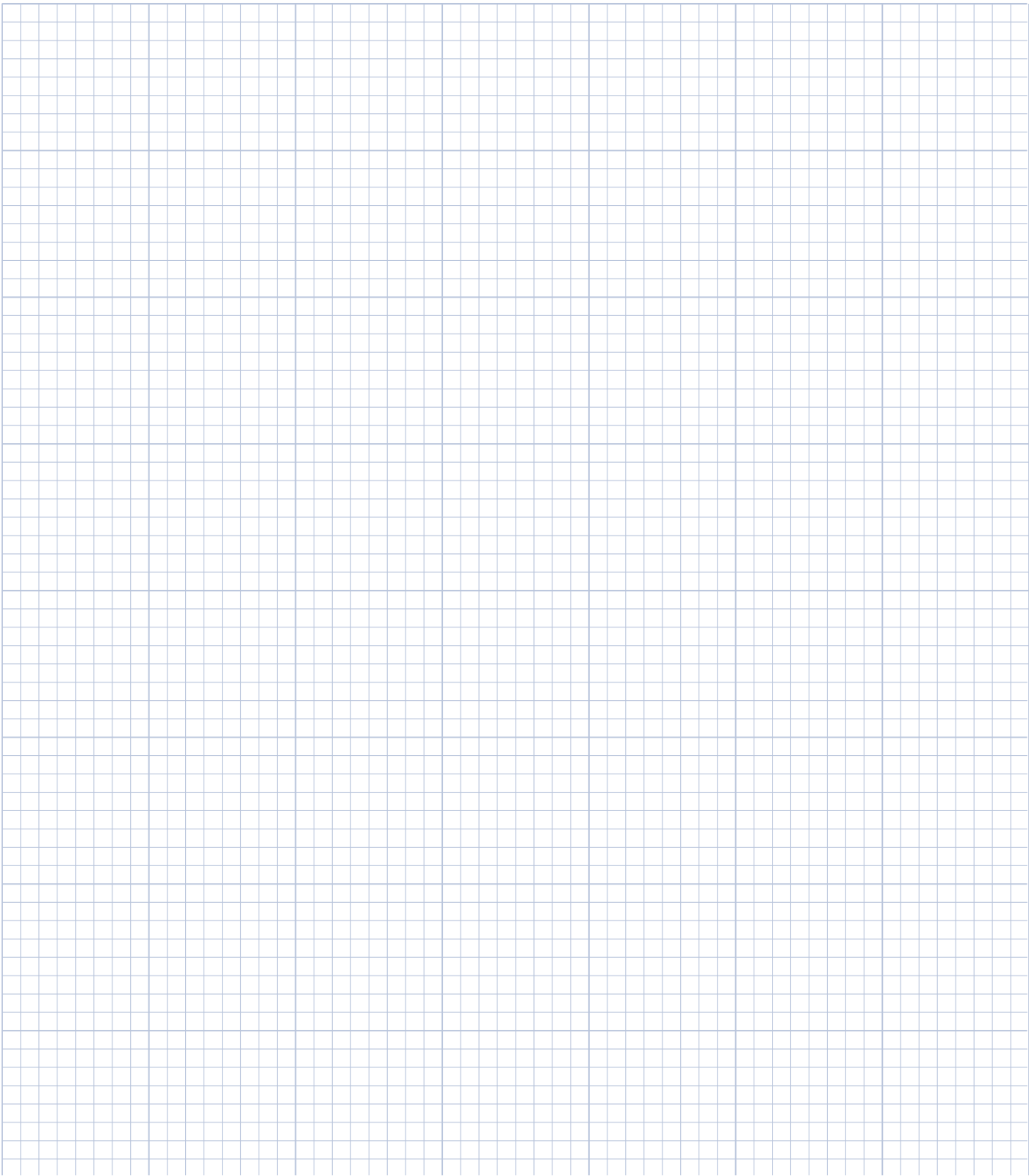

IC44 Performance Data

Ironcore Water-Cooled Motors Series

Rated Performance	Symbol	Units	IC44-030			IC44-050			IC44-075		
Peak Force	Fp	N	1260			2101			3154		
		lbf	283			472			709		
Continuous Force @ Tmax (1)	Fc	N	1036			1711			2568		
		lbf	233			385			577		
Motor Constant @ 25°C	Km	N/√W	39.9			56.8			74.0		
Electrical Specifications (2)											
		Winding Code	A1	A2	A3	A1	A2	A3	A1	A2	A3
Peak Current	Ip	Arms	13.8	27.6	55.2	13.8	27.6	55.2	13.8	27.6	55.2
Continuous Current @Tmax	Ic	Arms	9.9	19.7	39.5	9.8	19.6	39.1	9.8	19.5	39.1
Electrical Resistance @ 25°C±10%	Rm	Ohms L-L	6.2	1.6	0.39	8.5	2.1	0.53	11.3	2.8	0.71
Electrical Inductance ±20%	L	mH L-L	41.3	10.3	2.6	66.1	16.5	4.1	97.3	24.3	6.1
Back EMF Constant @ 25°C±10%	Ke	Vpeak/m/s L-L	99.4	49.7	24.8	166	82.9	41.4	249	124	62.2
		Vpeak/in/sec L-L	2.52	1.26	0.63	4.21	2.11	1.05	6.32	3.16	1.58
Force Constant @ 25°C±10%	Kf	N/Arms	122	60.9	30.4	203	102	50.8	305	152	76.2
		lbf/Arms	27.4	13.7	6.8	45.6	22.8	11.4	68.5	34.2	17.1
Mechanical Specifications											
Coil Assembly Weight ±15%	Mc	kg	9.6			13.9			19.2		
		lbs	21.2			30.6			42.3		
Magnetic Way Type			MC030			MC050			MC075		
Magnetic Way Weight ±15%	Mw	kg/m	5.4			7.5			10.1		
		lb/in	0.30			0.42			0.56		
Figures of Merit and Additional Data											
Electrical Time Constant	Te	ms	6.7			7.8			8.6		
Max.Theoretical Acceleration (3)	Amax	g's	15.9			18.3			19.9		
Magnetic Attraction	Fa	kN	5.9			9.8			14.7		
		lbf	1322			2203			3305		
Thermal Resistance (4) (coils to external structure)	Rth	°C/Watt	0.082			0.061			0.046		
Max. Allowable Coil Temp. (4)	Tmax	°C	130			130			130		
Min. Flow Rate of Coolant at a Max. Temperature of 25°C		liters/min.	2.8			2.8			2.8		

Notes:

1. The motor continuous rated force is measured with the motor coils achieving the motor maximum allowable temperature Tmax.
2. Alternate windings can be made available. Please consult the Kollmorgen Customer Support for design options.
3. Maximum theoretical acceleration is based on the motors peak force and the motor mass alone. Limitations due to such factors as the additional mass of the load, the bearing type and design, the shock rating of the feedback, the peak current available from the amplifier etc. must be considered to determine the achievable acceleration in each application.
4. Please see our application sizing pages in the back of this guide for more details on sizing and thermal considerations.

Rated Performance	Symbol	Units	IC44-100			IC44-150			IC44-200		
Peak Force	Fp	N	4202			6303			8407		
		lbf	945			1417			1890		
Continuous Force @ Tmax (1)	Fc	N	3457			5133			6916		
		lbf	777			1154			1555		
Motor Constant @ 25°C	Km	N/√W	88.3			112			132		
Electrical Specifications (2)											
		Winding Code	A1	A2	A3	A1	A2	A3	A1	A2	A3
Peak Current	Ip	Arms	13.8	27.5	55.1	13.8	27.6	55.3	13.8	27.6	55.2
Continuous Current @Tmax	Ic	Arms	9.9	19.8	39.5	9.8	19.6	39.2	9.9	19.8	39.6
Electrical Resistance @ 25°C±10%	Rm	Ohms L-L	14.1	3.5	0.88	19.8	5.0	1.2	25.5	6.4	1.6
Electrical Inductance ±20%	L	mH L-L	128	32.1	8.0	191	47.7	11.9	253	63.3	15.8
Back EMF Constant @ 25°C±10%	Ke	Vpeak/m/s L-L	331	166	82.9	497	249	124	663	332	166
		Vpeak/in/sec L-L	8.42	4.21	2.11	12.6	6.32	3.16	16.8	8.42	4.21
Force Constant @ 25°C±10%	Kf	N/Arms	406	203	102	609	305	152	812	406	203
		lbf/Arms	91.3	45.6	22.8	137	68.5	34.2	183	91.3	45.7
Mechanical Specifications											
Coil Assembly Weight ±15%	Mc	kg	25.0			36.2			47.4		
		lbs	55.1			79.8			104		
Magnetic Way Type			MC100			MC150			MC200		
Magnetic Way Weight ±15%	Mw	kg/m	12.7			20.7			26.8		
		lb/in	0.71			1.16			1.50		
Figures of Merit and Additional Data											
Electrical Time Constant	Te	ms	9.1			9.6			9.9		
Max.Theoretical Acceleration (3)	Amax	g's	20.4			21.1			21.5		
Magnetic Attraction	Fa	kN	19.6			29.4			39.4		
		lbf	4406			6609			8855		
Thermal Resistance (4) (coils to external structure)	Rth	°C/Watt	0.036			0.026			0.020		
Max. Allowable Coil Temp. (4)	Tmax	°C	130			130			130		
Min. Flow Rate of Coolant at a Max. Temperature of 25°C		liters/min.	2.8			2.8			2.8		

Notes:

1. The motor continuous rated force is measured with the motor coils achieving the motor maximum allowable temperature Tmax.
2. Alternate windings can be made available. Please consult the Kollmorgen Customer Support for design options.
3. Maximum theoretical acceleration is based on the motors peak force and the motor mass alone. Limitations due to such factors as the additional mass of the load, the bearing type and design, the shock rating of the feedback, the peak current available from the amplifier etc. must be considered to determine the achievable acceleration in each application.
4. Please see our application sizing pages in the back of this guide for more details on sizing and thermal considerations.

IC44 Outline Drawings

IC44 OUTLINE DRAWINGS

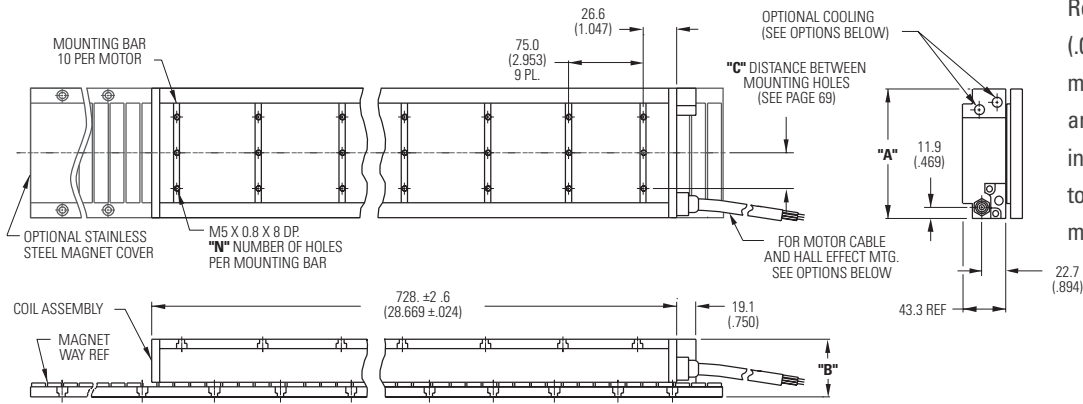

Resultant airgap = 0.9mm (.036) nominal (0.5mm (.020") minimum) when components are set up to dimension "B" in table below. (Please refer to installation manual for more detail)

Motor Coil Type	Coil Width "A"	Cooled	Dim "B"		# Holes "N"
			without Cover	w/ Magnet Cover	
IC44-030	65.0 (2.559) ± 1.0 (.04)	ICXX-030	58.3±0.1 (2.295±.004)	58.6±0.1 (2.307±.004)	2
IC44-050	85.0 (3.346) ± 1.0 (.04)	ICXX-050	58.3±0.1 (2.295±.004)	58.6±0.1 (2.307±.004)	2
IC44-075	110.0 (4.331) ± 1.0 (.04)	ICXX-075	58.3±0.1 (2.295±.004)	58.6±0.1 (2.307±.004)	3
IC44-100	135.0 (5.315) ± 1.0 (.04)	ICXX-100	58.3±0.1 (2.295±.004)	58.6±0.1 (2.307±.004)	3
IC44-150	185.0 (7.283) ± 1.0 (.06)	ICXX-150	60.3±0.1 (2.374±.004)	60.6±0.1 (2.386±.004)	5
IC44-200	235.0 (9.252) ± 1.0 (.06)	ICXX-200	60.3±0.1 (2.374±.004)	60.6±0.1 (2.386±.004)	6

- Notes:
1. Dimensions in mm (inches)
 2. Tolerances unless otherwise specified: no decimal place ±0.8 (0.3) X decimal place ±0.1 (.004) XX decimal place ±0.05 (0.002)

Termination and Hall Effect Options

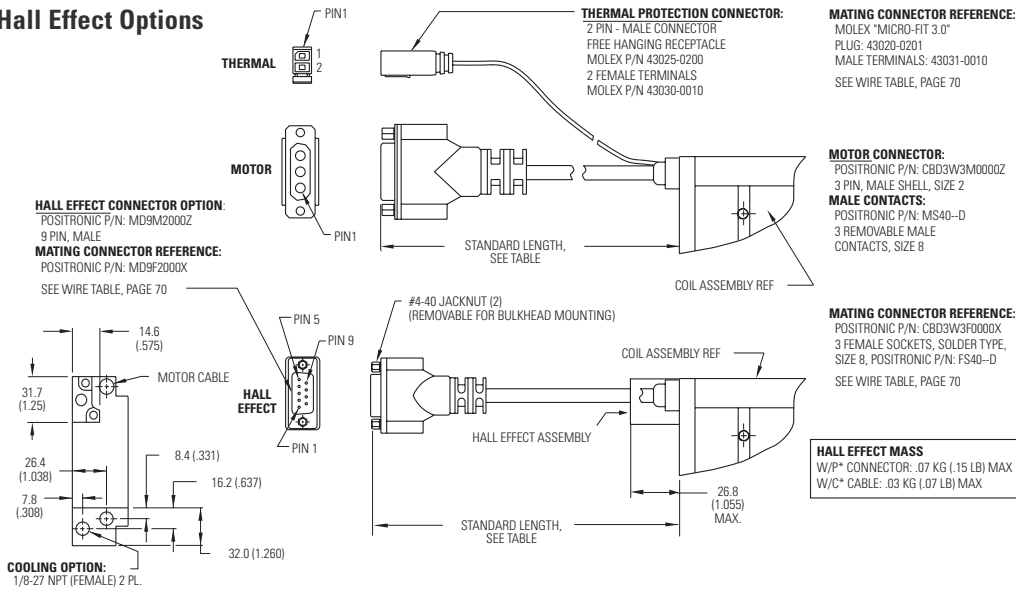

Connector Option			
Connector	Length		
P1	400 (16)	C1	400 (16)
P2	200 (8)	C2	200 (8)
P3	100 (4)	C3	100 (4)
P4	1200 (48)	C4	1200 (48)

Note:
Cables exiting motor and hall effects are not dynamic flex cables. For high life flex extension cables, see page 72

HALL EFFECT MASS
W/P* CONNECTOR: .07 KG (.15 LB) MAX
W/C* CABLE: .03 KG (.07 LB) MAX

Notes

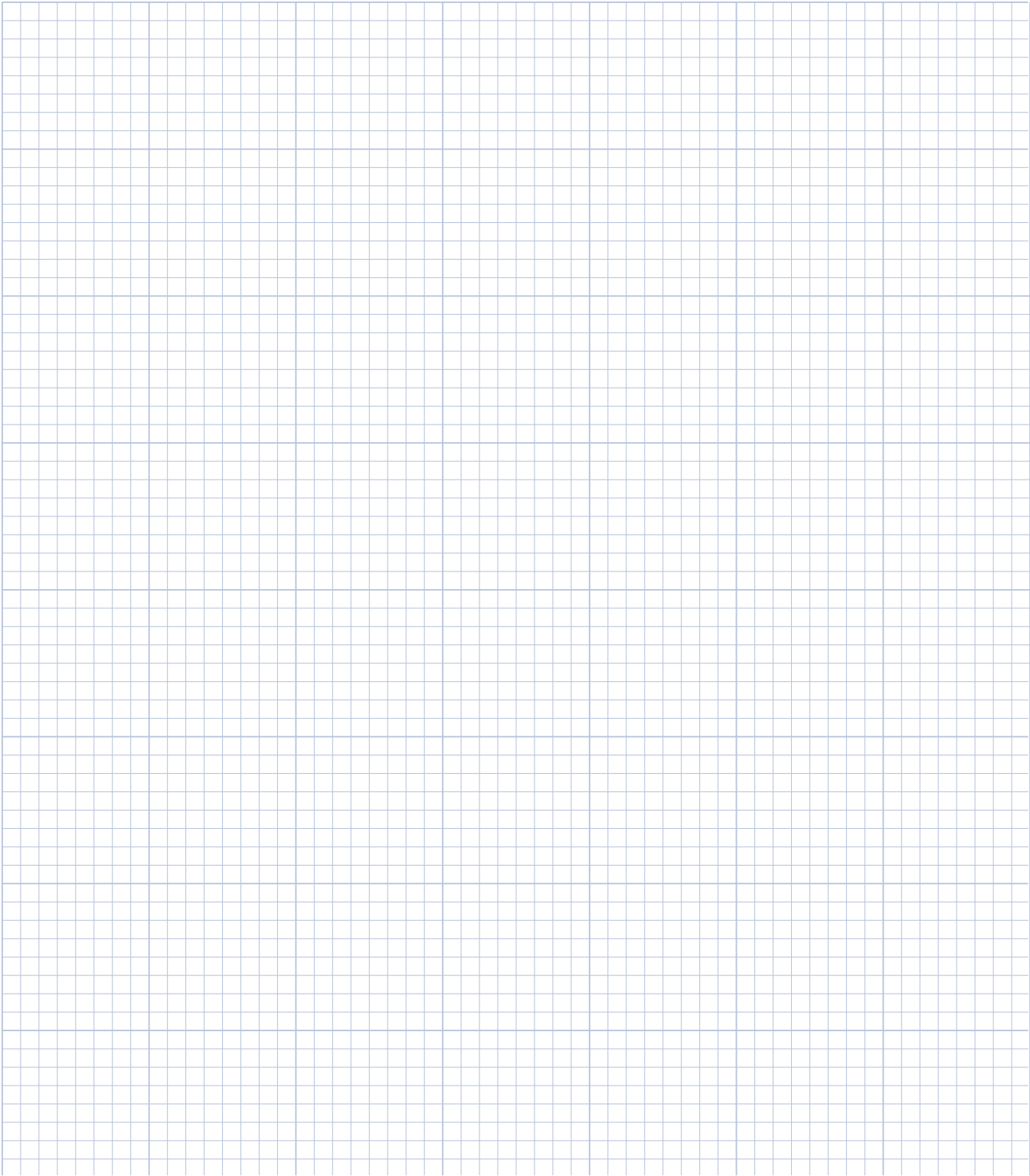

Ironcore Magnet Ways

MCxxx-0064

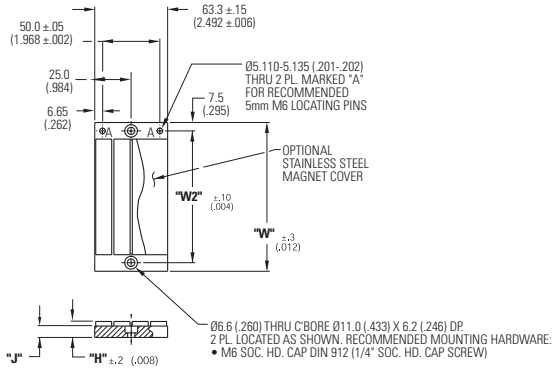

Magnet assemblies are modular and can be installed in multiples of same or alternate lengths. Standard lengths are shown below.

Magnetic Way Type	Assembly Width "W"	Mounting Hole Width "W2"	"J"	"H" With Cover	"H" Without Cover
MC030-0064	60.0 (2.362)	45.0 (1.772)	10.0 (.394)	14.4 (.556)	14.1 (.555)
MC050-0064	80.0 (3.150)	65.0 (2.560)	10.0 (.394)	14.4 (.556)	14.1 (.555)
MC075-0064	105.0 (4.134)	90.0 (3.544)	10.0 (.394)	14.4 (.556)	14.1 (.555)
MC100-0064	130.0 (5.118)	115.0 (4.528)	10.0 (.394)	14.4 (.556)	14.1 (.555)
MC150-0064	180.0 (7.087)	165.0 (6.496)	12.0 (.472)	16.4 (.645)	16.1 (.634)
MC200-0064	230.0 (9.055)	215.0 (8.464)	12.0 (.472)	16.4 (.645)	16.1 (.634)

Dimensions in mm (in)

MCxxx-0128

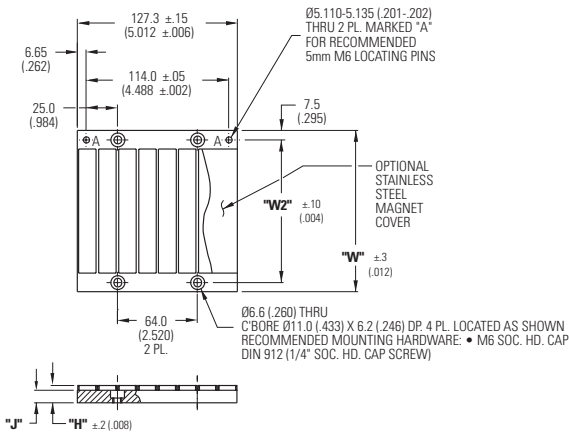

Magnetic Way Type	Assembly Width "W"	Mounting Hole Width "W2"	"J"	"H" With Cover	"H" Without Cover
MC030-0128	60.0 (2.362)	45.0 (1.772)	10.0 (.394)	14.4 (.556)	14.1 (.555)
MC050-0128	80.0 (3.150)	65.0 (2.560)	10.0 (.394)	14.4 (.556)	14.1 (.555)
MC075-0128	105.0 (4.134)	90.0 (3.544)	10.0 (.394)	14.4 (.556)	14.1 (.555)
MC100-0128	130.0 (5.118)	115.0 (4.528)	10.0 (.394)	14.4 (.556)	14.1 (.555)
MC150-0128	180.0 (7.087)	165.0 (6.496)	12.0 (.472)	16.4 (.645)	16.1 (.634)
MC200-0128	230.0 (9.055)	215.0 (8.464)	12.0 (.472)	16.4 (.645)	16.1 (.634)

Dimensions in mm (in)

MCxxx-0256

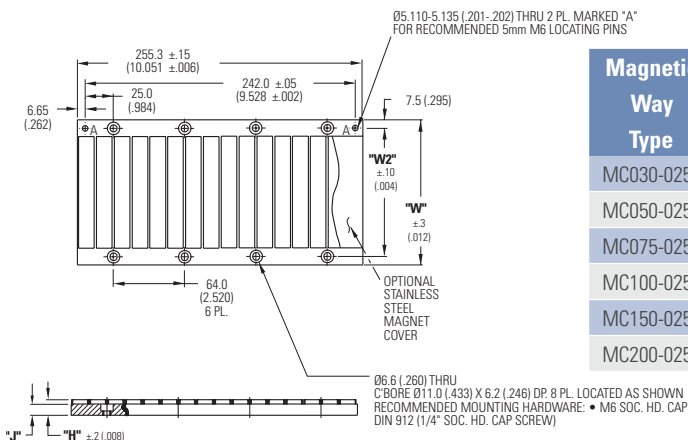

Magnetic Way Type	Assembly Width "W"	Mounting Hole Width "W2"	"J"	"H" With Cover	"H" Without Cover
MC030-0256	60.0 (2.362)	45.0 (1.772)	10.0 (.394)	14.4 (.556)	14.1 (.555)
MC050-0256	80.0 (3.150)	65.0 (2.560)	10.0 (.394)	14.4 (.556)	14.1 (.555)
MC075-0256	105.0 (4.134)	90.0 (3.544)	10.0 (.394)	14.4 (.556)	14.1 (.555)
MC100-0256	130.0 (5.118)	115.0 (4.528)	10.0 (.394)	14.4 (.556)	14.1 (.555)
MC150-0256	180.0 (7.087)	165.0 (6.496)	12.0 (.472)	16.4 (.645)	16.1 (.634)
MC200-0256	230.0 (9.055)	215.0 (8.464)	12.0 (.472)	16.4 (.645)	16.1 (.634)

Dimensions in mm (in)

MCxxx-0512

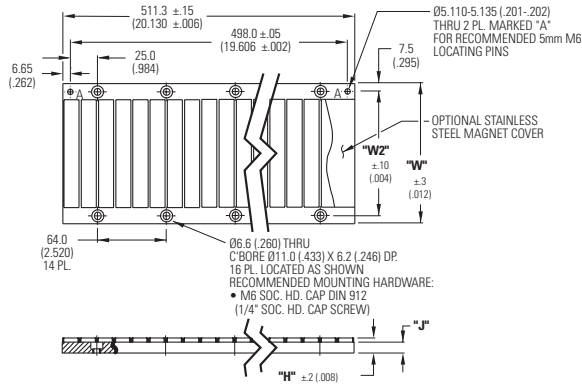

Magnetic Way Type	Assembly Width "W"	Mounting Hole Width "W2"	"J"	"H" With Cover	"H" Without Cover
MC030-0512	60.0 (2.362)	45.0 (1.772)	10.0 (.394)	14.4 (.556)	14.1 (.555)
MC050-0512	80.0 (3.150)	65.0 (2.560)	10.0 (.394)	14.4 (.556)	14.1 (.555)
MC075-0512	105.0 (4.134)	90.0 (3.544)	10.0 (.394)	14.4 (.556)	14.1 (.555)
MC100-0512	130.0 (5.118)	115.0 (4.528)	10.0 (.394)	14.4 (.556)	14.1 (.555)
MC150-0512	180.0 (7.087)	165.0 (6.496)	12.0 (.472)	16.4 (.645)	16.1 (.634)
MC200-0512	230.0 (9.055)	215.0 (8.464)	12.0 (.472)	16.4 (.645)	16.1 (.634)

Dimensions in mm (in)

Typical Installation of Multiple Ironcore Magnet Assemblies

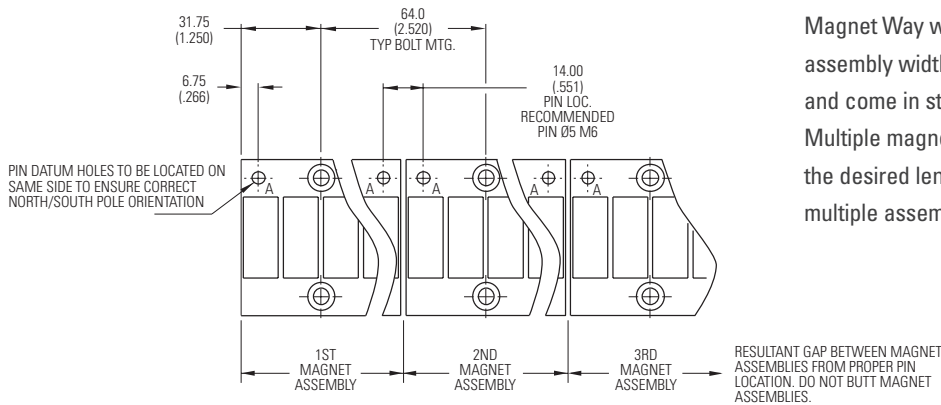

Magnet Way widths correspond to the mating coil assembly width. Magnet Way assemblies are modular and come in standard lengths: 64, 128, 256, 512 mm. Multiple magnet assemblies can be installed to obtain the desired length. Shown below is the method to mount multiple assemblies.

Typical Mounting Bar Lengths & Mounting Holes Tabulation

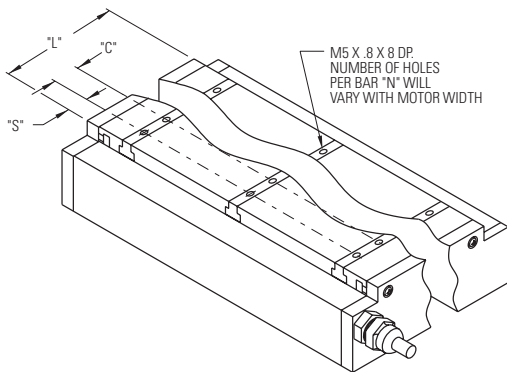

Magnetic Coil Type	Number of Holes "N"	Spacing Between Holes "C"	Mounting Bar Length "L"	"S"
ICXX-030	2	16.0 (0.630)	30 (1.18)	7.0 (.276)
ICXX-050	2	36.0 (1.417)	50 (1.97)	7.0 (.276)
ICXX-075	3	32.0 (1.260)	75 (2.95)	5.5 (.217)
ICXX-100	3	36.0 (1.417)	100 (3.94)	14.0 (.551)
ICXX-150	5	32.0 (1.260)	150 (5.91)	11.0 (.433)
ICXX-200	6	36.0 (1.417)	200 (7.87)	10.0 (.394)

Dimensions in mm (in)

Wiring and Output

Motor Wire Table SEE TABLE BELOW FOR AWG DIA			Hall Effect Wire Table 26 AWG 6.0 DIA (.24")			Thermal Protection Wire Table Thermistor 26 AWG 3.8 (.15")		
Pin Number	Color or Wire No.	Function	Pin Number	Color	Function	Pin	Color	Transition Point
1	Red	ØA	1	Gray	+5 VDC	1	Black/White	120°C (IC/ICD)
2	White	ØB	2	Green	S1			90°C (IL)
3	Black	ØC	3	Yellow	S2	2	Black/White	120°C (IC/ICD)
Connector Shell	Grn/Yel	GND	4	Brown	S3			90°C (IL)
Connector Shell	Violet	Shield	5	White	Return	see note 2		
			Shell	Shield	Shield			

Notes:

1. Ground and shield connection at shell: first make/last break
2. TIC-X extender cable is shielded

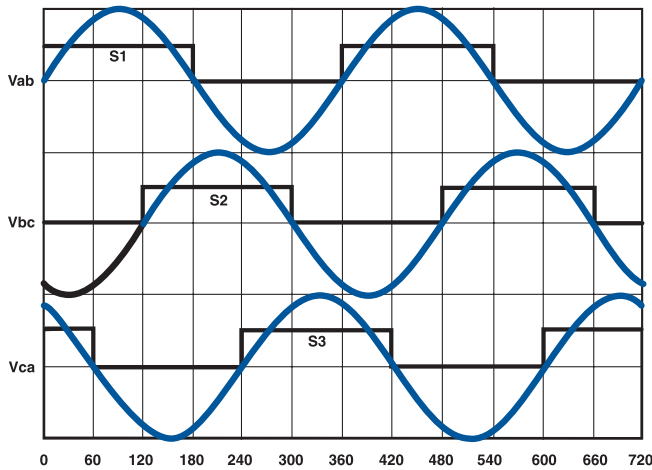

Motor BEMF phases A,B,C relative to Hall effect devices S1,S2,S3 with coil travel direction towards the motor output cable assembly exit as shown below.

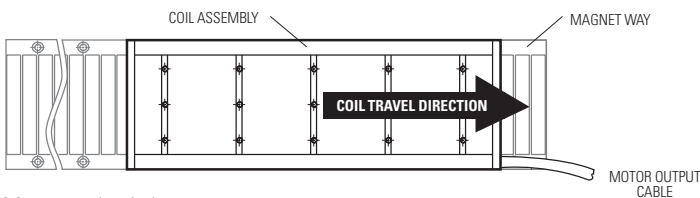

Magnet pole pitch:

Both Ironcore (IC) and Ironless (IL) feature the same pole pitch, which is 32 mm (360 electrical degrees).

Note:

1. The diagram above refers to both Ironless and Ironcore motors

IL WIRE TABLE		
WINDING CODE	AWG	APPROX. CBL. DIA.
ALL (A1,A2,A3,A4)	18	5.6mm (.22 IN)

ICD WIRE TABLE		
WINDING CODE	AWG	APPROX. CBL. DIA.
ALL (A1 - A4)	22	5.1mm (.20 IN)

IC WIRE TABLE NON-COOLED		
WINDING CODE	AWG	APPROX. CBL. DIA.
A1	18	5.6mm (.22 IN)
A2	18	5.8mm (.22 IN)
A3	14	8.9mm (.27 IN)
A5	18	5.8mm (.22 IN)
A6	14	6.9mm (.27 IN)
A7	10	7.9mm (.31 IN)

IC WIRE TABLE COOLED (AC)		
WINDING CODE	AWG	APPROX. CBL. DIA.
A1	18	5.6mm (.22 IN)
A2	14	8.9mm (.27 IN)
A3	10	7.9mm (.31 IN)
A5	14	8.9mm (.27 IN)
A6	12	7.9mm (.31 IN)

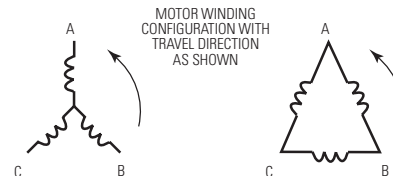

To size a Linear Motor, you will need to:

1. Define a Move Profile
2. Define the Load
3. Size the Motor and the Amplifier

From the move profile, we can calculate the maximum speed and the maximum acceleration/deceleration. From the load we can calculate all of the forces at constant speed and using the move profile all the dynamic forces during acceleration and deceleration. Once a motor is selected, the weight of the moving parts of the motor are added to the moving weight to calculate a total Peak Force and a total RMS force. The motor should be able to deliver the peak force and the calculated RMS force should be higher than the continuous force to ensure a known safety margin. The coil temperature rise can also be calculated to ensure that it is lower than the intended maximum temperature rise.

The maximum bus voltage and continuous and peak current can also be calculated and compared to the selected amplifier to be sure the calculated performances can be achieved.

Max Speed: $V_m = 2 \cdot S_m / (t_a + t_d + 2 \cdot t_r)$
 $V_m = 2 \cdot 0.1 / (100E-3)$
 $= 2 \text{ meter/sec}$

Max Acceleration/Deceleration

Acceleration
 $A_m = V_m / t_a$
 $A_m = 2 / 50E-3$
 $= 40 \text{ meter/sec}^2$
 $A_m \text{ "g"} = A_m / 9.81$
 $a (g) = 40 / 9.81$
 $= 4.08 \text{ g}$

Deceleration
 $D_m = V_m / t_d$
 $D_m = 2 / 50E-3$
 $= 40 \text{ meter/sec}^2$
 $D_m \text{ "g"} = D_m / 9.81$
 $d(g) = 40 / 9.81$
 $= 4.08 \text{ g}$

1. Move Profile

Triangular/Trapezoidal

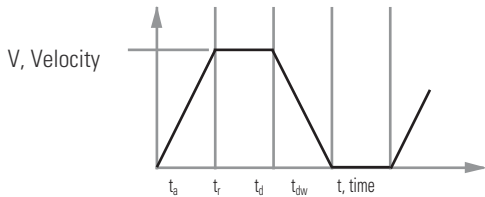

	Units	
	SI	English
S_m - Move displacement	meters	inches
t_a - Acceleration Time	seconds	seconds
t_r - Time run at constant speed	seconds	seconds
t_d - Deceleration Time	seconds	seconds
t_{dw} - Dwell Time	seconds	seconds
V_m - Max Velocity	meter/sec.	inches/sec
A_m - Acceleration	meter/sec ²	inches/sec ²
D_m - Deceleration	meter/sec ²	inches/sec ²

EXAMPLE: Move 0.1 meter in 100 msec assuming $t_a = t_d$ and $t_r = 0$, (assume triangular move)

2. Load

	Units	
	SI	English
F_{ext} - External Force only (Cutting force, etc.)	N	lbf
F_{acc} - Acceleration Force only	N	lbf
F_r - Run Force at constant speed	N	lbf
F_{dec} - Deceleration Force only	N	lbf
F_{am} - Max. Acceleration Force	N	lbf
F_{dm} - Max. Deceleration Force	N	lbf
F_{dw} - Dwell Force	N	lbf
F_{rms} - RMS Force	N	lbf
μ - Coefficient of Friction (bearing support)	-	-
M_l - Load Mass	kg	lbs
M_c - Coil Mass	kg	lbs
M_{cb} - Counterbalance Mass	kg	lbs
F_a - Magnetic Attraction Force	N	lbf
CB - Counterbalance of load in %	-	-
q - Angle of Linear Displacement with horizontal (0°= horizontal, 90° vertical)	degrees	degrees
g - Gravity coefficient	9.81 m/s ²	386 in/s ²
n - Number of motors in parallel	-	-

High Flex Cable Sets

Features

- High Flex cable designed for dynamic, continuous flexing applications
- Cable track compatible
- Molded, high reliability connectors
- Oil resistant PVC jacket
- 105°C / 600V motor cable, 105°C / 300V Hall effect and thermal sensor cable
- CE compliant, fully shielded low impedance cable and connectors
- Fully tested, color coded, shipped with schematics
- Complete cable system for simple and reliable plug-and-play installation

Standard lengths of 1, 3, 6, 9, 12 and 15 meters available. For other lengths, consult Kollmorgen Customer Support.

High Flex Cables for Use with AKD

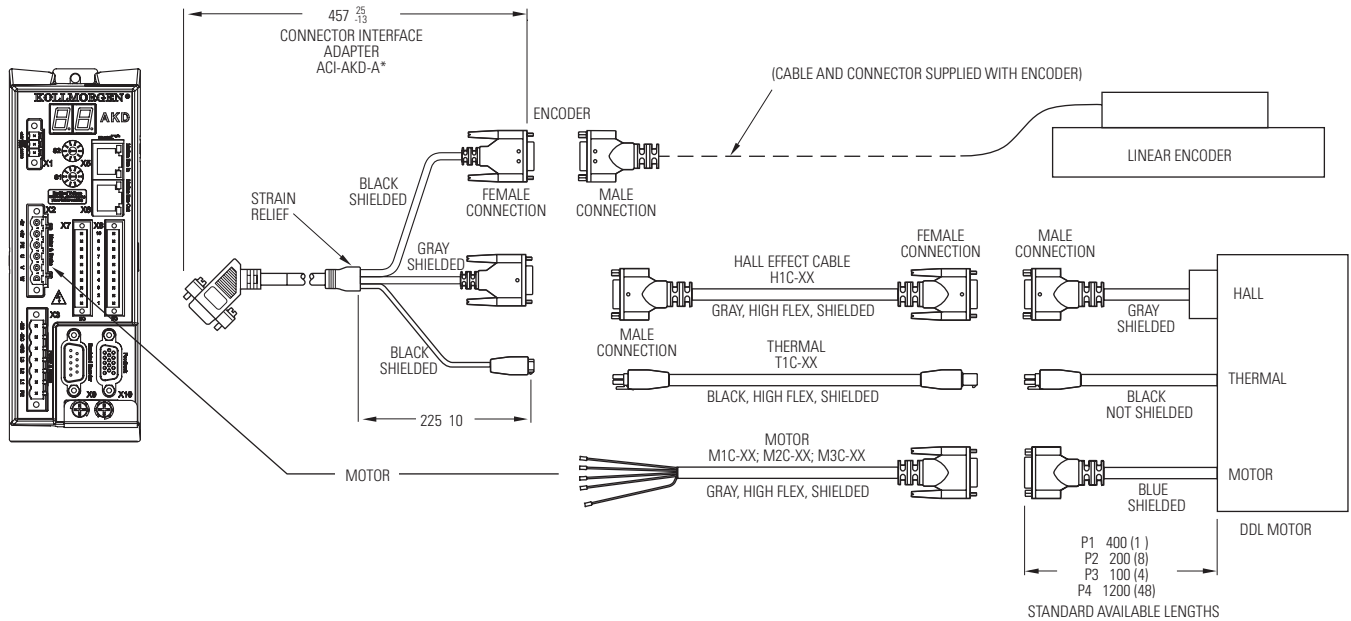

Note: ACI-AKD-A for use with Heidenhain Encoders. ACI-AKD-B for use with Renishaw Encoders.

Dimensions in mm (in)

High Flex Cables for Generic Applications

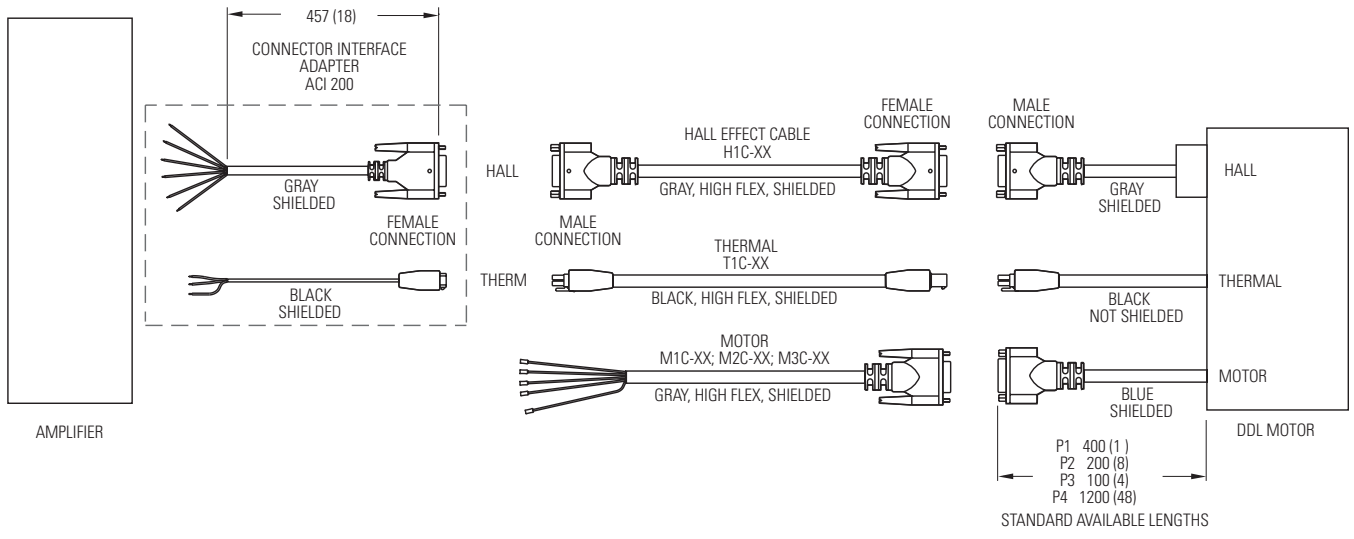

Dimensions in mm (in)

Minimum recommended Dynamic Bend Radius 15x cable diameter

Cable Assembly	AWG	Wire Diameter	Min. Dynamic Radius (15x wire Ø)
M1C	18	11.0mm (.430in)	165mm (6.5in)
M2C	14	12.6mm (.495in)	185mm (7.3in)
M3C	12	14.2mm (.560in)	215mm (8.5in)
T1C	22	6.0mm (.235in)	90mm (3.5in)
H1C	26	6.0mm (.235in)	90mm (3.5in)

Notes:

1. Cables are designed for minimum life cycle of millions of cycles under ideal conditions. Actual field application conditions may or may not produce the cable life described here in.
2. To ensure longest possible cable life under dynamic conditions, cables should be relaxed 24 hours before use by hanging freely at its mid-point. Cable is ready when very little memory is present. Cable should be installed in the 'plane of original flexure.' Cable should be installed with lowest possible mechanical tension. Avoid torsional bending.
3. Minimum recommended dynamic bend radius is 15x largest cable diameter used in cable track; use a large bend radius whenever possible. Clearance between cables and track should be a minimum of 20% of the cable diameter. Use of a clamp or nylon cable tie that creates localized stress within the cable track must be avoided. Minimum distance from the clamping point to the start of the bend radius must be 25x the largest cable diameter used in the track.
4. Cable track manufacturer should be consulted for application assistance. Evellore nos eos quam, consequi ventiist, odis autatur epudae et apist qui bernat oditaes re dolupta tesequo vit eum, occum quibus dolupidus.

Application Sizing

BASIC FORMULAS*:

We assume a general case where we have n motors solidly coupled pushing the load and a possible counterbalance weight M_{cb} (Mostly for vertical displacement).

Example of Coefficient of Friction μ:

Linear bearing w/ balls	0.002 - 0.004
Linear bearing w/ rollers	0.005
Steel on oiled steel	0.06
Steel on dry steel	0.2
Steel on concrete	0.3

Counterbalance Weight:

$$M_{cb} = M_l \cdot CB/100$$

Acceleration Force only:

$$F_{acc} = [(M_l/n) \cdot (1 + CB/100) + M_c] \cdot A_m$$

Run Force at constant speed:

$$F_r = (M_l/n + M_c) \cdot g \cdot \sin(q) + m \cdot \cos(q) - (M_{cb}/n) \cdot g + F_a \cdot \mu + F_{ext}/n$$

Deceleration Force only:

$$F_{dec} = [(M_l/n) \cdot (1 + CB/100) + M_c] \cdot D_m$$

Maximum Acceleration Force:

$$F_{am} = F_{acc} + F_r$$

Maximum Deceleration Force:

$$F_{dm} = F_{dec} - F_r$$

Dwell Force:

$$F_{dw} = (M_l/n + M_c) \cdot g \cdot [\sin(q)] - (M_{cb}/n) \cdot g$$

RMS Force:

$$F_{rms} = \sqrt{\frac{F_{am}^2 \cdot t_a + F_r^2 \cdot t_r + F_{dm}^2 \cdot t_d + F_{dw}^2 \cdot t_{dw}}{t_a + t_r + t_d + t_{dw}}}$$

* All calculations are given in SI units.
For English units use weight in lbs instead of mass • g.

3. Size the Motor and Amplifier

example:

Moving Weight:	M _l = 0.5kg
Number of Motors:	n = 1
Horizontal Move:	q = 0
Counterbalance Force:	M _{cb} = 0
External Force:	F _{ext} = 0
Friction Coefficient:	μ = 0.01

Assume same move as above with a Dwell Time of 50 ms.

Run Force at Constant Speed:	F _r = 0.5 • 9.81 • 0.01 = 0.05 N
Acceleration Force only:	F _a = 0.5 • 40 = 20 N
Deceleration Force only:	F _d = 0.5 • 40 = 20 N
Maximum Accel Force:	F _{am} = 20 + 0.05 = 20.05 N
Maximum Decel Force:	F _{dm} = 20 - 0.05 = 19.95 N
Rms Force:	

$$F_{rms} = \sqrt{\frac{(20.05)^2 \cdot (50E-3) + (19.95)^2 \cdot (50E-3)}{100E-3 + 50E-3}}$$

$$F_{rms} = 16.3 \text{ N}$$

Motor Sizing:

If we select an ironless motor for smoothest possible move we can use Motor IL060-30A1. This motor has a coil mass of 0.21 kg and no attractive force. By adding that weight in equations above, we need an additional force of 0.21 • 40 • 0.01 = 0.084 N. So Peak Force is 20.05 + 0.08 = 28.45 N and RMS force: 23.19 N. This motor will have a safety factor of (38-23.19) • 100/38 = 39%.

Sizing the Amplifier :

	Units	
	SI	English
I _a - Max Acceleration Current	A	A
I _r - Run Current	A	A
I _d - Max Deceleration Current	A	A
I _{dw} - Dwell Current	A	A
I _{rms} - RMS Current	A	A
K _f - Force Constant	N/A	lbf/A
R _m - Motor Electrical Resistance	Ohms L-L	Ohms L-L
K _e - Back EMF Constant	Vpeak/m/s	Vpeak/in/s
V _{bus} - Bus Voltage	VDC	VDC
L - Electrical Inductance	H L-L	H L-L
Max Acceleration Current:	I _a = F _{am} /K _f	
Run Current at constant Speed:	I _r = F _r /K _f	
Max Deceleration Current only:	I _d = F _{dm} /K _f	
Dwell Current:	I _{dw} = F _{dw} /K _f	
RMS Current:	I _{rms} = F _{rms} /K _f	

BUS VOLTAGE:

If we assume a sine wave drive with a phase advance θ (degrees) and full conduction, the minimum bus voltage (see Fig. 1) is:

$$V_{b1} = 2.4 \text{ (Volts)}$$

$$V_{b2} = K_e \cdot V_m$$

$$V_{b3} = 1.225 \cdot R_{m,hot} \times I_{rms}$$

$$V_{b4} = 7.6953 \cdot L \cdot I_{rms} \cdot V_m / \text{Pitch}$$

$$av = \text{ARCTANGENT} (V_{b4}/V_{b3})$$

$$V_{lr} = \sqrt{V_{b3}^2 + V_{b4}^2}$$

$$V_{bre} = V_{b2} + V_{lr} \cdot \text{COS}(av + \theta)$$

$$V_{bim} = V_{lr} \cdot \text{SIN}(av + \theta)$$

$$V_{bus} = V_{b1} + \sqrt{V_{bre}^2 + V_{bim}^2}$$

Note: If there is no Phase advance take $\theta=0^\circ$.

Figure 1:

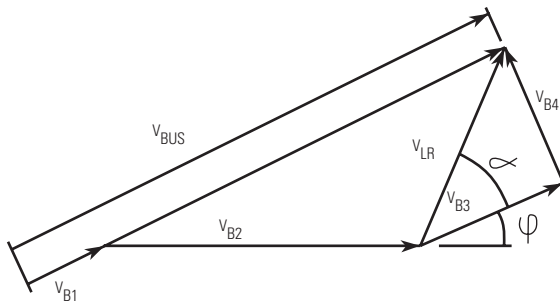

THERMAL CONSIDERATIONS:

	Units	
	SI	English
$\Delta\theta$ - Coil increase of temperature	$^\circ\text{C}$	$^\circ\text{F}$
R_{th} - Thermal Resistance	$^\circ\text{C}/\text{W}$	$^\circ\text{F}/\text{W}$
K_m - Motor Constant	$\text{N}/\sqrt{\text{W}}$	$\text{lbf}/\sqrt{\text{W}}$
P_{out} - Output Power	W	W

Coil Temperature rise

$$\Delta\theta = R_{th} \cdot (F_{rms}/K_m)^2$$

Resistance of Coil hot (copper)

$$R_{m,hot} = \frac{R_{ambient} (234.5 + \theta_{hot})}{(234.5 + \theta_{hot})}$$

Power Losses

$$P_{I_{rms}} = \Delta\theta/R_{th} = \frac{(\theta_{hot} - \theta_{ambient})}{R_{th}}$$

Output Power

$$P_{out(max)} = F_{am} \cdot V_m$$

Example: In above example with:

$$R_{th} = 1.61 \text{ } ^\circ\text{C}/\text{W}$$

$$K_m = 4.7 \text{ N}/\sqrt{\text{W}}$$

Coil Temperature rise: $\Delta\theta = 1.61 \cdot (23.19/4.7)^2 = 39.2 \text{ } ^\circ\text{C}$

Power Losses $PI = 39.2/1.61 = 24.34 \text{ Watts}$

Max output Power $P_{out(max)} = 57 \text{ Watts}$.

The Use of the Motor Constant K_m :

Cognizance of the heat load being generated by the linear motor is an important consideration in the application of any linear motor. Linear motors are direct drive devices, typically mounted very close to the moving load. Therefore, any heat generated by the linear motor needs to be managed to avoid affecting the process or workpiece that the moving load is carrying. The motor constant K_m is a powerful parameter that can be used to determine this heat load.

K_m equals:

$$K_m = \frac{F}{\sqrt{P_c}}$$

where the RMS force F is in Newtons,
the RMS heat load P_c is in watts
and K_m is in units of $\text{N}/\sqrt{\text{W}}$

Application Sizing

The motor constant, K_M , allows us to determine motor performance capabilities such as shown in the following two examples. In the first example, we use K_M to calculate, for a given force, how many watts of generated heat are dissipated by the motor's coil assembly. In the second, we use K_M to determine the maximum RMS force developed by the motor when the dissipated power is limited to some value.

1. An application requires a continuous thrust force of 200 Newtons. The IC11-050 ironcore motor is a good candidate, having a continuous force rating of 276 Newtons and a K_M of 32.0 N/W. Therefore, since resistance rises 1.405 times at 130°C from the ambient value at 25°C, and since resistance is the square root denominator of K_M , we must write our equation as follows,

$$\text{Force} = \frac{K_M}{\sqrt{\text{Factor}}} \sqrt{\text{Power (dissipated)}}$$

$$200 = \frac{32.0}{\sqrt{1.405}} \sqrt{\text{Watts}}$$

Watts = 54.9

This value of watts is the power or heat generated by the motor. It is interesting to note that for the same application, a larger IC11-100 ironcore motor, with a K_M of 49.1 N/ $\sqrt{\text{W}}$, would dissipate only 23.3 watts for the same force, F.

2. The same application requires that no more than 45 watts are to be dissipated by the motor into the surrounding structure and environment. What is the maximum RMS force that the IC11-050 motor may produce while not exceeding this power limit?

$$\text{Maximum RMS Force} = \frac{32.0}{\sqrt{1.405}} \sqrt{45} = 181 \text{ N}$$

Therefore, if the motor delivers no more than 181 N of thrust force on an RMS basis, then this same motor will not dissipate more than 45 watts.

Continuous Force F_c as a Function of Ambient Temperature

In our data sheets the continuous rated force F_c is the RMS force that the motor can supply continuously 100% of the time, assuming the ambient temperature is 25 degrees C and with the coils achieving a maximum temperature of 130 degrees C. At higher (or lower) ambient temperatures, the F_c of the motor must be adjusted by a factor that is determined by the following equation:

$$\text{Factor} = \sqrt{\frac{(130 - \theta_{\text{Amb}})}{105}}$$

where θ_{Amb} = Ambient Temperature

This factor vs. ambient temperature works out as:

5 °C	10	15	20	25	30	35	40	45
1.091	1.069	1.047	1.024	1	0.976	0.951	0.926	0.900

Application Sizing Worksheet

Customer:	Project Name:
Contact:	Axis Name:
Telephone:	Prepared by:
fax:	E-Mail:

Move

Axis Orientation _____	<input type="checkbox"/> horizontal	<input type="checkbox"/> vertical
Typical Move _____	<input type="checkbox"/> mm	<input type="checkbox"/> in
Typical Travel Time _____	<input type="checkbox"/> mm	<input type="checkbox"/> in
Typical Move Time _____	seconds	
Maximum Speed _____	<input type="checkbox"/> meters/sec	<input type="checkbox"/> inches/sec
Minimum Speed _____	<input type="checkbox"/> meters/sec	<input type="checkbox"/> inches/sec
Max. Acceleration _____	<input type="checkbox"/> meters/sec ²	<input type="checkbox"/> inches/sec ² <input type="checkbox"/> g
or Accel/Decel Time _____	seconds	
Dwell Time _____	seconds	
More Profile _____	<input type="checkbox"/> trapezoidal <input type="checkbox"/> triangular	<input type="checkbox"/> S-curve

Loads

Friction Coefficient _____		
Max Load Mass _____	<input type="checkbox"/> kg	<input type="checkbox"/> lb
Thrust Force _____	<input type="checkbox"/> N	<input type="checkbox"/> lbf
Is this thrust present during Accel/Decel? _____	<input type="checkbox"/> Yes	<input type="checkbox"/> No

Precision

Repeatability _____	<input type="checkbox"/> μm	<input type="checkbox"/> inch
Absolute Accuracy _____	<input type="checkbox"/> μm	<input type="checkbox"/> inch
Resolution _____	<input type="checkbox"/> μm	<input type="checkbox"/> inch

Encoder Feedback

Signal Period _____	μm	
Resolution _____	<input type="checkbox"/> lines/mm	<input type="checkbox"/> lines/in
Electronic Interpolation _____	<input type="checkbox"/> Yes <input type="checkbox"/> No	If Yes, Multiplication Factor: _____

Environment

Ambient Temperature _____	<input type="checkbox"/> °C	<input type="checkbox"/> °F
Max Permissible Temperature Rise _____	<input type="checkbox"/> °C	<input type="checkbox"/> °F
Clean Room Environment _____	<input type="checkbox"/> Yes	<input type="checkbox"/> No If Yes Class: _____
Is Water or Air Cooling Permissible? _____	<input type="checkbox"/> Yes	<input type="checkbox"/> No
Vacuum? _____	<input type="checkbox"/> Yes	<input type="checkbox"/> No Pressure: _____

Amplifier & Power Supply

Max Voltage _____	VDC	
Max Current _____	Amps	
Power Supply _____	<input type="checkbox"/> Single Phase	<input type="checkbox"/> Three Phase
Voltage _____ V	<input type="checkbox"/> 50 Hz	<input type="checkbox"/> 60 Hz

Model Nomenclature

High Flex Cable Numbering System

M1C – 01

High Flex Motor Cable
M = Motor

Wire Size

1C = 18 AWG for AKD 3/6 Amp amplifiers
2C = 14 AWG for AKD 12 Amp amplifiers *
3C = 12 AWG for AKD 24 Amp amplifiers *

Length in meters

01 = 1 meter
03 = 3 meters
06 = 6 meters
09 = 9 meters
12 = 12 meters
15 = 15 meters

Example: M1C - 06

High flex motor cable, terminated with connectors at motor and amplifier ends, 18 AWG, for 3 or 6 Amp AKD.

H1C – 01

High Flex Hall Effect Cable
H1C = Hall Effect

Example: H1C - 06

High flex Hall Effect cable, terminated with connectors at motor and amplifier ends.

Length in meters

01 = 1 meter
03 = 3 meters
06 = 6 meters
09 = 9 meters
12 = 12 meters
15 = 15 meters

T1C – 01

High Flex Thermal Cable
T1C = Thermal
T2C = Thermal (S300, S600)

Example: T1C - 06

High flex Thermal cable, terminated with connectors at motor and amplifier ends.

Length in meters

01 = 1 meter
03 = 3 meters
06 = 6 meters
09 = 9 meters
12 = 12 meters
15 = 15 meters

* For application assistance regarding cable selection for these and other higher current rated amplifiers, contact a Kollmorgen Customer Support representative.

Coil Model Number Description

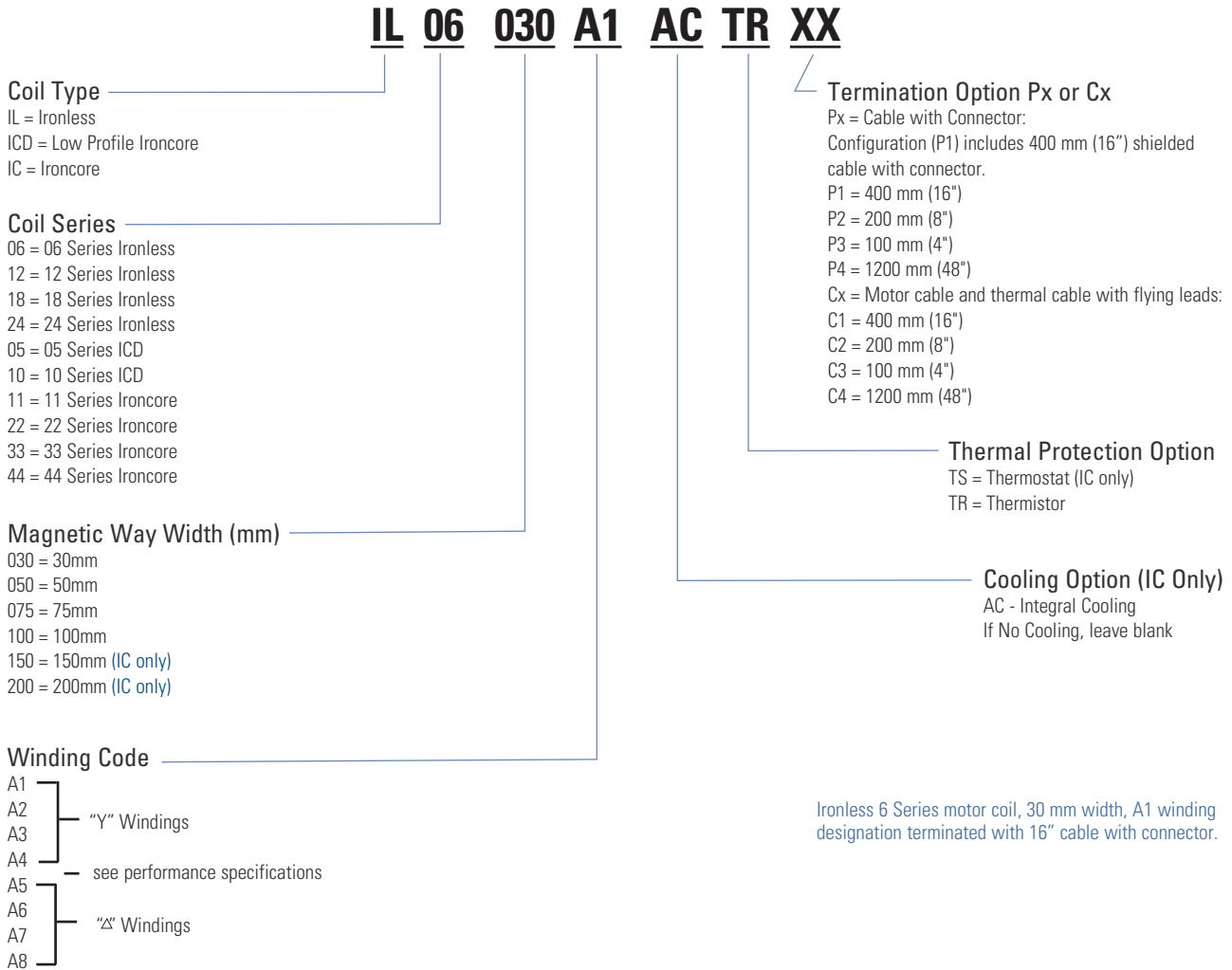

Hall Effect Assembly Model Number Description

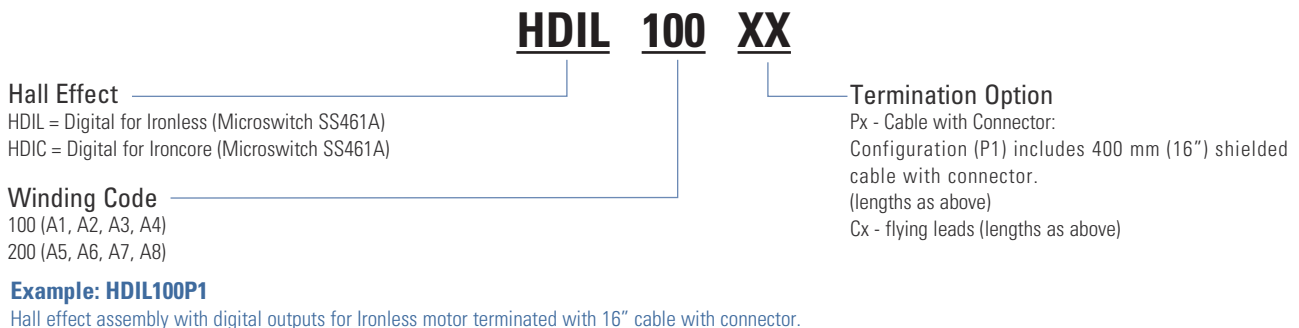

Model Nomenclature

Magnetic Way Model Number Description

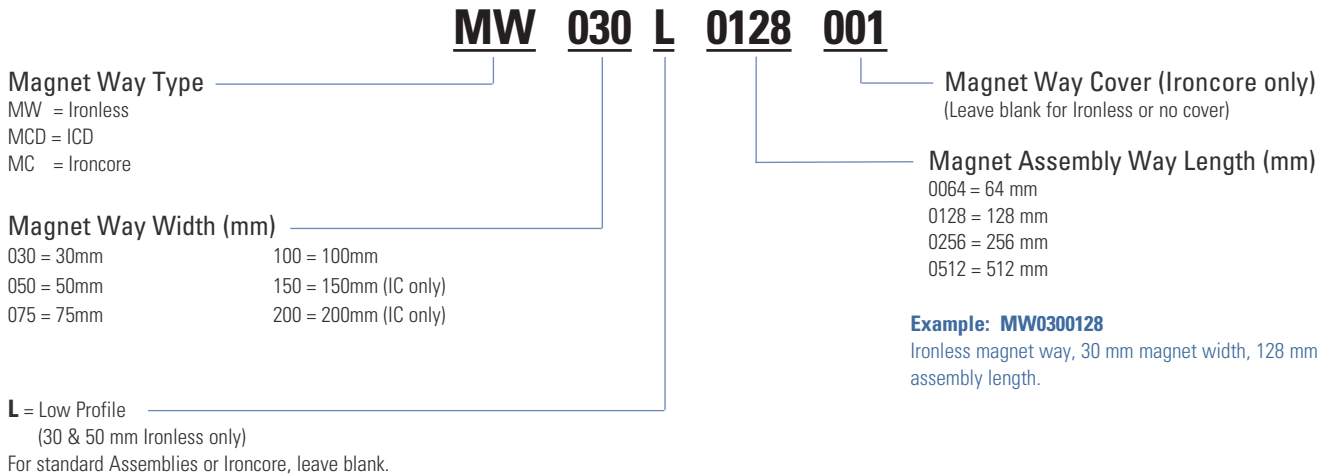

AKD Servo Drive

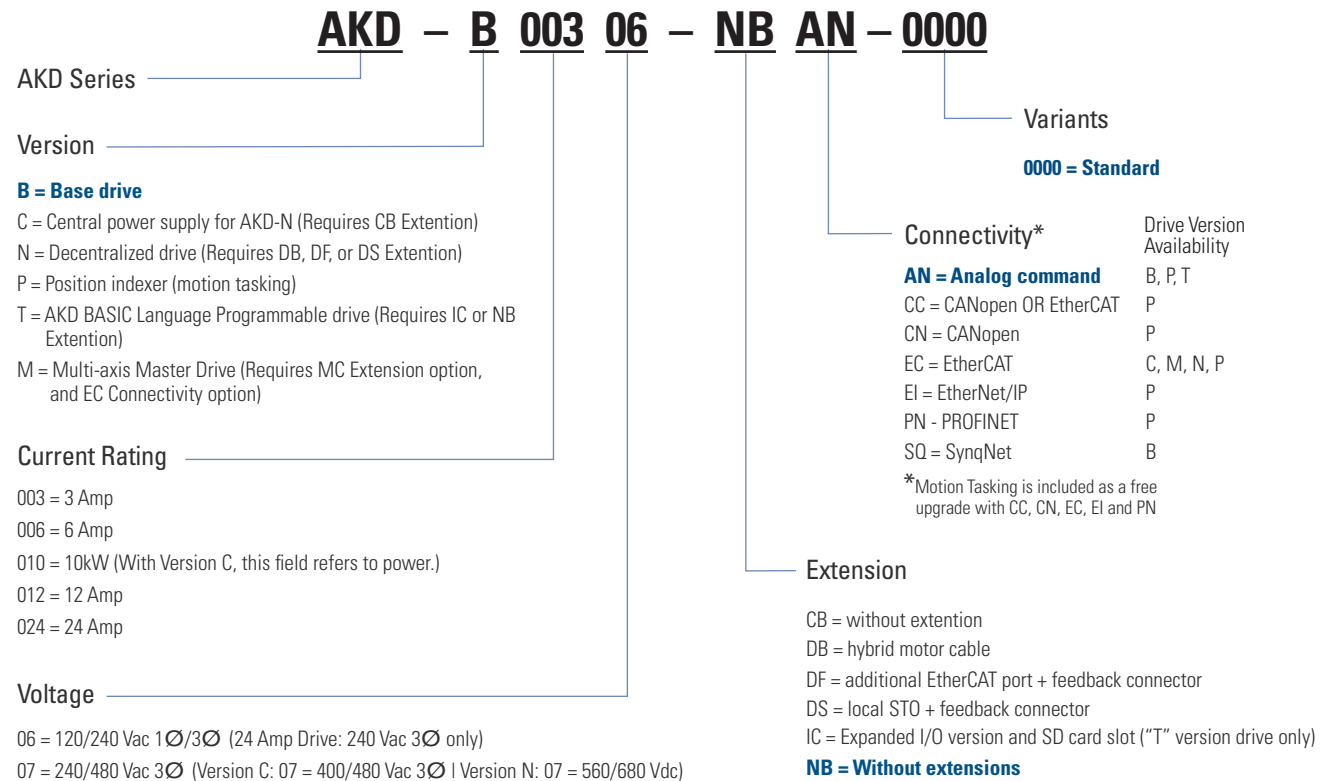

Note: Options shown in bold blue text are considered standard.

MOTIONEERING® Application Engine

To help select and size Kollmorgen components, this Windows®-based motor-sizing program takes a systems approach to the selection of brushless DC servomotors, stepper motors and drives. MOTIONEERING application engine, available at www.kollmorgen.com, uses a project concept for the collection and saving of rotary and linear multi-axis load information. This provides the user the flexibility to sum the effects of multiple axes of motion for power supply and shunt regeneration sizing.

A wide variety of linear and rotary mechanisms are provided including lead screw, rack and pinion, conveyor, nip rolls, cylinder, rotary, and direct data-entry using unique sizing algorithms and product databases criteria.

The searchable database consists of hundreds of systems on product combinations including rotary housed and frameless brushless servomotors, direct drive rotary and linear brushless servomotors, linear actuators (electric cylinders, rodless actuators, and precision tables) and stepper systems.

The MOTIONEERING application engine also provides versatile units-of-measure selection options for mechanism and motion profile data-entry, with the ability to convert data into other available units. Online Help explains program functions and the definition of terms and equations used in the program.

Features

- Group multiple mechanisms within a “project” – organize and combine data for power supply and regeneration sizing
- Types of mechanisms for analysis include lead screw, rack and pinion, conveyor, nip rolls, rotary and direct drive linear motor
- Motion profile options include simple triangle, 1/3-1/3-1/3 trapezoidal, variable traverse trapezoidal, and more
- Search results display shows color highlighted solution set of options for easy evaluation of system specifications and selection

Supported Operating Systems

- Microsoft® Windows 2000, XP, Vista, Windows 7

MOTIONEERING 6.4.0 includes

- **NEW** AKMH series Stainless Steel Motors and AKD systems at 120, 240, 400 and 480 V
 - Designed to meet IP69K, EHEDG, 3A, and built with FDA approved food grade materials
 - 19 frame/stack length combinations
 - Continuous torque to 22 Nm
 - Peak torque to 92 Nm
- Corrected length dimensions of some AKM servomotor & gearmotor models
- Corrected CH132 thermal resistance
- Added HIPERFACE DSL sine encoder to search field

Note: Performance curves included for all servomotor systems



About Kollmorgen

Kollmorgen is a leading provider of motion systems and components for machine builders. Through world-class knowledge in motion, industry-leading quality and deep expertise in linking and integrating standard and custom products, Kollmorgen delivers breakthrough solutions that are unmatched in performance, reliability and ease-of-use, giving machine builders an irrefutable marketplace advantage.

For assistance with your application needs in North America, contact us at: 540-633-3545, support@kollmorgen.com or visit www.kollmorgen.com for a global contact list.

- Application Centers
- Global Design & Manufacturing
- Global Manufacturing



KOLLMORGEN®

Because Motion Matters™



Distributors for Australia & New Zealand MOTION TECHNOLOGIES PTY LIMITED



24/22-30 Northumberland Road
Caringbah NSW 2229 Australia
Phone: (02) 9524 4782

sales@motiontech.com.au
www.motiontech.com.au

© 08/09/2023