

Distributors for Australia & New Zealand
MOTION TECHNOLOGIES PTY LIMITED



24/22-30 Northumberland Road
Caringbah NSW 2229 Australia
Phone: (02) 9524 4782

sales@motiontech.com.au
www.motiontech.com.au

© 09/11/2023



Motion Control **P**roducts

www.motiontech.com.au

ESTUN

ALL DIGITAL AC SERVO SYSTEMS

ESTUN AUTOMATION Co., Ltd. is a leading supplier and service provider of high-end automation core components and industrial robots and intelligent manufacturing systems in China.

As one of the influential enterprises in the field of motion control in China, Estun has completed the strategic transformation of its product line of automation core components from AC servo system to motion control system solutions, and its business model is fully sublimated from single axis, single machine and single unit.

Estun has actively explored the "internationalization" development strategy, successively purchased Trio from the UK and controlled M.A.I from Germany. The company invested in Barrett of America, Euclid of Italy and other companies, and established a European RESEARCH and development center in Milan, which initially completed the international layout in brand and technology, laying a solid foundation for the company to implement the development strategy in motion control solutions, intelligent collaborative robots, rehabilitation robots and industry 4.0. At present, Estun Automation has 7 overseas branches in the world, and its business covers more than 60 countries and regions.

In the future, Estun will follow the development trend of the industry, walk out a development road with Estun characteristics, take the motion control system as the first brand in China, take the mission of creating the world brand of Chinese robot, and build Estun into an international enterprise recognized and respected by peers.

A beautiful world, worthy of all our efforts

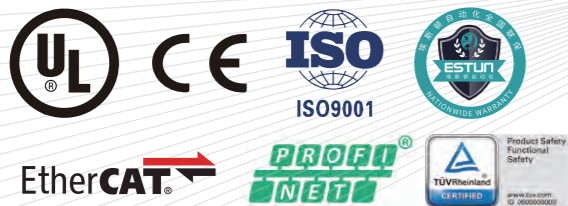

**ALL
MADE
BY ESTUN**

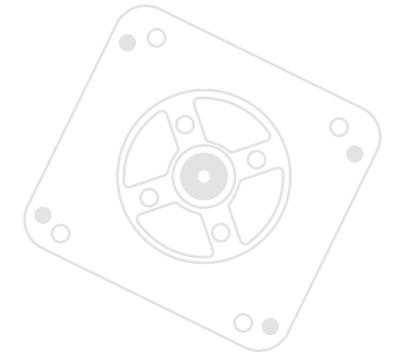

Motion Control Family	03
Controller Products	04
Smart Control Unit	07
Servo Drive & Servo Motor	09
Model comparison table	23
Accessories	28

CONTENTS

01 Motion Control Family

Industrial Complete Automation Solution



Information Layer



master control system



Border Gateway



MAINTENANCE ELF

Control Layer



Flex-7 Midi



TRIO Controller



HMI

Driving Layer



DX3 Drive



DX4 Drive



DX5 Drive



ED3L Drive



ED3S Drive

Executive Layer



MXM



MXL



EM3A



EM3J



EM3G

02 Controller Products

Conventional Controllers



	MC403	MC403-Z	MC404-Z	MC405	MC508	Euro404/Euro408
Processor	ARM11 VFP	ARM Cortex-M7	ARM Cortex-M7	ARM11 VFP	800 MHz ARM A9	ARM11 VFP
Memory	8Mb	4Mb	4Mb	8Mb	12Mb	8Mb
SD Card	16Gb	32Gb	32Gb	16Gb	16Gb	16Gb
Table	512,000	512,000	512,000	512,000	512,000	512,000
VR	4096	4096	4096	4096	16384	4096
Maximum Axes	3 Axes	4 Axes	4 Axes	5 Axes	16 Axes	8 Axes
IO Input	8	16	16	8	32	16
IO Output	4	8	8	8	16	8
Servo period	125 μs~2ms, Default 1ms	125 μs~4ms, Default 1ms	125 μs~4ms, Default 1ms	125 μs~2ms, Default 1ms	125 μs~2ms, Default 1ms	125 μs~2ms, Default 1ms
Communication	RS232/RS485	RS232/RS485	RS232/RS485	RS232/RS485	RS232/RS485	RS232/RS485
Certification	RoHS, UL, CE	RoHS, UL, CE	RoHS, UL, CE	RoHS, UL, CE	RoHS, UL, CE	RoHS, CE
Programming language	PLCopen+IEC61131-3(ST/SFC/SFC/LD/FBD)+TrioBASIC+C++					
Function	Linear, arc, helical interpolation, electronic cam, flying shear & chasing shear, CNC, Robot control					
Dimension(H x W x D)	122 mm x 135 mm x 35 mm	176.5mm x 115mm x 28mm	176.5mm x 115mm x 28mm	122mm x 186mm x 35mm	132mm x 226mm x 35mm	129mm x 25mm x 170mm
Weight	325g	430g	430g	476g	640g	160g

Accessories List

Accessories	Description
P317	CAN, 16-digital output
P318	CAN, 16-digital input
P319	CAN, 16-digital input/ output
P326	CAN, 8-analogue input/ 4-analogue output
P327	CAN, 8 Relay Output
P329	CAN, 16-digital input/16-digital output



TRIO Accessories list



Accessories	Description
P366	EtherCAT coupler
P362	Power module
P367	Thermocouple Module
P368	Thermal resistance module
P371	16-PNP output
P372	16-PNP input
P374	2-Analogue module
P375	Flexslice3 Axes module
P376	16-NPN output
P377	16-NPN input
P378	8-Analogue output
P379	8-Analogue input
P386	32-NPN output
P387	32-NPN input

EtherCAT Controller



	Flex-6-Nano	MC6N-ECAT	MC664	MC664-X	Flex-7 Midi
Processor	1GHz Arm dual-core	1 GHz Cortex A7 dual-core	Cortex A9 1GHz single-core	Cortex A9 1GHz quad-core	1.8GHz ARM A53双核
Memory	128Mbyte	128Mbyte	512Mbyte	512Mbyte	2Gbyte
SD Card	32G	16G	16G	16G	32G
Table	512000	512000	512000	512000	512000
VR	16384	64384	65536	65536	65536
Maximum Axes	64Axes	64Axes	64Axes	128 Axes	128 Axes
IO Input	-	8	8	8	-
IO Output	-	8	8	8	-
Servo period	125 μs	125 μs	125 μs	62.5 μs	62.5 μs
Communciation	-	RS232/RS485	RS232/RS485	RS232/RS485	CAN
Certifaction	CE、UL、UKCA				
Programing language	PLCopen+IEC61131-3(ST/SFC/SFC/LD/FBD)+TrioBAS C+C++				
Function	Linear, arc, helical interpolation, electronic cam, flying shear & chasing shear, CNC, Robot control				
Dimension(HxWxD)	14 x 17 x 107mm	157 x 40x 120mm	201 x 56 x 155 mm	201 x 56 x 155 mm	147x50x107mm
Weight	160g	432g	750g	750g	320g







Model	UNIPLAY 7-A	UNIPLAY 10-A	UNIPLAY 15-A
Display	7" 16:9 TFT LCD	10.1" 16:9 TFT LCD	15.6" 16:9 TFT LCD
Resolution	1024 × 600	1024 × 600	1920 × 1080
IP Grade	Front panel conforms to IP65 (installed with a flat panel), the rear shell conforms to IP20		
Panel Cut-out Dimensions	192mm × 138mm	260mm × 202mm	380mm × 245mm
Module Dimension	204mm × 145mm × 33.8mm	273mm × 213mm × 36mm	394mm × 256mm × 36mm
Weight	约580g	约950g	约2250g
Programming Environment	Function	MotionPerfect V5	Centralized program (Controller programming/servo parameter debugging) /HMI screens stored in Motion Perfect software. No need to program the HMI interface separately with other software.

03 Smart Control Unit

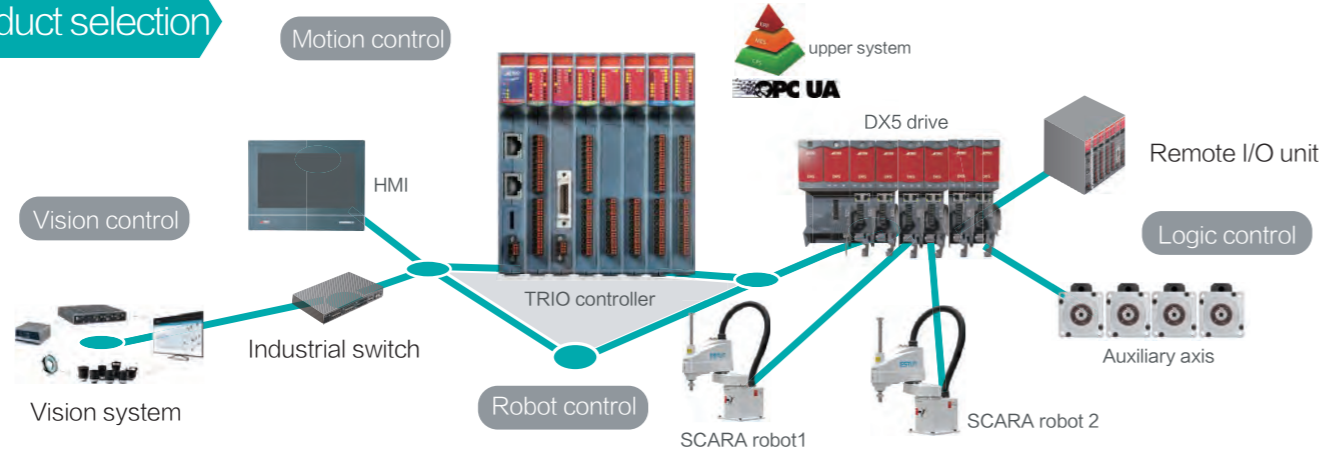
Based on the TRIO controller platform, integrate the Estun SCARA robot, servo system, vision system...etc,to realize the coordinated control of multiple robots, servo axes, and logic control by one controller, Supply the complete automation solution

Product selection



Products Type	Item Description	Remark
 Robot body  ED3L servo drive  DX5 servo drive	ER3-400-SR robot+drive	Including robot body, ED3LDriver/DX5 driver, standard wiring harness and other accessories
	ER6-500-SR robot+drive	Including robot body, ED3LDriver/DX5 driver, standard wiring harness and other accessories
	ER6-600-SR robot+drive	Including robot body, ED3LDriver/DX5 driver, standard wiring harness and other accessories
	ER6-700-SR robot+drive	Including robot body, ED3LDriver/DX5 driver, standard wiring harness and other accessories
	ER10-500-SR robot+drive	Including robot body, ED3LDriver/DX5 driver, standard wiring harness and other accessories
	ER10-600-SR robot+drive	Including robot body, ED3LDriver/DX5 driver, standard wiring harness and other accessories
	ER10-700-SR robot+drive	Including robot body, ED3LDriver/DX5 driver, standard wiring harness and other accessories
	ER10-800-SR robot+drive	Including robot body, ED3LDriver/DX5 driver, standard wiring harness and other accessories
	ER20-800-SR robot+drive	Including robot body, ED3LDriver/DX5 driver, standard wiring harness and other accessories
	ER20-1000-SR robot+drive	Including robot body, ED3LDriver/DX5 driver, standard wiring harness and other accessories
Smart Control Unit	Intelligent unit RPS controller Z101 NANO (4AXIS)	
Expansion module	TRIO Controller EC Coupler P366 FLEXSL CE COUPLERECP1(TRIO)	
	TRIO Expansion module P376 FLEXSLICE ETHERCAT I/O 16-out NPN	
	TRIO Expansion module P377 FLEXSLICE ETHERCAT I/O 16-in NPN	
Teach Pendant Cable	TR O Expansion module P375 FLEXSL CE FLEX 3-AXIS(TRIO)	
Teach pendant	Teach Pendant Cable ERT76-TPC80-A	
	Robot teaching box ERT76	

Integrated selection

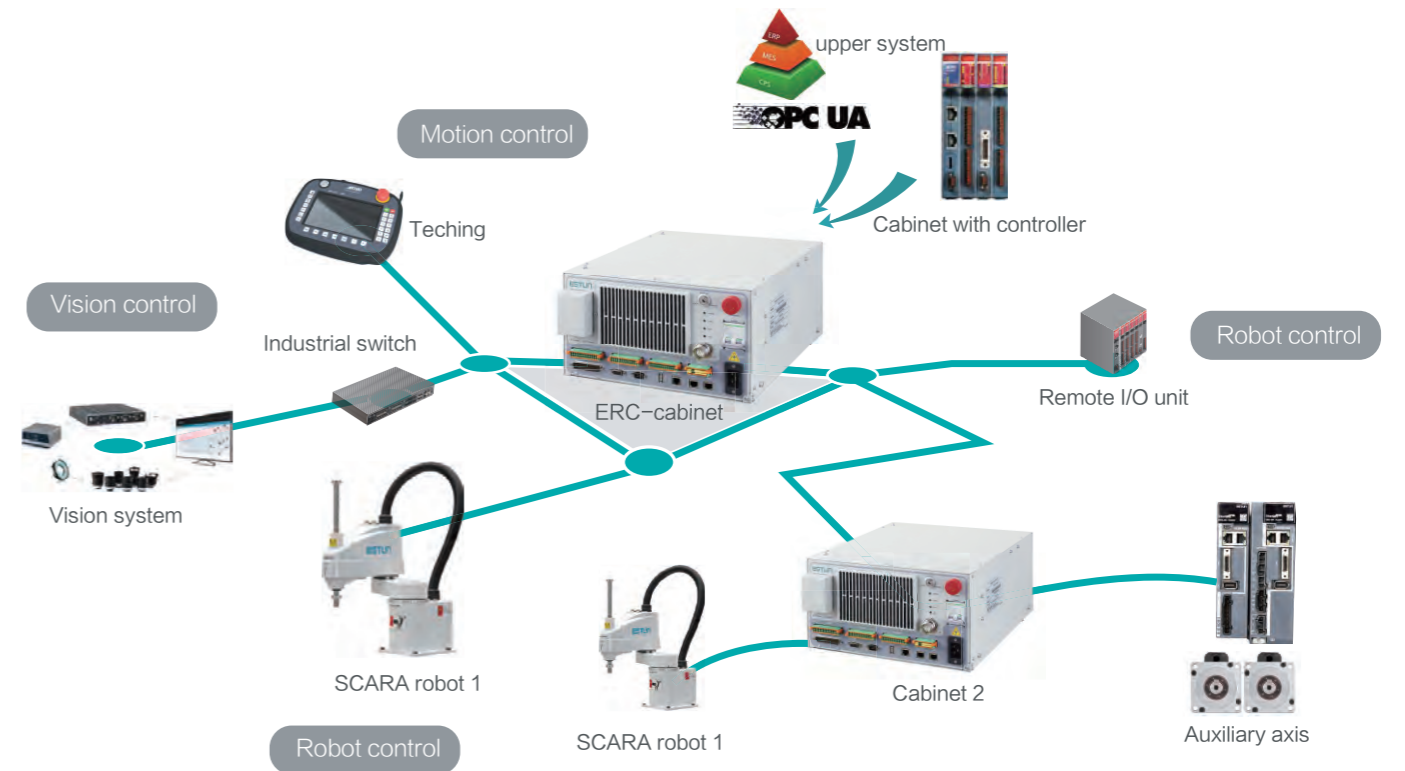

Products Type	Item Description	Remark	
 Robot body	ER3-400-SR	Max loading 3kg/wingspan 400mm	
	ER3-500-SR	Max loading 3kg/wingspan 500mm	
	ER4-550-SR	Max loading 3kg/wingspan 500mm	
	ER6-500-SR	Max loading 3kg/wingspan 500mm	
	ER6-600-SR	Max loading 3kg/wingspan 500mm	
	ER6-700-SR	Max loading 3kg/wingspan 500mm	
	ER10-500-SR	Max loading 10kg/Wingspan500mm	
	ER10-600-SR	Max loading 10kg/Wingspan600mm	
	ER10-700-SR	Max loading 10kg/Wingspan700mm	
	ER10-800-SR	Max loading 10kg/Wingspan800mm	
	ER20-800-SR	Max loading 20kg/Wingspan800mm	
	ER20-1000-SR	Max loading 20kg/Wingspan1000mm	
	ER50-1200-SR	Max loading 50kg/Wingspan1200mm	
	 Robot cabinet	ERC-C-ENA4A	No controller, no teach pendant support, applied in 10/6/3kgSCARA, O-PNP
		ERC-C-E7A4A	With controller, no teach pendant support, applied in 10/6/3kgSCARA, IO-PNP
ERC-C-E7B4A		With controller, no teach pendant support, applied in 20kgSCARA, IO-PNP	
ERC-C-ENA4A-N		No controller, no teach pendant support, applied in 10/6/3kgSCARA, O-NPN	
ERC-C-E7A4A-N		With controller, no teach pendant support, applied in 10/6/3kgSCARA, O-NPN	
ERC-C-E7B4A-N		With controller, no teach pendant support, applied in 20kgSCARA, IO-NPN	
ERC-C-E7A4A-T		With controller, teach pendant support, applied in 10/6/3kgSCARA, IO-PNP	
ERC-C-E7B4A-T		With controller, teach pendant support, applied in 20kgSCARA, IO-PNP	
ERC-C-E7A4A-N-T		With controller, teach pendant support, applied in 10/6/3kgSCARA, IO-NPN	
ERC-C-E7B4A-N-T	With controller, teach pendant support, applied in 20kgSCARA, IO-NPN		

04 Servo drive & Servo motor

Single axis servo drive

ED3L - 04 A E A - FS02

ED3L Servo drive

Rated output power

Voltage supply

Options

Encoder type

Extended function



A5	0.05kW
01	0.1kW
02	0.2kW
04	0.4kW
08	0.75kW
10	1.0kW
15	1.5kW
20	2.0kW
30	3.0kW
50	5.0kW
75	7.5kW

A	200VAC
D	400VAC

E	EtherCAT
M	CANopen,pulse
P	Profinet

A	Serial encoder
C	Linear encoder

FS02 Support the STO

Note: 1, Please refer to Model Comparison Table for details.
2, Only ED3L-04AEC and ED3L-10AEC support linear motors
3, The default model does not contain extended functions

200VAC

Driver model:ED3L-	A5A	01A	02A	04A	08A	10A	15A	20A
Continuous output current[Arms]	0.9	1.1	1.5	2.9	5.1	6.9	9.5	12.6
Maximum output current[Arms]	3.3	4.0	5.8	11.5	19.5	21.0	31.6	42.0
Capacity of main power supply[kVA] (Single phase)	0.2	0.3	0.6	1.2	1.9	2.6	4.0	-
Capacity of main power supply[kVA] (Three-phase)	-	-	-	-	1.6	2.0	3.0	3.5

400VAC

Driver model:ED3L-	10D	15D	20D	30D	50D	75D
Continuous output current[Arms]	3.6	5.0	7.1	12.0	17.0	27.3
Maximum output current[Arms]	10.9	16.3	21.2	36.6	53.0	70.0
Capacity of main power supply[kVA] (Three-phase)	1.8	2.8	3.5	5.0	8.2	12.0

Single axis, 200VAC , Rated power: 50W~400W

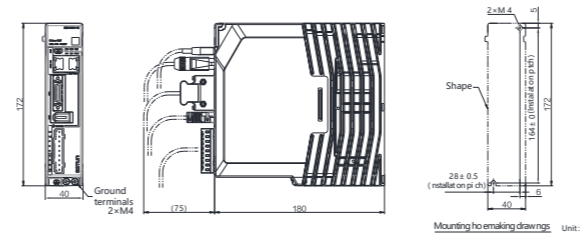

Single axis, 200VAC , Rated power: 750W~1KW

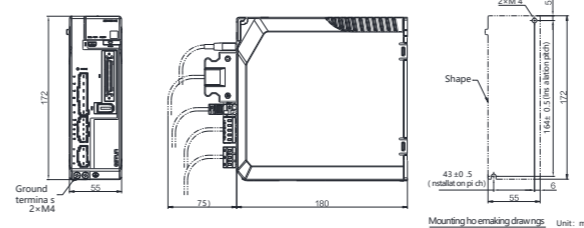

Single axis, 200VAC , Rated power: 1.5kW~2KW

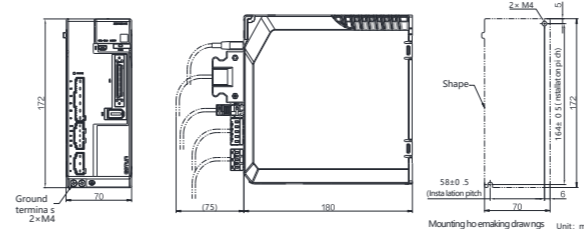

Single axis, 400VAC , Rated power: 1kW~1.5KW

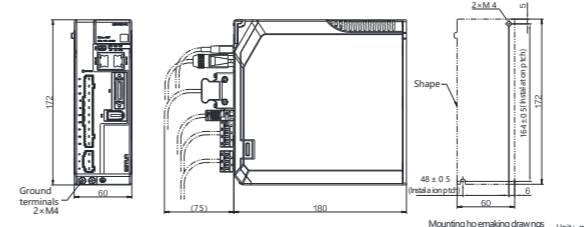

Single axis, 400VAC , Rated power: 2kW~3KW

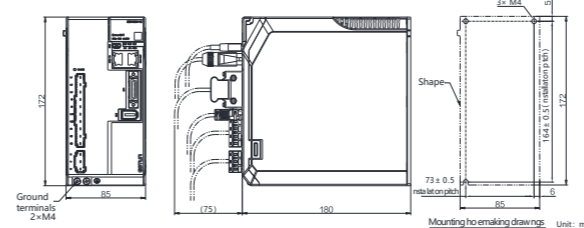

Single axis, 400VAC , Rated power: 5kW~7.5KW

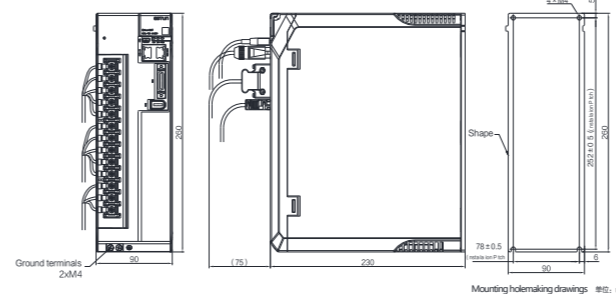

General specification	Description
Input power	200VAC Single-phase AC 200V to 240VAC 200V~240V, -15%~+10%, 50Hz/60Hz 400VAC Three-phase AC 200V~240V, -15%~+10%, 50Hz/60Hz (Power ≥ 0.75kw) Three-phase AC 380V~440V, -15%~+10%, 50Hz/60Hz
Operation conditions	Work environment Temperature When used on a single device: -5°C~55°C; When multiple devices are installed snugly: -5°C~40°C Humidity 5% to 95% (with no condensation)
	Storage environment Temperature -20°C~85°C Humidity 5% to 95% (with no condensation)
	Protection Class IP20
	Altitude Below 1000 m
Performance	Vibration resistance Vibration Resistance:4.9m/s ² ; Impact resistance Shock Resistance:19.6m/s ²
	Power System TN System
Installation structure	Base-mounted
Performance	Coefficient of speed fluctuation 0.01% of rated speed max.(For a load fluctuation of 0% to 100%) 0% of rated speed max. (For a load fluctuation of 10%) 0.1% of rated speed max. (For a temperature fluctuation of 25°C 25°C)
	Soft start time setting 0 s to 10 s (Can be set separately for acceleration and deceleration.)
	USB communication Conforms to USB2.0 standard (12 Mbps)
Display	5 bit digital tube
Panel operator	4 Buttons
Regenerative braking	50W ~ 400W products without built-in brake resistance Other power products have built-in brake resistance
Protection function	Overcurrent, Overvoltage, Undervoltage, Overload, Regeneration Error, Overspeed, etc.
Utility Functions	Alarm recording, JOG running, load inertia recognition, mechanical analyzer, automatic setting tools, etc

Bus type specifications	Description
Power range	50W~7.5kW
I/O Signals	Input Signals Allowable voltage range: 24 VDC 20% Number of input points: 5 (Two fixed channels can be used for Touch Probe)
	Output Signals Operating voltage range: 5 VDC to 30 VDC Number of output points: 3 (1 of them fixed for Servo Alarm)
Communications and Standards	Standard EtherCAT/ProfiNet protocol and rules

Pulse type specifications	Description
Power range	50W~7.5kW
I/O Signals	Encoder pulse division output A-phase, B-phase, C-phase: line drive output Number of divider pulses: Arbitrary frequency division
	Input Signals Operating voltage range: 24 VDC 20% Number of input points: 10 (Two fixed channels can be used for Touch Probe)
Torque Control	External input DC 10V (DC 0V~ 10V: Variable setting range)
	Built-in set 4 torque contacts
Speed control	External input DC 10V (DC 0V~ 10V: Variable setting range)
	Built-in set Speed 1 to Speed 7
Position control	External input Choose one of the following input types Symbol + Pulse Column; CCW + CW Pulse Column; 90° Phase Difference 2 Phase Pulse (A Phase + B Phase)
	Built-in set 32 location contacts

linear drive	Description
Power range	100W~1.0kW
I/O Signals	Input Signals Allowable voltage range: 24 VDC 20% Number of input points: 5
	Output Signals Allowable voltage range: 5 VDC to 30 VDC Number of output points: 3 (One of the fixed channels is used for servo alarm)
Encoder	Pulse signal A, B, Z (Difference) Hall signal 5V single-ended signal
Communications & Standards	Standard EtherCAT protocol and rules

Dual axis servo drive

ED3L – 04 04 A E A

ED3L Servo drive A-axis output power B-axis output power Voltage supply Options Encoder type

04	0.4KW		A	200VAC	E	EtherCAT	A	Serial encoder
10	1.0KW				M	CANopen, pulse		

Note:
1, suitable for EM3A, EM3J, EM3G servo motor



Driver model:ED3L-	0404A		1010A	
Continuous output current[Arms]	2.9	2.9	6.9	6.9
Maximum output current[Arms]	11.5	11.5	21.0	21.0
Capacity of main power supply[kVA] (Single phase)	1.9		4.5	
Capacity of main power supply[kVA] (Three-phase)	1.6		3.8	

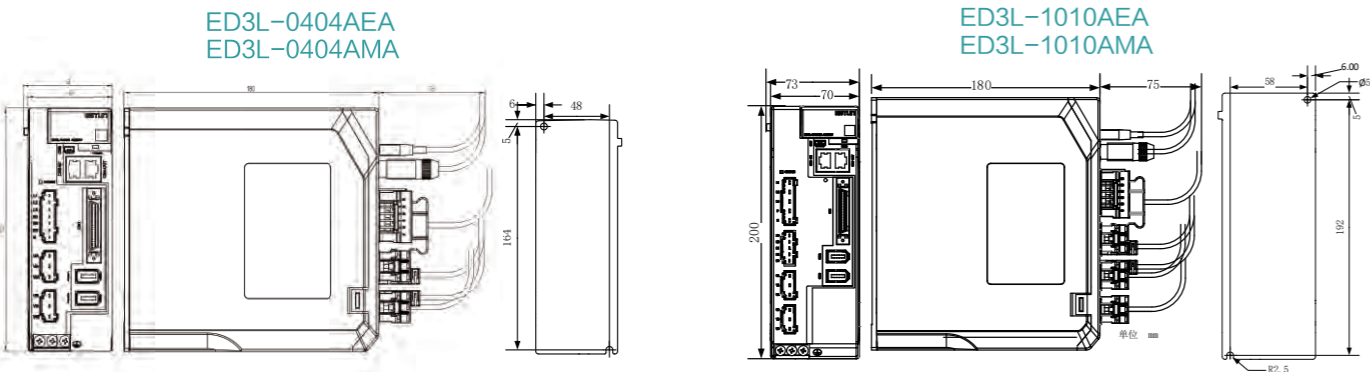

Item		Specifications	
ED3L-		0404AEA/1010AEA	0404AMA/1010AMA
Input power	Main circuit	Single phase 200 ~ 240VAC +10% ~ -15% (50/60Hz) Three-phase 200 ~ 240VAC +10% ~ -15% (50/60Hz)	
	Control voltage	Single phase 200 ~ 240VAC +10% ~ -15% (50/60Hz)	
	Control mode	SVPWM	

Item		Specifications	
ED3L-		0404AEA/1010AEA	0404AMA/1010AMA
Operation conditions	Service temperature/Storage temperature	Operating temperature: -5~55°C/ storage temperature: -20~85°C	
	Use humidity/store humidity	5%~95%RH(no condensation, no freezing)	
	Resistance to vibration/impact	Vibration resistance:4.9m/s ² /Impact resistance:19.6m/s ²	
Installation structure		Installed base	
Speed control	Speed setting instruction	Direction selection	Only the parameter speed control mode is supported
		Speed selection	/
	Function	Soft start setting	0~10s(acceleration and deceleration can be set separately)
Position control	Command pulse	Species	/
		Form	/
		Frequency	/
	Set position instruction	/	32 position nodes can be set
Input-output signal	Sequential input signal	Channel number	5 channels
		Function	Input signal is S-ON (servo enable), P-CON (proportional control), ALM-RST (alarm reset), CLR (position deviation clearance), P-OT (positive drive prohibition), N-OT (reverse drive prohibition), PCL (positive torque limit), NCL (negative torque limit). Except for Touch Probe, other signals can be allocated and the positive and negative logic can be changed.
	Sequential output signal	Channel number	3 channels
		Function	The output signal is: COIN (positioning completion), VCMP (same-speed detection), TGON (motor rotation detection), ALM (servo alarm), S-RDY (servo ready), BK (brake), PGC (encoder C pulse), OT (overrange detection), HOME (zero return completion), REMOTE (REMOTE IO), TCR (torque detection). Except for ALM, all signals can be assigned and the positive and negative logic can be changed.
Built-in function	Protection function		Over current, over voltage, under voltage, over load, regenerative fault, overspeed, etc
	Auxiliary function		Alarm recording, JOG operation, load inertia identification, mechanical analyzer, automatic setting tools, etc
	Communications functions		EtherCAT communication module uses CiA402 protocol
	Display function		Five digital tubes, five buttons
		CHARGE, POWER, SYS, RUN, ERR, L/A OUT, AXIS-A/B	

EM3A servo motor(50W ~ 1.0kW)

Small capacity | High speed | Low inertia

EM3A – 04 A L A 2 4 1



Rated output power

A5	0.05kW
01	0.1kW
02	0.2kW
04	0.4kW
08	0.75kW
10	1.0kW

Voltage grade

A	200VAC
---	--------

encoder

T	17-bits absolute
L	23-bits absolute

Design order

A	-
---	---

Shaft end

2	Straight, with keys, Threaded
---	-------------------------------

Optional

1	No oil seals, No brakes
2	With oil seal, No brakes
3	No oil seals, With brake
4	With oil seal, With brake

Plug type

1	Standard plugs
2	Waterproof plug

Note: 1. Please refer to Model Comparison Table for details.
2. Motor body heat resistance class: F
3. Motor body protection mode: self-cooling, IP65/IP67

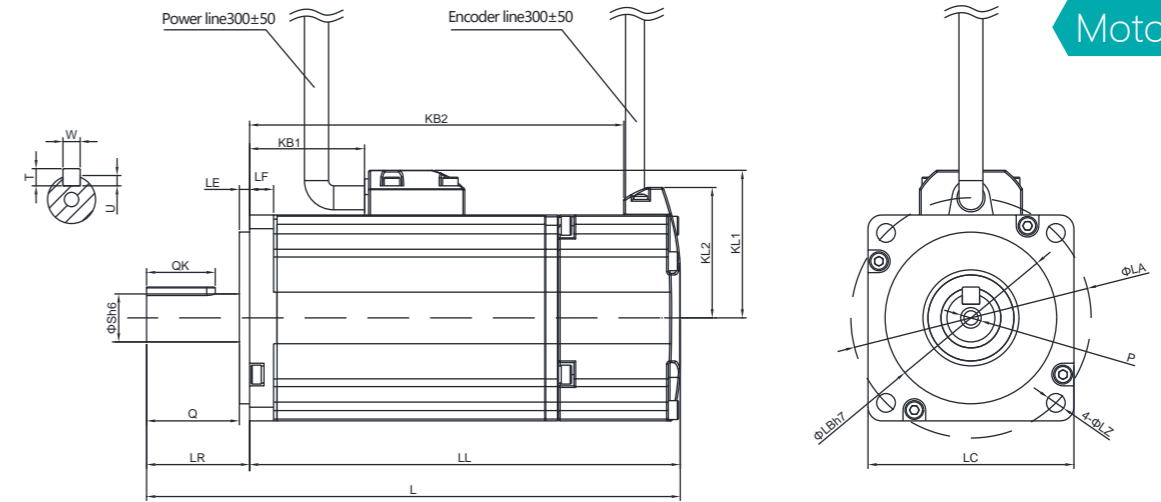

Motor size

Power	EM3A-	L	LL	KB1	KB2	KL1	KL2	Flange Dimensions							S	P	key				
								LR	LE	LF	LC	LA	LB	LZ			QK	Q	W	T	U
50W	A5AL	87.5 (121)	62.5 (96)	19.8(32.8)	48.3(81.8)	33	33	25	2.5	5	40	46	30	4.3	8	M3× 6	14	22	3	3	1.8
100W	01AL	103.5(137)	78.5 (112)	35.8(48.8)	64.3(97.8)	33	33	25	2.5	5	40	46	30	4.3	8	M3× 6	14	22.5	3	3	1.8
100W	01AT	113.5(147)	88.5(122)	35.8(48.8)	74.3(107.8)	33	33	25	2.5	5	40	46	30	4.3	8	M3× 6	14	22.5	3	3	1.8
200W	02AL	108 (137)	78 (107)	27.5(33.5)	61.5(90.5)	43	38	30	3	7	60	70	50	5.5	14	M5× 12	20	27	5	5	3
200W	02AT	126.5(155.5)	96.5(125.5)	42.7(48.7)	80 (109)	43	38	30	3	7	60	70	50	5.5	14	M5× 12	20	27	5	5	3
400W	04AL	129 (158)	99 (128)	48.5(54.5)	82.5(111.5)	43	38	30	3	7	60	70	50	5.5	14	M5× 12	20	27	5	5	3
400W	04AT	147.5(176.5)	117.5(146.5)	48.5(54.5)	101(130)	43	38	30	3	7	60	70	50	5.5	14	M5× 12	20	27	5	5	3
750W	08AL	151 (184)	111(144)	58.2(59.2)	35.8(67.8)	53	48	40	3	8	80	90	70	6.6	19	M6× 12	25	37/35	6	6	3.5
750W	08AT	167.5(200.5)	127.5(160.5)	58.2(59.2)	52.3(84.3)	53	48	40	3	8	80	90	70	6.6	19	M6× 12	25	37	6	6	3.5
1.0kW	10AL	165 (198)	125(158)	72.2(73.2)	35.8(67.8)	53	48	40	3	8	80	90	70	6.6	19	M6× 12	25	37	6	6	3.5
1.0kW	10AT	181.5(214.5)	141.5(174.5)	72.2(73.2)	34.3(56.3)	53	48	40	3	8	80	90	70	6.6	19	M6× 12	25	37	6	6	3.5

Note: The values in parentheses represent the values of motors with brakes.

		200VAC											
EM3A-		A5AT	A5AL	01AT	01AL	02AT	02AL	04AT	04AL	08AT	08AL	10AT	10AL
Flange [mm]		40	40	60	60	80	80						
Rated power [kW]		0.05	0.1	0.2	0.4	0.75	1.0						
Rated speed[r/min]		3000	3000	3000	3000	3000	3000						
Maximum speed [r/min]		6000	6000	6000	6000	6000	6000						
Rated torque [N·m]		0.159	0.318	0.637	1.27	2.39	3.18						
Maximum torque [N·m]		0.557	0.954	1.11	1.91	2.23	3.81	4.46	7.17	8.37	9.54		
Rated current [Arms]		0.9	1.1	1.5	2.9	5.1	6.9						
Maximum current [Arms]		3.3	3.5	4.0	4.7	5.8	9.2	11.5	16.1	19.5	21.0		
Motor inertia [10 ⁻⁴ kg · m ²]		0.0230(0.0268)	0.0428(0.0465)	0.147(0.179)	0.244(0.276)	0.910(1.07)	1.14(1.30)						
Allowable shaft end load	Radial[N]	78	78	245	245	392	392						
	Axial[N]	54	54	74	74	147	147						
Brake specification	Rated voltage	24VDC	24VDC	24VDC	24VDC	24VDC	24VDC						
	Holding torque[N·m]	≥0.32	≥0.32	≥1.5	≥1.5	≥3.2	≥3.2						
Weight[kg]		0.4(0.6)	0.5(0.7)	0.9(1.3)	1.3(1.7)	2.6(3.2)	3.1(3.8)						

Note: The values in parentheses represent the values of motors with brakes.

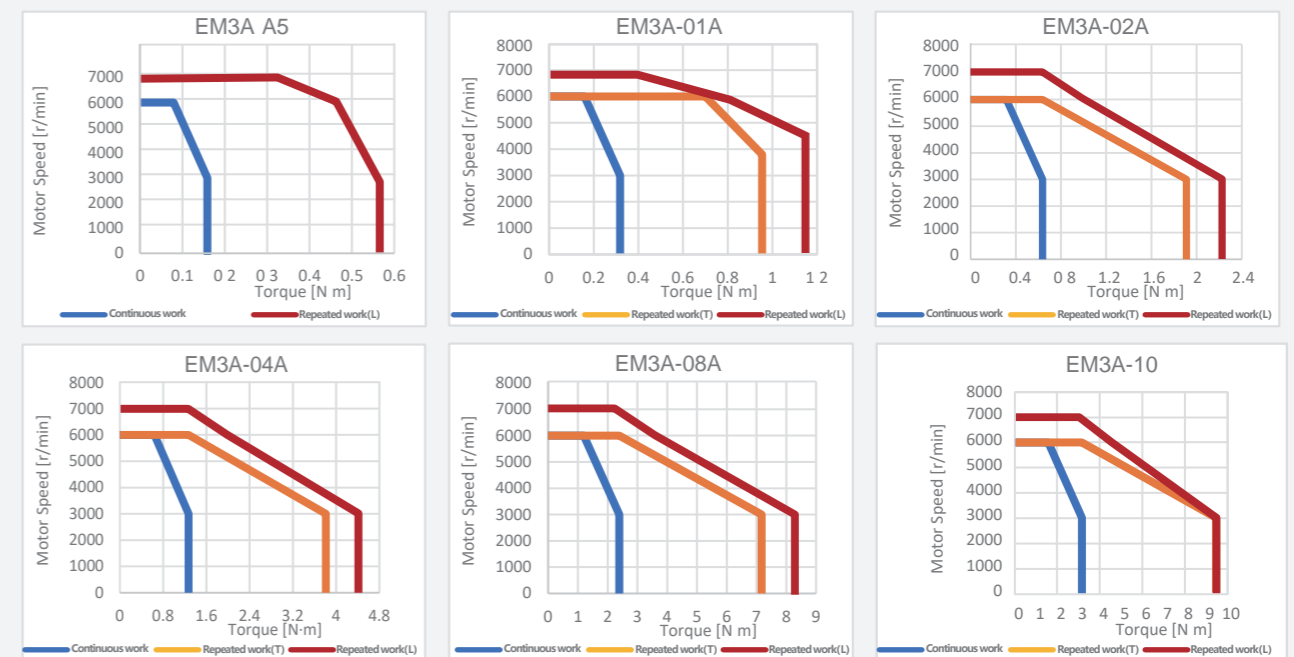

EM3A servo motor(1.5kw~5kW)

Medium capacity | High speed | Low inertia

Motor size

EM3A – 15 A L B 2 2 4



Rated output power

15	1.5kW
20	2.0kW
30	3.0kW
40	4.0kW
50	5.0kW

Voltage grade

A	200VAC
D	400VAC

encoder

17-bits absolute
23-bits absolute

Design order

A	-
---	---

Shaft end

2	Straight, with keys, Threaded
---	-------------------------------

Optional

1	No oil seals, No brakes
2	With oil seal, No brakes
3	No oil seals, With brake
4	With oil seal, With brake

Plug type

4	Aviation Plug
---	---------------

Note: 1. Please refer to Model Comparison Table for details.
2. Motor body heat resistance class: F
3. Motor body protection mode: self-cooling, IP65

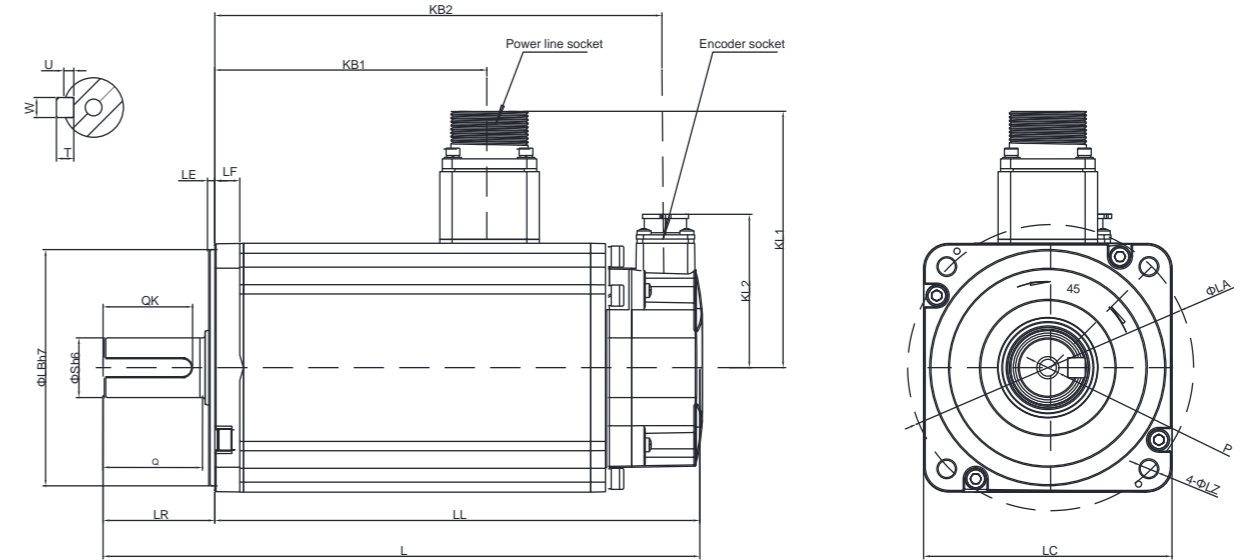

	200VAC		400VAC					
	15A	20A	15D	20D	30D	40D	50D	
EM3A-								
Flange [mm]	100	100	100	100	130	130	130	
Rated power [kW]	1.5	2.0	1.5	2.0	3.0	4.0	5.0	
Rated speed [r/min]	3000	3000	3000	3000	3000	3000	3000	
Maximum speed [r/min]	5000	5000	5000	5000	5000	5000	5000	
Rated torque [N·m]	4.78	6.37	4.78	6.37	9.80	12.8	15.9	
Maximum torque [N·m]	14.3	19.1	14.3	19.1	29.4	38.4	47.7	
Rated current [Arms]	9.5	12.6	4.9	6.4	10.5	13.0	15.9	
Maximum current [Arms]	31.6	42.0	16.3	20.5	33.0	40.0	50.0	
Motor inertia [10 ⁻⁴ kg·m ²]	2.33(3.10)	2.95(3.72)	2.33(3.10)	2.95(3.72)	7.72(9.00)	10.2(11.6)	14.0(15.4)	
Allowable shaft end load	Radial [N]	686	686	686	686	980	980	980
	Axial [N]	196	196	196	196	392	392	392
Brake specification	Rated voltage	24VDC	24VDC	24VDC	24VDC	24VDC	24VDC	24VDC
	Holding torque [N·m]	≥8	≥8	≥8	≥8	≥20	≥20	≥20
Weight [kg]	5.1(6.4)	6.1(7.5)	5.1(6.4)	6.1(7.5)	10.0(12.0)	12.0(14.0)	15.5(17.5)	

Note: The values in parentheses represent the values of motors with brakes.

Power	EM3A-	L	LL	KB1	KB2	KL1	KL2	Flange Dimensions							S	P	key				
								LR	LE	LF	LC	LA	LB	LZ			QK	Q	W	T	U
1.5kW	15□	210(240)	165(195)	97(109)	150(180)	102	60	45	3	10	100	115	95	7	24	M8×16	36	40	8	7	4
2.0kW	20□	230(260)	185(215)	117(129)	170(200)	102	60	45	3	10	100	115	95	7	24	M8×16	36	40	8	7	4
3.0kW	30D	257(289.5)	194(226.5)	160.5	179(211.6)	110	60	63	6	12	130	145	110	9	28	M8×16	54	55	8	7	4
4.0kW	40D	284(316.5)	221(253.5)	187.5	206(238.5)	110	60	63	6	12	130	145	110	9	28	M8×16	54	55	8	7	4
5.0kW	50D	324(356.5)	261(293.5)	227.5	246(278.5)	110	60	63	6	12	130	145	110	9	28	M8×16	54	55	8	7	4

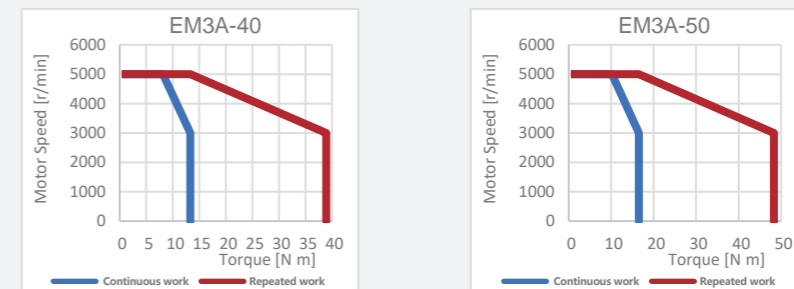
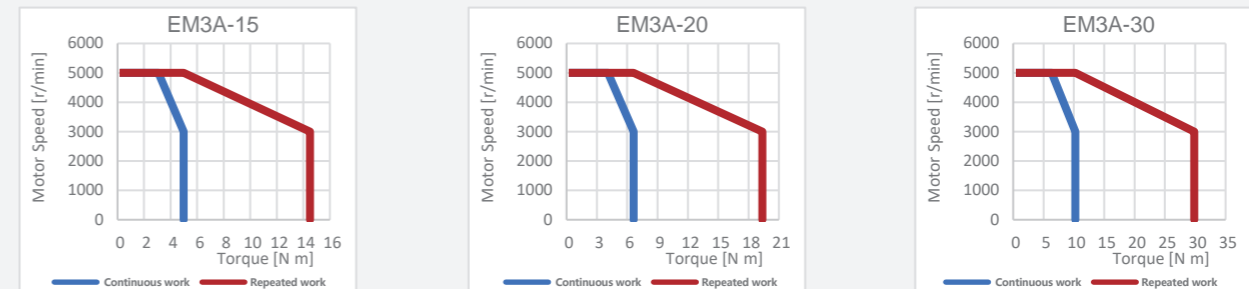

EM3J servo motor (200W ~ 1.0kW)

Small capacity | High speed | Medium inertia

EM3J - 04 A L A 2 4 2

Rated output power Voltage grade encoder Design order Shaft end Optional Plug type



02	0.2kW
04	0.4kW
08	0.75kW
10	1.0kW

A	200VAC
D	400VAC

T	17-bits absolute
L	23-bits absolute

2	Straight, with keys, Threaded
---	-------------------------------

1	No oil seals, No brakes
2	With oil seal, No brakes
3	No oil seals, With brake
4	With oil seal, With brake

1	Standard plugs
2	Waterproof plug

Note: 1. Please refer to Model Comparison Table for details.
2. Heat resistance grade of motor body: F
3. Motor body protection mode: self-cooling, IP65/IP67

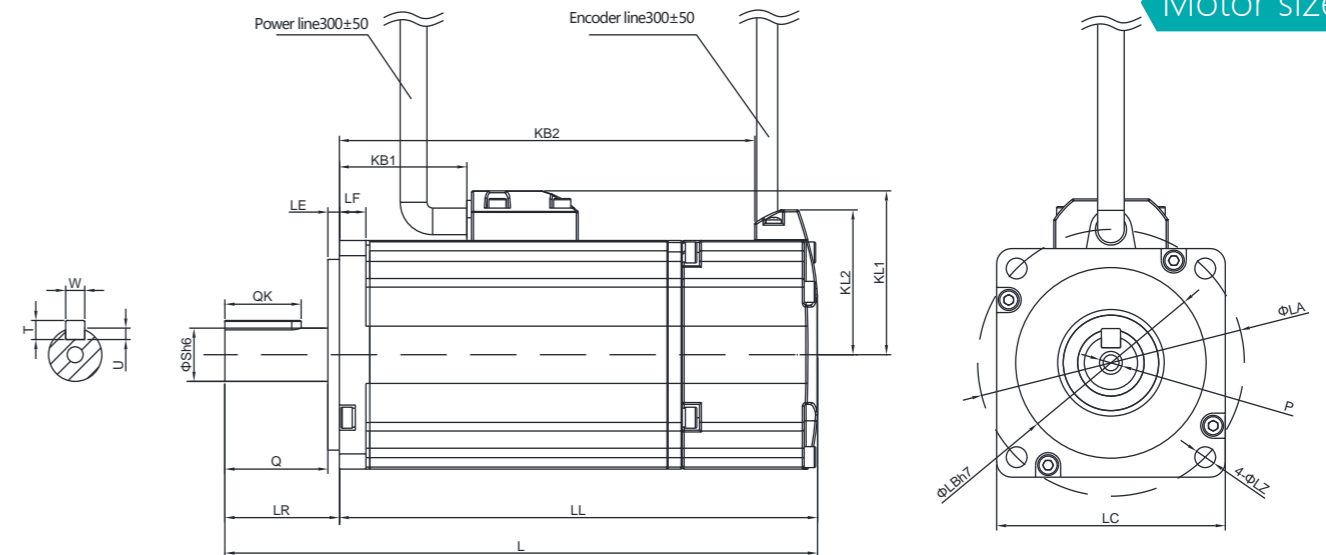

Power	EM3J-	L	LL	KB1	KB2	KL1	KL2	Flange Dimensions							S	P	key				
								LR	LE	LF	LC	LA	LB	LZ			OK	Q	W	T	U
200W	02AL	108(137)	78(107)	27.5(33.5)	61.5(90.5)	43	38	30	3	7	60	70	50	5.5	14	M5 × 12	20	27	5	5	3
200W	02AT	126.5(155.5)	96.5(125.5)	42.7(48.7)	80(109)	43	38	30	3	7	60	70	50	5.5	14	M5 × 12	20	27	5	5	3
400W	04AL	129(158)	99(128)	48.5(54.5)	82.5(111.5)	43	38	30	3	7	60	70	50	5.5	14	M5 × 12	20	27	5	5	3
400W	04AT	147.5(176.5)	117.5(146.5)	48.5(54.5)	101(130)	43	38	30	3	7	60	70	50	5.5	14	M5 × 12	20	27	5	5	3
750W	08AL	142(175)	102(135)	58.2(59.2)	35.8(67.8)	53	48	40	3	8	80	90	70	6.6	19	M6 × 12	25	37	6	6	3.5
750W	08AT	158.5(191.5)	118.5(151.5)	58.2(59.2)	52.3(84.3)	53	48	40	3	8	80	90	70	6.6	19	M6 × 12	25	37	6	6	3.5
1.0kW	10AL	157(190)	117(150)	72.2(73.2)	34.3(56.3)	53	48	40	3	8	80	90	70	6.6	19	M6 × 12	25	37	6	6	3.5
1.0kW	10AT	173.5(206.5)	133.5(166.5)	72.2(73.2)	34.3(56.3)	53	48	40	3	8	80	90	70	6.6	19	M6 × 12	25	37	6	6	3.5

Note: The values in parentheses represent the values of motors with brakes.

		200VAC							
EM3J-		02AT	02AL	04AT	04AL	08AT	08AL	10AT	10AL
Flange [mm]		60		60		80		80	
Rated power [kW]		0.2		0.4		0.75		1.0	
Rated speed [r/min]		3000		3000		3000		3000	
Maximum speed [r/min]		6000		6000		6000		6000	
Rated torque [N·m]		0.637		1.27		2.39		3.18	
Maximum torque [N·m]		1.91	2.23	3.81	4.46	7.17	8.37	9.54	
Rated current [Arms]		1.5		2.8		5.1		7.1	
Maximum current [Arms]		4.7	5.8	8.8	11.2	16.1	19.5	22.0	
Motor inertia [10 ⁻⁴ kg·m ²]		0.330(0.360)		0.640(0.680)		1.64(1.79)		2.26(2.41)	
Allowable shaft end load	Radial [N]	245		245		392		392	
	Axial [N]	74		74		147		147	
Brake specification	Rated voltage	24VDC		24VDC		24VDC		24VDC	
	Holding torque [N·m]	≥1.5		≥1.5		≥3.2		≥3.2	
Weight [kg]		0.9(1.3)		1.3(1.7)		2.3(2.9)		3.1(3.8)	

Note: The values in parentheses represent the values of motors with brakes.

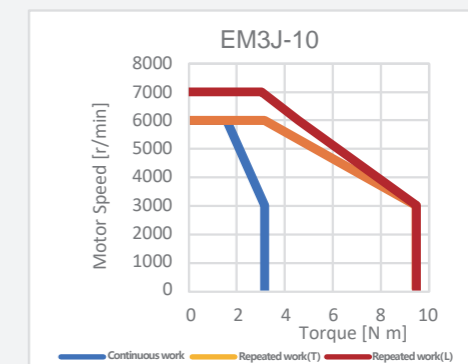
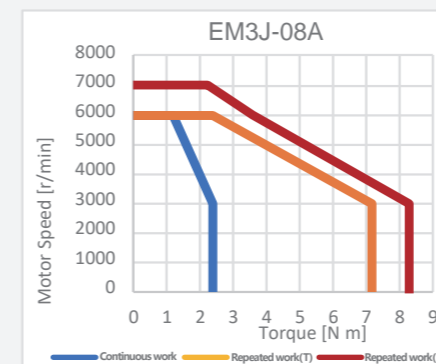
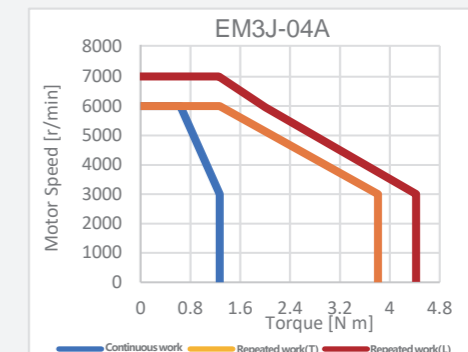
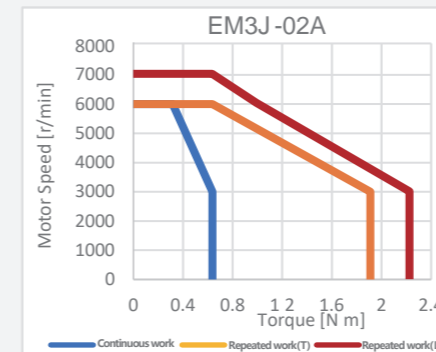

EM3G servo motor(0.85kW~7.5kW)

Medium capacity | Medium speed | Medium inertia

Motor size

EM3G-13 A L A 2 2 4



Rated output power Voltage grade encoder Design order Shaft end Optional Plug type

09	0.85kW
13	1.3kW
18	1.8kW
29	2.9kW
44	4.4kW
55	5.5kW
75	7.5kW

A	200VAC
D	400VAC

T	17-bits absolute
L	23-bits absolute

A	-
---	---

2	St aight,with keys, Threaded
---	------------------------------

1	No oil seals,No b akes
2	With oil seal,No brakes
3	No oil seals,With brake
4	With oil seal,With brake

4	Aviation Plug
---	---------------

Note:1、 Please refer to Model Comparison Table for details.
2、 Motor body heat resistance class: F
3、 Motor body protection mode: self-cooling, IP65

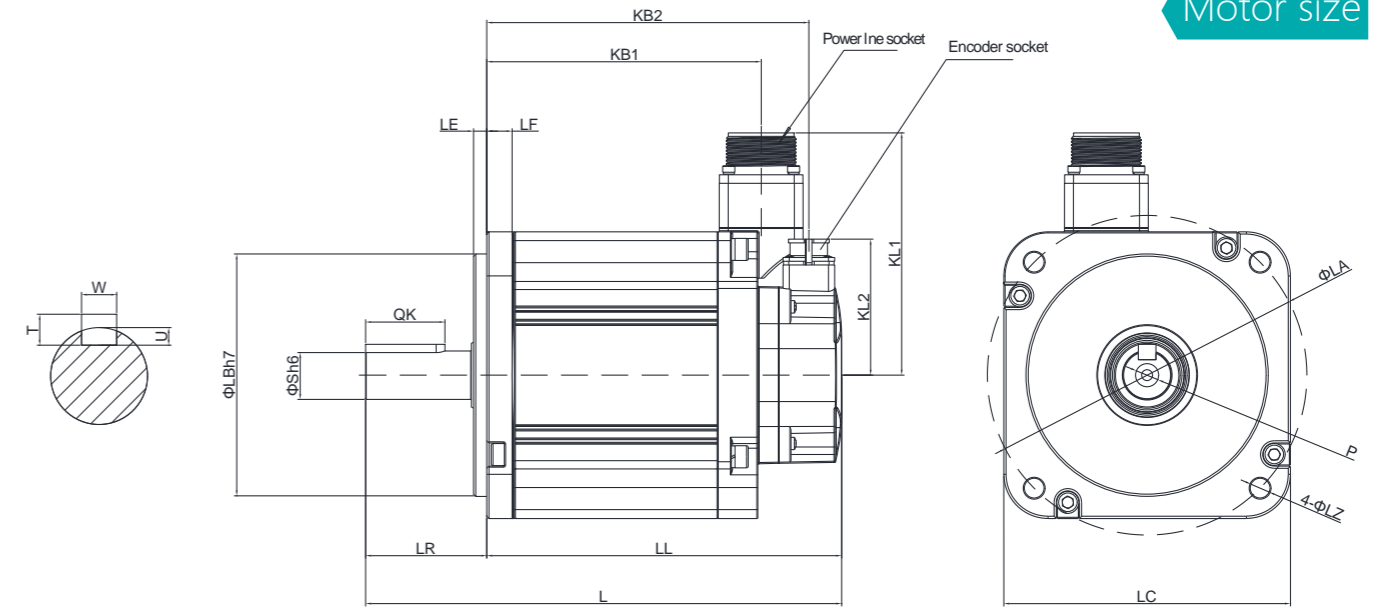

Power	EM3G-	L	LL	KB1	KB2	KL1	KL2	Flange Dimensions								S	P	key			
								LR	LE	LF	LC	LA	LB	LZ	QK			W	T	U	
0.85kW	09□	185(215)	131(161)	94.5	116(146)	112	60	55	6	12	130	145	110	9	22	M6×20	32	8	7	4	
1.3kW	13□	200(230)	146(176)	109.5	131(161)	112	60	55	6	12	130	145	110	9	22	M6×20	32	8	7	4	
1.8kW	18□	215(245)	161(191)	124.5	146(176)	112	60	55	6	12	130	145	110	9	22	M6×20	32	8	7	4	
2.9kW	29D	239(284)	160(205)	135.5(139.8)	145.5(190.2)	142	60	79	3.2	18	180	200	114.3	13.5	35	M12×25	65	10	8	5	
4.4kW	44D	258(303)	179(224)	154.5(158.8)	164.5(209.2)	142	60	79	3.2	18	180	200	114.3	13.5	35	M12×25	65	10	8	5	
5.5kW	55D	324(377)	221(264)	186.5(198.8)	196.5(249.2)	142	60	113	3.2	18	180	200	114.3	13.5	42	M16×32	96	12	10	5	
7.5kW	75D	360(413)	247(300)	222.5(234.8)	232.5(285.2)	142	60	113	3.2	18	180	200	114.3	13.5	42	M16×32	96	12	10	5	

Note: The values in parentheses represent the values of motors with brakes.

	200VAC			400VAC						
	09A	13A	18A	09D	13D	18D	29D	44D	55D	75D
EM3G-	09A	13A	18A	09D	13D	18D	29D	44D	55D	75D
Flange [mm]	130	130	130	130	130	130	180	180	180	180
Rated power [kW]	0.85	1.3	1.8	0.85	1.3	1.8	2.9	4.4	5.5	7.5
Rated speed[r/min]	1500	1500	1500	1500	1500	1500	1500	1500	1500	1500
Maximum speed [r/min]	3000	3000	3000	3000	3000	3000	3000	3000	3000	3000
Rated torque [N·m]	5.41	8.28	11.5	5.41	8.28	11.5	18.6	28.4	35.0	48.0
Maximum torque [N·m]	16.2	24.8	31.0	16.2	24.8	31.0	55.8	80.0	105	120
Rated current [Arms]	6.8	9.7	14.5	3.4	5.0	7.1	11.5	16.8	20.3	26.5
Maximum current [Arms]	22.6	29.7	42.0	10.9	15.6	21.2	37.0	49.5	64.0	70.0
Motor inertia [10 ⁻⁴ kg·m ²]	11.9(12.5)	17.3(17.9)	22.3(22.9)	11.9(12.5)	17.3(17.9)	22.3(22.9)	43.4(49.2)	58.8(64.6)	85.5(91.5)	117(123)
Allowable shaft end load	Radial[N]	490	686	980	490	686	980	1470	1470	1764
	Axial[N]	98	343	392	98	343	392	490	490	588
Brake specification	Rated voltage	24VDC	24VDC	24VDC	24VDC	24VDC	24VDC	24VDC	24VDC	24VDC
	Holding torque[N·m]	≥20	≥20	≥20	≥20	≥20	≥20	≥44	≥44	≥72
Weight[kg]	5.6(7.3)	7.0(8.7)	8.3(10.0)	5.6(7.3)	7.0(8.7)	8.3(10.0)	14.6(18.8)	17.6(21.8)	23.2(27.8)	29.0(33.6)

Note: The values in parentheses represent the values of motors with brakes.



Note: T represents a 17-bits absolute
L represents a 23-bits absolute

EM3L servo motor(1kW ~ 4kW)

Medium capacity | low speed | High inertia

Motor size

EM3L - 10 D L A 2 2 4

Rated output power Voltage grade encoder Design order Shaft end Optional Plug type

10	1.0kW	D	400VAC	T	17-bits absolute	A	-	2	Straight, with keys, Threaded	1	No oil seals, No brakes	4	Aviation Plug
20	2.0kW			L	23-bits absolute					2	With oil seal, No brakes		
30	3.0kW									3	No oil seals, With brake		
40	4.0kW									4	With oil seal, With brake		



Note: 1. Please refer to Model Comparison Table for details.
 2. Motor body heat resistance class: F
 3. Motor body protection mode: self-cooling, IP65

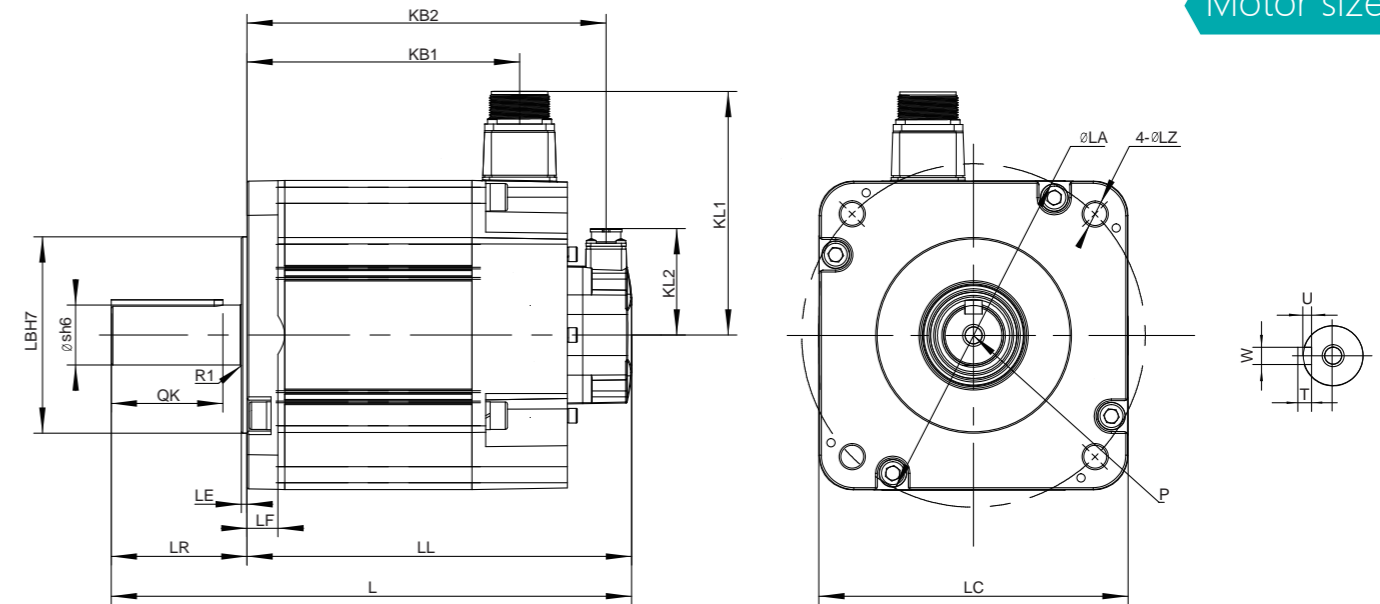

Power	EM3L-	L	LL	KB1	KB2	KL1	KL2	Flange Dimensions								S	P	key			
								LR	LE	LF	LC	LA	LB	LZ	OK			W	T	U	
1.0kW	10D	215(245)	161(191)	124.5(124.5)	146(176)	112	58.5	55	6	12	130	145	110	9	22	M6 × 20	36	8	7	4	
2.0kW	20D	258(303)	179(224)	154.5 (158.8)	164(209)	142	62	79	3.2	18	180	200	114.3	13.5	35	M12 × 25	65	10	8	5	
3.0kW	30D	290(343)	211(264)	186.5(198.8)	196(249)	142	62	79	3.2	18	180	200	114.3	13.5	35	M12 × 25	65	10	8	5	
4.0kW	40D	360(413)	247(300)	222.5(234.8)	232(285)	142	62	113	3.2	18	180	200	114.3	13.5	42	M16 × 32	96	12	8	5	

Note: The values in parentheses represent the values of motors with brakes.

		400VAC			
EM3L-		10D	20D	30D	40D
Flange [mm]		130	180	180	180
Rated power [kW]		1.0	2.0	3.0	4.0
Rated speed[r/min]		1000	1000	1000	1000
Maximum speed [r/min]		1500	1500	1500	1500
Rated torque [N·m]		9.55	19.1	28.7	38.2
Maximum torque [N·m]		31.0	69.0	105.0	120.0
Rated current [Arms]		3.1	5.2	8.6	10.9
Maximum current [Arms]		10.0	20.2	34.7	34.6
Motor inertia [10 ⁻⁴ kg · m ²]		22.3(22.9)	58.5(64.6)	85.5(91.5)	116.8(123)
Allowable shaft end load	Radial[N]	980	1470	1764	1764
	Axial[N]	392	490	588	588
Brake specification	Rated voltage	24VDC	24VDC	24VDC	24VDC
	Holding torque[N·m]	≥20	≥44	≥72	≥72
Weight[kg]		8.3(10.0)	17.6(21.8)	23.2(27.8)	29.0(33.6)

Note: The values in parentheses represent the values of motors with brakes.

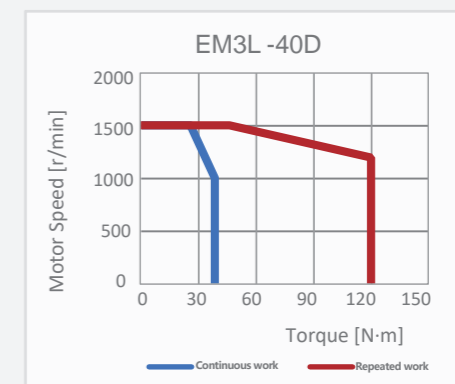
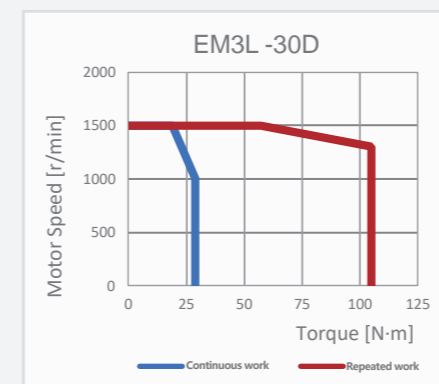
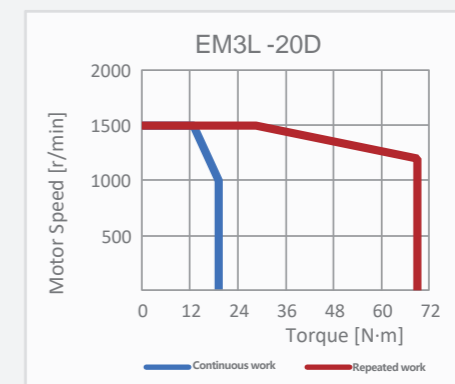
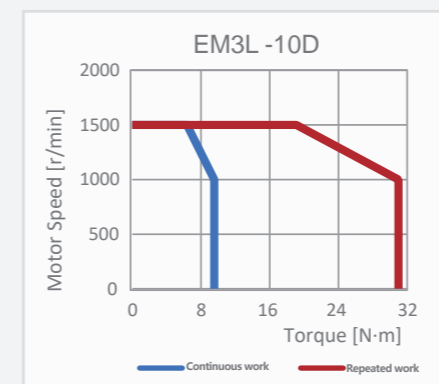

05 Model comparison table

EM3A | Low inertia | 3000 r/min

Power	Motor model	Brake	Connector	Flange	Trunnion	Drive	Input power	Power cable	Encoder cable
50W	EM3A-A5ALA221	-	Standard wire	40mm	Φ8	ED3L-A5A	Single phase AC 200V~240V	EC3P-N9118-□□	EC3S-A1124-□□ (Including battery)
	EM3A-A5ALA241	●						EC3P-B9118-□□	EC3S-I1124-□□ (No battery)
	EM3A-A5ALA222	-	Waterproof wire					EC3P-N9718-□□	EC3S-A1724-□□ (Including battery)
	EM3A-A5ALA242	●						EC3P-B9718-□□	EC3S-I1724-□□ (No battery)
100W	EM3A-01ATA221	-	Standard wire	40mm	Φ8	ED3L-01A	Single phase AC 200V~240V	EC3P-N9118-□□	EC3S-A1124-□□ (Including battery)
	EM3A-01ATA241	●						EC3P-B9118-□□	EC3S-I1124-□□ (No battery)
	EM3A-01ATA222	-	Waterproof wire					EC3P-N9718-□□	EC3S-A1724-□□ (Including battery)
	EM3A-01ATA242	●						EC3P-B9718-□□	EC3S-I1724-□□ (No battery)
	EM3A-01ALA221	-	Standard wire					EC3P-N9118-□□	EC3S-A1124-□□ (Including battery)
	EM3A-01ALA241	●						EC3P-B9118-□□	EC3S-I1124-□□ (No battery)
EM3A-01ALA222	-	Waterproof wire	EC3P-N9718-□□	EC3S-A1724-□□ (Including battery)					
EM3A-01ALA242	●		EC3P-B9718-□□	EC3S-I1724-□□ (No battery)					
200W	EM3A-02ATA221	-	Standard wire	60mm	Φ14	ED3L-02A	Single phase AC 200V~240V	EC3P-N9118-□□	EC3S-A1124-□□ (Including battery)
	EM3A-02ATA241	●						EC3P-B9118-□□	EC3S-I1124-□□ (No battery)
	EM3A-02ATA222	-	Waterproof wire					EC3P-N9718-□□	EC3S-A1724-□□ (Including battery)
	EM3A-02ATA242	●				EC3P-B9718-□□	EC3S-I1724-□□ (No battery)		
	EM3A-02ALA221	-	Standard wire			ED3L-0404A	Single phase / three phase AC 200V~240V	EC3P-N9118-□□	EC3S-A1124-□□ (Including battery)
	EM3A-02ALA241	●						EC3P-B9118-□□	EC3S-I1124-□□ (No battery)
EM3A-02ALA222	-	Waterproof wire	EC3P-N9718-□□	EC3S-A1724-□□ (Including battery)					
EM3A-02ALA242	●		EC3P-B9718-□□	EC3S-I1724-□□ (No battery)					
400W	EM3A-04ATA221	-	Standard wire	60mm	Φ14	ED3L-04A	Single phase AC 200V~240V	EC3P-N9118-□□	EC3S-A1124-□□ (Including battery)
	EM3A-04ATA241	●						EC3P-B9118-□□	EC3S-I1124-□□ (No battery)
	EM3A-04ATA222	-	Waterproof wire					EC3P-N9718-□□	EC3S-A1724-□□ (Including battery)
	EM3A-04ATA242	●				EC3P-B9718-□□	EC3S-I1724-□□ (No battery)		
	EM3A-04ALA221	-	Standard wire			ED3L-0404A	Single phase / three phase AC 200V~240V	EC3P-N9118-□□	EC3S-A1124-□□ (Including battery)
	EM3A-04ALA241	●						EC3P-B9118-□□	EC3S-I1124-□□ (No battery)
EM3A-04ALA222	-	Waterproof wire	EC3P-N9718-□□	EC3S-A1724-□□ (Including battery)					
EM3A-04ALA242	●		EC3P-B9718-□□	EC3S-I1724-□□ (No battery)					

Power	Motor model	Brake	Connector	Flange	Trunnion	Drive	Input power	Power cable	Encoder cable			
750W	EM3A-08ATA221	-	Standard wire	80mm	Φ19	ED3L-08A	Single phase / three phase AC 200V~240V	EC3P-N8118-□□	EC3S-A1124-□□ (Including battery)			
	EM3A-08ATA241	●						EC3P-B8118-□□	EC3S-I1124-□□ (No battery)			
	EM3A-08ATA222	-	Waterproof wire					EC3P-N8718-□□	EC3S-A1724-□□ (Including battery)			
	EM3A-08ATA242	●				EC3P-B8718-□□		EC3S-I1724-□□ (No battery)				
	EM3A-08ALA221	-	Standard wire			ED3L-1010A		Single phase / three phase AC 200V~240V	EC3P-N8118-□□	EC3S-A1124-□□ (Including battery)		
	EM3A-08ALA241	●							EC3P-B8118-□□	EC3S-I1124-□□ (No battery)		
EM3A-08ALA222	-	Waterproof wire	EC3P-N8718-□□	EC3S-A1724-□□ (Including battery)								
EM3A-08ALA242	●		EC3P-B8718-□□	EC3S-I1724-□□ (No battery)								
1.0kW	EM3A-10ATA221	-	Standard wire	80mm	Φ19	ED3L-10A	Single phase / three phase AC 200V~240V	EC3P-N8118-□□	EC3S-A1124-□□ (Including battery)			
	EM3A-10ATA241	●						EC3P-B8118-□□	EC3S-I1124-□□ (No battery)			
	EM3A-10ATA222	-	Waterproof wire					EC3P-N8718-□□	EC3S-A1724-□□ (Including battery)			
	EM3A-10ATA242	●				EC3P-B8718-□□		EC3S-I1724-□□ (No battery)				
	EM3A-10ALA221	-	Standard wire			ED3L-1010A		Single phase / three phase AC 200V~240V	EC3P-N8118-□□	EC3S-A1124-□□ (Including battery)		
	EM3A-10ALA241	●							EC3P-B8118-□□	EC3S-I1124-□□ (No battery)		
EM3A-10ALA222	-	Waterproof wire	EC3P-N8718-□□	EC3S-A1724-□□ (Including battery)								
EM3A-10ALA242	●		EC3P-B8718-□□	EC3S-I1724-□□ (No battery)								
1.5kW	EM3A-15ATB224	-	Aviation Plug	100mm	Φ24	ED3L-15A	Single phase / three phase AC 200V~240V	EC3P-N9314-□□	EC3S-A1924-□□ (Including battery)			
	EM3A-15ATB244	●						EC3P-B9314-□□				
	EM3A-15ALB224	-	Waterproof wire					EC3P-N9314-□□		EC3S-I1924-□□ (No battery)		
	EM3A-15ALB244	●				EC3P-B9314-□□						
	EM3A-15DTB224	-	Aviation Plug			100mm		Φ24		ED3L-15D	three phase AC 380V~440V	EC3P-N9314-□□
	EM3A-15DTB244	●										EC3P-B9314-□□
EM3A-15DLB224	-	Waterproof wire		EC3P-N9314-□□								
EM3A-15DLB244	●		EC3P-B9314-□□									
2.0kW	EM3A-20ATB224	-	Aviation Plug	100mm	Φ24	ED3L-20A	three phase AC 200V~240V	EC3P-N9314-□□	EC3S-A1924-□□ (Including battery)			
	EM3A-20ATB244	●						EC3P-B9314-□□				
	EM3A-20ALB224	-	Waterproof wire					EC3P-N9314-□□		EC3S-I1924-□□ (No battery)		
	EM3A-20ALB244	●				EC3P-B9314-□□						
	EM3A-20DTB224	-	Aviation Plug			100mm		Φ24		ED3L-20D	three phase AC 380V~440V	EC3P-N9314-□□
	EM3A-20DTB244	●										EC3P-B9314-□□
EM3A-20DLB224	-	Waterproof wire		EC3P-N9314-□□								
EM3A-20DLB244	●		EC3P-B9314-□□									
3.0kW	EM3A-30DTA224	-	Aviation Plug	130mm	Φ28	ED3L-30D	three phase AC 380V~440V	EC3P-N9314-□□	EC3S-A1924-□□ (Including battery)			
	EM3A-30DTA244	●						EC3P-B9314-□□				
	EM3A-30DLA224 *	-	Waterproof wire					EC3P-N9314-□□		EC3S-I1924-□□ (No battery)		
	EM3A-30DLA244 *	●				EC3P-B9314-□□						
4.0kW	EM3A-40DTA224	-	Aviation Plug	130mm	Φ28	ED3L-50D	three phase AC 380V~440V	EC3P-N9319-□□	EC3S-A1924-□□ (Including battery)			
	EM3A-40DTA244	●						EC3P-B9319-□□				
	EM3A-40DLA224 *	-	Waterproof wire					EC3P-N9319-□□		EC3S-I1924-□□ (No battery)		
	EM3A-40DLA244 *	●				EC3P-B9319-□□						
5.0kW	EM3A-50DTA224	-	Aviation Plug	130mm	Φ28	ED3L-50D	three phase AC 380V~440V	EC3P-N9319-□□	EC3S-A1924-□□ (Including battery)			
	EM3A-50DTA244	●						EC3P-B9319-□□				
	EM3A-50DLA224 *	-	Waterproof wire					EC3P-N9319-□□		EC3S-I1924-□□ (No battery)		
	EM3A-50DLA244 *	●				EC3P-B9319-□□						

EM3G | Medium inertia | 1500 r/min

Power	Motor model	Brake	Connector	Flange	Trunnion	Drive	Input power	Power cable	Encoder cable
850W	EM3G-09ATA224	-	Aviation Plug	130mm	Φ22	ED3L-10A ED3L-1010A	Single phase / three phase AC 200V~240V	EC3P-N9314-□□	EC3S-A1924-□□ (Including battery) EC3S-I1924-□□ (No battery)
	EM3G-09ATA244	●						EC3P-B9314-□□	
	EM3G-09ALA224	-	Aviation Plug					EC3P-N9314-□□	
	EM3G-09ALA244	●						EC3P-B9314-□□	
	EM3G-09DTA224	-	Aviation Plug			ED3L-10D	three phase AC 380V~440V	EC3P-N9314-□□	
	EM3G-09DTA244	●						EC3P-B9314-□□	
	EM3G-09DLA224	-						EC3P-N9314-□□	
	EM3G-09DLA244	●						EC3P-B9314-□□	
1.3kW	EM3G-13ATA224	-	Aviation Plug	130mm	Φ22	ED3L-15A	Single phase / three phase AC 200V~240V	EC3P-N9314-□□	EC3S-A1924-□□ (Including battery) EC3S-I1924-□□ (No battery)
	EM3G-13ATA244	●						EC3P-B9314-□□	
	EM3G-13ALA224	-	Aviation Plug					EC3P-N9314-□□	
	EM3G-13ALA244	●						EC3P-B9314-□□	
	EM3G-13DTA224	-	Aviation Plug			ED3L-15D	three phase AC 380V~440V	EC3P-N9314-□□	
	EM3G-13DTA244	●						EC3P-B9314-□□	
	EM3G-13DLA224	-						EC3P-N9314-□□	
	EM3G-13DLA244	●						EC3P-B9314-□□	
1.8kW	EM3G-18ATA224	-	Aviation Plug	130mm	Φ22	ED3L-20A	three phase AC 200V~240V	EC3P-N9314-□□	EC3S-A1924-□□ (Including battery) EC3S-I1924-□□ (No battery)
	EM3G-18ATA244	●						EC3P-B9314-□□	
	EM3G-18ALA224	-	Aviation Plug					EC3P-N9314-□□	
	EM3G-18ALA244	●						EC3P-B9314-□□	
	EM3G-18DTA224	-	Aviation Plug			ED3L-20D	three phase AC 380V~440V	EC3P-N9314-□□	
	EM3G-18DTA244	●						EC3P-B9314-□□	
	EM3G-18DLA224	-						EC3P-N9314-□□	
	EM3G-18DLA244	●						EC3P-B9314-□□	
2.9kW	EM3G-29DTA224	-	Aviation Plug	180mm	Φ35	ED3L-30D	three phase AC 380V~440V	EC3P-N8214-□□	EC3S-A1924-□□ (Including battery) EC3S-I1924-□□ (No battery)
	EM3G-29DTA244	●						EC3P-B8214-□□	
	EM3G-29DLA224	-						EC3P-N8214-□□	
	EM3G-29DLA244	●						EC3P-B8214-□□	
4.4kW	EM3G-44DTA224	-	Aviation Plug	180mm	Φ35	ED3L-50D	three phase AC 380V~440V	EC3P-N9212-□□	EC3S-A1924-□□ (Including battery) EC3S-I1924-□□ (No battery)
	EM3G-44DTA244	●						EC3P-B9212-□□	
	EM3G-44DLA224	-						EC3P-N9212-□□	
	EM3G-44DLA244	●						EC3P-B9212-□□	
5.5kW	EM3G-55DTA224	-	Aviation Plug	180mm	Φ42	ED3L-75D	three phase AC 380V~440V	EC3P-N9212-□□	EC3S-A1924-□□ (Including battery) EC3S-I1924-□□ (No battery)
	EM3G-55DTA244	●						EC3P-B9212-□□	
	EM3G-55DLA224	-						EC3P-N9212-□□	
	EM3G-55DLA244	●						EC3P-B9212-□□	
7.5kW	EM3G-75DTA224	-	Aviation Plug	180mm	Φ42	ED3L-75D	three phase AC 380V~440V	EC3P-N9211-□□	EC3S-A1924-□□ (Including battery) EC3S-I1924-□□ (No battery)
	EM3G-75DTA244	●						EC3P-B9211-□□	
	EM3G-75DLA224	-						EC3P-N9211-□□	
	EM3G-75DLA244	●						EC3P-B9211-□□	

EM3J | Medium inertia | 3000 r/min

Power	Motor model	Brake	Connector	Flange	Trunnion	Drive	Input power	Power cable	Encoder cable			
200W	EM3J-02ATA221	-	Standard wire	60mm	Φ14	ED3L-02A ED3L-0404A	Single phase 200V~240V	EC3P-N9118-□□	EC3S-A1124-□□ (Including battery)			
	EM3J-02ATA241	●						EC3P-B9118-□□	EC3S-I1124-□□ (No battery)			
	EM3J-02ATA222	-	Waterproof wire					EC3P-N9718-□□	EC3S-A1724-□□ (Including battery)			
	EM3J-02ATA242	●						EC3P-B9718-□□	EC3S-I1724-□□ (No battery)			
	EM3J-02ALA221	-	Standard wire					EC3P-N9118-□□	EC3S-A1124-□□ (Including battery)			
	EM3J-02ALA241	●				EC3P-B9118-□□	EC3S-I1124-□□ (No battery)					
	EM3J-02ALA222	-				Waterproof wire	EC3P-N9718-□□	EC3S-A1724-□□ (Including battery)				
	EM3J-02ALA242	●					EC3P-B9718-□□	EC3S-I1724-□□ (No battery)				
	400W	EM3J-04ATA221				-	Standard wire	60mm	Φ14	ED3L-04A ED3L-0404A	Single phase / three phase AC 200V~240V	EC3P-N9118-□□
		EM3J-04ATA241	●			EC3P-B9118-□□						EC3S-I1124-□□ (No battery)
EM3J-04ATA222		-	Waterproof wire	EC3P-N9718-□□	EC3S-A1724-□□ (Including battery)							
EM3J-04ATA242		●		EC3P-B9718-□□	EC3S-I1724-□□ (No battery)							
EM3J-04ALA221		-	Standard wire	EC3P-N9118-□□	EC3S-A1124-□□ (Including battery)							
EM3J-04ALA241		●		EC3P-B9118-□□	EC3S-I1124-□□ (No battery)							
EM3J-04ALA222		-		Waterproof wire	EC3P-N9718-□□	EC3S-A1724-□□ (Including battery)						
EM3J-04ALA242		●			EC3P-B9718-□□	EC3S-I1724-□□ (No battery)						
750W		EM3J-08ATA221		-	Standard wire	80mm	Φ19			ED3L-08A ED3L-1010A	Single phase / three phase AC 200V~240V	EC3P-N8118-□□
		EM3J-08ATA241	●	EC3P-B8118-□□								EC3S-I1124-□□ (No battery)
	EM3J-08ATA222	-	Waterproof wire	EC3P-N8718-□□	EC3S-A1724-□□ (Including battery)							
	EM3J-08ATA242	●		EC3P-B8718-□□	EC3S-I1724-□□ (No battery)							
	EM3J-08ALA221	-	Standard wire	EC3P-N8118-□□	EC3S-A1124-□□ (Including battery)							
	EM3J-08ALA241	●		EC3P-B8118-□□	EC3S-I1124-□□ (No battery)							
	EM3J-08ALA222	-		Waterproof wire	EC3P-N8718-□□			EC3S-A1724-□□ (Including battery)				
	EM3J-08ALA242	●			EC3P-B8718-□□			EC3S-I1724-□□ (No battery)				
	1.0kW	EM3J-10ATA221		-	Standard wire			80mm	Φ19	ED3L-10A ED3L-1010A	Single phase / three phase AC 200V~240V	EC3P-N8118-□□
		EM3J-10ATA241	●	EC3P-B8118-□□								
EM3J-10ALA221		-	EC3P-N8118-□□									
EM3J-10ALA241		●	EC3P-B8118-□□									
EM3J-10DTA221		-	Standard wire	ED3L-10D	three phase AC 380V~440V	EC3P-N8118-□□	EC3S-A1124-□□ (Including battery) EC3S-I1124-□□ (No battery)					
EM3J-10DTA241		●				EC3P-B8118-□□						
EM3J-10DLA221		-				EC3P-N8118-□□						
EM3J-10DLA241		●				EC3P-B8118-□□						

EM3L | High inertia | 1000 r/min

Power	Motor model	Brake	Connector	Flange	Trunnion	Drive	Input power	Power cable	Encoder cable
1kW	EM3L-10DLA224	-	Aviation Plug	130mm	φ22	ED3L-10D	Three phase AC 380V~440V	EC3P-N9314-□□	EC3S-A1924-□□ (Including battery)
	EM3L-10DLA244	●						EC3P-B9314-□□	EC3S-I1924-□□ (No battery)
	EM3L-10DTA224	-	Aviation Plug					EC3P-N9314-□□	EC3S-A1924-□□ (Including battery)
	EM3L-10DTA244	●						EC3P-B9314-□□	EC3S-I1924-□□ (No battery)
2kW	EM3L-20DLA224	-	Aviation Plug	180mm	φ35	ED3L-20D	Three phase AC 380V~440V	EC3P-N9212-□□	EC3S-A1924-□□ (Including battery)
	EM3L-20DLA244	●						EC3P-B9212-□□	EC3S-I1924-□□ (No battery)
	EM3L-20DTA224	-	Aviation Plug					EC3P-N9212-□□	EC3S-A1924-□□ (Including battery)
	EM3L-20DTA244	●						EC3P-B9212-□□	EC3S-I1924-□□ (No battery)
3kW	EM3L-30DLA224	-	Aviation Plug	180mm	φ35	ED3L-30D	Three phase AC 380V~440V	EC3P-N9212-□□	EC3S-A1924-□□ (Including battery)
	EM3L-30DLA244	●						EC3P-B9212-□□	EC3S-I1924-□□ (No battery)
	EM3L-30DTA224	-	Aviation Plug					EC3P-N9212-□□	EC3S-A1924-□□ (Including battery)
	EM3L-30DTA244	●						EC3P-B9212-□□	EC3S-I1924-□□ (No battery)
4kW	EM3L-40DLA224	-	Aviation Plug	180mm	φ42	ED3L-50D	Three phase AC 380V~440V	EC3P-N9211-□□	EC3S-A1924-□□ (Including battery)
	EM3L-40DLA244	●						EC3P-B9211-□□	EC3S-I1924-□□ (No battery)
	EM3L-40DTA224	-	Aviation Plug					EC3P-N9211-□□	EC3S-A1924-□□ (Including battery)
	EM3L-40DTA244	●						EC3P-B9211-□□	EC3S-I1924-□□ (No battery)

- Note: 1. "-" Represents a model without brakes, ● indicates a model with brakes.
 2. Encoder cable with battery is selected by default. If there is no absolute demand, You can select the battery free cable model.
 3. □□ in the cable model indicates the length. Standard length: 1M5(1.5m), 03(3m), 05(5m), 08(8m), 10(10m), 12(12m), 15(15m), 20(20m). Flexible cables are optional, marked with -Rx. For example, the model of EC3P-N9118-03 flexible cable is EC3P-N9118-RX-03.
 Example: EC3P-N9118-03 Shielded cable model: EC3P-N9118-SS-03.
 4. The selection of I / O plug is determined by the driver: EtherCAT / PN driver product: 26 pin plug (sm-26J). Pulse driver products :50-pin plug (SM-50J).
 5. Optional debugging cable model: USB communication cable MINI USB- double magnetic ring shielding -1M5.
 6. Optional communication cable model: DK-HSB-RJ45-CAT5E-XX.

06 Accessories

Encoder cable

EC3S-I1124-□□ (Incremental)

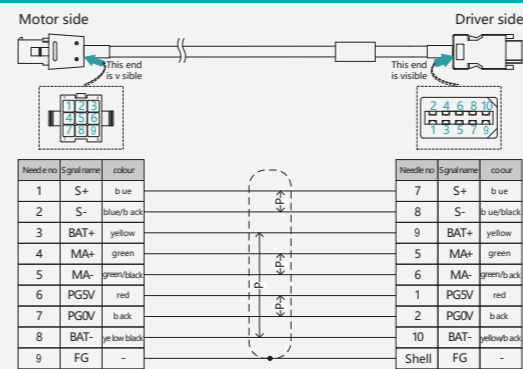

EC3S-A1124-□□ (Absolute)

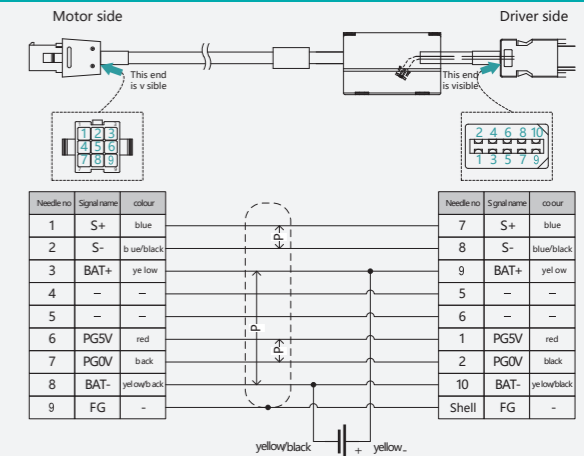

EC3S-I1724-□□ (Incremental)

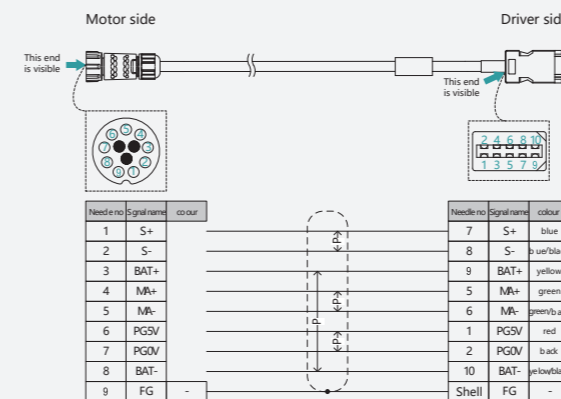

EC3S-A1724-□□ (Absolute)

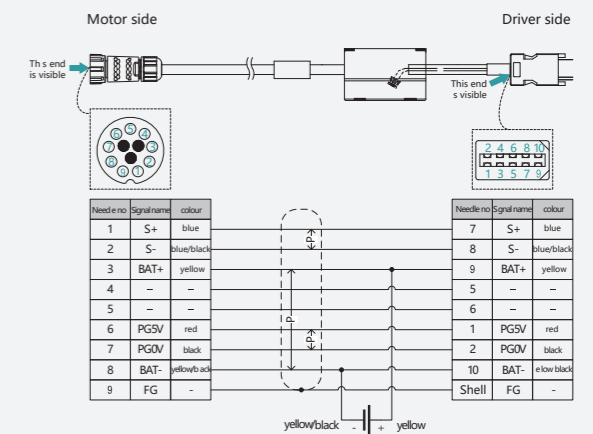

EC3S-I1924-□□ (Incremental)

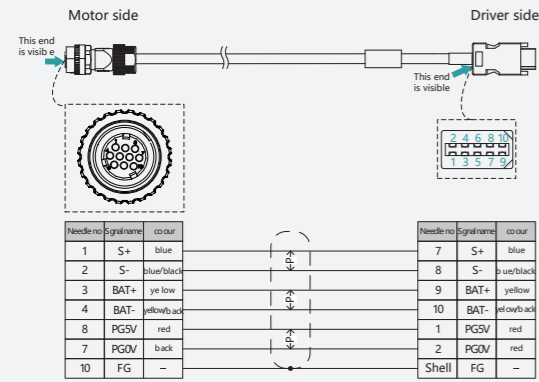

EC3S-A1924-□□ (Absolute)

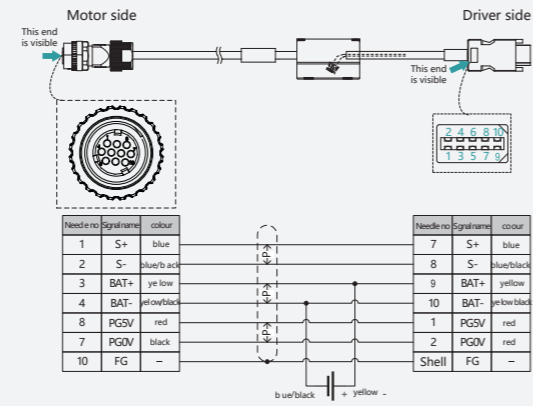

EC3P-N9718-□□ (No brake,)

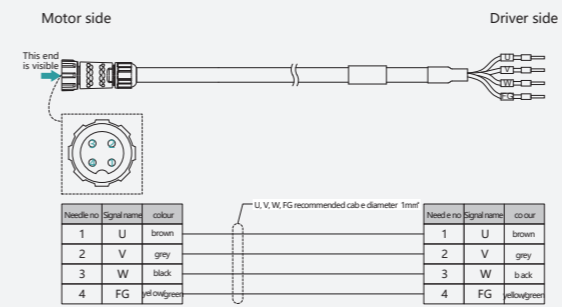

EC3P-B9718-□□ (With brake,)

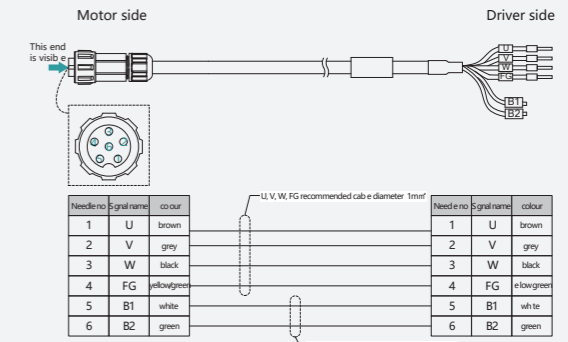

Power cable

EC3P-N9118-□□ (No brake)

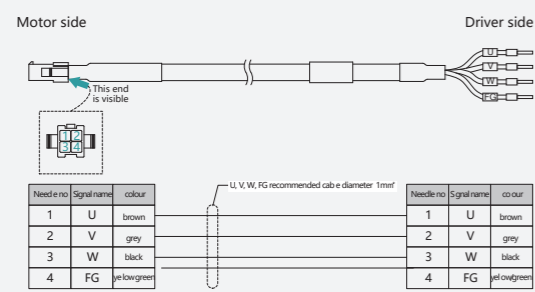

EC3P-B9118-□□ (With brake)

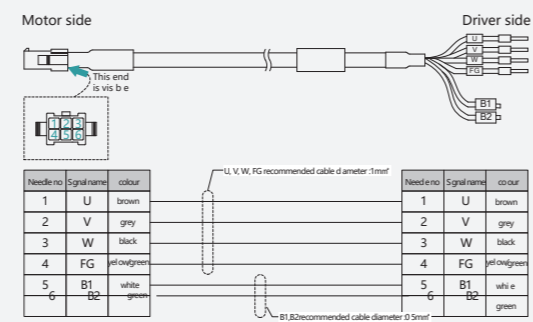

EC3P-N8118-□□ (No brake)

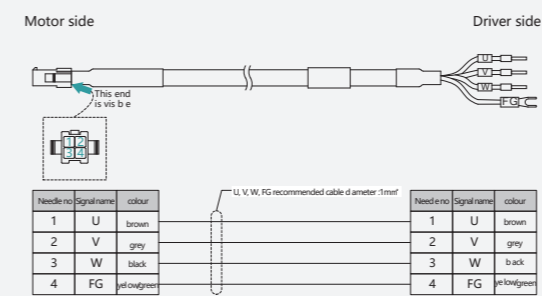

EC3P-B8118-□□ (With brake)

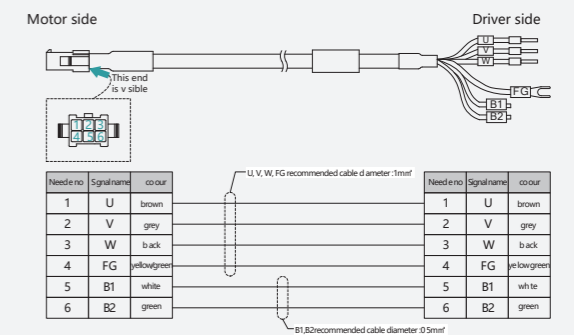

Power cable

EC3P-N8718-□□ (No brake)

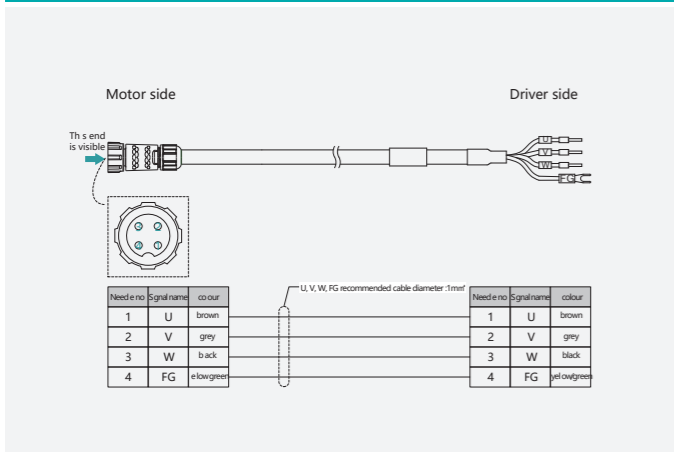

EC3P-B8718-□□ (With brake)

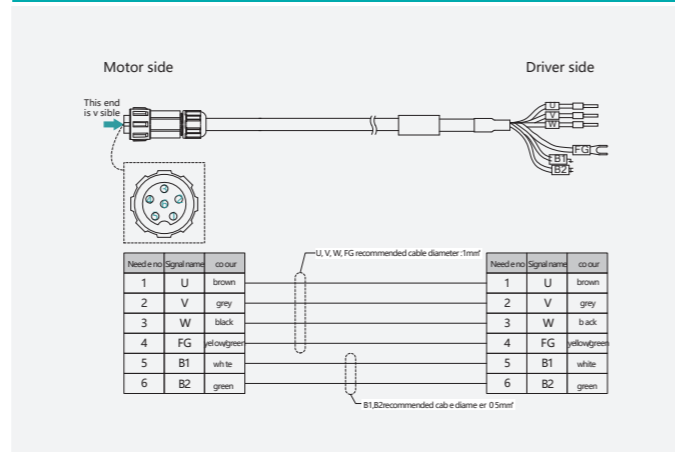

Power cable

EC3P-N8214-□□ (No brake)

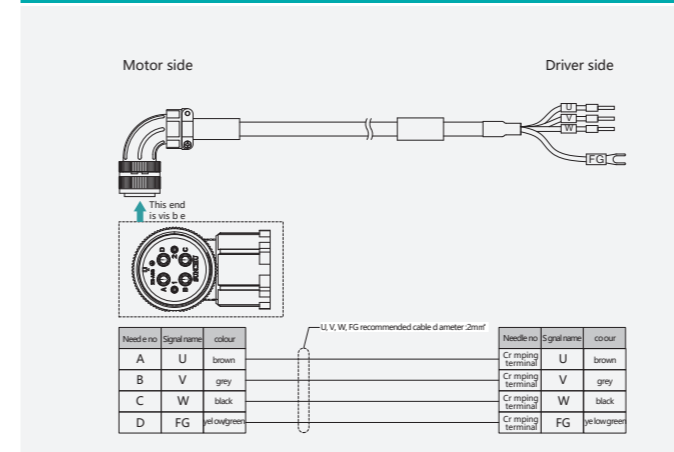

EC3P-B8214-□□ (With brake)

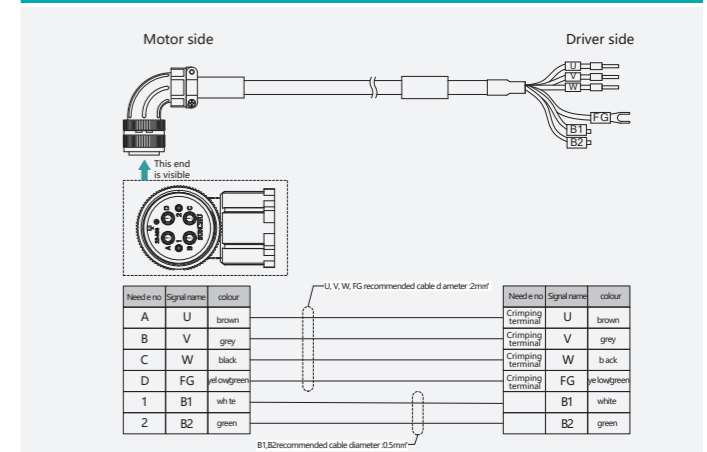

EC3P-N9314-□□ (No brake)

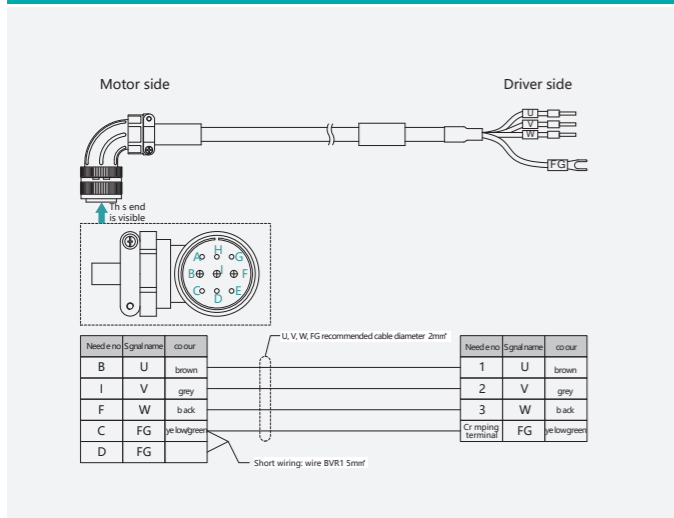

EC3P-B9314-□□ (With brake)

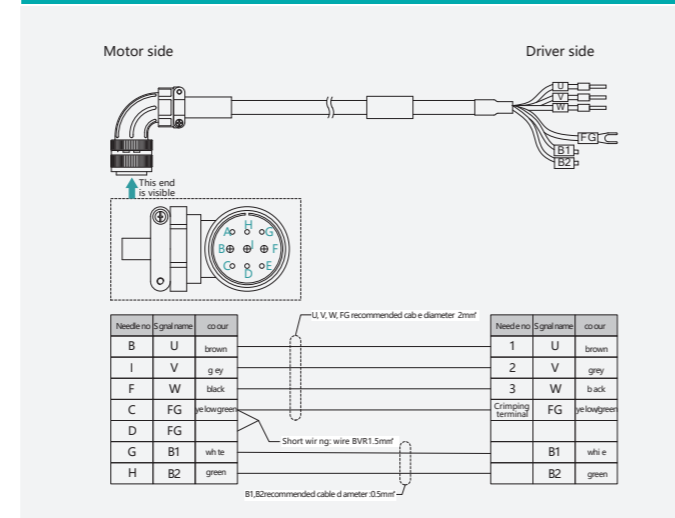

EC3P-N9212-□□ (No brake)

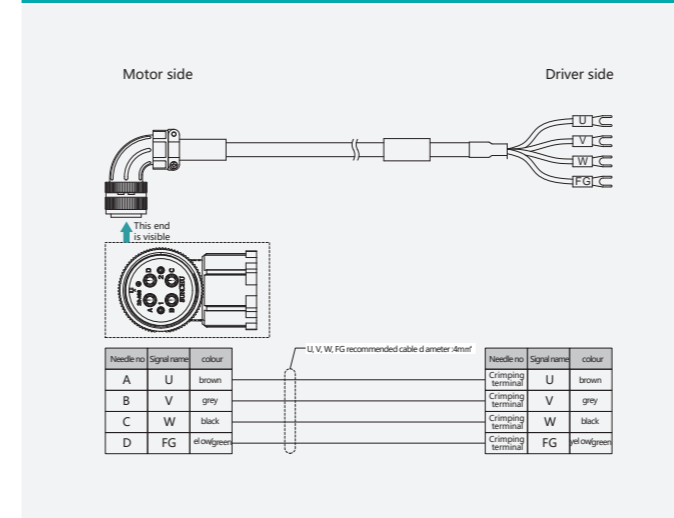

EC3P-B9212-□□ (With brake)

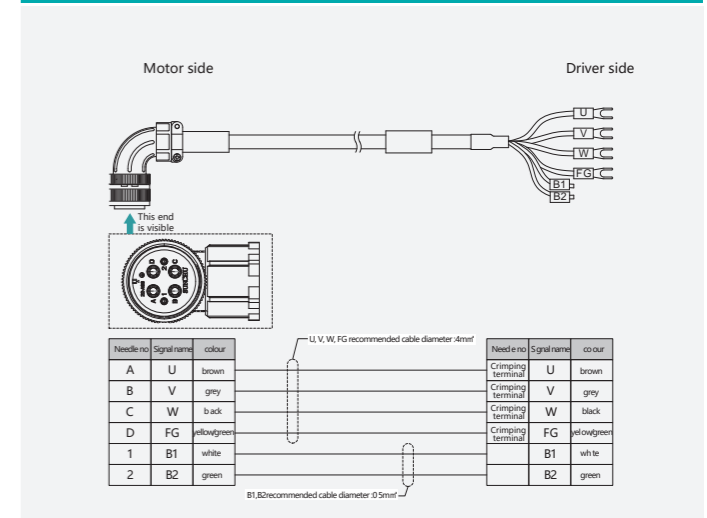

EC3P-N9319-□□ (No brake)

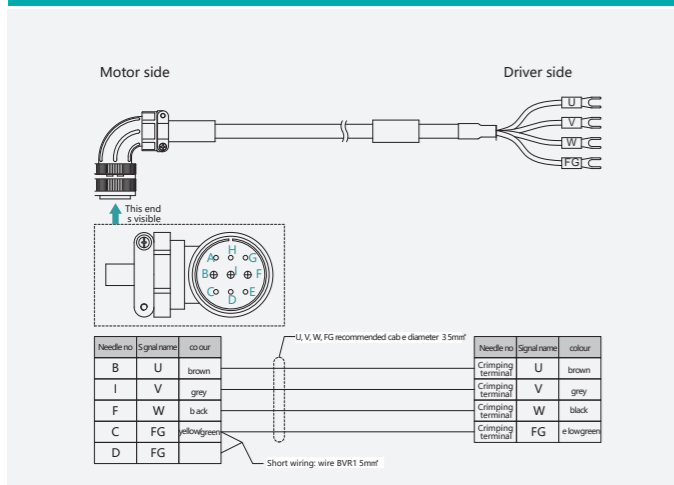

EC3P-B9319-□□ (With brake)

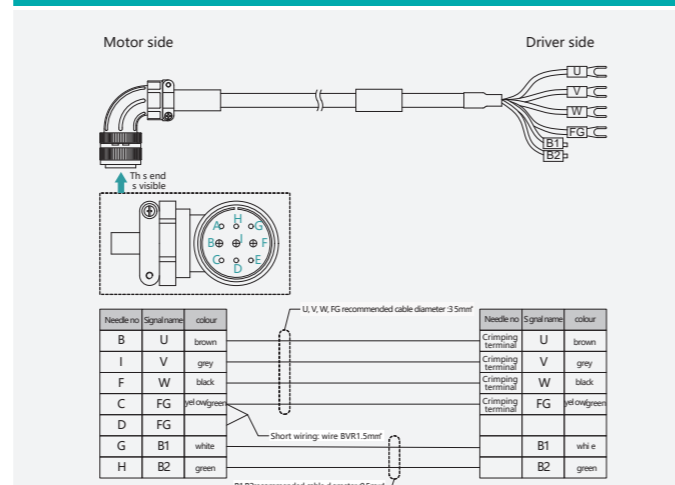

EC3P-N9211-□□ (No brake)

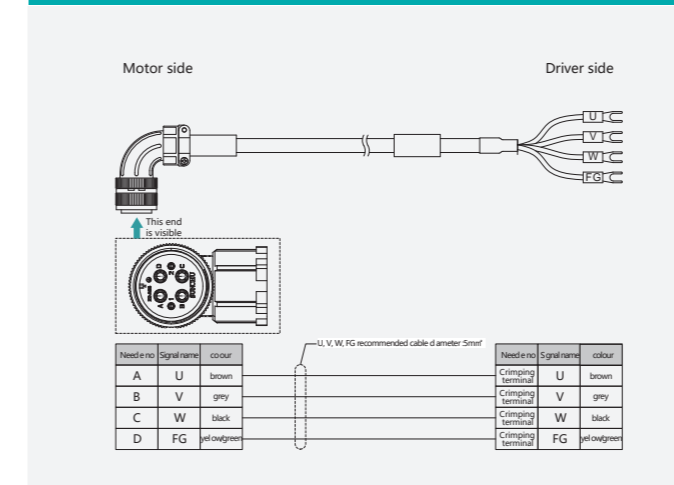



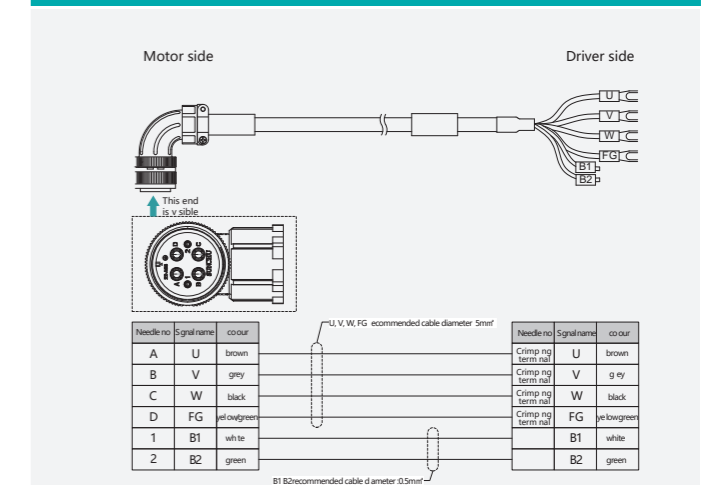

EC3P-B9211-□□ (With brake)

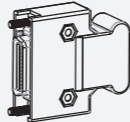
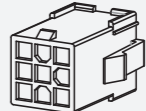
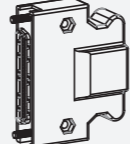
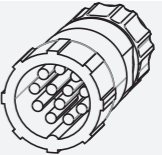
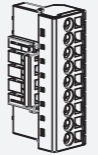
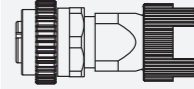
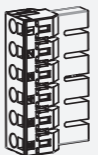
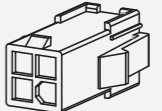
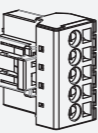

Peripheral specifications

Driver	Main circuit voltage	Built-in regenerative resistor specification	Minimum external regenerative resistance	Minimum current of circuit breaker
ED3L-A5A	Single phase AC 200V~240V	-	45Ω	4A (Single phase)
ED3L-01A	Single phase AC 200V~240V	-	45Ω	4A (Single phase)
ED3L-02A	Single phase AC 200V~240V	-	45Ω	4A (Single phase)
ED3L-04A	Single phase AC 200V~240V	-	45Ω	4A (Single phase)
ED3L-08A	Single phase/three phase AC 200V~240V	50Ω / 60W	25Ω	10A (Single phase) / 6A (three phase)
ED3L-10A	Single phase/three phase AC 200V~240V	50Ω / 60W	25Ω	16A (Single phase) / 6A (three phase)
ED3L-15A	Single phase/three phase AC 200V~240V	40Ω / 80W	25Ω	20A (Single phase) / 16A (three phase)
ED3L-20A	three phase AC 200V~240V	40Ω / 80W	25Ω	16A (three phase)
ED3L-10D	three phase AC 380V~440V	100Ω / 80W	65Ω	4A (three phase)
ED3L-15D	three phase AC 380V~440V	100Ω / 80W	65Ω	6A (three phase)
ED3L-20D	three phase AC 380V~440V	50Ω / 80W	40Ω	10A (three phase)
ED3L-30D	three phase AC 380V~440V	50Ω / 80W	40Ω	16A (three phase)
ED3L-50D	three phase AC 380V~440V	35Ω / 80W	20Ω	20A (three phase)
ED3L-75D	three phase AC 380V~440V	35Ω / 80W	20Ω	25A (three phase)
ED3L-0404A	Single phase/three phase AC 200V~240V	50Ω / 60W	45Ω	10A (Single phase) / 6A (three phase)
ED3L-1010A	Single phase/three phase AC 200V~240V	40Ω / 80W	25Ω	20A (Single phase) / 16A (three phase)

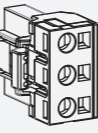
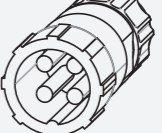
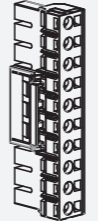
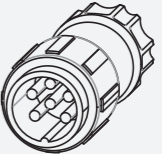
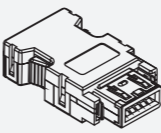
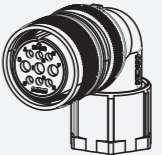
Other accessories

Servo drive side			Servo motor side		
Name	Illustration	Involving	Name	Illustration	Involving
IO plug SM-26J		ED3L bus driver (EtherCAT or Profinet)	Encoder plug (Standard wire)		EM3A motor (0.05kW ~ 1kW) EM3J motor EC3S-I1124-XX EC3S-A1124-XX
IO plug SM-50J		ED3L pulse driver	Encoder plug (Waterproof wire)		EM3A motor (0.05kW ~ 1kW) EM3J motor EC3S-I1724-XX EC3S-A1724-XX
Main circuit terminal Straight type, 9 pin, 10A		ED3L driver (200VAC, 0.05kW ~ 0.4kW)	Encoder plug (Straight type, 10pin, 3A)		EM3A motor (1.5kW ~ 5kW) EM3G motor EC3S-A1924-XX EC3S-I1924-XX
Main circuit terminal Straight type, 6pin, 20A		ED3L driver (200VAC, 0.75kW ~ 2kW)	Motor power plug (No brake, wire)		EM3A motor (0.05kW ~ 1kW) EM3J motor EC3P-N9118-XX EC3P-N8118-XX
Control loop terminal Straight type, 5pin, 14.5A		ED3L driver (200VAC, 0.75kW ~ 2kW)	Motor power plug (With brake, wire)		EM3A motor (0.05kW ~ 1kW) EM3J motor EC3P-B9118-XX EC3P-B8118-XX
Motor power terminal Straight type, 3pin, 20A		ED3L driver (0.75kW ~ 3kW)	Motor power plug (No brake, Waterproof wire)		EM3A motor (0.05kW ~ 1kW) EM3J motor EC3P-N9718-XX EC3P-N8718-XX
Main loop terminal Straight type, 10pin, 32A		ED3L driver (400VAC, 1kW ~ 3kW)	Motor power plug (With brake, Waterproof wire)		EM3A motor (0.05kW ~ 1kW) EM3J motor EC3P-B9718-XX EC3P-B8718-XX
Encoder plug (SM-10P-B)		All drives	Motor power plug (Bending type, 9pin, 13A+23A)		EM3G motor (0.85kW ~ 1.8kW) EM3A motor (1.5kW ~ 5.0kW) EC3P-□9314-XX EC3P-□9319-XX
			Motor power plug (Bending type, 6pin, 13A+46A)		EM3G motor (2.9kW ~ 7.5kW) EC3P-□8214-XX EC3P-□9212-XX EC3P-□9211-XX