

JWB

Ball Screw Jack

Contents

Product Description	001
Specifications	001
Sample Part Number	002
Application example	009
Dimensions	010



Product Description

JWB(General ball screw)

HIGH SPEED HIGH FREQUENCY

JWB(General ball screw) is suitable for high speed, high frequency and excellent performance.

Main components: Precision ball screw pair and high precision worm-gears pair.

- 1) High efficiency
Rolling friction improve efficiency greatly, only a little drive power can generate great thrust force.
- 2) High speed
Rolling friction speed up travel of screw easily.
- 3) Lifetime longer
High precision ball screw can make JWB's lifetime longer by 3 times comparing with JWB.

Specifications

JWB(General ball screw) basic parameter table:

Type		JWB010	JWB025	JWB050	JWB100	JWB150	JWB200	JWB300	JWB500	
Maximal load	(kN)	9.8	24.5	49.0	98.0	147	196	294	490	
Outer diameter of screw	(mm)	20	25	40	50	55	65	80	100	
Small diameter of screw	d (mm)	17.5	21.4	31.3	39.1	43.1	55.7	74.8	87	
Pitch of screw	L1 (mm)	5	8	10	12	12	12	16	20	
Ratio	i	H Speed	5	6	6	8	8	8	10 ^{2/3}	10 ^{2/3}
	L Speed	20	24	24	24	24	24	32	32	
Integrated efficiency %	η	H Speed	61	62	64	63	63	62	56	60
	L Speed	34	35	39	43	43	41	34	38	
Permissible output maximal power	(kw)	H Speed	0.54	1.3	2.2	3.6	4.0	5.5	8.9	13.3
	L Speed	0.27	0.63	1.0	1.9	2.1	2.8	4.1	6.5	
No-load torque	To (N · m)	0.29	0.62	1.37	1.96	2.65	3.92	9.81	19.6	
Keeping torque	(N · m)	H Speed	1.27	4.31	10.78	19.6	39.2	51.0	68.6	140.1
	L Speed	0.26	0.91	2.4	5.8	11.8	15.0	19.5	41.2	
Permissible torque of input shaft	(N · m)	19.6	49.0	153.9	292.0	292.0	292.0	735.0	1372.0	
Required torque of input shaft at maximal load	(N · m)	H Speed	2.8	9.0	21.5	39.1	77.0	104.5	169.6	317.5
	L Speed	1.4	4.3	9.6	20.4	39.6	54.2	98.5	177.9	
Axial displacement of screw, when input shaft rotate a circle.	(mm)	H Speed	1	1.33	1.67	1.5	1.5	1.5	1.5	1.88
	L Speed	0.25	0.33	0.42	0.5	0.5	0.5	0.5	0.63	
Permissible rotational speed of screw shaft at maximal loading	(rpm)	H Speed	1500	1400	1000	890	500	500	500	400
	L Speed	1500	1400	1000	890	500	500	400	350	
Rotational torque of screw at maximal load	(N · m)	8.7	34.7	86.7	208.2	416.3	555.1	1040.9	2081.7	

* Permissible torque of shaft of reducer.

** Include torque under the condition of no-load operating.

Sample Part Number

Illustration of types:

Plain mode and Mode with anti-rotation device:

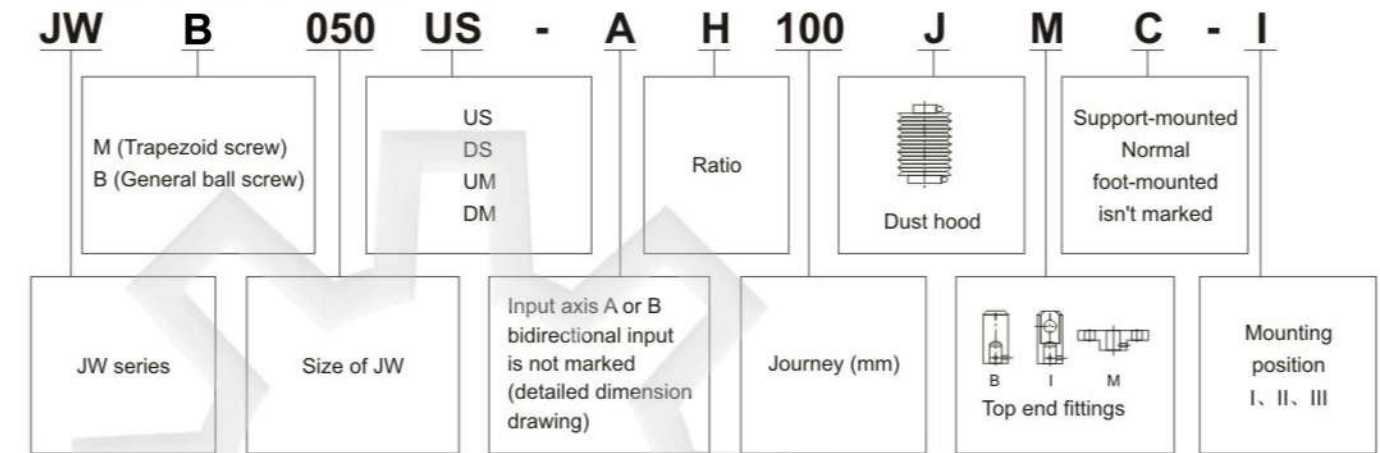

Plain mode (US, DS)

Worm wheel rotating, threaded spindles travel up and down.

Ordinary mounting mode is applied here,

US: UPRISE DS: DROP

* Select US or DS according to the load and mounting positions.

* Anti-rotation measures must be taken because torque on screw will be caused when screw traveling up and down.

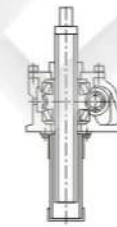

US

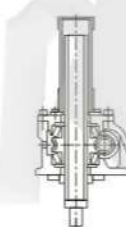

DS



US

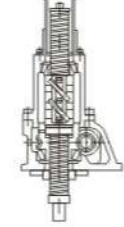

DS

With Anti-rotation device.

UM: UPRISE DM: DROP

* No rotation of screw, which only travel up and down.

* Select UM or DM according to the load and mounting positions.

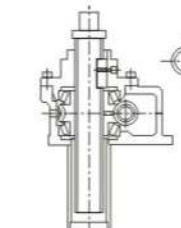

(JWM100-JWM200)
UM

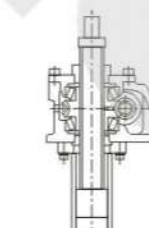

(JWM010-JWM050)(JWB010-JWB200)
DM

Mounting position

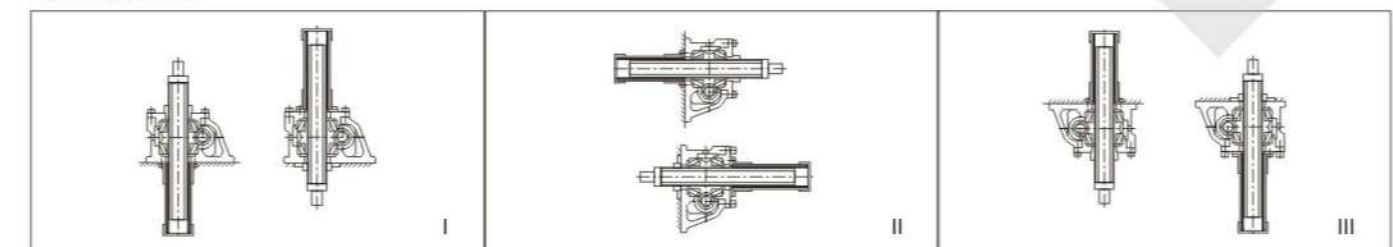

Note: Selecting mounting position III, the quality of bolt on housing feet reaches 10.9.

Sample Part Number

Illustration of type with traveling nut

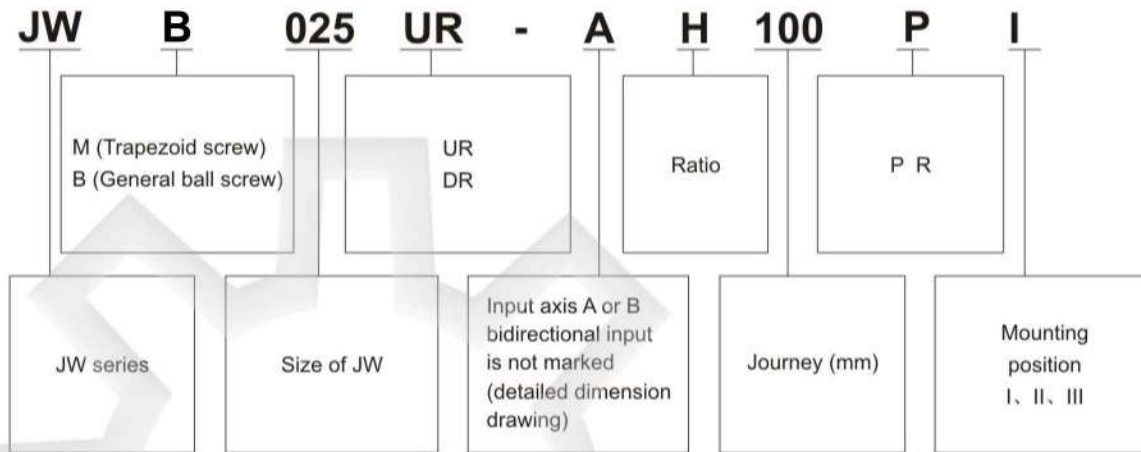

JW with Traveling nut

In general, Jack need enough space for screw's traveling journey and dust-hood.

Using traveling nut can help jack realize longer traveling journey in limited space.

The top end fittings are column, it can be a supporting point for a good transmission effect when a long traveling journey is selected.

UR: UPRISE DR: DROP

Select UR or DR according to the load and mounting positions.

Mounting direction of traveling nut (P, R)

The mounting direction of traveling nut should be signed on drawing when selecting types.

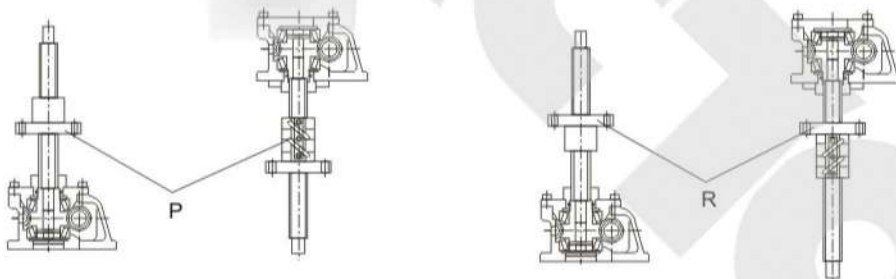

Mounting position of Jack (I, II, III)

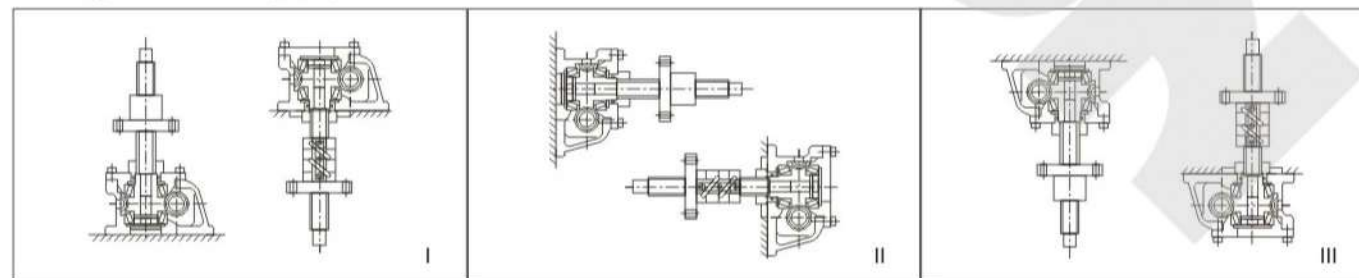

Note: Selecting mounting position III, the quality of bolt on housing feet reaches 10.9.



Sample Part Number

Note:

- 1) Select a Jack with sufficient capacity according to safety factor, service journey and stability. And static load, dynamic load and shock load must be lower than permissible maximum load.
- 2) Please note that rotation speed of screw must match load, permissible maximum load, permissible maximum outer load, and permissible rotation speed of screw must be verified. If these figures exceed that of products, jacks will be damaged greatly.
- 3) The surface temperature will be limited in -15° ~80° when jack working to ensure the temperature of traveling nuts in -15° ~80° .
- 4) Maximum input speed is 1500r/min.
- 5) JWM and JWB aren't suitable for continuous operation,
Jack Duty(%ED)
JWM duty(%ED) cannot exceed 20%ED,
JWB duty(%ED) cannot exceed 30%ED,

Duty %ED=
$$\frac{\text{jack operating time(lift \& lower cycle)}}{\text{Elapsed cycle time}} \times 100\%$$
- 6) When several Jacks are connected on the same axial line, the loaded torque with each Jack must be verified and limited within permissible input torque.
- 7) Starting torque must be 200% of service torque.
- 8) At below 0° ambient temperature, changed, adhesion of lubrication will lower Jack's efficiency so that sufficient drive is necessary.
- 9) JWM has self-lock function, but an Extra braking device or drive source with braking device is necessary to be equipped because self-lock will be of mal-function When Jack is loaded a heavy shock.
JWB has no self-lock function, to avoid backspin of screw under axial load and its weight, a braking device or drive source with braking device is necessary to be equipped and braking torque must be larger than operating torque of jack.

10) Jack's operating conditions

Working Location	Indoor location without rainwater
Ambient Air	Normal
Ambient Temperature	-15°C~40°C
Relative Humidity	Less than 85%

- 11) When working in dusty space, Jack must be equipped with elastic dust-hood on screw; in open air, shield must be equipped to prevent exposure to wind and rain.
- 12) When working, Jack cannot be forced to stop, or it will be damaged seriously.
- 13) Under load, don't change motor drive mode into manual drive, or which will cause backspin of screw and cause great danger.

How to select type:

Determine Jack's type:

calculate total equivalent load Ws (N):

$$W_s = W_{max} \times f_1$$

Service factor for driven machine (f1):

Load character	Example	Factor for driven machine (f1)
shockless load & small inertia load	Switch, valve transmission belt swithing device	1.0~1.3
moderate shock & moderate inertia	All kinds of moving devices, all kinds of elevators	1.3~1.5
heavy shock & large inertia	Carrying something by trolley; to keep the position of idling gear	1.5~3.0

Calculate equivalent load of single Jack,

$$W = \frac{WS}{\text{Number} \times \text{Linkage factor (fd)}}$$



Sample Part Number

Linkage factor(fd):

Number of linkage jack	1	2	3	4	5-8
Linkage factor	1	0.95	0.9	0.85	0.8

Temporarily determine Jack type:

Temporarily determine Jack type after taking full consideration of load, speed, journey, efficiency and drive source. Determine JW type according to service journey, ambient conditions, connection mode of end-fittings.

Verify input power

If required input power under load exceeds permissible maximum input power, please select larger type or lower the speed of screw rotation.

Calculation of required input power under load:

Required rotation speed of input shaft	n1 (r/min)	$n1 = \frac{V}{L1} \times i$
Required torque of input shaft	T1 (N · m)	$T1 = \frac{W \times L1}{2 \pi \times i \times \eta} + T0$
Required input power	P1 (kW)	$P1 = \frac{T1 \times n1}{9550}$

V: linear speed of screw mm/min L: Pitch of screw (m)
 i: ratio W: equivalent load of single jack π: pi
 η: Integrated efficiency T0: No-load torque (Nm)
 (L1, i, η, T0 refer to basic parameter table)

Verify the stability of screw:

Please verify the stability of screw under axial load, larger type should be used when load exceed the critical load. The formula to calculate the critical load as follows:

$$P_{CR} = fm \times \left(\frac{d^2}{L_s}\right)^2 \quad \text{ensure} \quad P_{CR} > W \times SF \quad (SF=4)$$

Pcr: Critical load (N)
 d: small diameter of screw end (mm)(refer to basic parameter table)
 fm: support factor
 La: distance between load-supporting point and mounting point as drawing.
 W: equivalent load of single jack (N)
 SF: safety factor (SF=4 as usual)

Verifying the stability of screw, the values of La and fm as follows,

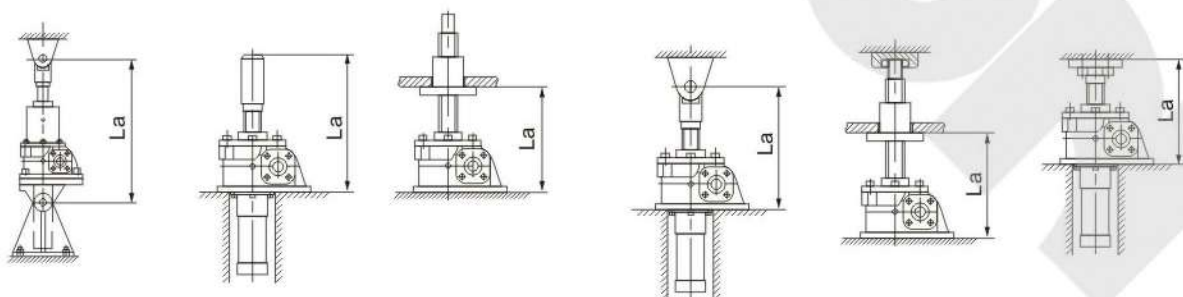

support at both ends fm=10×10⁴ Foot-mounted & movable shaft end fm=2.5×10⁴ Foot-mounted & shaft end supporting or fixed fm=20×10⁴

Verifying critical rotation speed:

Using traveling nut, the rotation speed of screw must be lower than critical speed, if no, please select larger type and calculate again.



Sample Part Number

$$n_c = \frac{96 \times fn \times d \times 10^6}{L_b^2} \quad n_s = \frac{n1}{i}$$

n_c: Permissible rotation speed of screw
 n_s: Rotational speed of screw
 d: Small diameter of screw (refer to basic parameter table)
 n1: Rotational speed of input shaft
 fn: Length factor
 i: ratio
 Lb: Distance between both supporting face

Verifying the rotation speed of screw, the values of Lb and fn as follows,

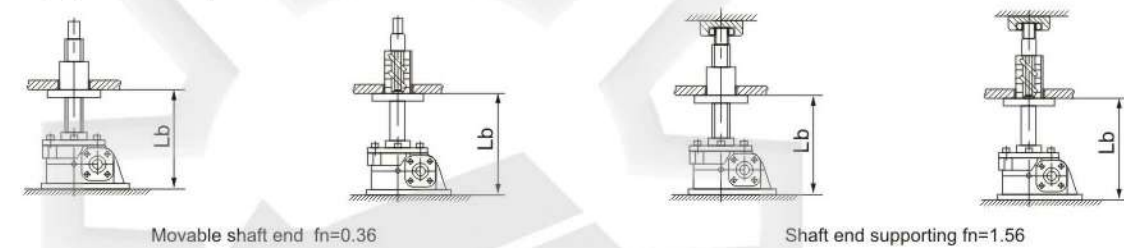

Ensure: n_c > n_s

Example for calculation:

Take JWM200UR-H1200PI as example, n1=1200r/min, connecting mode of top-end : I, we can know d=49.3, Lb=1437 referring to dimension and transmission capacity table.

$$n_s = \frac{n1}{i} = \frac{1200}{8} = 150r/min$$

$$n_c = \frac{96 \times fn \times d \times 10^6}{L_b^2} = \frac{96 \times 1.56 \times 49.3 \times 10^6}{(1437)^2} = 3575r/min$$

n_c=3575r/min > n_s=150r/min.....ok.

When there is radial load, please add guiding device.

JWM Permitted radial load Fr(N):

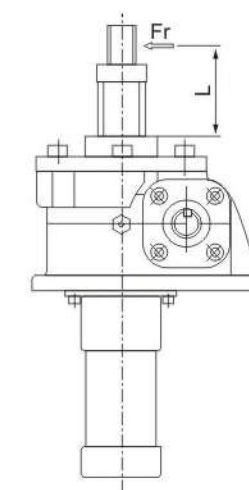

Fr(N) Type L(mm)	010	025	050	100	150	200	300	500	750	1000
100	318	57	2500	4010	4610	8210	38200	85300	73500	186200
200	159	290	1250	2010	2300	4110	23000	50400	56800	145000
300	106	190	830	1340	1540	2740	15300	33600	46100	104700
400	79	140	620	1000	1150	2050	11400	25200	39300	78500
500	64	110	500	800	920	1640	9100	20200	33900	62800
600	53	100	420	670	770	1370	7600	16800	29900	52300
700	51	90	360	570	660	1170	6500	14400	26700	44800
800	48	90	310	500	580	1030	5700	12600	24100	39200
900	45	90	280	450	510	910	5000	11200	22000	34800
1000	42	90	250	400	460	820	4500	10100	20200	31300



Sample Part Number

When operating radial load exceeds critical radial load, please add guiding device, for example,

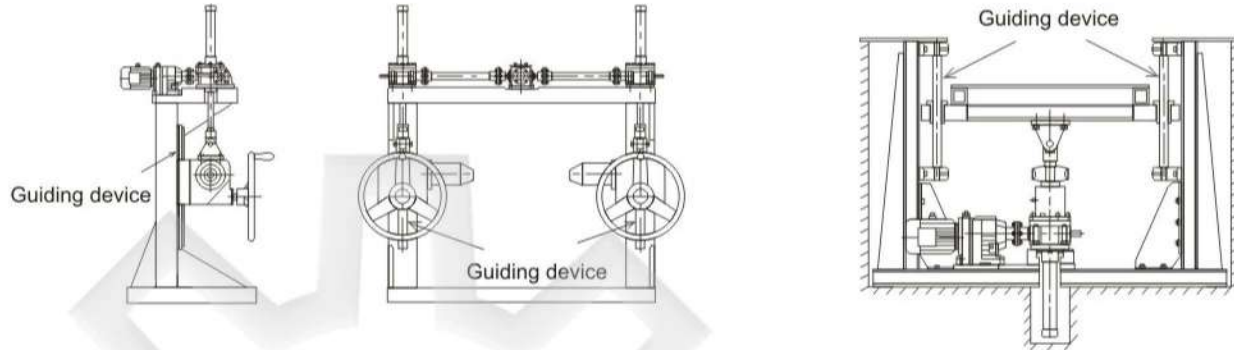

Please verify input torque of each Jack when several Jack are connected on the same input axial line as the following,

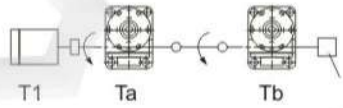

Ta: Required torque of input shaft of jack a.
Tb: Required torque of input shaft of jack b.
Required torque of motor T1=Ta+Tb<Promitted input torque of jack a.

Jack selection example:

Example: Four Jacks, linked as the following drawing, normal temperature, thin dust, radial load, with guiding devices on one side, foot-mounted, fixed the screw top-end, 380v/50Hz, service frequency: 2 times/hour, service time: 8 hours.

1. Maximum axial load; 88.2KN/4 Jacks
2. Linear speed: 10mm/s (600mm/min)
3. Service journey: 260mm

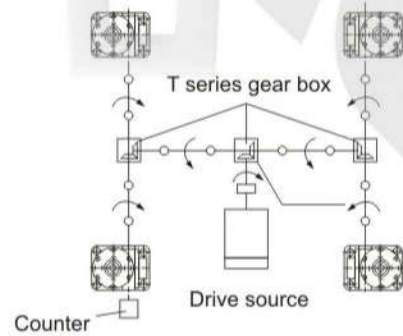

Determine Jack type,

- 1) Calculate total equivalent load Ws (Factor for driven machine is 1.3)
 $W_s = W_{max} \cdot f_1 = 88200 \times 1.3 = 114660N$
- 2) Calculate equivalent load of single jack:

$$w = \frac{114660}{4 \times 0.85} = 33724N$$

- 3) Temporarily determine type,

Temporarily determine JWB050USH according to speed, efficiency, drive and Load (refer to basic parameter table)

- 4) Verify journey:

Service journey is 260mm, determine journey should be 300 after considering surplus. (Please refer to dimension sheet of JWB050US).

- 5) Check input power:

(1) Calculate required input power:

$$\textcircled{1} n_1 = \frac{V}{L_1} \times i = \frac{0.60}{0.010} \times 6 = 360r/min$$

$$\textcircled{2} T_1 = \frac{W \times L_1}{2 \pi \times i \times \eta} + T_0 = \frac{33724 \times 0.010}{2 \times 3.14 \times 6 \times 0.64} + 1.37 = 15.4Nm$$

$$\textcircled{3} P_1 = \frac{T_1 \times n_1}{9550} = \frac{15.4 \times 360}{9550} = 0.58kW$$



Sample Part Number

(2) Refer to basic parameter table, Pmax=2.2kW>P1 ... OK

6. Verify the stability of screw

For under axial load, refer to transmission table and dimension for the following figures,

$$d=31.3 \quad L_a=604+33=637 \quad f_m=20 \times 10^4 \quad SF=4$$

$$P_{CR} = f_m \times \left(\frac{d^2}{L_a}\right)^2 = 20 \times 10^4 \times \left(\frac{31.3^2}{637}\right)^2 = 473073N$$

$$P_F = \frac{P_{CR}}{SF} = \frac{473073}{4} = 118268 > W = 33724$$

... OK

Accessory confirmation:

Support (Mode C mounting):

support-mounted mode widely apply to tilting equipment.

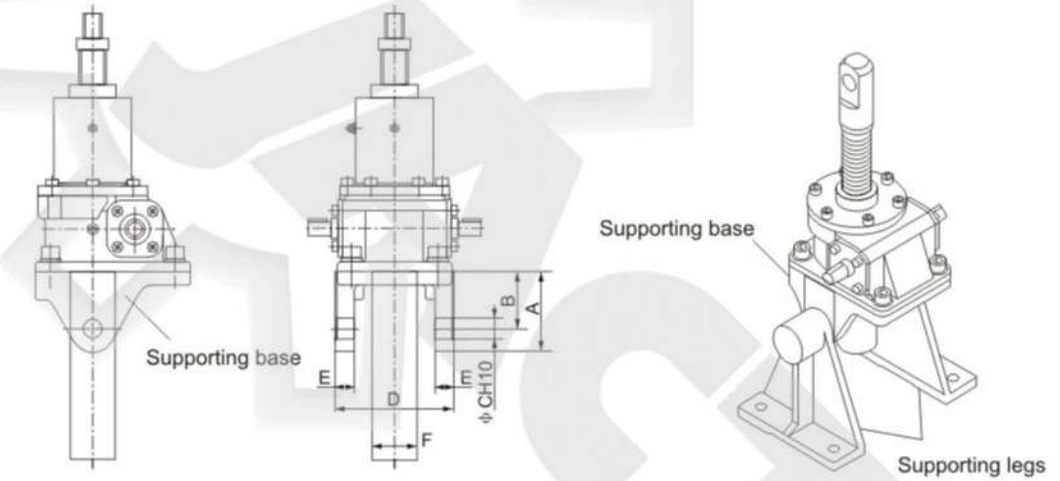

Type	A	B	C	D	E	F
010	75	60	15	86	15	35
025	100	75	20	115	20	45
050	105	75	25	158	25	58
100	145	100	40	201	30	76.3
150	155	105	50	224	44	76.3
200	173	110	63	244	50	89.1

Supporting legs:

Matching supporting base and legs realizes multi-angles lifting and lowering.



JW010-JW050

JW100-JW200



Application example

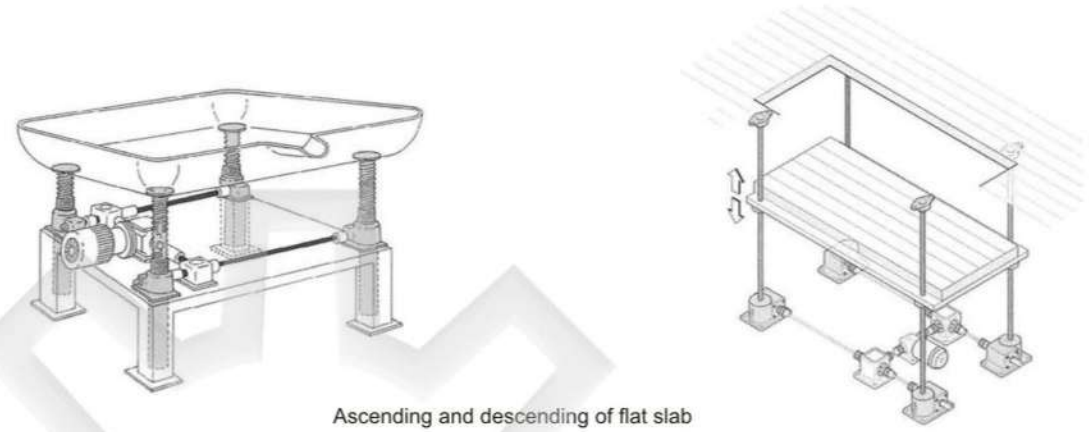

Ascending and descending of flat slab

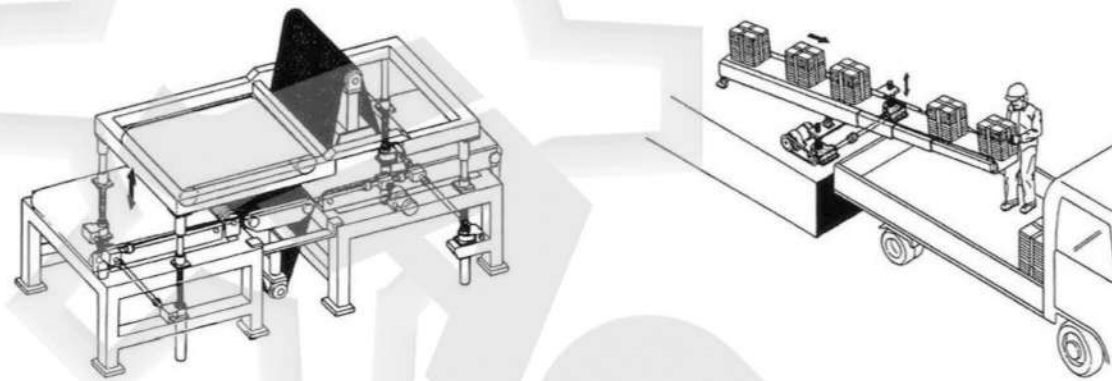

Adjust operation height of surface machining tool

Adjust inclination pitch of conveyor apron

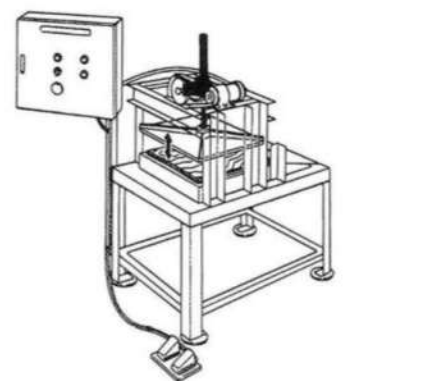

Operation height of straightening machine



Automatic switch on large windows (doors)

Dimensions

JWB010

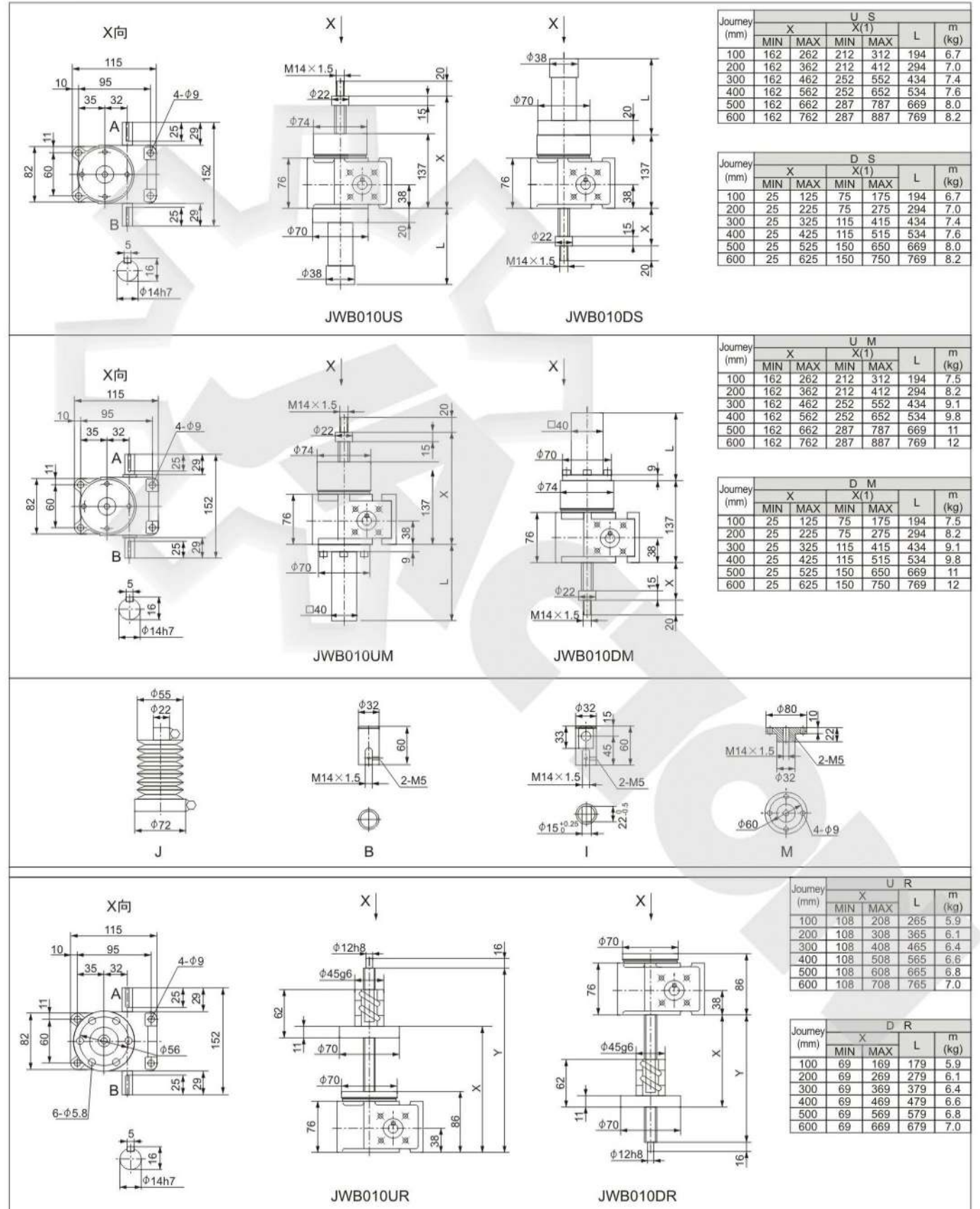

Note: "X⁽¹⁾" is the dimension of jack with dust hood.

Dimensions

JWB025

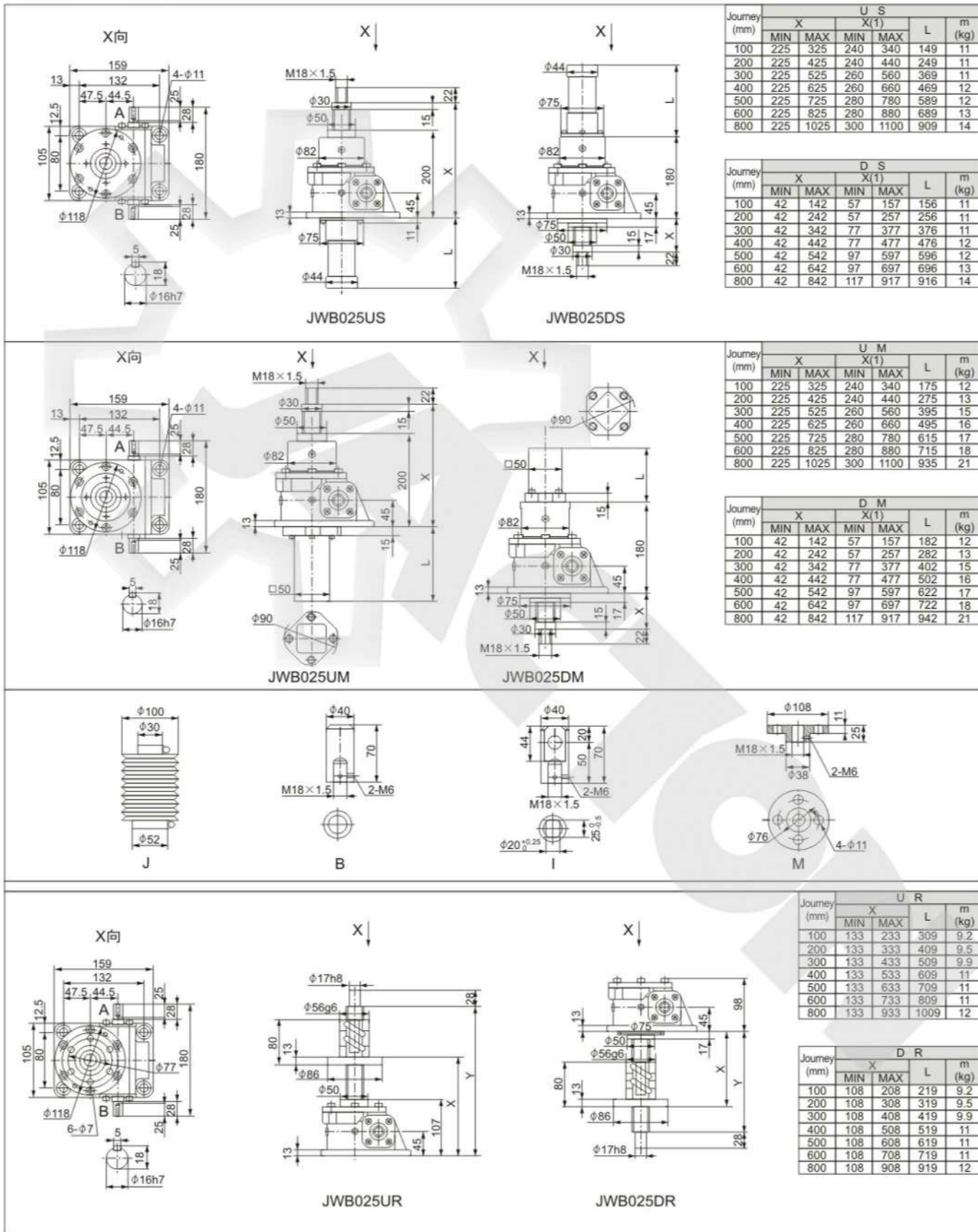

Note: "X⁽¹⁾" is the dimension of jack with dust hood.



Dimensions

JWB050

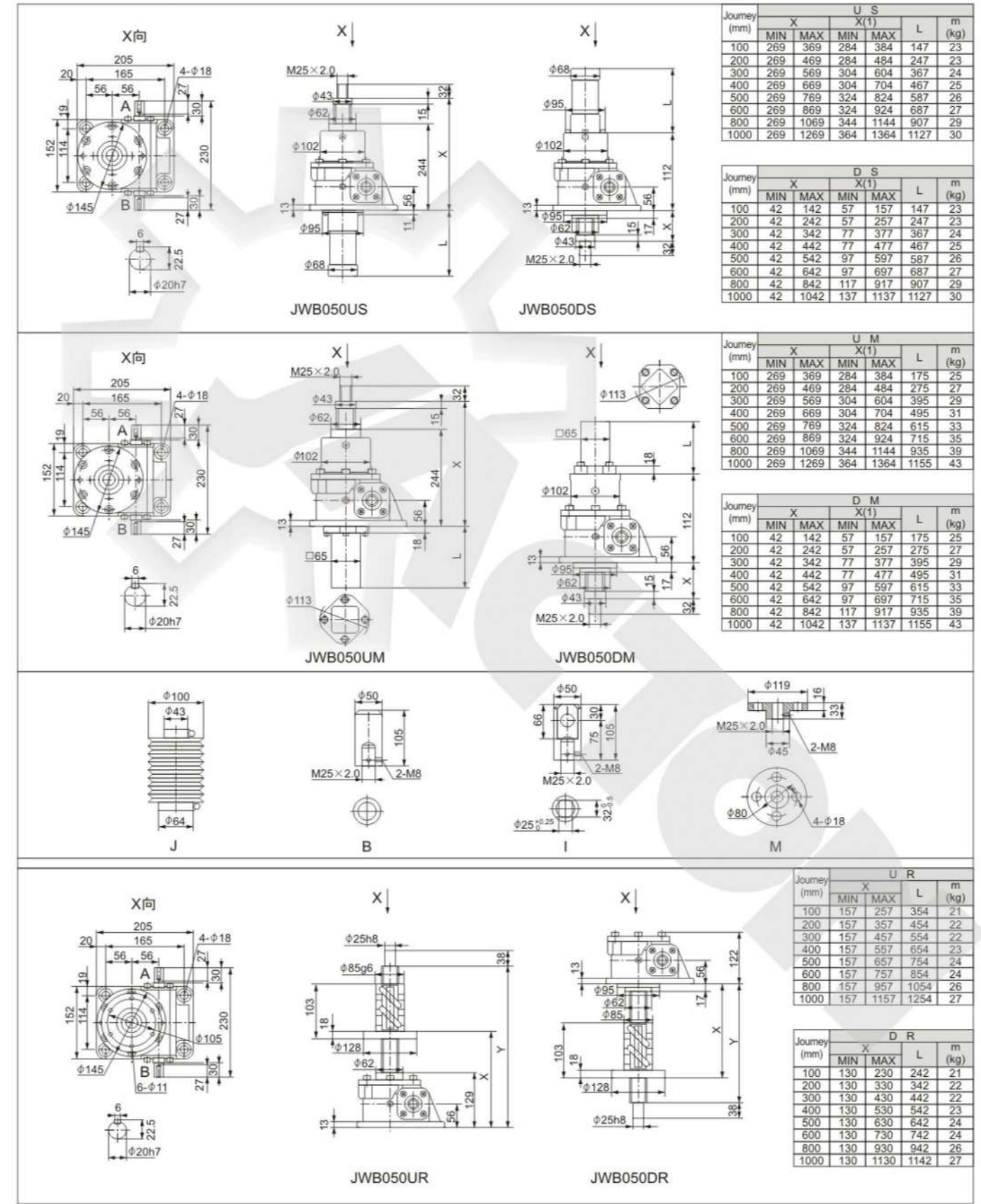

Note: "X⁽¹⁾" is the dimension of jack with dust hood.



Dimensions

JWB100

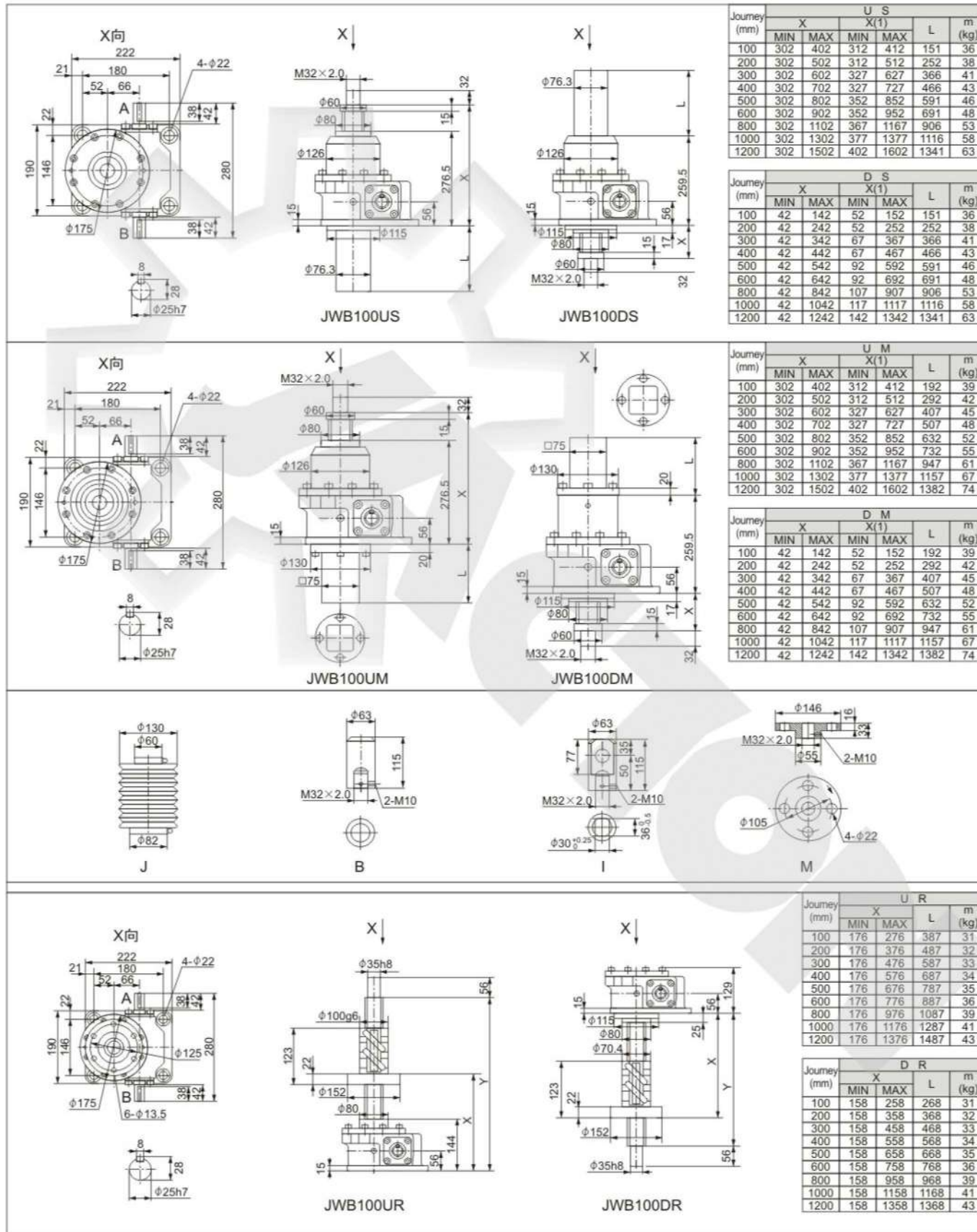

Note: "X(1)" is the dimension of jack with dust hood.



Dimensions

JWB150

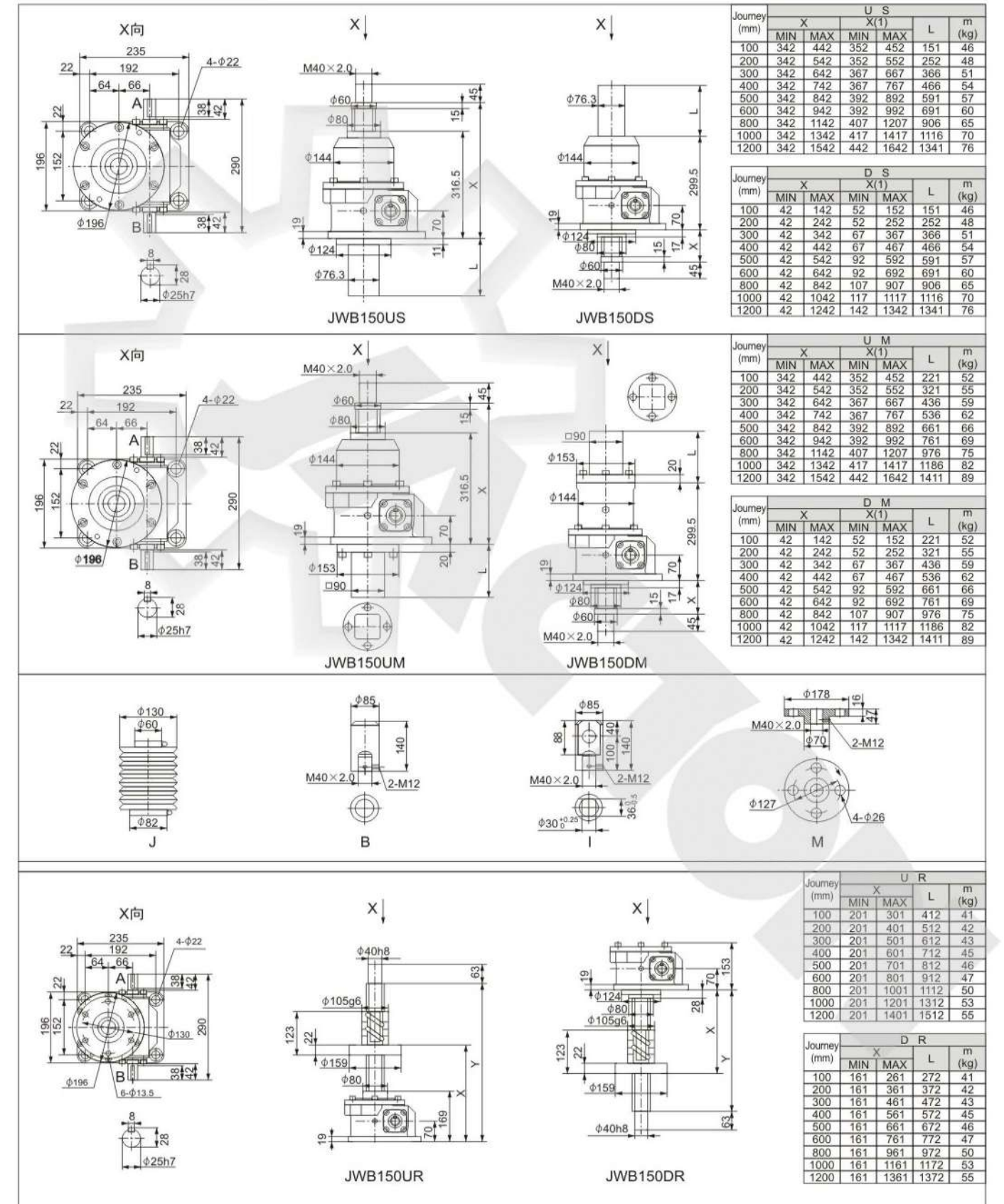

Note: "X(1)" is the dimension of jack with dust hood.



Dimensions

JWB200

Journey (mm)	X		U S		L	m (kg)
	MIN	MAX	MIN	MAX		
100	406	506	416	516	151	65
200	406	606	416	616	252	68
300	406	706	431	731	366	72
400	406	806	431	831	466	76
500	406	906	456	956	591	80
600	406	1006	456	1056	691	83
800	406	1206	471	1271	906	90
1000	406	1406	481	1481	1116	97
1200	406	1606	506	1706	1357	105

Journey (mm)	X		D S		L	m (kg)
	MIN	MAX	MIN	MAX		
100	42	142	52	152	151	65
200	42	242	52	252	252	68
300	42	342	67	367	366	72
400	42	442	67	467	466	76
500	42	542	92	592	591	80
600	42	642	92	692	691	83
800	42	842	107	907	906	90
1000	42	1042	117	1117	1116	97
1200	42	1242	142	1342	1357	105

Journey (mm)	X		U M		L	m (kg)
	MIN	MAX	MIN	MAX		
100	406	506	416	516	230	72
200	406	606	416	616	330	76
300	406	706	431	731	445	80
400	406	806	431	831	545	84
500	406	906	456	956	670	89
600	406	1006	456	1056	770	93
800	406	1206	471	1271	985	102
1000	406	1406	481	1481	1195	110
1200	406	1606	506	1706	1420	119

Journey (mm)	X		D M		L	m (kg)
	MIN	MAX	MIN	MAX		
100	42	142	52	152	230	72
200	42	242	52	252	330	76
300	42	342	67	367	445	80
400	42	442	67	467	545	84
500	42	542	92	592	670	89
600	42	642	92	692	770	93
800	42	842	107	907	985	102
1000	42	1042	117	1117	1195	110
1200	42	1242	142	1342	1420	119

Journey (mm)	X		U R		L	m (kg)
	MIN	MAX	MIN	MAX		
100	224	324	435	56		
200	224	424	535	58		
300	224	524	635	60		
400	224	624	735	62		
500	224	724	835	65		
600	224	824	935	67		
800	224	1024	1135	71		
1000	224	1224	1335	76		
1200	224	1424	1535	80		

Journey (mm)	X		D R		L	m (kg)
	MIN	MAX	MIN	MAX		
100	164	264	274	56		
200	164	364	374	58		
300	164	464	474	60		
400	164	564	574	62		
500	164	664	674	65		
600	164	764	774	67		
800	164	964	974	71		
1000	164	1164	1174	76		
1200	164	1364	1374	80		

Note: "X⁽¹⁾" is the dimension of jack with dust hood.



Dimensions

JWB300

Journey (mm)	X		U S		L	m (kg)
	MIN	MAX	MIN	MAX		
100	480	580	490	590	160	55
200	480	680	490	690	260	55
300	480	780	505	805	375	55
400	480	880	505	905	475	55
500	480	980	520	1020	590	55
600	480	1080	520	1120	690	55
800	480	1280	535	1335	905	55
1000	480	1480	555	1555	1125	55
1200	480	1680	565	1765	1335	55
1500	480	1980	590	2090	1660	55

Journey (mm)	X		D S		L	m (kg)
	MIN	MAX	MIN	MAX		
100	48	148	58	158	160	55
200	48	248	58	258	260	55
300	48	348	73	368	375	55
400	48	448	73	468	475	55
500	48	548	98	598	590	55
600	48	648	98	698	690	55
800	48	848	113	913	905	55
1000	48	1048	123	1123	1125	55
1200	48	1248	143	1343	1335	55
1500	48	1548	168	1668	1660	55

Note: "X⁽¹⁾" is the dimension of jack with dust hood.



JWB500

Journey (mm)	X		U S		L	m (kg)
	MIN	MAX	MIN	MAX		
100	580	680	585	685	165	55
200	580	780	585	785	265	55
300	580	880	605	905	385	55
400	580	980	605	1005	485	55
500	580	1080	615	1115	595	55
600	580	1180	615	1215	695	55
800	580	1380	630	1430	910	55
1000	580	1580	645	1645	1125	55
1200	580	1780	655	1855	1335	55
1500	580	2080	675	2175	1665	55

Journey (mm)	X		D S		L	m (kg)
	MIN	MAX	MIN	MAX		
100	58	158	68	168	165	55
200	58	258	68	268	265	55
300	58	358	83	383	385	55
400	58	458	83	483	485	55
500	58	558	108	618	590	55
600	58	658	108	718	690	55
800	58	858	123	923	910	55
1000	58	1058	133	1123	1125	55
1200	58	1258	153	1323	1335	55
1500	58	1558	178	1623	1665	55