

# JSS

## Stainless Steel Screw Jack

<b>Descriptions</b>	<b>001</b>
<b>Materials</b>	<b>001 - 002</b>
<b>Selection Guide</b>	<b>003 - 013</b>
Selection Notes	003
Unit Converter	004
Calculation Formulas	005
Sample Part Number	010
<b>Permissible Buckling Load</b>	<b>014</b>
<b>Specifications</b>	<b>015</b>
<b>Performance Tables</b>	<b>016 - 018</b>
JSS-1T ~ JSS-2.5T	016
JSS-5T ~ JSS-10/15T	017
JSS-20T	018
<b>Overall Dimensions</b>	<b>018 - 020</b>
JSS-1T	018
JSS-2.5T ~ JSS-5T	019
JSS-10/15T ~ JSS-20T	020
<b>Permitted Lateral Force On the Lifting Screw <math>F_s</math> (N)</b>	<b>021</b>
<b>Permitted Radial Force On Input Shaft <math>F_r</math> (N)</b>	<b>022</b>
<b>Other Products</b>	<b>023 - 026</b>
<b>Contact Us</b>	<b>027</b>

Contents

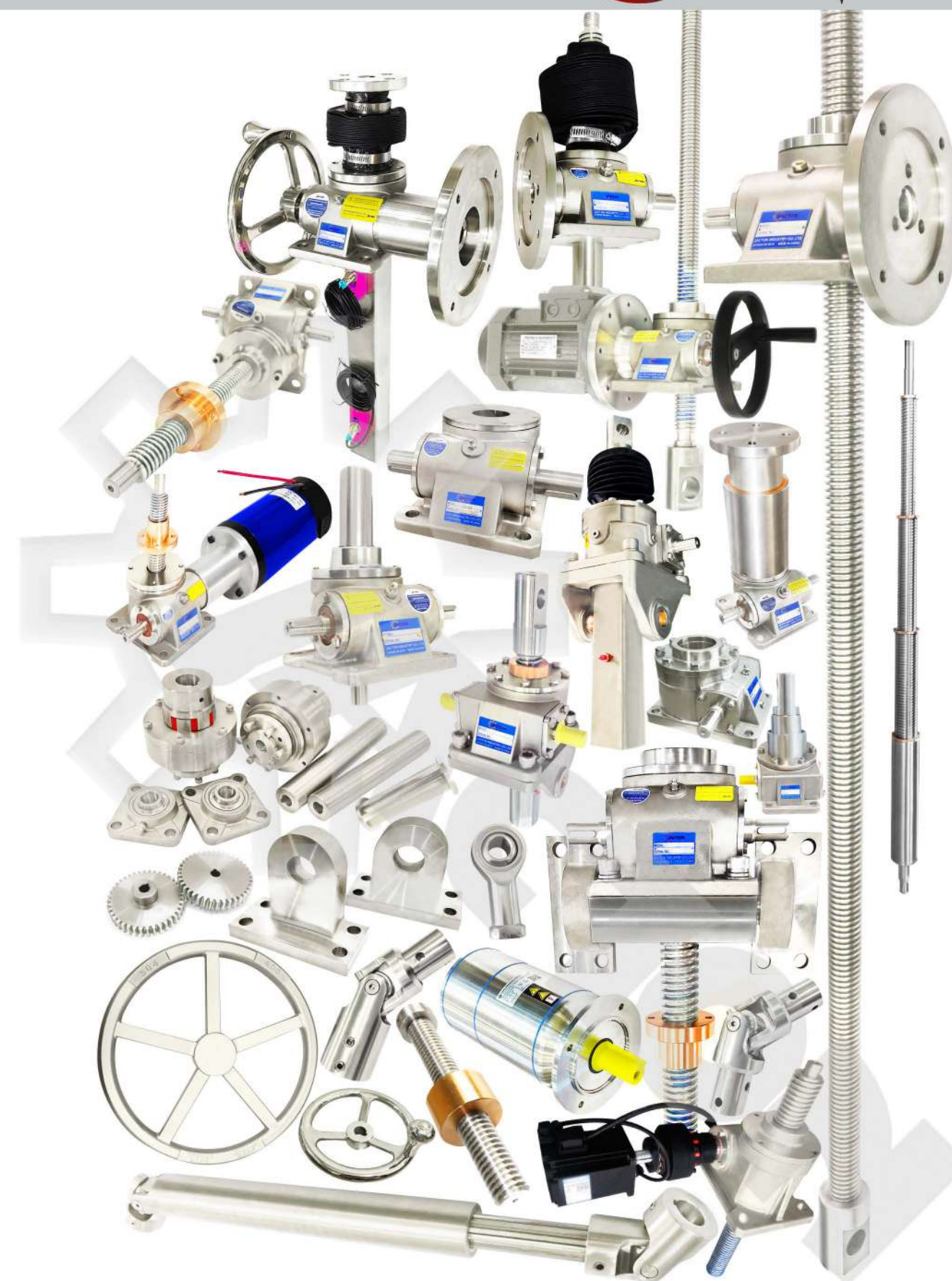



## Descriptions

**Complete JSS Series Stainless Steel Screw Jacks** use a stainless steel worm with a high strength bronze worm gear. All external components are manufactured from 304 or 316 Stainless Steel materials. They are ideal for use in wet, harsh or corrosive environments, or those with a regular wash down requirement, chemical or food industries. Due to the classic design, you don't need to attach any construction elements to the housing. In the absence of vibration load, they have self-locking and precisely position loads, will hold loads without backdriving, and no need any brake mechanism or locking system. Under normal operation, maintenance free.

### Key Features

- 6 sizes in two gear ratios (high ratio, slow ratio) for high and slow linear speeds (up to 2.25 m/min).
- Static load capacities from 1 ton to 20 tons as Standard.
- Self locking trapezoidal screw offers maximum stroke of 6 m, precise positioning, and uniform speed.
- Basic designs: Translating screw, Keyed screw, and Rotating screw.
- Upright or Inverted mounting. Available in tension or compression loads.
- Standard with 1-start thread screw, custom 2-starts threads screw which offers increased travel speed and require a brake or external locking device to hold position.
- Power source: manual operation with hand wheel, electrically by motor driven.
- Can be applied either individually use or combined into a exactly synchronized lifting system(multiple jack systems), linked by connecting shafts, bevel gearboxes, couplings, electric motors, gear reducers, limit switches and pillow blocks etc.
- Can be used as alternatives to hydraulic and pneumatic systems.

## Materials

We use the best materials to guarantee the performance and lifetime of the stainless steel screw jacks you purchased.

### Housing

- Stainless steel #304.

### Lifting Screw

- Stainless steel #304. Custom stainless steel #316

### Input Shaft (Worm)

- Stainless steel #304. Custom stainless steel #316.

### Worm Gear / Travelling Nut / Safety Nut

- High Strength Bronze ZQA19-4 (Casting aluminum bronze) as Standard, Custom High Strength Bronze ZCuSn10Pb1(Casting tin bronze)

### Bearing

- Anti-friction Ball Thrust Bearings as standard. Custom stainless steel #304.

### Motor Flange Adapter

- Stainless steel #304.

### Lifting Screw Ends (Top Plate, Clevis End)

- Stainless steel #304.

### Protective tube

- Stainless steel #304.

### Lubricants

- Synthetic Grease, Extreme Pressure EP2 Lithium Grease.

## Materials





**Selection Guide**

**Selection Notes**

- (01) Screw Jacks and Lifting Systems are for industrial use only, not recommended for transporting personnel.
- (02) Carefully consider jack ratings before making a selection. Be sure that the dynamic or static load carried or sustained by jack does not exceed its maximum capacity.
- (03) Carefully consider the combination of screw shaft speed (rpm) and rated load. Also, take extra care in verifying rated buckling load and screw shaft speed (rpm). Exceeding the data provided in this catalog can cause major damage to the system.
- (04) Make sure that the surface temperature of the housing does not exceed temperature of -15°C to +80°C during operation. If using a traveling nut jack, measure the traveling nut surface temperature. Make sure all the rotating parts are completely stopped before proceeding to measure.
- (05) The maximum input speed is 1500 rpm as long as the input power dose not exceed the jack's maximum allowable input power.
- (06) Screw jack can not be operated continuously. Duty cycle based on 30 minutes.
  - **Note:** Below duty cycles are based on ambient temperatures 20°C. For ambient temperatures higher than 20°C, the duty cycle (ED) must be reduced.
    - \* Screw Jack with Trapezoidal Screw (Machine Screw Jack) duty cycle  $\leq 20\%ED$ .
    - \* Screw Jack with Ball Screw (Ball Screw Jack) duty cycle  $\leq 30\%ED$ .
  - **Note:** For operation longer than that mentioned above or for any continuous operation, the jacks temperature must be monitored and should not exceed 80°C maximum in order to determine its duty cycle.

**Duty Cycle (%ED) = [1 Duty Cycle / (1 Duty Cycle + 1 Rest Cycle)] x 100%**
- (07) Be sure not to exceed the maximum input torque for multiple screw jack systems by verifying the rated input torque for each jack.
- (08) Be sure that starting torque is 200% or more of required running torque.
- (09) Be sure that ample driving power is available to drive the jack when using in temperatures below 0°C. Low temperatures decrease the jack's efficiency due to the increased grease viscosity inside the jack's gearbox.

**Selection Guide**

- (10) Although Screw Jack with **Single-start** Trapezoidal Screw (Machine Screw Jack) has self-locking feature, vibration and shock may affect its efficiency, in which case a brake motor or extra braking device is required. Screw Jack with **Double-start** Trapezoidal Screw (Machine Screw Jack) is considered not self-locking will require a brake or other holding device. Screw Jack with Ball Screw (Ball Screw Jack) can backdrive because of their extremely high efficiencies and require some means of holding the load, such as a brake motor.
- (11) When jacks are working, can not force to stop, may result in the jacks damage or injury personnel.
- (12) When Ball Screw Jacks are under loads, can not change the motor drive to manual operation. Because the loads will cause the input shaft to rotate very dangerously.
- (13) Mechanical stops (Stop Nuts) are not provided on the lifting screw unless requested. Therefore, it is possible to drive the screw out of the jack's housing.
- (14) Never approach or touch the rotary parts (input shaft, etc.) or the lifting screw during operation.
- (15) Bellows Boots and Protective Tubes should be used to protect and keep the lifting screw clean in dusty or abrasive environments.

**Unit Converter**

- 1 ft = 304.8 mm
- 1 in = 25.4 mm
- 1 m = 10 dm = 100 cm = 1000 mm
- 1 in-lb = 0.113 Nm
- 1 Nm = 0.737 ft-lb
- 1 ft-lb = 1.356 Nm
- 1 lb = 0.454 kg
- 1 kg = 2.205 lb = 1000 g
- 1 N = 0.1 kg
- 1 t = 1000 kg = 10 kN = 2000 lb
- 1 m/min = 1000 mm/min = 16.7 mm/sec
- 1 in/sec = 25.4 mm/sec
- 1 ft/sec = 304.8 mm/sec
- 1 hp = 0.75 kW
- °C = (°F-32) / 1.8
- °F = °C x 1.8 + 32



**Selection Guide**

**Calculation Formulas**

**(01) Calculate Total Load Ws (N)**

$$W_s = W \times sf$$

Ws = Total Load (N)

W = Maximum Load (N)

sf = Safety Factor (Table 1.)

**Table 1. Safety Factor sf**

Load Conditions	Example Purposes	Safety Factor (sf)
Smooth movement with no shock, Light load	Opening and closing a valve, Adjusting a conveyor	1.0 ~ 1.3
Light shock, Medium load	Use with various kinds of transporting equipment and lifters	1.3 ~ 1.5
Severe shock and/or vibration, Heavy load	Use with large transporting carriages, Holding the position of a press roller	1.5 ~ 3.0

• **Note:** The above table is for general reference only. Consider particular operating conditions under which you operate before selecting a safety factor.

**(02) Calculate Load Per Jack Wn (N)**

$$W_n = W_s / (N_o \times fd \times \eta_g)$$

• **Note:** For a synchronous drive, use a synchronous drive coefficient (Table 2).

• **Note:** Don't ignore spiral bevel gearbox efficiency 94%.

Wn = Load Per Jack (N)

Ws = Total Load (N)

No = Number of jacks

fd = Multiple jacks system coefficient (Table 2.)

ηg = Bevel Gearbox efficiency = 94%

**Table 2. Multiple Jacks System Coefficient fd**

No. of jacks	1	2	3	4	5 ~ 8
Coefficient	1	0.95	0.9	0.85	0.8

**(03) Jack Selection**

Follow these steps to make a preliminary jack selection.

**Points of preliminary jack selection**

- Select (temporary) worm speed ratio by adjusting the screw shaft rpm. If difficult to select, inspect by H speed.
- Consider traveling space when selecting stroke.
- Select options based on your needs.

**Selection Guide**

**(04) Verifying Allowable Buckling Load Pcr (N)**

For a compressive load, verify that it does not exceed the allowable buckling load. If it does, increase jack size and recalculate.

$$P_{CR} = f_m \times (d^2 / L)^2, \text{ Make Sure } P_{CR} > W_n \times sf \text{ (sf = 4 as usual)}$$

Pcr = Allowable buckling load (N)

f<sub>m</sub> = Support coefficient (Table 4.)

L = Distance between load-supporting plane(point) and mounting plane(point) (mm)

d = Screw shaft root diameter (mm) = D - TP - 2 x ac TP = Screw pitch (mm)

W<sub>n</sub> = Load Per Jack (N) D = Screw diameter (mm) ac = Assembly clearance (Table 3.)

**Table 3. Assembly Clearance ac**

Screw Pitch (mm)	ac
1.5 - 5	0.25
6 - 12	0.5
14 - 44	1

**Table 4. Support Coefficient fm**

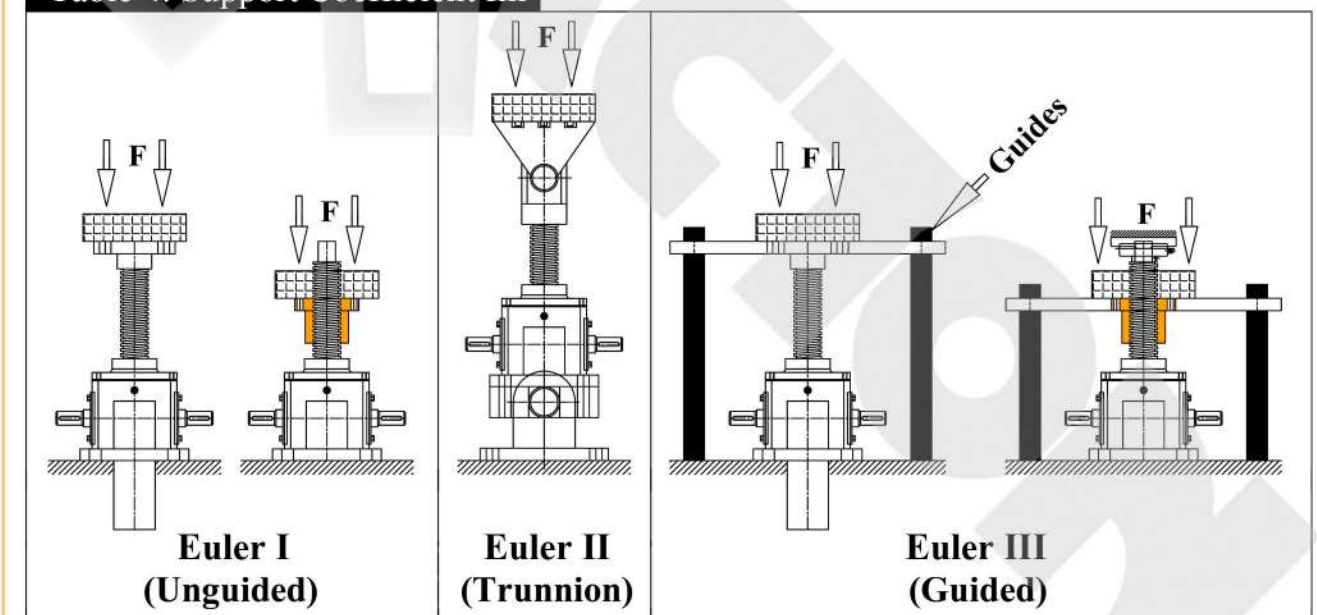

- **Euler I (fm = 2.5 x 10<sup>4</sup>):** Screw jack housing fixed to the base (foot-mounted). Lifting screw end (or travelling nut) lifting the free load (unguided).
- **Euler II (fm = 1 x 10<sup>5</sup>):** Screw jack housing and lifting screw end (or travelling nut) are trunnion mounted by pin or joint for pivot drive.
- **Euler III (fm = 2 x 10<sup>5</sup>):** Screw jack housing fixed to the base (foot-mounted). Lifting screw end (or travelling nut) lifting the fixed load (guided).



**Selection Guide**

**Calculation Formulas**

■ **(05) Verifying Allowable Screw Speed  $N_C$  (rpm)**

- **Note:** Only for Screw Jack with Traveling Nut (Rotating Screw Jack), verify that it does not exceed the allowable screw shaft rpm. If it does, increase jack size and recalculate.

$$N_C = (96 \times f_n \times d \times 10^6) / L^2, \text{ Make Sure } N_C > n_2, n_2 = n_1 / i$$

$N_C$  = Allowable screw shaft speed (rpm)       $f_n$  = Shaft end support coefficient (Table 5.)

$L$  = Distance between load-supporting plane and mounting plane (mm) (Table 5.)

$d$  = Screw shaft root diameter (mm) =  $D - TP - 2 \times ac$        $TP$  = Screw pitch (mm)

$D$  = Screw diameter (mm)       $ac$  = Assembly clearance (Table 3.)

$n_2$  = Output speed of screw shaft (rpm)       $n_1$  = Input speed of worm shaft (rpm)

$i$  = Gear ratio

**Table 5. Shaft End Support Coefficient  $f_n$**

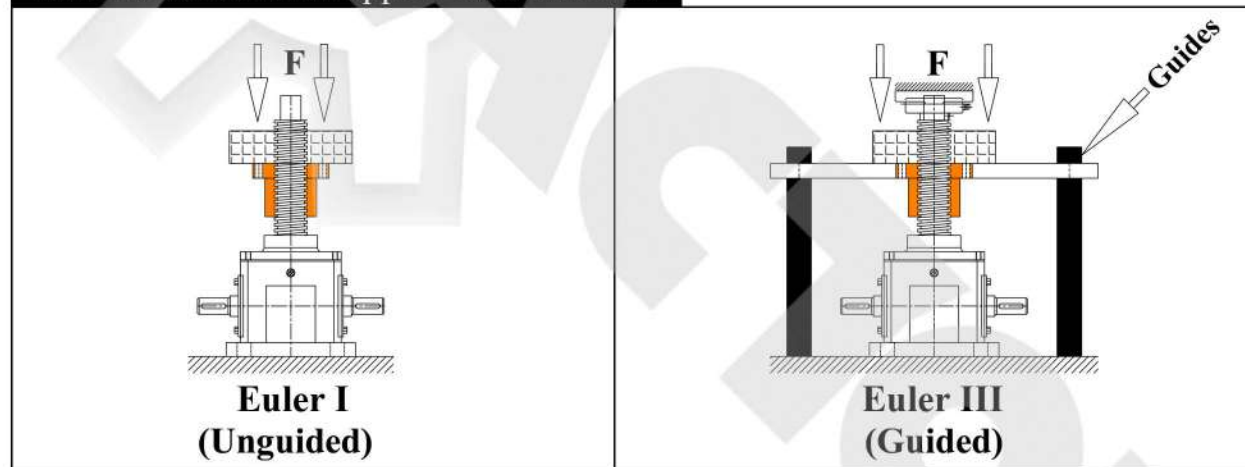

- **Euler I ( $f_n = 0.36$ ):** Screw jack housing fixed to the base (foot-mounted). Travelling nut lifting the free load (unguided).
- **Euler III ( $f_n = 1.56$ ):** Screw jack housing fixed to the base (foot-mounted). Travelling nut lifting the fixed load (guided).

■ **(06) Confirming Required Input Speed  $n_1$  (rpm)**

Determine the required input rpm, using the required screw shaft speed.

- **Note:** Input speed should not exceed 1500 rpm.

$$n_1 = v \times i / TP$$

$v$  = Lifting speed (mm/min)

$n_1$  = Input speed of worm shaft (rpm)

$TP$  = Screw pitch (mm)

$i$  = Gear ratio

**Selection Guide**

■ **(07) Verifying Required Input Torque per  $T$  (Nm)**

$$T = (F_{dyn} \times TP) / (2 \times \pi \times \eta \times i) + T_o$$

$F_{dyn}$  = Dynamic axial force (= lifting force) (kN)       $F_{stat}$  = Static axial force (= retention force) (kN)

$TP$  = Screw pitch (mm)       $\pi = 3.1416$

$\eta$  = Screw jack efficiency (see the Specifications of Jack Series)

\* For Machine Screw Jacks, normal  $\eta = 0.15$  (H ratio),  $\eta = 0.12$  (L ratio)

\* For Ball Screw Jacks, normal  $\eta = 0.3 \sim 0.35$  (H ratio),  $\eta = 0.22$  (L ratio)

$i$  = Gear ratio

$T_o$  = Idling torque (Nm) (see the Specifications of Jack Series)

■ **(08) Verifying Required Input Power  $P$  (kW)**

$$P = W_1 \times v_1 / (6000 \times \eta)$$

$P$  = Input power (kW)       $W_1$  = Lifting force (kgf)       $v_1$  = Lifting speed (m/min)

$\eta$  = Screw jack efficiency (see the Specifications of Jack Series)

\* For Machine Screw Jacks, normal  $\eta = 0.15$  (H ratio),  $\eta = 0.12$  (L ratio)

\* For Ball Screw Jacks, normal  $\eta = 0.3 \sim 0.35$  (H ratio),  $\eta = 0.22$  (L ratio)

■ **(09) Other Calculation Formulas**

09.01) Lifting Speed:  $v = n_1 \times TP / i$

09.02) Stroke / Revolution:  $SR = TP / i$

09.03) Input Torque:  $T = 9550 \times P / n_1 + T_o$

09.04) Input Power:  $P = T \times n_1 / 9550$

09.05) Starting Torque per Jack:  $T_{st} \approx T \times 1.3$

09.06) Hand Wheel Turning Force:  $W_{hw} = T / R_{hw}$

09.07) Input Power of Multiple Jacks System:  $P_s = P \times N_o / (fd \times \eta_g)$

09.08) Input Torque of Multiple Jacks System:  $T_s = T \times N_o / (fd \times \eta_g)$

09.09) Screw Shaft Pitch Diameter:  $d_2 = D - 0.5 \times TP$

09.10) Screw Shaft Torque:  $T_{hub} = F_{dyn} \times (d_2 / 2) \times \tan(\alpha \pm \phi)$ ,  $\phi \approx 6^\circ$

09.11) Lead Angle:  $\alpha = \arctan[TP / (d_2 \times \pi)]$

- **Note:** A prerequisite is a vibration-free operation

\* Self-locking at standstill (Static):  $2.4^\circ < \alpha < 4.5^\circ$ , may require brake motor

\* Self-locking from movement (Dynamic):  $\alpha < 2.4^\circ$ , don't require brake motor

\* No self-locking:  $\alpha > 4.5^\circ$ , require brake motor



**Selection Guide**

**Calculation Formulas**

09.12) Duty cycle based on 1 hour:  $ED = [S \times As \times 5 / (3 \times v)] \times 100\%$

09.13) Ball Screw Service Life in Hours:  $L_h = (C_{dyn} / F_{dyn})^3 \times 10^6 / (n_2 \times 60)$ ,  $n_2 = n_1 / i$

- **Note:** Trapezoidal Screw Service Life cannot be determined by the formula used to calculate a Ball Screw wear life. Use the information below as a reference.  
50kN(5 ton) and below models average expected life 5000 meters.  
100kN(10 ton) and above average expected life 1000 meters.

v = Lifting speed (mm/min)

n1 = Input speed of worm shaft (rpm)

n2 = Output speed of screw shaft (rpm)

TP = Screw pitch (mm)

i = Gear ratio

SR = Stroke / Revolution (mm)

N<sub>o</sub> = Number of jacks

fd = Multiple jacks system coefficient (Table 2.)

η<sub>g</sub> = Bevel Gearbox efficiency, η<sub>g</sub> ≈ 94%

P = Input power per jack (kW)

P<sub>s</sub> = Input power of multiple jacks system (kW)

T<sub>o</sub> = Idling torque (Nm)

T = Input torque per jack (Nm)

T<sub>s</sub> = Input torque of multiple jacks system (Nm)

T<sub>st</sub> = Starting torque per jack (Nm)

T<sub>hub</sub> = Screw Shaft Torque (Nm)

L<sub>h</sub> = Ball screw service life in hours (h)

C<sub>dyn</sub> = Dynamic load capacity of ball screw (kN)

F<sub>dyn</sub> = Dynamic axial force (= lifting force) (kN)

α = Lead Angle (°)

φ = Dynamic friction angle (°)

d<sub>2</sub> = Pitch diameter (mm)

D = Screw shaft diameter (mm)

W<sub>hw</sub> = Hand wheel turning force (N)

R<sub>hw</sub> = Hand wheel radius (m)

π = 3.1416

ED = Duty Cycle (%/hr)

S = Length of Stroke (mm)

As = Number of load cycles (up and down movement).

\* **Example:** 5 times in and out movement of the screw shaft equals 10 double strokes.

**Selection Guide**

**Sample Part Number ( Example ) :**

JSS-5T - US - 300 - H - I - C - PP  
(1) (2) (3) (4) (5) (6) (7)

**(1) Models & (4) Gear Ratios**

JSS-1T (Tr24x4) H=1:6 L=1:24	JSS-2.5T (Tr30x6) H=1:6 L=1:24	JSS-5T (Tr40x7) H=1:6 L=1:24
JSS-10T/15T (Tr58x12) H=1:8 L=1:24	JSS-20T (Tr65x12) H=1:8 L=1:24	H: High ratio L: Slow ratio

- 1.1) **Model Note 1:** the model indicates the maximum static load of this screw jack, but not the Maximum dynamic load. The dynamic load depends on the lifting speed, travel length and others working conditions.
- 1.2) **Model Note 2:** The slower the lifting speed, the greater the dynamic load.
- 1.3) **Model Note 3:** In the case of compressed loads and long strokes, please calculate maximum critical buckling force.
- 1.4) **Gear Ratio Note 1:** Screw jacks with gear ratios between 24:1, are self-locking and, in the absence of vibration, will hold loads without backdriving. All other ratios may require a brake to prevent backdriving.
- 1.5) **Gear Ratio Note 2:** Every screw jack model with 2 gear ratios as a standard. Custom others gear ratios.

**(2) Basic Designs and Configurations**

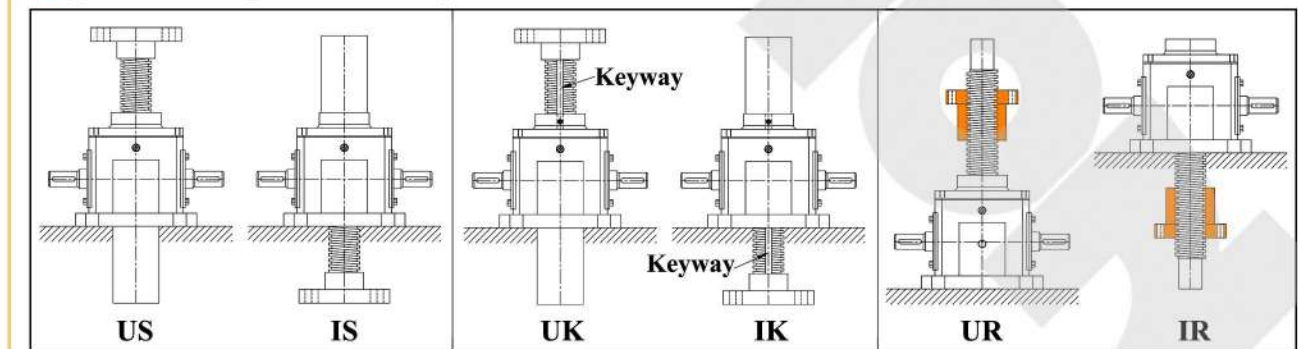

2.1) "US" and "IS" are Translating Screw Jacks, they are the most commonly specified jack. All that is required for proper function is to restrain the rotation of the lifting screw and apply torque to the input shaft. This is often achieved through the use of guides (guided load) or by attaching a common load across multiple jacks. Most applications use this jack design.



Selection Guide

Sample Part Number

2.2) "UK" and "IK" are Keyed Screw Jacks, they are keyed for non-rotation. It is ideal for use in applications where a single jack must extend to meet and move a load to which it is not attached (unguided). Keyed jacks are commonly used in single jack applications where it would not otherwise be possible to restrain the rotation of the jack screw.

- Note: Input torque required will increase by approximately 8%.
- Note: Custom square protective tube for Anti-rotation Screw Jacks, a square nut is attached to the end of the lifting screw which is then fitted inside the tube, to prevent rotation.

2.3) "UR" and "IR" are Rotating Screw Jacks, they are also called travelling nut screw jack.

It is important to restrain the rotation of the traveling nut by applying a significant load, or more commonly by guiding the load or attaching the load across multiple jacks. The Rotating Jacks mount flush and they are ideal for applications where the physical space does not allow the lifting screw to extend below or above the housing.

2.4) Custom double clevis screw jacks, trunnion mount screw jacks and anti-backlash nut screw jacks.

(3) Stroke and (5) Screw End Fittings

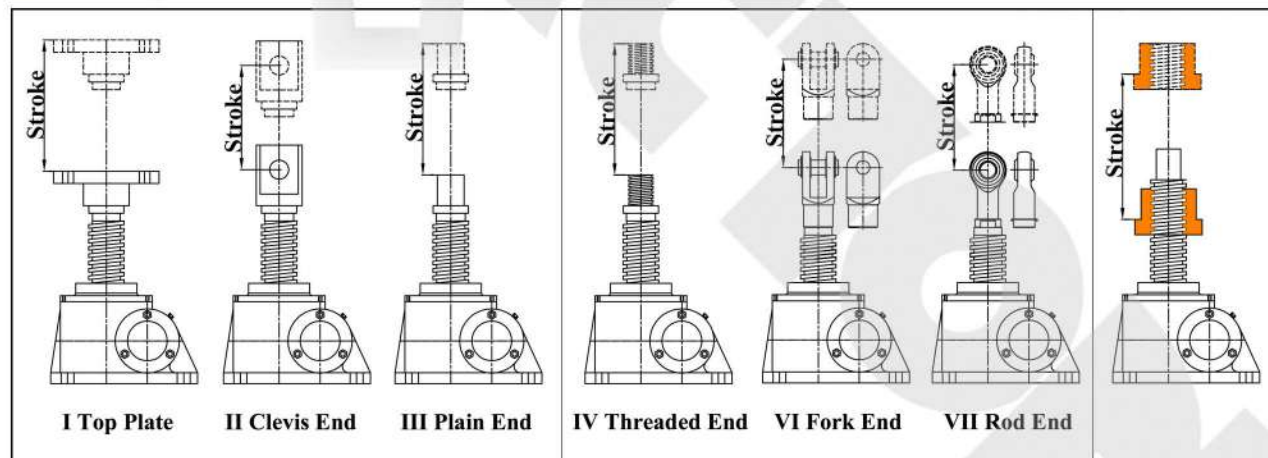

- Stroke is travel expressed in millimeter(mm) or inches and not the actual screw length.
- Standard Lifting Screw End Fittings: Top Plate (I), Clevis End (II), Plain End (III), Threaded End (IV), Forked End (VI) and Rod End (VII). Custom End Fittings are acceptable.

Selection Guide

(6) Input Shafts Codes and Motor Flange Adapters Codes (Top View)

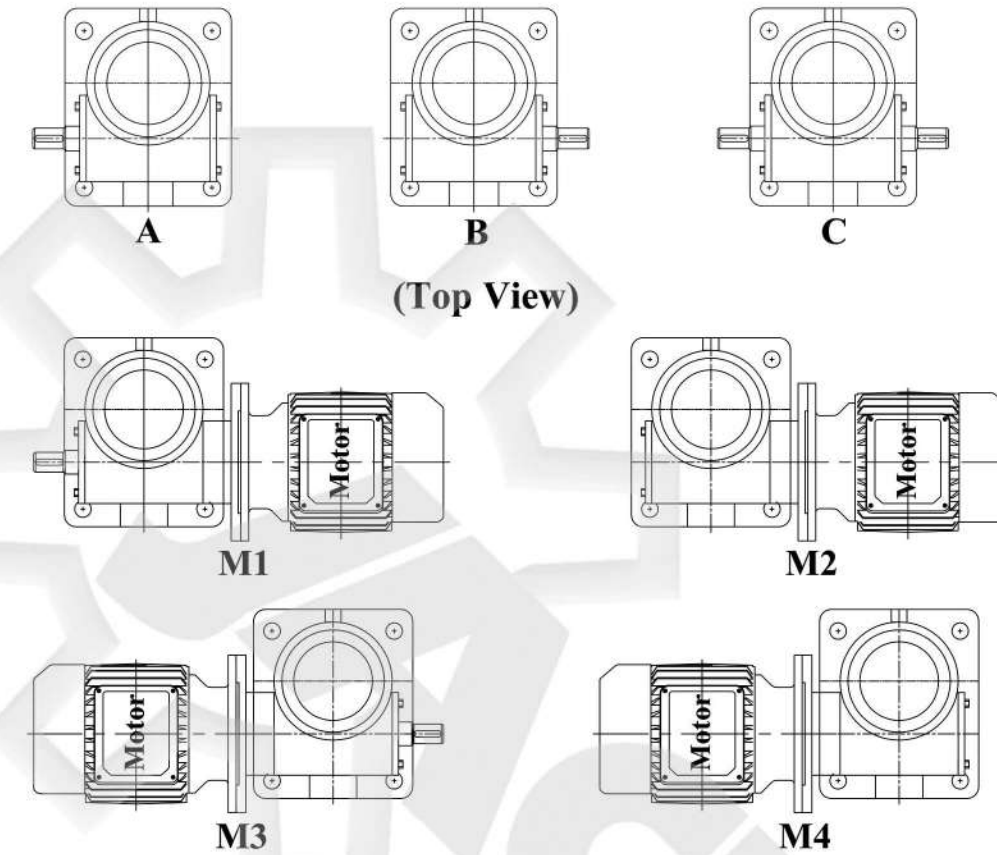

- 6.1) A: Single Input, Left Side Shaft.
- 6.2) B: Single Input, Right Side Shaft.
- 6.3) C: Double Input Shafts
- 6.4) M1: Left Side Shaft, Right Side Motor Flange Adapter (Motor Mounts).
- 6.5) M2: Right Side Motor Flange Adapter (Motor Mounts).
- 6.6) M3: Right Side Shaft, Left Side Motor Flange Adapter (Motor Mounts).
- 6.7) M4: Left Side Motor Flange Adapter (Motor Mounts).

- Note: Screw Jacks with IEC Motor Flange Adapter as a standard. Custom NEMA Motor Flange Adapter(Stepper Motor), Servo Motor Flange Adapter and Other Non-standard Motor Flange Adapters.



**Selection Guide**

**Sample Part Number**

**(7) Accessories**



**Permissible Buckling Load**

If the lifting screw is loaded in tension, the buckling can be avoided, and hence be highly economical. In case of compression load, even occasional, it is necessary to check the buckling structure. Because the thin lifting screws may buckle sideways when subjected to compressive loads.

The permissible buckling load for trapezoidal-screw and ball-screw can be verified using the following bend diagrams. Verify that it does not exceed the permissible buckling load. If it does, increase jack size and recalculate.

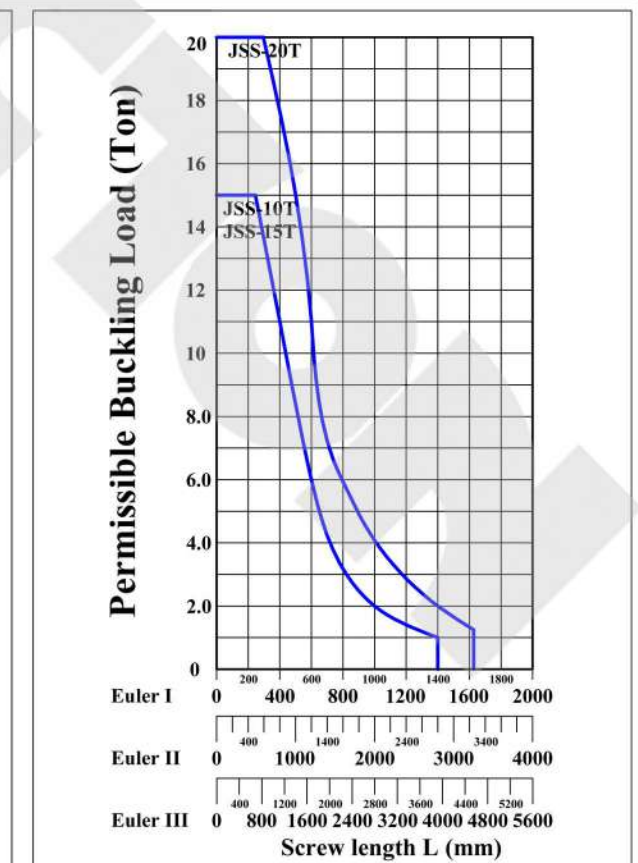
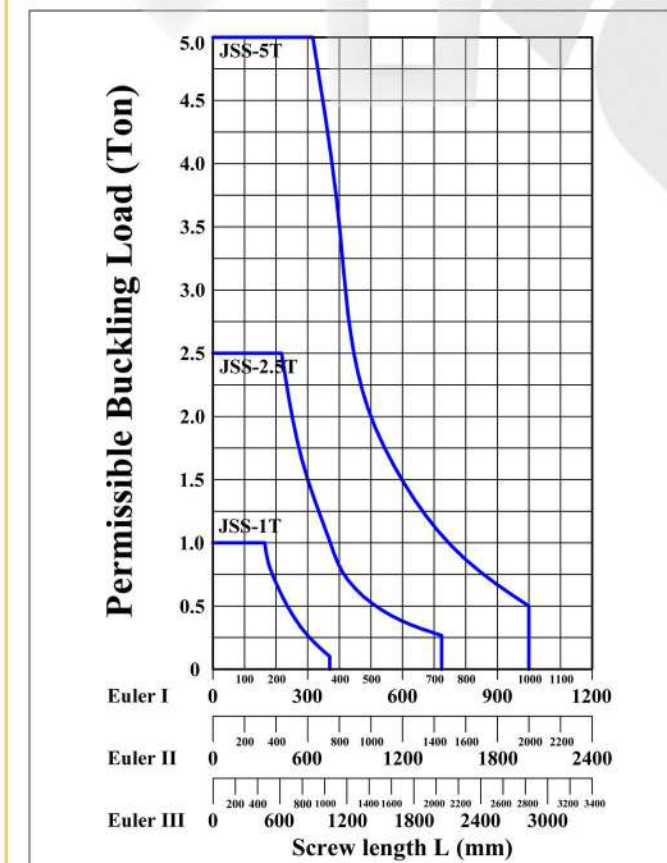
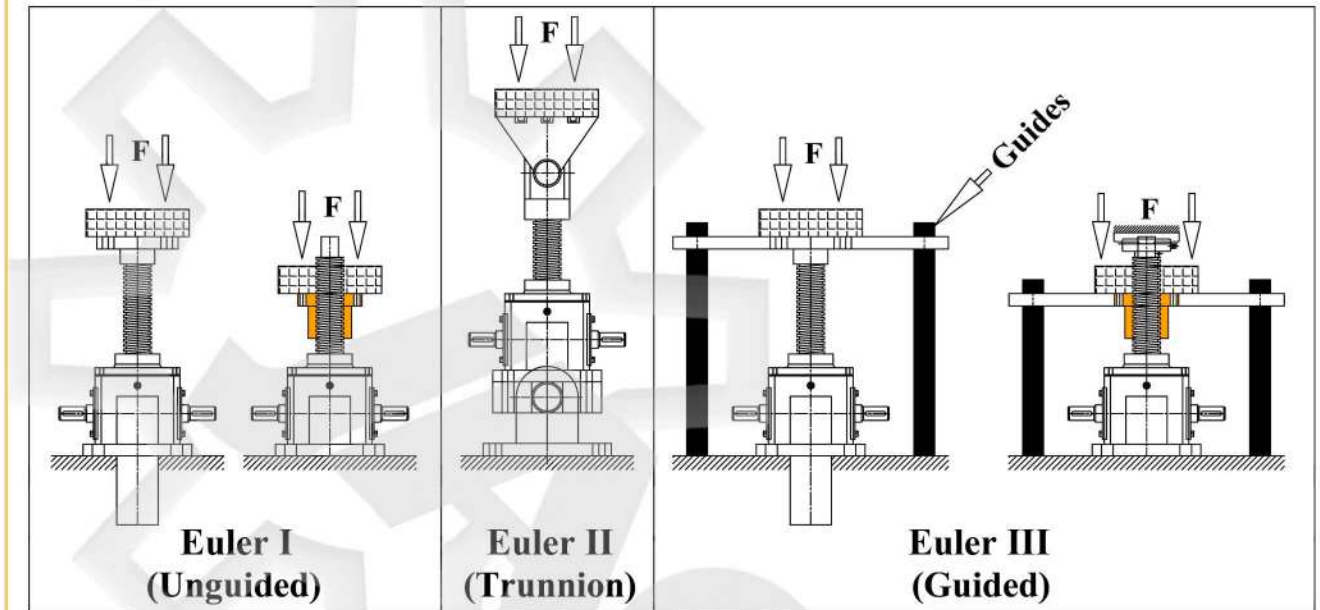



**Specifications**

• **Remarks:**

- 1) H: high ratio, L: slow ratio
- 2) Max. allowable power is under the conditions that ambient temperature 20 degree C, duty cycle 20%/h and input speed 1500rpm
- 3) Overall efficiency is under grease lubrication.
- 4) Self-locking under static conditions.

Model	JSS-1T	JSS-2.5T	JSS-5T	JSS-10T	JSS-20T
Max. lifting force (ton)	1	2.5	5	10	20
Max. pulling force (ton)	1	2.5	5	9.9	16.6
Lift screw sizes (mm)	Tr24 x 4	Tr30 x 6	Tr40 x 7	Tr58 x 12	Tr65 x 12
Gear ratio (H)	6:1	6:1	6:1	8:1	8:1
Lift screw travel (mm), per turn of input shaft (H)	0.667	1	1.167	1.5	1.5
Efficiency % (H)	21	23	21	23	21
Gear ratio (L)	24:1	24:1	24:1	24:1	24:1
Lift screw travel (mm), per turn of input shaft (L)	0.167	0.25	0.292	0.5	0.5
Efficiency % (L)	13	14	12	15	13
Max. length of lift screw (mm), when max. tensile force	1200	1500	2000	2500	3000
Max. allowable power (kw)	0.25	0.55	1.1	2.6	3.7
Lubricant (kg)	0.05	0.1	0.25	0.5	0.75
Weight without stroke (kg)	4	7.3	16.2	25	36
Weight of screw (kg), per 100 mm stroke	0.3	0.45	0.82	1.67	2.15

**Performance Tables**

- **Note:** The dark gray figures in the tables indicates operational restrictions due to thermal limits. Static only (dynamic not permitted). Selection of screw jacks using these figures should only be carried out in consultation with our engineers. When your selection is made within the areas dark gray, you will need to reduce duty cycle or choose larger model screw jacks in order to allow effective heat dissipation.

• **Conditions:** Duty cycle 20%/h or 30%/10min, 20 °C ambient temperature.

• **Gear Ratios:** H: high ratio, L: slow ratio.

• **Nm:** Input torque required, **kW:** Input power required.

**JSS-1T ( Tr24 x 4 )**

Input Speed (RPM)	Lifting Speed (MM/MIN)		F=1 Ton		F=0.8 Ton		F=0.6 Ton		F=0.4 Ton		F=0.3 Ton		F=0.2 Ton		F=0.1 Ton	
			H	L	H	L	H	L	H	L	H	L	H	L	H	L
			6.6Nm	2.7Nm	5.3Nm	2.1Nm	4.0Nm	1.6Nm	2.7Nm	1.0Nm	2.0Nm	0.8Nm	1.3Nm	0.53Nm	0.66Nm	0.27Nm
	H	L	kW	kW	kW	kW	kW	kW	kW	kW	kW	kW	kW	kW	kW	kW
1500	1000.0	250.0	1.00	0.40	0.80	0.32	0.60	0.24	0.40	0.16	0.30	0.12	0.20	0.08	0.10	0.04
1000	666.7	166.7	0.67	0.27	0.53	0.21	0.40	0.16	0.27	0.11	0.20	0.08	0.13	0.05	0.07	0.03
750	500.0	125.0	0.50	0.20	0.40	0.16	0.30	0.12	0.20	0.08	0.15	0.06	0.10	0.04	0.05	0.02
500	333.3	83.3	0.33	0.13	0.27	0.11	0.20	0.08	0.13	0.05	0.10	0.04	0.07	0.03	0.03	0.01
300	200.0	50.0	0.20	0.08	0.16	0.06	0.12	0.05	0.08	0.03	0.06	0.02	0.04	0.02	0.02	0.01
200	133.3	33.3	0.13	0.05	0.11	0.04	0.08	0.03	0.05	0.02	0.04	0.02	0.03	0.01	0.01	0.01
100	66.7	16.7	0.07	0.03	0.05	0.02	0.04	0.02	0.03	0.01	0.02	0.01	0.01	0.01	0.01	0.00
50	33.3	8.3	0.03	0.01	0.03	0.01	0.02	0.01	0.01	0.01	0.01	0.00	0.01	0.00	0.00	0.00

**JSS-2.5T ( Tr30 x 6 )**

Input Speed (RPM)	Lifting Speed (MM/MIN)		F=2.5 Ton		F=2.0 Ton		F=1.5 Ton		F=1.0 Ton		F=0.5 Ton		F=0.25 Ton		F=0.1 Ton	
			H	L	H	L	H	L	H	L	H	L	H	L	H	L
			18Nm	7.1Nm	14Nm	5.7Nm	11Nm	4.3Nm	6.9Nm	2.9Nm	3.5Nm	1.4Nm	1.7Nm	0.71Nm	0.7Nm	0.28Nm
	H	L	kW	kW	kW	kW	kW	kW	kW	kW	kW	kW	kW	kW	kW	kW
1500	1500	375	2.70	1.20	2.20	0.89	1.70	0.67	1.10	0.45	0.54	0.22	0.27	0.11	0.11	0.05
1000	1000	250	1.80	0.74	1.50	0.60	1.10	0.45	0.72	0.30	0.36	0.15	0.18	0.07	0.07	0.05
750	750	187.5	1.40	0.56	1.10	0.45	0.82	0.33	0.54	0.22	0.27	0.11	0.14	0.06	0.05	0.05
500	500	125	0.91	0.37	0.72	0.30	0.54	0.22	0.36	0.15	0.18	0.07	0.09	0.05	0.05	0.05
300	300	75	0.54	0.22	0.43	0.18	0.33	0.13	0.22	0.09	0.11	0.05	0.05	0.05	0.05	0.05
200	200	50	0.36	0.15	0.29	0.12	0.22	0.09	0.14	0.06	0.07	0.05	0.05	0.05	0.05	0.05
100	100	25	0.18	0.07	0.14	0.06	0.11	0.05	0.07	0.05	0.05	0.05	0.05	0.05	0.05	0.05
50	50	12.5	0.09	0.05	0.07	0.05	0.05	0.05	0.05	0.05	0.05	0.05	0.05	0.05	0.05	0.05



**Performance Tables**

**JSS-5T ( Tr40 x 7 )**

Input Speed (RPM)	Lifting Speed (MM/MIN)		F=5 Ton		F=4 Ton		F=3 Ton		F=2 Ton		F=1 Ton		F=0.5 Ton		F=0.25 Ton	
			H	L	H	L	H	L	H	L	H	L	H	L	H	L
	H	L	kW	kW	kW	kW	kW	kW	kW	kW	kW	kW	kW	kW	kW	kW
1500	1750.0	437.5	6.90	3.00	5.60	2.40	4.20	1.80	2.80	1.20	1.40	0.60	0.70	0.30	0.30	0.20
1000	1166.7	291.7	4.60	2.00	3.70	1.60	2.80	1.20	1.90	0.80	0.90	0.40	0.50	0.20	0.20	0.10
750	875.0	218.8	3.50	1.50	2.80	1.20	2.10	0.90	1.40	0.60	0.70	0.30	0.30	0.20	0.20	0.10
500	583.3	145.8	2.30	1.00	1.90	0.80	1.40	0.60	0.90	0.40	0.50	0.20	0.20	0.10	0.10	0.10
300	350.0	87.5	1.40	0.60	1.10	0.50	0.80	0.40	0.60	0.20	0.30	0.10	0.10	0.10	0.10	0.10
200	233.3	58.3	0.90	0.40	0.70	0.30	0.60	0.20	0.40	0.20	0.20	0.10	0.10	0.10	0.10	0.10
100	116.7	29.2	0.50	0.20	0.40	0.20	0.30	0.10	0.20	0.10	0.10	0.10	0.10	0.10	0.10	0.10
50	58.3	14.6	0.20	0.10	0.20	0.10	0.10	0.10	0.10	0.10	0.10	0.10	0.10	0.10	0.10	0.10

**JSS-10T/15T ( Tr58 x 12 )**

Input Speed (RPM)	Lifting Speed (MM/MIN)		F=10 Ton		F=8 Ton		F=6 Ton		F=4 Ton		F=2 Ton		F=1 Ton		F=0.5 Ton	
			H	L	H	L	H	L	H	L	H	L	H	L	H	L
	H	L	kW	kW	kW	kW	kW	kW	kW	kW	kW	kW	kW	kW	kW	kW
1500	2250	750	17.00	8.30	14.00	6.70	11.00	5.00	6.80	3.30	3.40	1.70	1.70	0.80	0.90	0.40
1000	1500	500	12.00	5.60	9.10	4.40	6.80	3.30	4.50	2.20	2.30	1.10	1.10	0.60	0.60	0.30
750	1125	375	8.50	4.20	6.80	3.30	5.10	2.50	3.40	1.70	1.70	0.80	0.90	0.40	0.40	0.20
500	750	250	5.70	2.80	4.50	2.20	3.40	1.70	2.30	1.10	1.10	0.60	0.60	0.30	0.30	0.10
300	450	150	3.40	1.70	2.70	1.30	2.00	1.00	1.40	0.70	0.70	0.30	0.30	0.20	0.20	0.10
200	300	100	2.30	1.10	1.80	0.90	1.40	0.70	0.90	0.40	0.50	0.20	0.20	0.10	0.10	0.10
100	150	50	1.10	0.60	0.90	0.40	0.70	0.30	0.50	0.20	0.20	0.10	0.10	0.10	0.10	0.10
50	75	25	0.60	0.30	0.50	0.20	0.30	0.20	0.20	0.10	0.10	0.10	0.10	0.10	0.10	0.10

**Performance Tables**

**JSS-20T ( Tr65 x 12 )**

Input Speed (RPM)	Lifting Speed (MM/MIN)		F=20 Ton		F=16 Ton		F=12 Ton		F=10 Ton		F=7.5 Ton		F=5 Ton		F=2.5 Ton	
			H	L	H	L	H	L	H	L	H	L	H	L	H	L
	H	L	kW	kW	kW	kW	kW	kW	kW	kW	kW	kW	kW	kW	kW	kW
1500	2250	750	36.00	20.00	29.00	16.00	22.00	12.00	18.00	9.60	14.00	7.20	8.90	4.80	4.50	2.40
1000	1500	500	24.00	13.00	19.00	11.00	15.00	7.70	12.00	6.40	8.90	4.80	6.00	3.20	3.00	1.60
750	1125	375	18.00	9.60	15.00	7.70	11.00	5.80	8.90	4.80	6.70	3.60	4.50	2.40	2.20	1.20
500	750	250	12.00	6.40	9.50	5.10	7.10	3.80	6.00	3.20	4.50	2.40	3.00	1.60	1.50	0.80
300	450	150	7.10	3.80	5.70	3.10	4.30	2.30	3.60	1.90	2.70	1.40	1.80	1.00	0.90	0.50
200	300	100	4.80	2.60	3.80	2.10	2.90	1.50	2.40	1.30	1.80	1.00	1.20	0.60	0.60	0.30
100	150	50	2.40	1.30	1.90	1.00	1.40	0.80	1.20	0.60	0.90	0.50	0.60	0.30	0.30	0.20
50	75	25	1.20	0.60	1.00	0.50	0.70	0.40	0.60	0.30	0.40	0.20	0.30	0.20	0.10	0.10

**Overall Dimensions**

**JSS-1T**

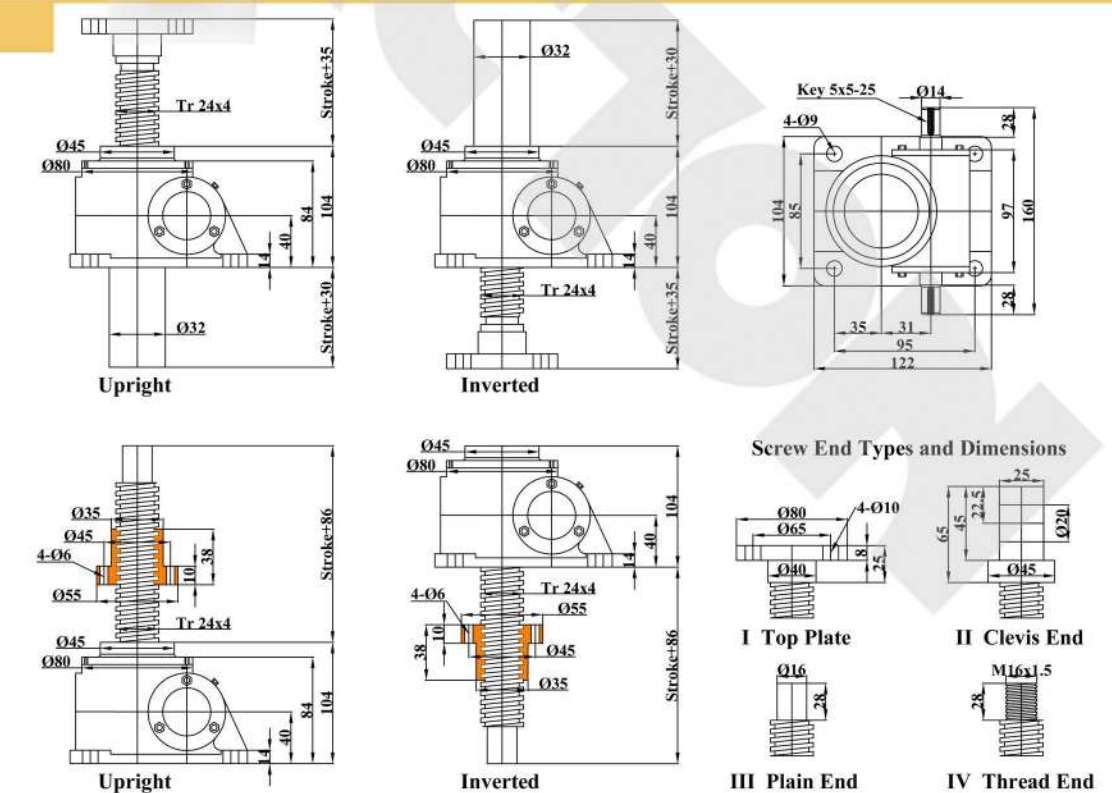

\*. Dimensions are subject to change without notice



Overall Dimensions

JSS-2.5T

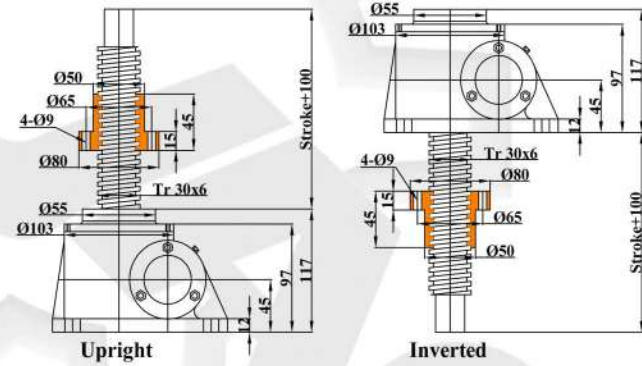
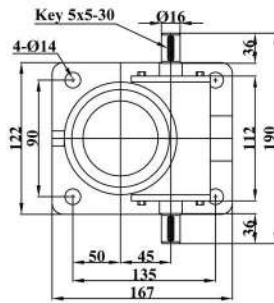
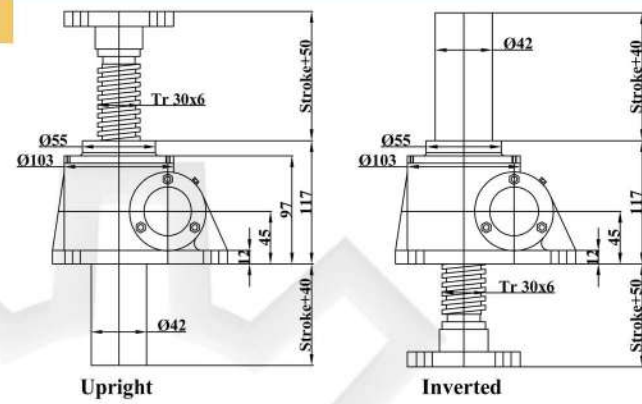

Screw End Types and Dimensions

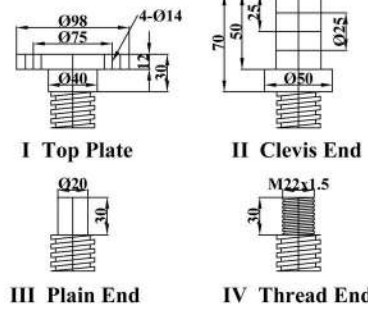

JSS-5T

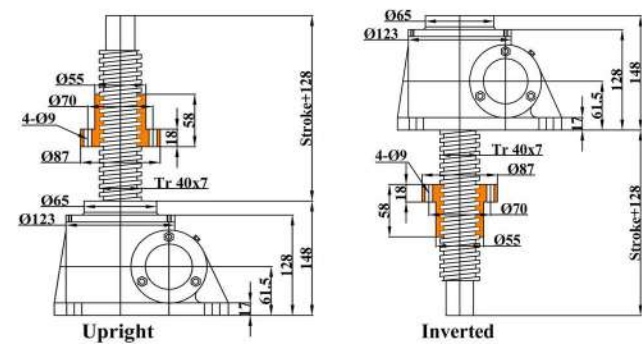
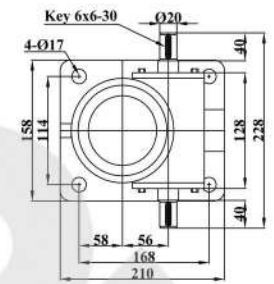
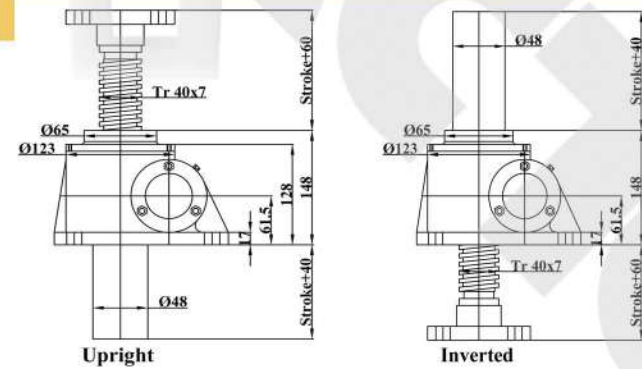

Screw End Types and Dimensions

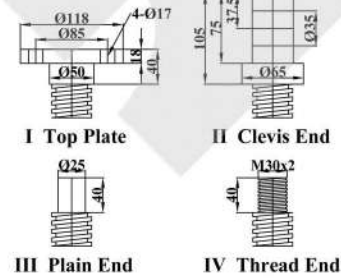

\*. Dimensions are subject to change without notice

Overall Dimensions

JSS-10T  
JSS-15T

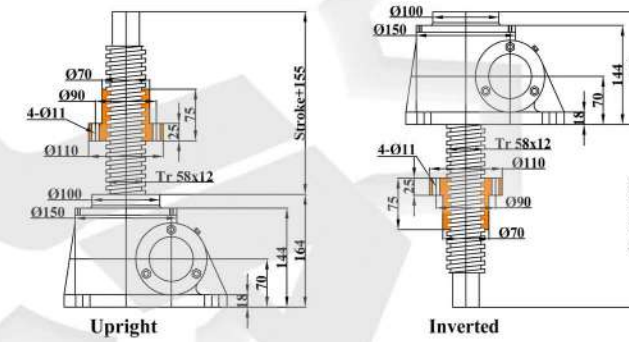
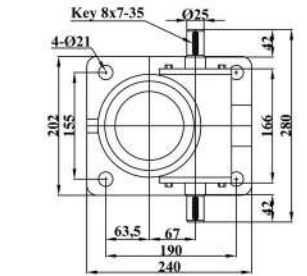
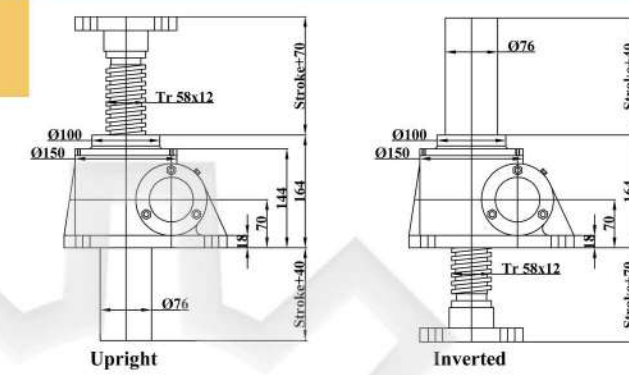

Screw End Types and Dimensions

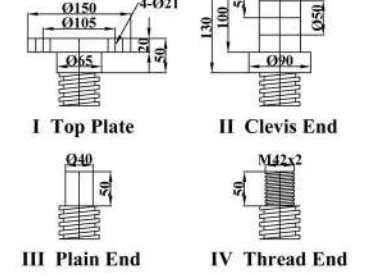

JSS-20T

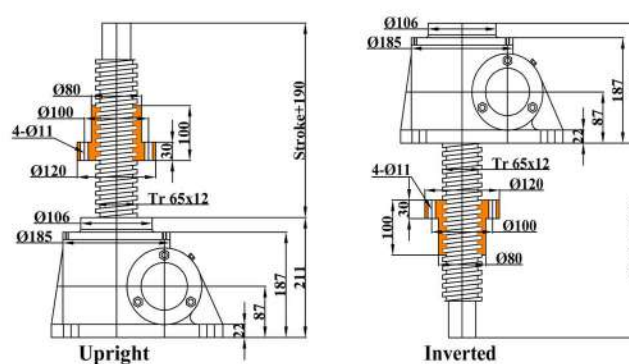
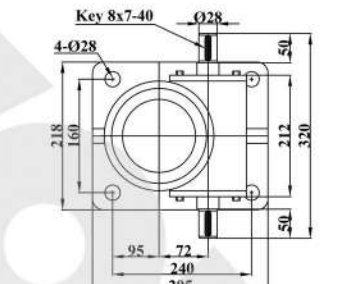
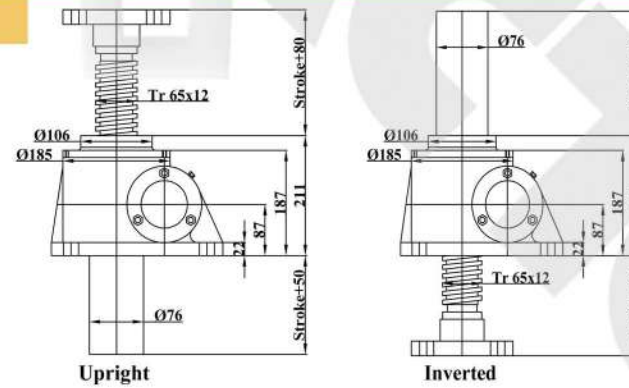

Screw End Types and Dimensions

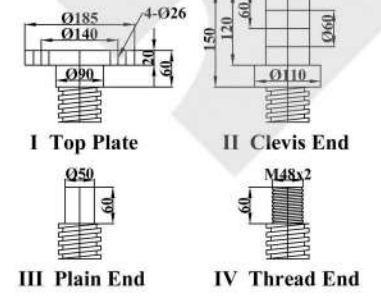

\*. Dimensions are subject to change without notice



**Permitted Lateral Force On the Lifting Screw Fs (N)**

Lateral forces are to be prevented by constructive measures. The Lateral forces on lifting Screws or travelling nuts exercise a reinforced edge compression on the movement thread, leading to increased wear and a shortened service life.



The permitted lateral force (Fs) on the lifting screw depends on the axial force (Fa), the diameter of the screw (d) and the length of the lifting screw L. As compression and buckling force exercise negative influence, these factors were taken into account when determining this permitted lateral force (Fs). The maximum length of the lifting screw (L) is limited by the value generally used in mechanical engineering applications: "unguided lifting screw length = 4x free clamping length".

- Note: Lateral force on the lifting screw is only permitted on screw jacks fitted with **two guide rings**.
- Note: For rotating screw jack, The permitted lateral force (Fs) is in static configuration only.

**For compressive load applications, please use the following diagrams to determine the maximum permitted lateral force.**

JSS-1T(Tr24x4) / JSS-2.5T(Tr30x6)

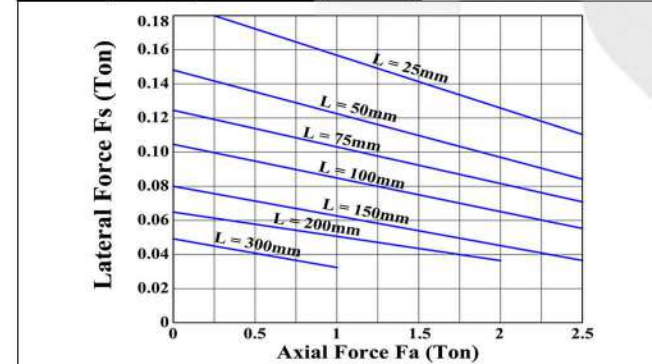

JSS-5T(Tr40x7)

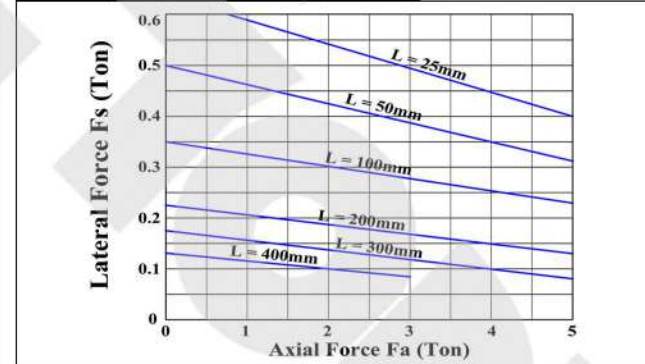

JSS-10T/15T(Tr58x12)

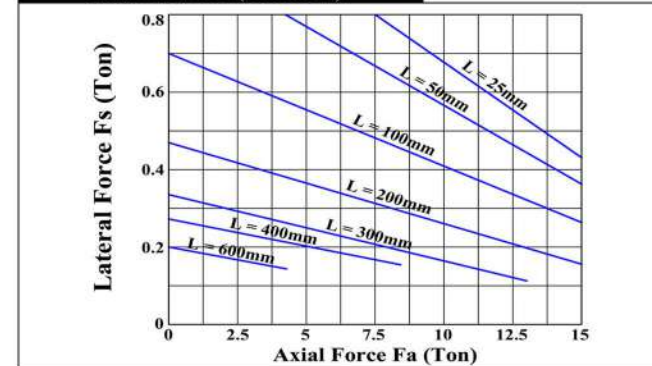

JSS-20T(Tr65x12)

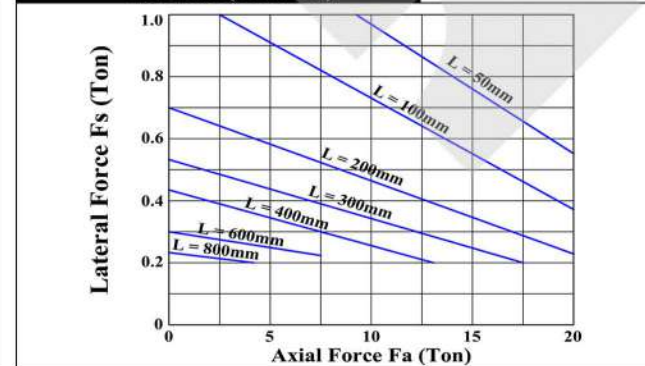

**Permitted Radial Force On Input Shaft Fr (N)**

Toothed and/or chain wheels along with pulley wheels bring radial forces to bear on the drive shaft of the worm gear screw jacks. The maximum permitted value depends on the lifting force and size of the jacking element.

The table is calculated for  $\alpha \sim 30^\circ$  or  $330^\circ$ . This is the least-favorable bearing with respect to application of the lifting force and turning direction.

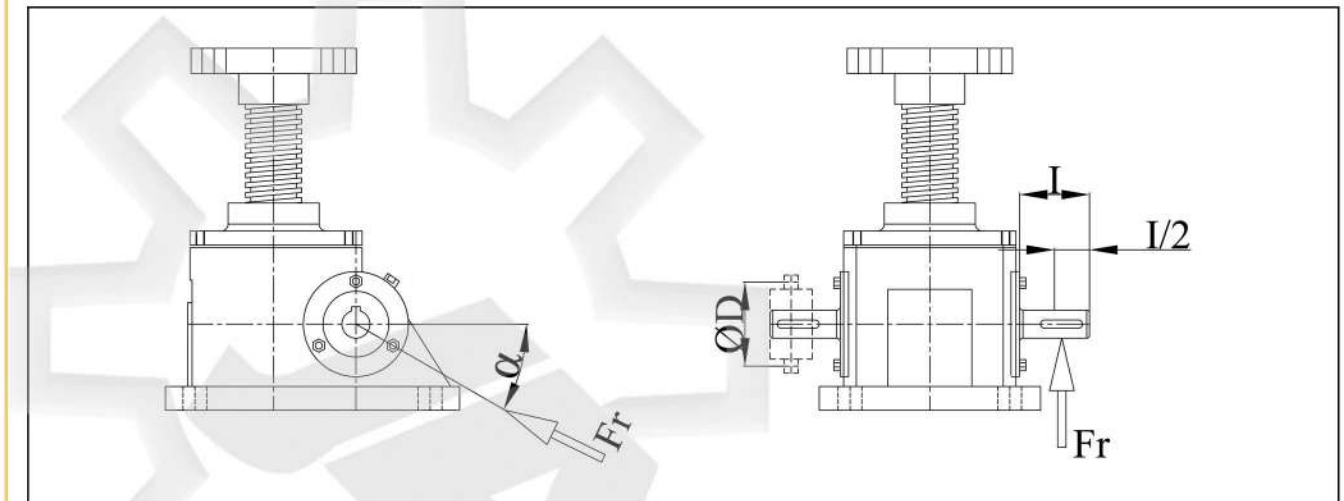

- Permitted radial force (Fr) on application of force in I/2
- Minimum diameter (D) for toothed wheel or pulleys:

$$D_{min} = (19100 \times P) / (Fr \times n) = 2 \times T / Fr$$

P= Power rating (kW) Fr= Max. Radial force (N) n= Input speed (rpm) T= input torque (Nm)

Model	Fr max (N)	T max (Nm)
JSS-1T	350	5.7
JSS-2.5T	350	18
JSS-5T	750	44.2
JSS-10T / 15T	1000	108
JSS-20T	5100	1415