

JT

Spiral Bevel Gearbox

Descriptions	001
Materials	001 - 002
Selection Guide	003 - 006
Calculation Formulas	003
Sample Part Number	004
Radial Force on Shafts	007
Specifications	008 - 009
Overall Dimensions	010 - 017
JT15 - JT19	010
JT25 - JT32	011
JT40 - JT45	012
JT50 - JT60	013
JT72 - JT85	014
JT Gearbox + IEC Motor Flange Input	015
JT Gearbox + IEC Motor	016
JT Gearbox + RV Worm Gear Motor	017
Other Products	019 - 022
Contact Us	023

Contents





Descriptions

JT Series Spiral Bevel Gearbox with the use of high-precision spiral bevel gears, delivers high transmission efficiency and high transfer capacity, high performance, low backlash, smooth rotation, silent drive possible, low running temperature, long life and easy installation. General applications in worm gear screw jack systems, industrial dryers, folding machines, brushing machinery, power transmission equipment, pumps, damper controls, case openers, paper rewinders, test equipment, blowers and fans, unloaders and unscramblers, bottle capping, electroplating machinery, folding machines, food processing equipment, transfer machines, chemical mixers and recording equipment.

Key Features

- Used in pairs case hardened alloy steel spiral bevel gears to transmit rotary motion, mechanical power and torque.
- Gear ratios of 1:1, 1.5:1, 2:1, 2.5:1, 3:1, 4:1 and 5:1 are actual ones.
- Power Ratings up to 335 kW. Torque Ratings up to 5713 N.m.
- Gear transmission average efficiency up to 94%.
- 2-way, 3-way and 4-way Configurations. Allows both horizontal and vertical shafts. Custom 5-way.
- Solid Shaft, Hollow Shaft, and Direct motor mount or via motor flanges.
- Various Shafts Arrangements, Rotation Directions and Mounting Positions available.
- High efficiency, high transmission capacity, low backlash, noiseless operation, low running temperature and long service life.

Ambient Conditions

- Installation site: Indoor
- Ambient temperature: -10°C to 50°C
- Humidity: 95% or less
- Altitude: 1,000 m or lower
- Atmosphere: There shall be no corrosive or explosive gas, vapor, and dew condensation, and there shall be minimal dust.

Materials

We use the best materials to guarantee the performance and lifetime of the bevel gearboxes that you purchased.

Housing:

- HT250 Cast Iron, High-strength Casting housing(JT19 - JT85). Aluminum alloy housing (JT15).

Spiral Bevel Gears

- High purity rugged alloy steel 20CrMnTi, Carburizing and Quenching, Case Hardened and Lapped in Pairs.

Input Shaft and Output Shaft

- Hardened and tempered alloy steel 40Cr as standard. Custom Stainless Steel 304 or 316 (Corrosion-resistant Stainless Steel Gearbox).

Bearing

- Equipped with Tapered Roller Bearings with heavy load capacity. Custom reinforced bearings for higher radial and axial load. Custom corrosion resistant stainless steel bearings.

Oil Seals

- Double-lip Oil Seal, High Dust-proof and Oil leak proof.

Lubricants

- Applications with high speeds and/or high daily duty cycle, Gear oil #320 lubrication is recommended. But applications with low input speed (less than 200rpm) and low daily duty cycle, #0 or #00 lithium grease is recommended.

- Note:** For input speeds 1500 rpm a change in oil level may be required in combination with a breather (vent).

Materials





Selection Guide

Calculation Formulas

■ **(01)** Gear Ratio = Input Speed (rpm) / Output Speed (rpm)

■ **(02)** Required Output Torque (N.m)

- Calculate the Corrected Output Torque (N.m) = Required Output Torque (N.m) x fl
- Calculate the Corrected Output Power (kW) = Required Output Torque (N.m) x Output Speed (rpm) / 9550.
- Calculate the Input Power (kW) = Output Power (kW) / Efficiency (Gearbox efficiency is 95% after initial running in).

The ratings for bevel gearboxes in this catalogue are based on a service factor of 1.00. For other operating conditions, the application power or torque must be multiplied by the appropriate service factor, to determine the equivalent gear drive power rating. A bevel gearbox should be selected with a rated capacity equal to or greater than the equivalent rating. Below table designates recommended Service Factors for various conditions of load, power source, and duration of service.

● **Service Factors fl**

Driven Machine Load Characteristic	Operating Time per Day		
	≤ 2 hours	2-10 hours	10-24 hours
Uniform (Light Shocks)	1.00 (1.00)	1.00 (1.25)	1.25 (1.50)
Medium Shocks	1.00 (1.25)	1.25 (1.50)	1.50 (1.75)
Heavy Shocks	1.25 (1.50)	1.50 (1.75)	1.75 (2.00)

● **Note:** please use these data inside the brackets when “frequent starts and stops” refers to more than 10 starts per hour.

● **Note:** time specified for intermittent and occasional service refers to total operating time per day.

* **Uniform (Light Shocks) driven machine:** generators, conveyor belts, apron conveyor, ventilators, agitators and mixers for uniform densities, filling and packing stations, gear wheel pumps, feed servos of machine tools, filling machines, elevators, light screw conveyors, light conveyor belts, blowers, small agitators, control machines, assembly lines, auxiliary drives for machine tools, centrifuges, packaging machinery.

Selection Guide

* **Medium Shocks driven machine:** lifts, swing gear on cranes, pit ventilators, agitators and mixers for unequal densities, piston pumps, timber processing machines, paper processing machines, winches, auxiliary drives in ships, textile machines, reel winders, plate conveyors, calenders, balancing machines, heavy-duty conveyor belts, sheet metal bending machines, road-building machinery, planing machines, shears, extruders, main drives for machine tools, kneading machines, weaving looms, light table rollers.

* **Heavy Shocks driven machine:** punches, shears, rolling and smelting machines, heavy-duty centrifuges, heavy-duty supply pumps, edge runners, vibrating machines, cutting machines, brick works machines, heavy-duty lifts, excavators, heavy-duty mixers, presses, muller mixers, rolling mills, heavy-duty table rollers, cold reduction mills, stone crushers, eccentric presses, cutter heads, folding machines, rubber belt conveyors (batch loads), bark peeling drums, run ning gears, punching presses, piston pumps, rotary furnaces, mills, plate filters.

■ **(03)** Duty Cycle per Hour (% Running time) = working time (minutes) ÷ 60 minutes

Sample Part Number (Example):

JT25 - 1:1 - 300R - 300R - 1-LR - B3
 (1) (2) (3) (4) (5) (6)

■ **(1) Model & (2) Gear Ratios**

Model	JT15	JT19	JT25	JT32	JT40	JT45	JT50	JT60	JT72	JT85
Input & Output Shafts Dia.(mm)	15	19	25	32	40	45	50	60	72	85
Gear Ratios	1:1, 2:1	1:1, 2:1	1:1, 1.5:1, 2:1, 3:1, 4:1, 5:1	1:1, 1.5:1, 2:1, 3:1, 4:1, 5:1	1:1, 1.5:1, 2:1, 3:1, 4:1, 5:1	1:1, 1.5:1, 2:1, 3:1, 4:1, 5:1	1:1, 1.5:1, 2:1, 3:1, 4:1, 5:1	1:1, 1.5:1, 2:1, 3:1, 4:1, 5:1	1:1, 1.5:1, 2:1, 3:1, 4:1, 5:1	1:1, 1.5:1, 2:1, 3:1, 4:1, 5:1
Max. Torque (N.m)	28	48.5	132	214	361	561	919	1940	3205	5713
Max. Power (kW)	1.79	4.94	14.9	22	45.6	56.3	96	163	234	335
N.W(kg)	3.5	11	22	33	50	80	125	189	299	499

■ **(3) Input Speed & (4) Output Speed, Below is Sample**

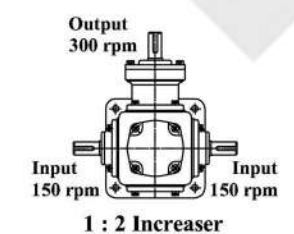
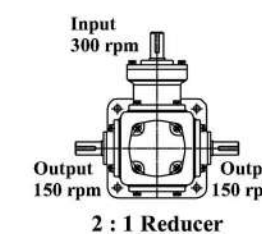
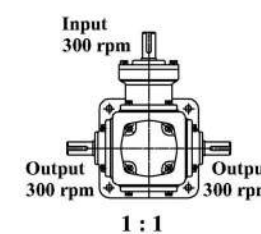



Selection Guide

Sample Part Number

(5) Shaft Arrangements And Rotation Directions

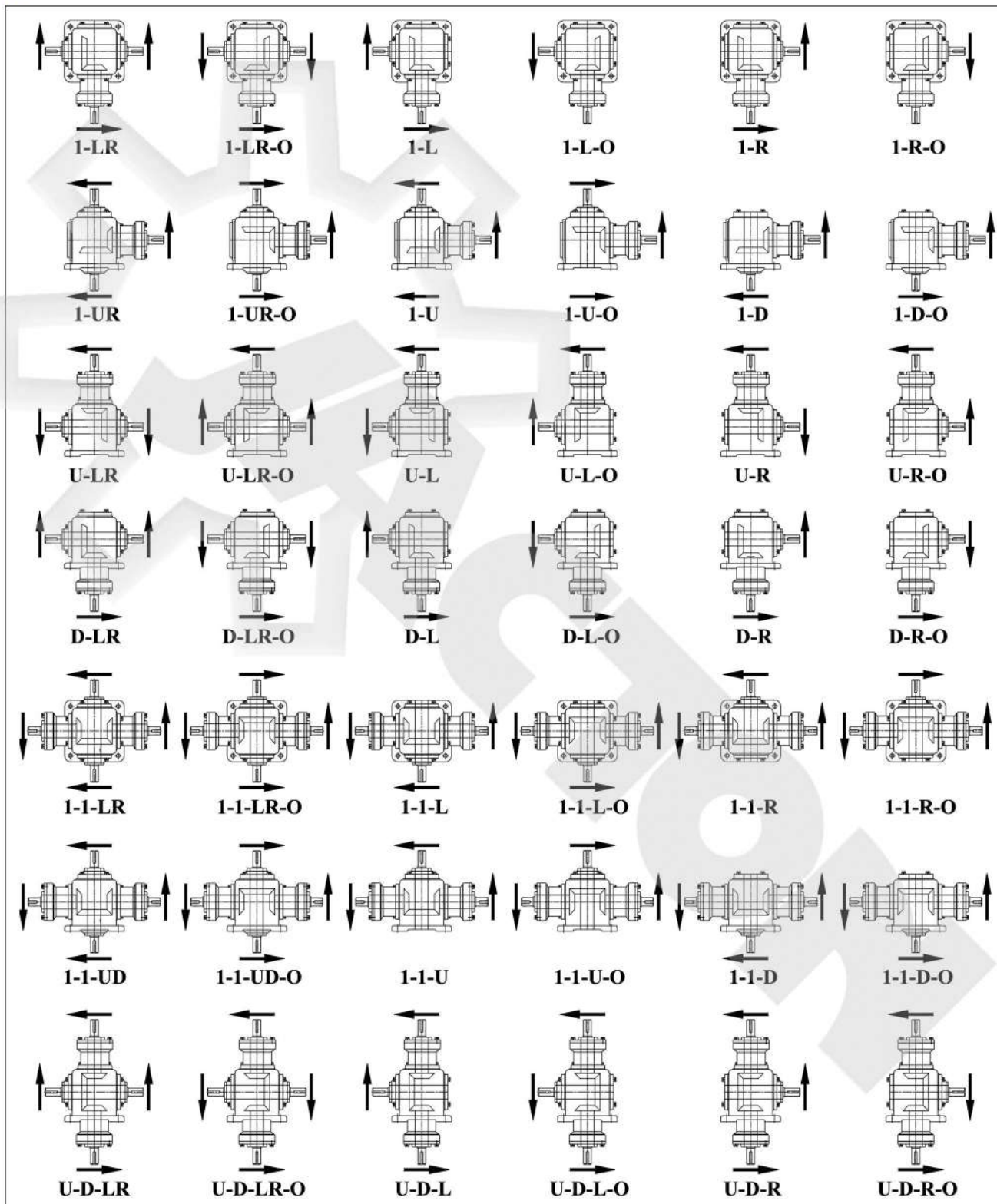

Selection Guide

(6) Mounting Positions

Codes	Horizontal	Over Hung	Side Wall
1-LR 1-LR-O 1-R 1-R-O 1-L 1-L-O	B3	B8	V5
1-UD 1-UD-O 1-U 1-U-O 1-D 1-D-O	B3	B8	V5
U-LR U-LR-O U-R U-R-O U-L U-L-O	B3	B8	V5
D-LR D-LR-O D-R D-R-O D-L D-L-O	B3	B8	V5
1-1-LR 1-1-LR-O 1-1-R 1-1-R-O 1-1-L 1-1-L-O	B3	B8	V5
1-1-UD 1-1-UD-O 1-1-U 1-1-U-O 1-1-D 1-1-D-O	B3	B8	V5
U-D-LR U-D-LR-O U-D-R U-D-R-O U-D-L U-D-L-O	B3	B8	V5



Radial Force on Shafts

• **Remarks:** 1) Radial Force on Shafts (Fr)(N) 2) IS = Input Shaft 3) OS = Output Shaft

Ratio	n1 (r/min)	JT15		JT19		JT25		JT32		JT40	
		IS	OS	IS	OS	IS	OS	IS	OS	IS	OS
1 : 1	1450	265	216	833	951	1911	2450	2450	3136	3234	3381
	1150	323	235	882	1029	2058	2597	2744	3234	3479	3626
	870	402	255	960	1127	2205	2842	2989	3381	3773	3969
	580	549	314	1078	1323	2499	3185	3381	3822	4263	4459
	400	637	353	1372	1715	3185	3528	4018	4900	4851	5978
	300	696	392	1519	1960	3430	3528	4410	5537	5243	6958
	200	784	441	1911	1960	3430	3528	5096	6272	7889	8820
	100	980	588	1911	1960	3430	3528	5096	6272	8428	8820
	10	980	588	1911	1960	3430	3528	5096	6272	8428	8820
1.5 : 1	1450			1078	1960	2548	2842	3430	5390	4361	7987
	1150			1078	1960	3038	3087	4067	5978	5096	8820
	870			1078	1960	3430	3332	4753	6076	6076	8820
	580			1078	1960	3430	3528	5096	6174	7644	8820
	400			1078	1960	3430	3528	5096	6272	8428	8820
	300			1078	1960	3430	3528	5096	6272	8428	8820
	200			1078	1960	3430	3528	5096	6272	8428	8820
	100			1078	1960	3430	3528	5096	6272	8428	8820
	10			1078	1960	3430	3528	5096	6272	8428	8820

Ratio	n1 (r/min)	JT45		JT50		JT60		JT72		JT85	
		IS	OS	IS	OS	IS	OS	IS	OS	IS	OS
1 : 1	1450	4165	4508	5096	5586	10633	10976				
	1150	4459	4851	5488	6076	11368	11760	15386	15608		
	870	4851	5292	5880	6566	12446	12740	16660	17150	24794	25480
	580	5488	5880	6713	7301	14014	14504	18816	19404	28028	28910
	400	6272	7056	7742	8134	15680	16170	21070	21756	31360	32340
	300	6713	7987	8232	9065	17150	17640	23422	24108	34300	35280
	200	8575	9604	9261	10290	19600	19894	25970	26754	38612	39788
	100	9996	11760	11368	12593	22540	22540	28420	32928	39200	49000
	10	9996	11760	11858	14504	22540	22540	28420	33320	39200	49000
1.5 : 1	1450	5194	9212	5978	10486	5978	12152	7693	14602		
	1150	6174	10486	7252	12152	6419	13083	8771	17934	12985	24647
	870	7448	11760	8869	14504	6958	14210	9506	19453	13573	29400
	580	9555	11760	11466	14504	7840	16072	10780	22001	15680	33222
	400	9996	11760	11858	14504	8820	17934	12005	24598	17542	37142
	300	9996	11760	11858	14504	9604	19600	13132	27342	19159	40474
	200	9996	11760	11858	14504	10829	22148	14798	30282	21658	45766
	100	9996	11760	11858	14504	13328	22540	18228	33320	26656	49000
	10	9996	11760	11858	14504	22540	22540	28420	33320	39200	49000

Specifications

Model	Input Speed (RPM)	1:1		1.5:1		2:1		2.5:1		3:1		4:1		5:1	
		N.m	kW	N.m	kW	N.m	kW	N.m	kW	N.m	kW	N.m	kW	N.m	kW
JT15	1450	11.6	1.79			12.1	0.94								
	1150	11.7	1.43			12.0	0.74								
	870	12.1	1.12			12.0	0.56								
	580	12.1	0.747			11.9	0.37								
	400	12.3	0.524			12.2	0.26								
	300	12.3	0.396			11.9	0.19								
	200	12.4	0.226			12.2	0.13								
	100	12.7	0.136			11.2	0.06								
	10	13.0	0.014			28.1	0.015								
JT19	1450	31.9	4.94			42.8	3.32								
	1150	34.1	4.19			43.4	2.67								
	870	37.2	3.46			43.8	2.04								
	580	39.5	2.45			44.4	1.38								
	400	40.2	1.72			45.1	0.96								
	300	40.5	1.30			45.5	0.73								
	200	41.2	0.880			46.1	0.49								
	100	41.9	0.448			46.6	0.25								
	10	43.0	0.046			48.5	0.026								
JT25	1450	96.0	14.9	117	12.1	102	7.90	96.2	5.97	93.6	4.84	80.6	3.12	52.0	1.61
	1150	103	12.7	122	9.96	104	6.39	97.2	4.78	94.8	3.88	81.5	2.50	52.5	1.29
	870	113	10.5	123	7.66	105	4.88	99.0	3.68	95.9	2.97	82.4	1.92	53.2	0.99
	580	119	7.35	126	5.23	108	3.34	100.0	2.48	97.6	2.02	84.1	1.3	54.2	0.67
	400	122	5.20	128	3.66	109	2.33	100.9	1.73	99.0	1.41	85.1	0.91	52.9	0.47
	300	123	3.93	129	2.77	110	1.76	102.9	1.32	100	1.07	86.1	0.69	55.5	0.36
	200	124	2.66	131	1.87	111	1.18	103.9	0.888	100	0.712	86	0.46	55.4	0.24
	100	127	1.36	134	0.957	114	0.608	104.9	0.448	102	0.363	87.7	0.23	56.5	0.12
	10	132	0.141	139	0.099	116	0.063	107.8	0.046	104	0.037	89.3	0.02	57.6	0.01
JT32	1450	142	22.0	145	15.0	137	10.6	113	6.99	105	5.42	93.4	3.62	57.4	1.78
	1150	150	18.4	147	12.0	139	8.55	115	5.64	106	4.34	94.3	2.90	58.0	1.43
	870	164	15.2	150	9.30	141	6.56	116	4.30	108	3.34	95.9	2.23	59.0	1.10
	580	184	11.4	153	6.32	144	4.47	118	2.92	109	2.25	96.9	1.50	59.6	0.74
	400	195	8.34	155	4.41	146	3.12	120	2.05	111	1.58	98.7	1.05	60.7	0.52
	300	198	6.35	157	3.35	148	2.37	121	1.55	111	1.18	98.3	0.79	60.4	0.39
	200	201	4.3	160	2.28	149	1.59	123	1.05	113	0.803	101	0.54	61.7	0.26
	100	206	2.2	163	1.16	152	0.812	123	0.528	115	0.409	101	0.27	62.9	0.13
	10	214	0.228	169	0.12	157	0.084	126	0.054	118	0.042	101	0.03	64.5	0.01
JT40	1450	294	45.6	185	19.1	180	14.0	184	11.4	159	8.20	127	4.80	68.7	2.13
	1150	305	37.5	188	15.4	183	11.3	185	9.11	160	6.55	125	3.83	69.2	1.70
	870	312	29.0	191	11.8	187	8.70	188	7.00	163	5.04	127	2.95	70.4	1.31
	580	319	19.8	197	8.14	191	5.92	192	4.76	166	3.42	129	2.00	71.7	0.89
	400	326	14.0	200	5.70	194	4.15	195	3.34	168	2.39	131	1.40	72.6	0.62
	300	331	10.6	203	4.34	196	3.14	197	2.53	169	1.80	131	1.05	72.9	0.47
	200	338	7.23	204	2.91	198	2.12	200	1.71	171	1.22	134	0.71	74.1	0.32
	100	346	3.70	210	1.49	202	1.08	203	0.867	173	0.618	135	0.36	75.1	0.16
	10	361	0.386	218	0.155	209	0.122	208	0.089	179	0.064	140	0.04	77.8	0.02



Specifications

Model	Input Speed (RPM)	1:1		1.5:1		2:1		2.5:1		3:1		4:1		5:1	
		N.m	kW	N.m	kW	N.m	kW	N.m	kW	N.m	kW	N.m	kW	N.m	kW
JT45	1450	421	65.3	374	38.7	305	23.6	293	18.2	270	14.0	241	9.35	136	4.21
	1150	453	55.7	380	31.2	309	19.0	298	14.7	279	11.3	246	7.54	138	3.39
	870	479	44.6	389	24.1	315	14.6	302	11.2	279	8.66	249	5.78	140	2.60
	580	493	30.6	396	16.4	322	10.0	310	7.68	285	5.89	254	3.93	143	1.77
	400	504	21.5	406	11.6	328	7.02	315	5.38	288	4.11	257	2.74	144	1.23
	300	513	16.4	411	8.78	332	5.33	317	4.06	291	3.11	259	2.08	146	0.93
	200	521	11.1	417	5.95	338	3.61	321	2.75	294	2.10	262	1.40	148	0.63
	100	535	5.72	426	3.04	334	1.84	326	1.40	300	1.07	267	0.71	150	0.31
	10	561	0.599	443	0.316	357	0.191	336	0.144	308	0.11	275	0.07	155	0.03
JT50	1450	619	96.0	564	58.3	516	40.0	507	31.4	458	23.6	434	13.8	296	9.18
	1150	665	81.1	601	49.2	516	31.7	514	25.3	464	19.0	441	13.5	301	7.39
	870	726	67.5	656	40.7	516	24.0	523	19.5	469	14.6	448	10.4	305	5.68
	580	802	49.7	699	28.9	524	16.3	535	13.3	480	9.92	456	7.07	311	3.86
	400	821	35.1	711	20.3	538	11.5	545	9.32	490	6.98	456	4.97	318	2.72
	300	835	26.8	724	15.5	543	8.71	552	7.08	495	5.29	470	3.77	321	2.06
	200	852	18.2	736	10.5	551	5.89	560	4.79	501	3.57	476	2.54	325	1.39
	100	875	9.36	754	5.37	563	3.01	568	2.43	510	1.82	485	1.30	331	0.71
	10	919	0.983	785	0.56	586	0.313	588	0.251	527	0.188	501	0.13	342	0.07
JT60	1450	1019	163			921	73.7			904	48.2	850	34.3	814	26.3
	1150	1098	139			938	59.5			920	38.9	865	27.7	828	21.2
	870	1186	114			958	46.0			940	30.1	884	21.4	847	16.4
	580	1343	85.9			980	31.3			960	20.4	902	14.6	864	11.2
	400	1499	66.1			1000	22.0			978	14.4	919	10.2	881	7.85
	300	1637	54.1			1009	16.7			990	10.9	930	7.8	891	5.96
	200	1784	39.3			1029	11.3			1005	7.38	944	5.3	905	4.03
	100	1842	20.3			1058	5.84			1038	3.82	976	2.7	935	2.08
	10	1940	2.14			1098	0.605			1076	0.40	1011	0.3	969	0.22
JT72	1450					1578	126			1529	82.3	1452	58.7	1391	44.9
	1150	1842	234			1607	102			1561	66.6	1482	47.5	1420	36.4
	870	2009	193			1646	79.0			1598	51.6	1518	36.8	1454	28.2
	580	2274	145			1695	54.2			1644	35.4	1562	25.2	1496	19.3
	400	2538	112			1725	38.0			1672	24.8	1588	17.7	1521	13.6
	300	2744	90.8			1754	29.0			1701	18.9	1616	13.5	1548	10.3
	200	3126	69.0			1784	19.7			1733	12.9	1646	9.17	1577	7.03
	100	3205	35.3			1833	10.1			1777	6.60	1688	4.70	1617	3.60
	10	3205	3.53			1921	1.06			1865	0.69	1772	0.49	1697	0.38
JT85	1450									2935	158	2798	113	2631	85.0
	1150					3146	199			3045	130	2892	92.6	2771	71.0
	870	3489	335			3224	155			3135	101	2978	72.2	2853	55.3
	580	3940	252			3332	107			3246	69.9	3084	49.8	2954	38.2
	400	4410	195			3420	75.4			3317	49.3	3151	35.1	3018	26.9
	300	4792	159			3479	57.5			3372	37.6	3204	26.8	3069	20.5
	200	5390	119			3557	39.2			3449	25.6	3276	18.2	3138	14.0
	100	5439	60.0			3646	20.1			3537	13.1	3360	9.36	3218	7.17
	10	5713	6.30			3822	2.11			3713	1.40	3527	0.98	3378	0.75

Overall Dimensions

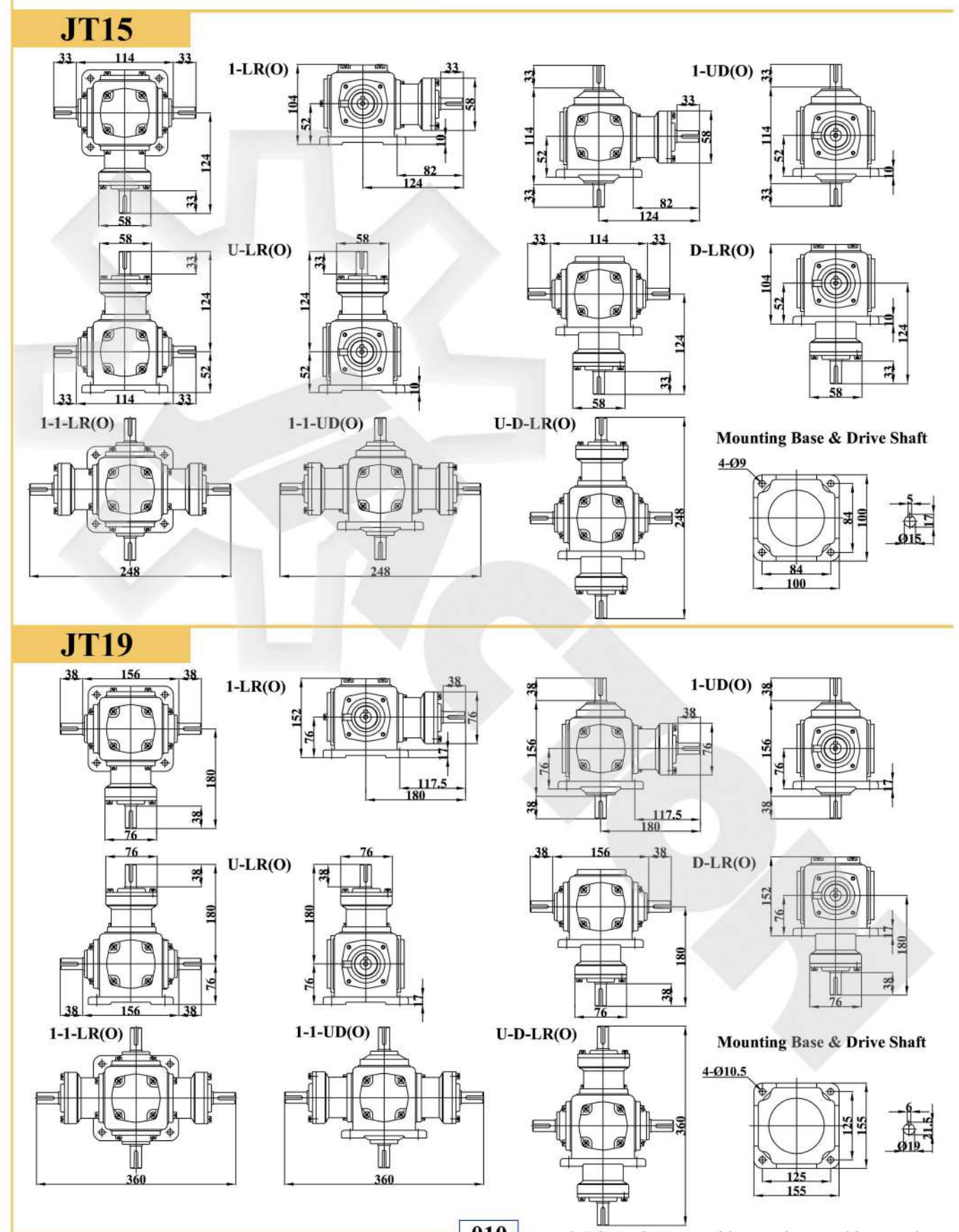

*. Dimensions are subject to change without notice



Overall Dimensions

JT25

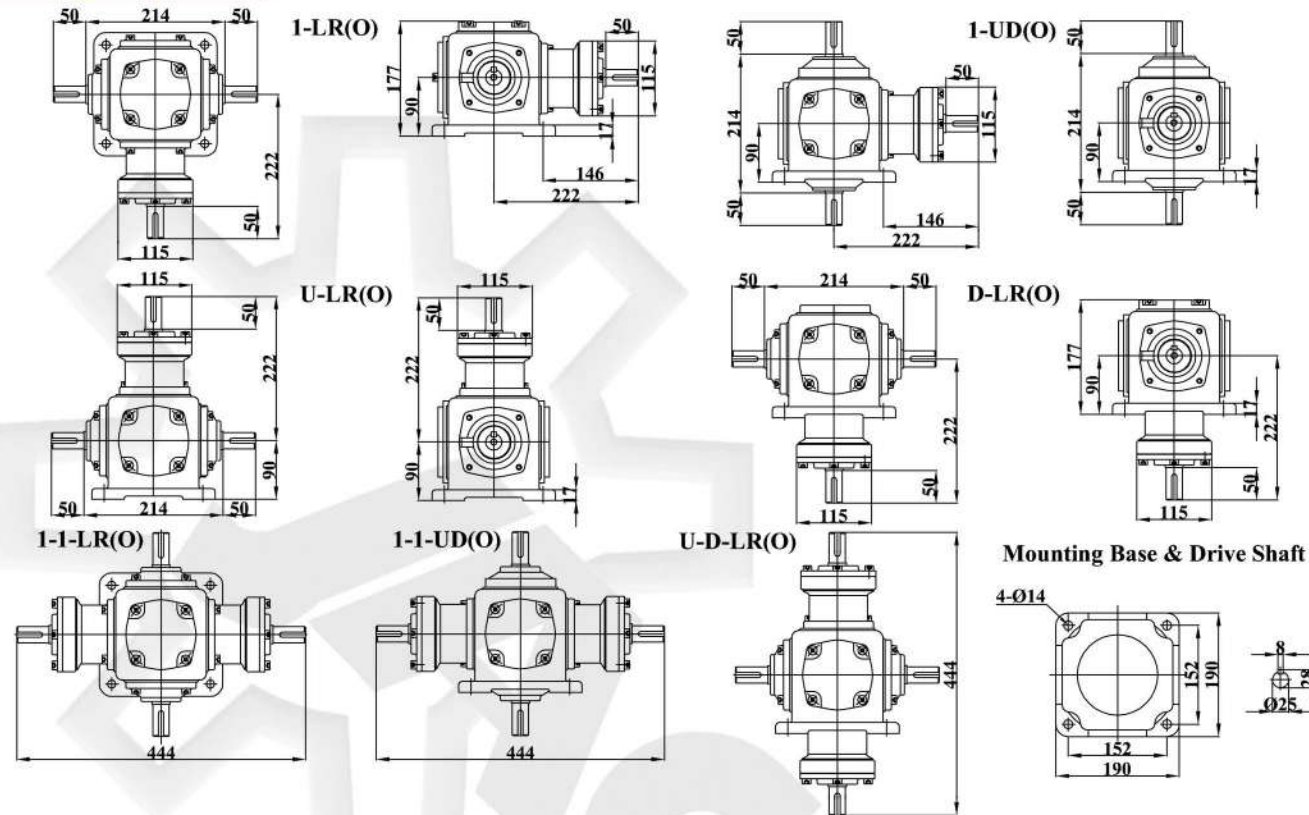

Overall Dimensions

JT40

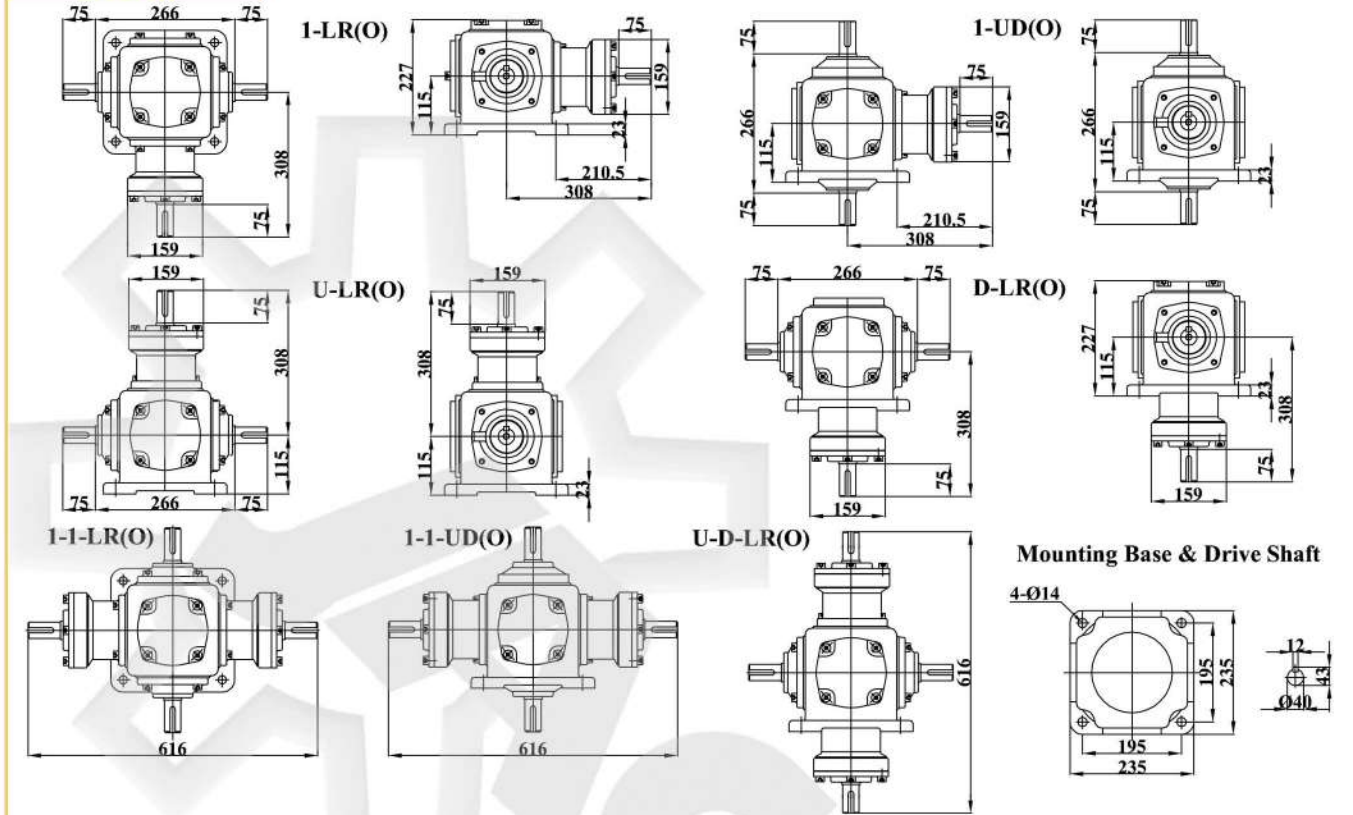

JT32

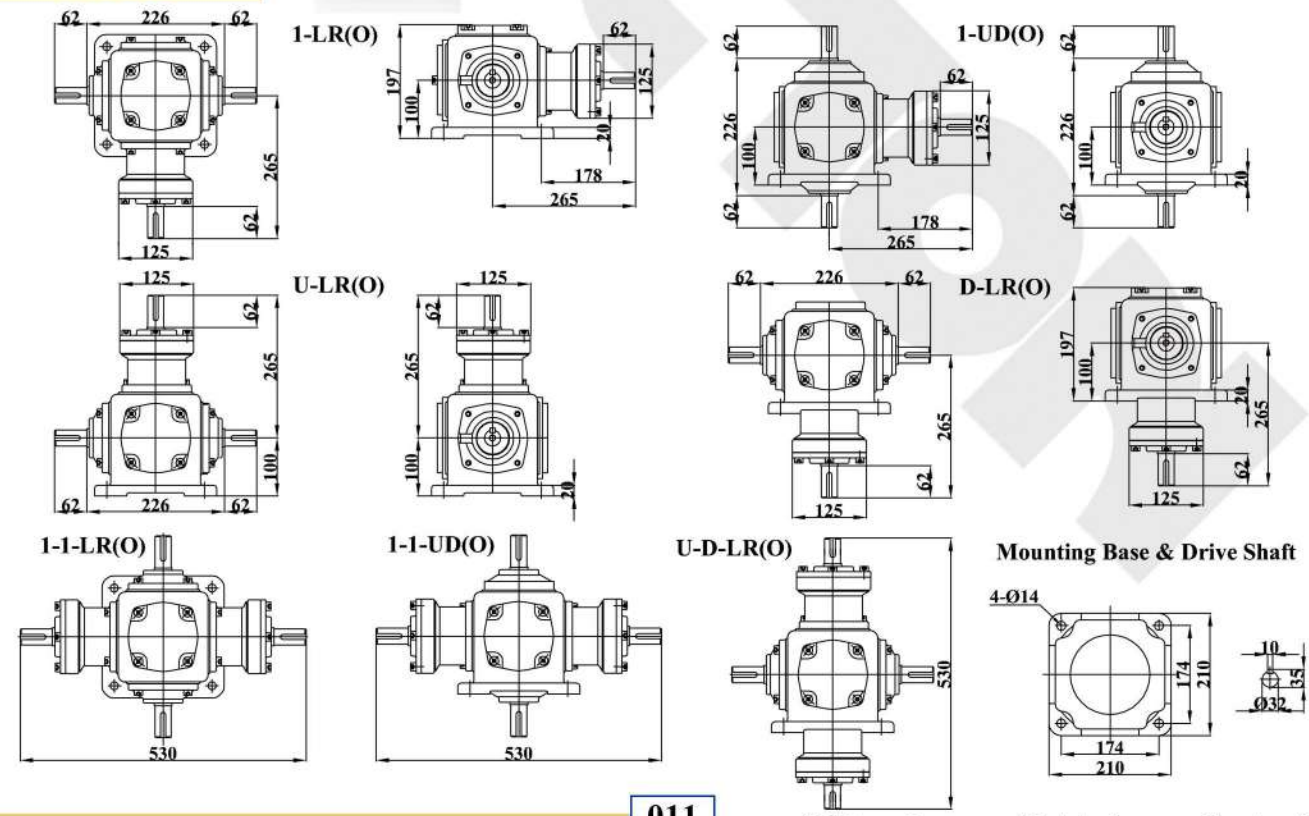

JT45

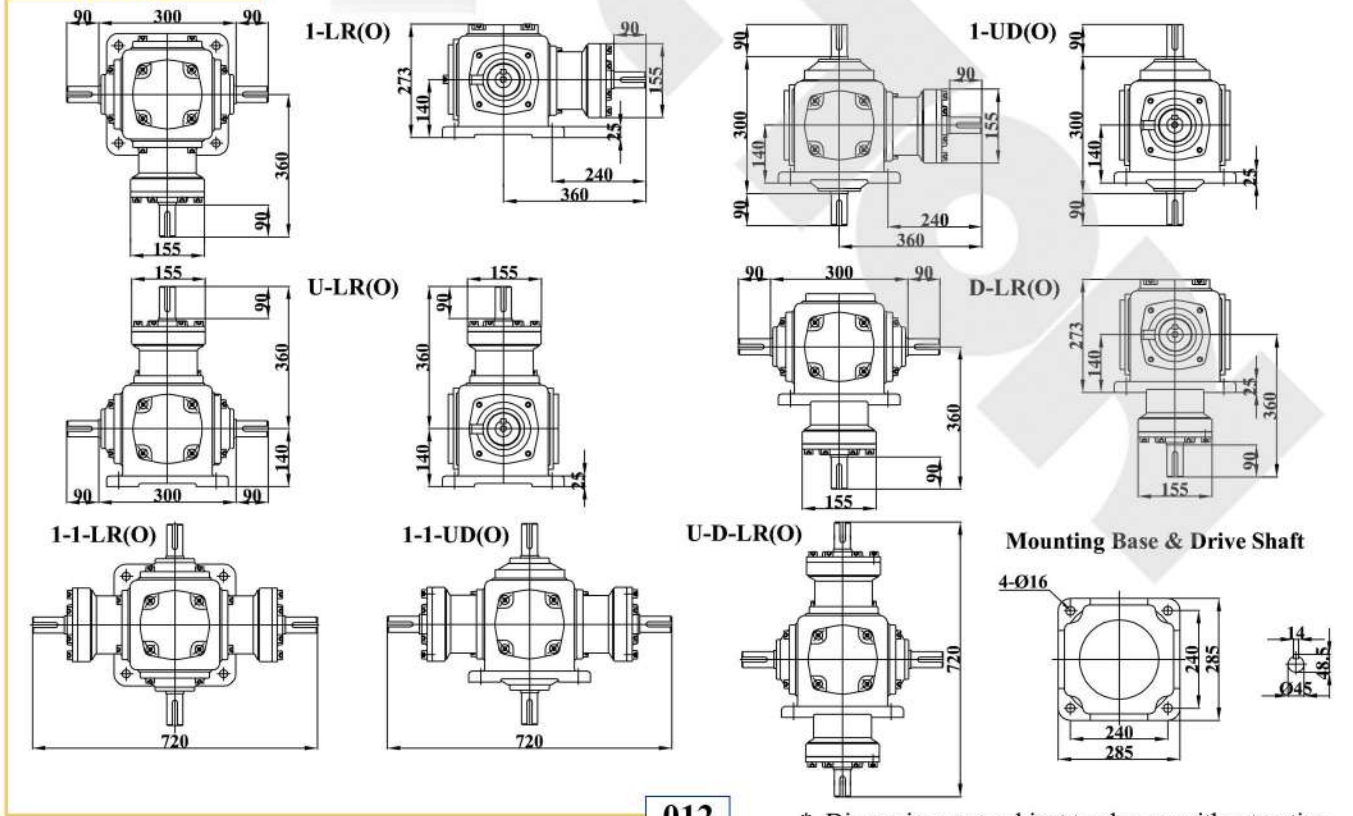



Overall Dimensions

JT50

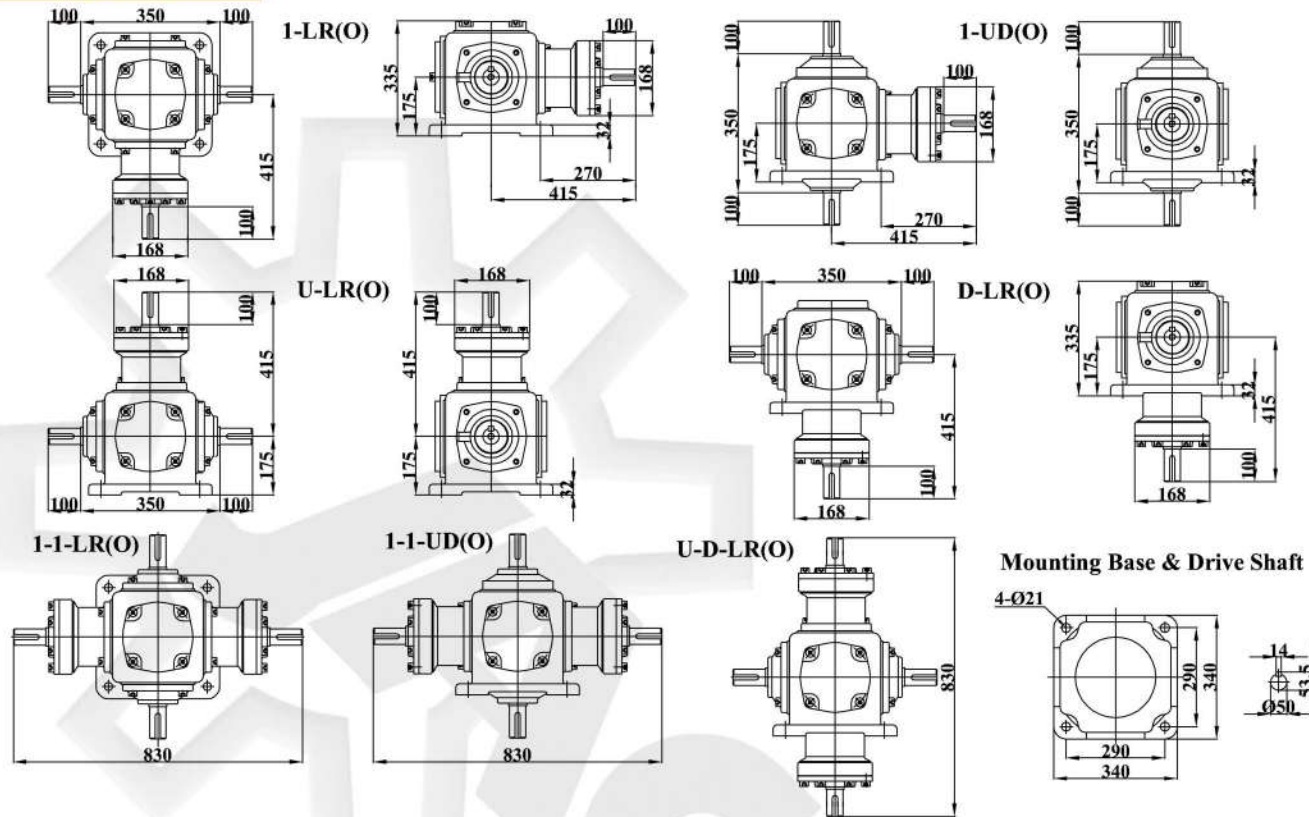

Overall Dimensions

JT72

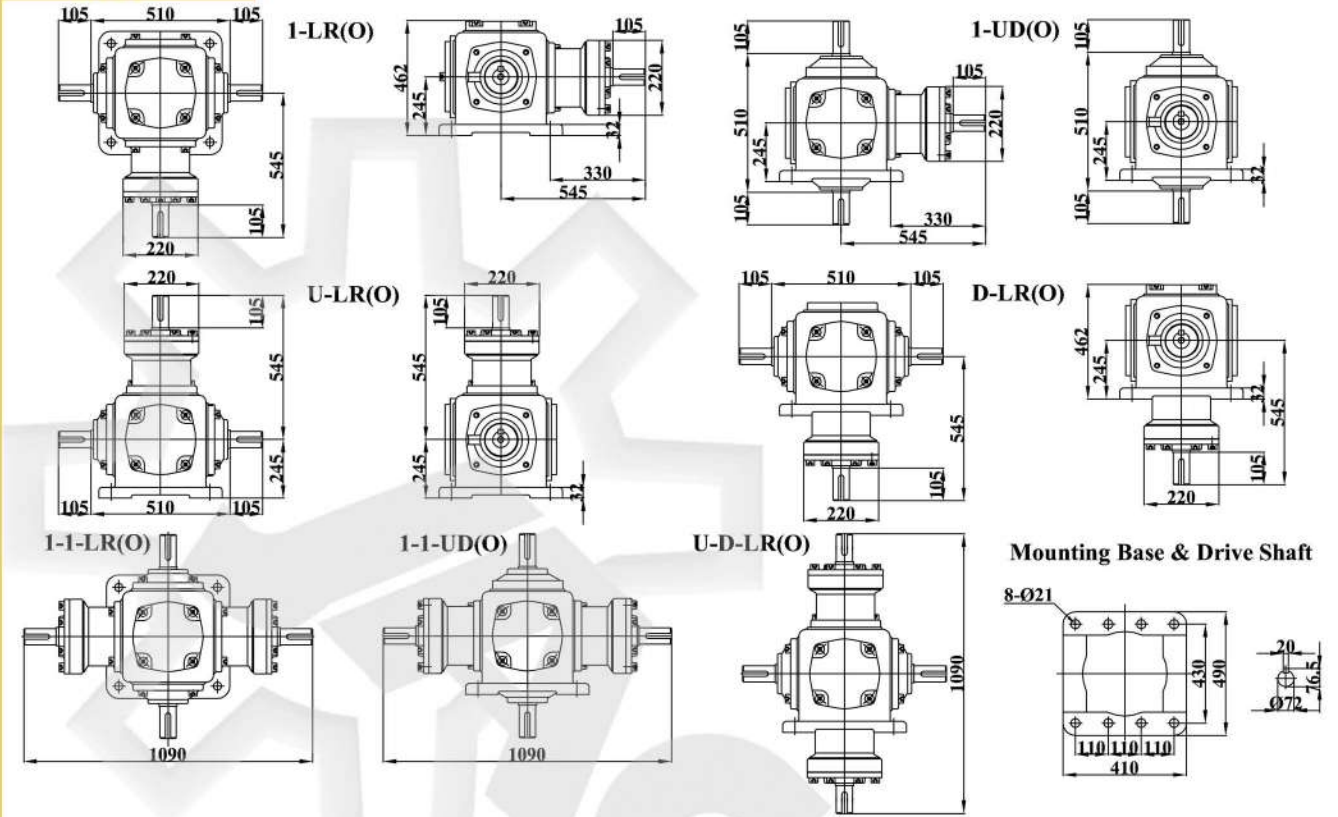

JT60

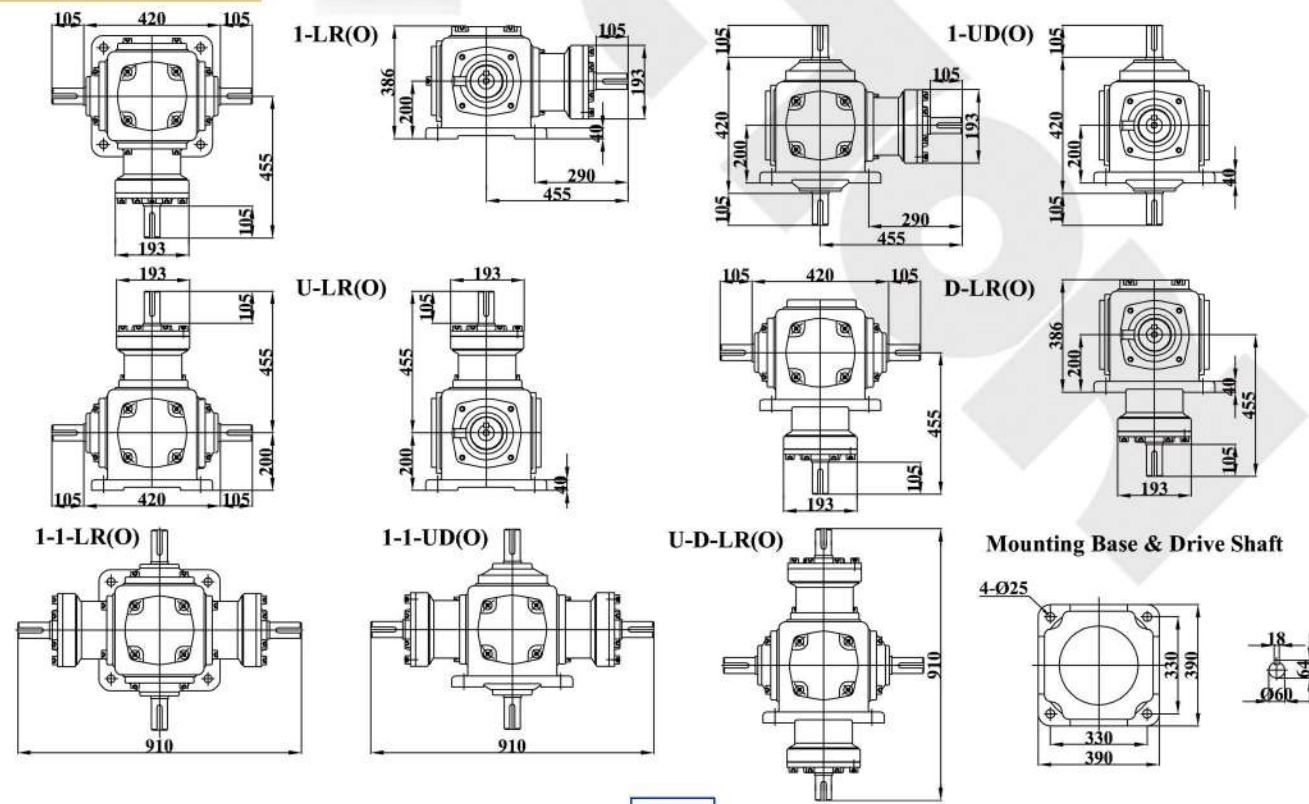

JT85

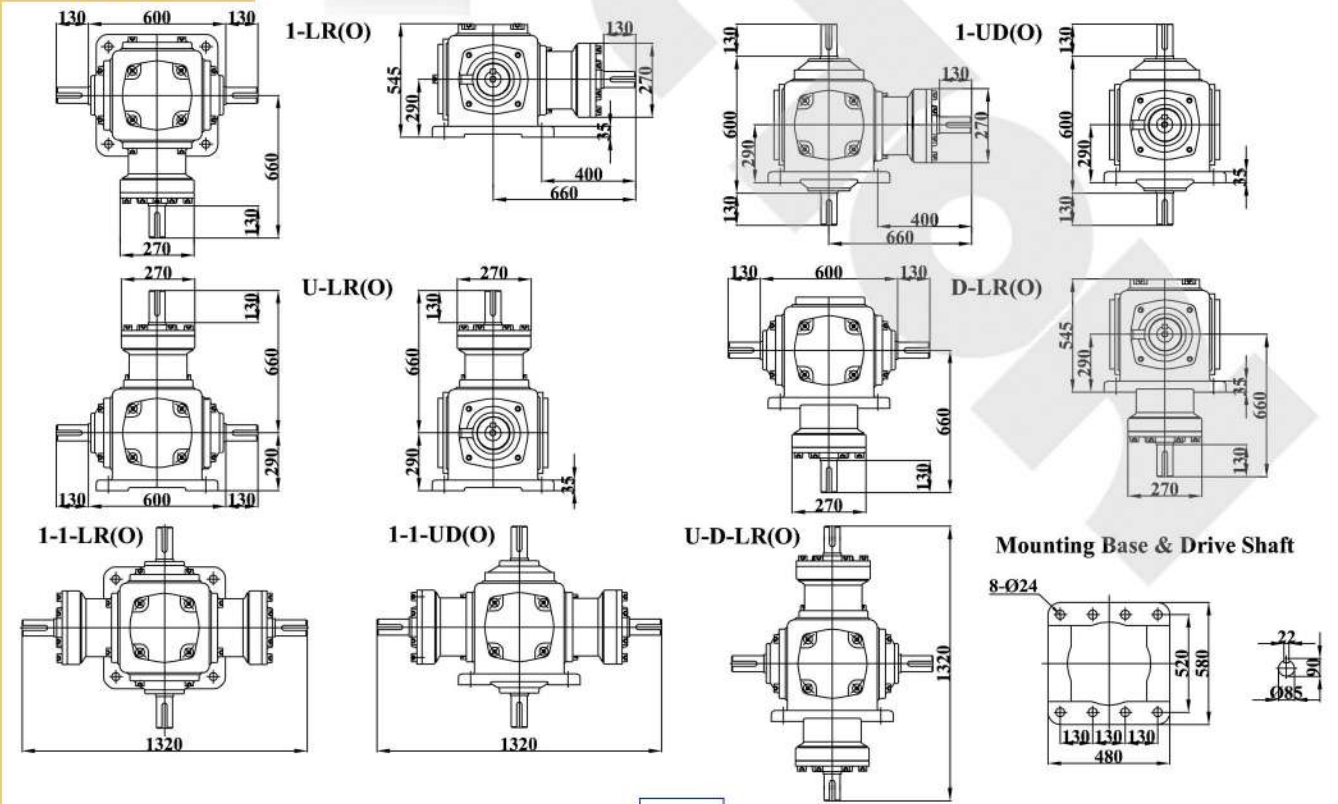



Overall Dimensions

JT Gearbox + IEC Motor Flange Input

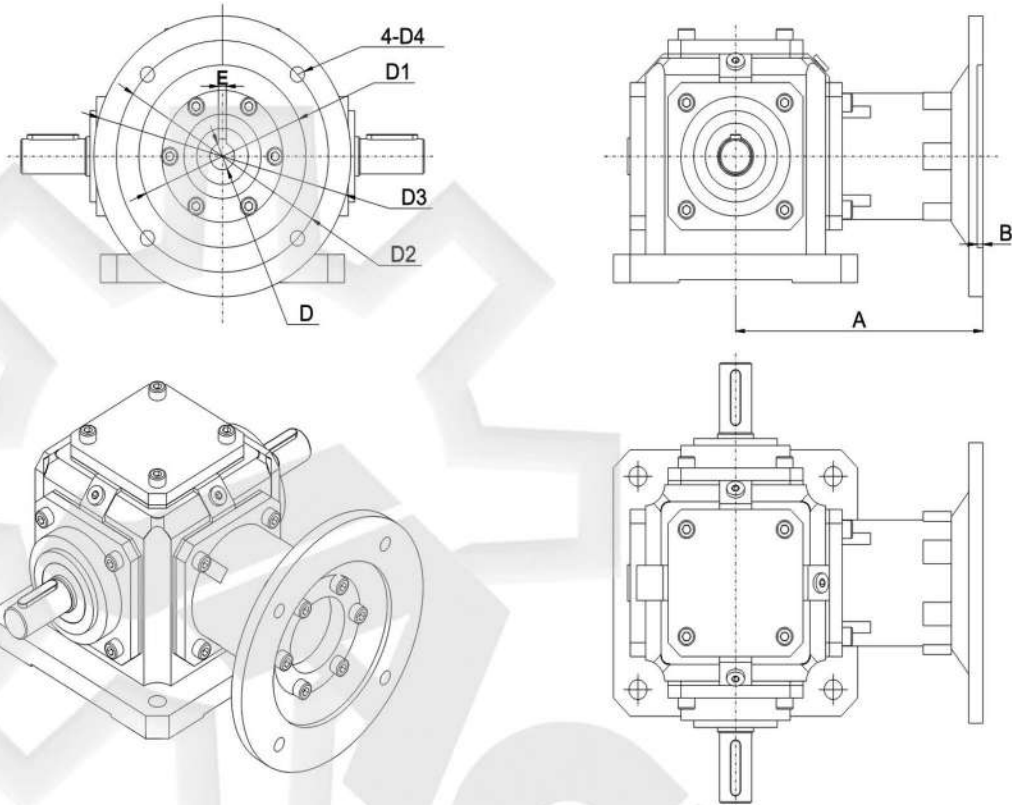

• **Note:** Only suitable for 1:1 ratio gearboxes

Model	Dimensions								
	Input	A	B	D	D1	D2	D3	D4	E
JT19	71B5	154	7	14	110	130	160	9	5
	71B14	154	6	14	70	85	105	6.6	5
	80B5	154	7	19	130	165	200	11	6
	80B14	154	4	19	80	100	120	6.6	6
JT25	80B5	192.5	4.5	19	130	165	200	11	6
	80B14	192.5	6	19	80	100	120	6.6	6
	90B5	192.5	4.5	24	130	165	200	11	8
	90B14	192.5	6	24	95	115	140	9	8
JT32	90B5	231	4.5	24	130	165	200	11	8
	90B14	231	6	24	95	115	140	9	8
	100B5	231	6	28	180	215	250	13.5	8
	100B14	231	7	28	110	130	160	9	8
JT40	100B5	273	6	28	180	215	250	13	8
	112B5	273	6	28	180	215	250	13	8
JT45	112B5	307	6	28	180	215	250	13	8
	132B5	307	6	38	230	265	300	13	10

Overall Dimensions

JT Gearbox + IEC Motor

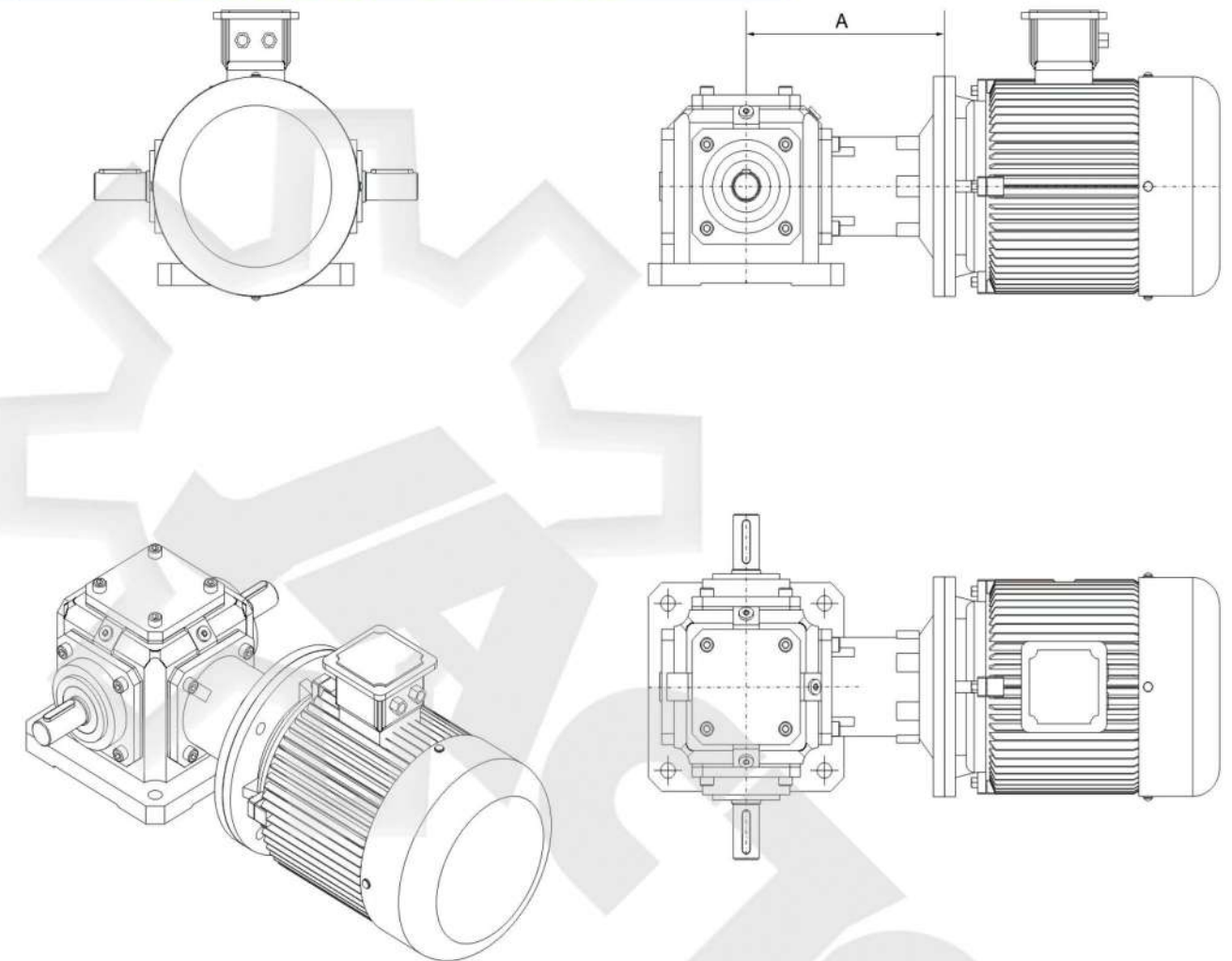

• **Note:** Only suitable for 1:1 ratio gearboxes

Model	+	Motor Power (4pole Motor)				A
		0.25KW	0.37KW	0.55KW	0.75KW	
JT19	+	0.25KW	0.37KW	0.55KW	0.75KW	154
JT25	+	0.55KW	0.75KW	1.1KW	1.5KW	192.5
JT32	+	1.1KW	1.5KW	2.2KW	3KW	231
JT40	+	2.2KW	3KW	4KW		273
JT45	+	3KW	4KW	5.5KW	7.5KW	307

