

# JTE

## Electric Cylinder

2D/3D  
CAD

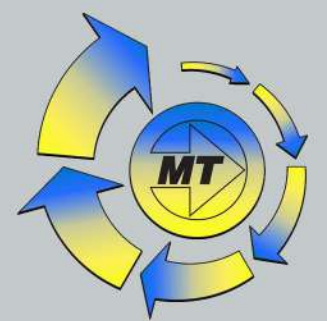

<b>Descriptions</b>	<b>001 - 002</b>
<b>Materials</b>	<b>003</b>
<b>Selection Guide</b>	<b>004 - 008</b>
Selection Notes	004
Unit Converter	005
Sample Part Number	006
<b>Permissible Buckling Load</b>	<b>009</b>
<b>Specifications</b>	<b>010</b>
<b>Overall Dimensions</b>	<b>011 - 012</b>
JTE-2.5T ~ JTE-5T	011
JTE-10T ~ JTE-20T	012
<b>Other Products</b>	<b>013 - 016</b>
<b>Contact Us</b>	<b>017</b>

Contents





## Descriptions

**JTE Series Electric Cylinders** basically screw jacks with travelling nut, but with lifting cylinder design. Combined the advantages of Linear actuator and Screw Jack to achieve the high load lifting in industry application. Available in Ball Screw and Acme Screw. The screw is fully enclosed by push rod which is guided in external protection tube, that is well suited for industrial environments where protection of the lifting screw mechanism and dependable operation are critical, and the protection level can reach IP55, IP56. As a better choice over hydraulic actuators or pneumatic cylinders with this clean alternative, easy to install, control, low maintenance and a quieter solution. In the absence of vibration load, Electric Cylinder with acme screw has self-locking and precisely position loads, will hold loads without backdriving. But Ball Screw Electric Cylinder has not self-locking, brake motor is required.

Electric Cylinder Actuators lift and precisely position up to 20 tons. They are widely application in tunnel freezers, frying machine, polysilicon ingot furnace, monocrystalline silicon in the photovoltaic industry, vehicle lifters in the vehicle manufacturing industry, flexible tooling and welding lifts, medical devices, woodworking machinery, food machinery, aerospace, defense military, and astronomical telescopes remote control actuators.

The JTE Series Electric Cylinder can be ordered to accept the motor type of your choice, whether geared motor, or AC motor etc. Available in Standard(double input shafts), Direct Motor Mounts and Parallel Motor Mounts with additional Gearbox.



### Key Features

- Available in Acme Screw and Ball Screw, precise positioning, and uniform speed.
- Load capacity range from 2.5 ton to 20 ton.
- There are no "standard" travel lengths. each electric cylinder is built to specification.
- Machine Screw Ends: Threaded End, Top Plate, Clevis End, Rod End, and Fork Head.
- Can be operated by manually operated or by electrically driven.
- Double seal to prevent abrasive particles and contaminants from entering the actuator critical mechanisms, and assures trouble-free operation even in most severe environments.
- Standard Electric Cylinders are purchased without a motor or external gearbox (reducer).
- NOTE:** Brake motors must be specified for all Ball Screws Electric Cylinders. and for any Acme Screw Electric Cylinder with an efficiency ratio greater than or equal to 30%.

## Descriptions

### Applications of Synchronized Lifting

Jacton Industry provided complete lifting system design and components, Which including Actuator, motor, bevel gearbox, connecting shaft, coupling, brake, clutch etc. Customer just need let us know your requirement of total load capacity, speed, stroke and dimension, Our engineering will provided you a design scheme with calculation process and components selection, CAD drawing is also available.

#### • Synchronized Lifting System of Two Actuators



#### • Synchronized Lifting System of Four Actuators





### Materials

We use the best materials to guarantee the performance and lifetime of the Electric Cylinders you purchased.

#### Housing

High-strength Casting Housing, Ductile Iron. Custom Stainless Steel 304.

#### Translating Tube(Push Rod)

High strength steel. Custom Stainless Steel 304 or 316.

#### External Protection Tube

High strength steel. Custom Stainless Steel 304 or 316.

#### Acme Screw

C45 Steel as Standard. Custom Stainless Steel 304 or 316.

#### Input Shaft (Worm)

C45 Steel in high frequency heat treatment process. Custom Stainless Steel 304 or 316.

#### Worm Gear / Travelling Nut

High strength ZQAI9-4 (Casting aluminum bronze) as Standard.  
Custom ZCuSn10Pb1(Casting tin bronze).

#### Bearing

Anti-friction Ball Thrust Bearings for Worm Gear. Anti-friction Ball Bearings for Input Shaft(worm).  
Custom Stainless Steel 304.

#### Motor Flange Adapter

High-strength Casting Motor Adapter, Ductile Iron. Custom Stainless Steel 304 or 316.

#### Lubricants

Synthetic Grease, Extreme Pressure EP2 Lithium Grease.



### Selection Guide

#### Selection Notes

- (01) Electric Cylinders and Lifting Systems are for industrial use only, not recommended for transporting personnel.
- (02) Carefully consider electric cylinder ratings before making a selection. Be sure that the dynamic or static load carried or sustained by electric cylinder does not exceed its maximum capacity.
- (03) Make sure that the surface temperature of the housing does not exceed temperature of -15°C to +80°C during operation. Make sure all the rotating parts are completely stopped before proceeding to measure
- (04) The maximum input speed is 1500 rpm as long as the input power dose not exceed the electric cylinder's maximum allowable input power.
- (05) Electric cylinder can not be operated continuously. Duty cycle based on 30 minutes.
  - **Note:** Below duty cycles are based on ambient temperatures 20°C. For ambient temperatures higher than 20 °C, the duty cycle (ED) must be reduced.
  - \* Electric Cylinder with Trapezoidal Screw duty cycle ≤ 20%ED.
  - \* Electric Cylinder with Ball Screw duty cycle ≤ 30%ED.
  - **Note:** For operation longer than that mentioned above or for any continuous operation, the electric cylinders temperature must be monitored and should not exceed 80°C maximum in order to determine its duty cycle.

$$\text{Duty Cycle (\%ED)} = [1 \text{ Duty Cycle} / (1 \text{ Duty Cycle} + 1 \text{ Rest Cycle})] \times 100\%$$

- (06) Be sure not to exceed the maximum input torque for multiple electric cylinders systems by verifying the rated input torque for each jack.
- (07) Be sure that starting torque is 200% or more of required running torque.
- (08) Be sure that ample driving power is available to drive the electric cylinder when using in temperatures below 0°C. Low temperatures decrease the electric cylinder's efficiency due to the increased grease viscosity inside the electric cylinder's gearbox.



Selection Guide

Selection Notes

- (09) Although Electric Cylinder with **Single-start** Trapezoidal Screw has self-locking feature, vibration and shock may affect its efficiency, in which case a brake motor or extra braking device is required. Electric Cylinder with **Double-start** Trapezoidal Screw is considered not self-locking will require a brake or other holding device. Electric Cylinder with Ball Screw can backdrive because of their extremely high efficiencies and require some means of holding the load, such as a brake motor.
- (10) When electric cylinders are working, can not force to stop, may result in the electric cylinders damage or injury personnel.
- (11) When Ball Electric Cylinders are under loads, can not change the motor drive to manual operation. Because the loads will cause the input shaft to rotate very dangerously.
- (12) Mechanical stops (Stop Nuts) are not provided on the lifting screw unless requested. Therefore, it is possible to drive the screw out of the electric cylinder's housing..
- (13) Never approach or touch the rotary parts (input shaft, etc.) or the lifting screw during operation.
- (14) Bellows Boots should be used to protect and keep the lifting cylinder (push rod) clean in dusty or abrasive environments.

Unit Converter

- 1 ft = 304.8 mm
- 1 in = 25.4 mm
- 1 m = 10 dm = 100 cm = 1000 mm
- 1 in-lb = 0.113 Nm
- 1 Nm = 0.737 ft-lb
- 1 ft-lb = 1.356 Nm
- 1 lb = 0.454 kg
- 1 kg = 2.205 lb = 1000 g
- 1 N = 0.1 kg
- 1 t = 1000 kg = 10 kN = 2000 lb
- 1 m/min = 1000 mm/min = 16.7 mm/sec
- 1 in/sec = 25.4 mm/sec
- 1 ft/sec = 304.8 mm/sec
- 1 hp = 0.75 kW
- °C = (°F-32) / 1.8
- °F = °C x 1.8 + 32

Selection Guide

Sample Part Number ( Example ) :

JTE-10T - US - 300 - H - I - C - PP  
 (1) (2) (3) (4) (5) (6) (7)

(1) Models & (4) Gear Ratios

JTE-2.5T H=6:1 L=24:1	JTE-5T H=6:1 L=24:1	JTE-10T H=8:1 L=24:1
JTE-20T H=8:1 L=24:1	H: High ratio L: Slow ratio	

- 1.1) **Model Note 1:**the model indicates the maximum static load of this electric cylinder, but not the maximum dynamic load. The dynamic load depends on the lifting speed, travel length and others working conditions.
- 1.2) **Model Note 2:** The slower the lifting speed, the greater the dynamic load.
- 1.3) **Model Note 3:** In the case of compressed loads and long strokes, please calculate maximum critical buckling force.
- 1.4) **Gear Ratio Note 1:** electric cylinder with gear ratios between 24:1, are self-locking and, in the absence of vibration, will hold loads without backdriving. All other ratios may require a brake to prevent backdriving.
- 1.5) **Gear Ratio Note 2:** Every electric cylinder model with 2 gear ratios as a standard. Custom others gear ratios.

(2) Basic Designs and Configurations

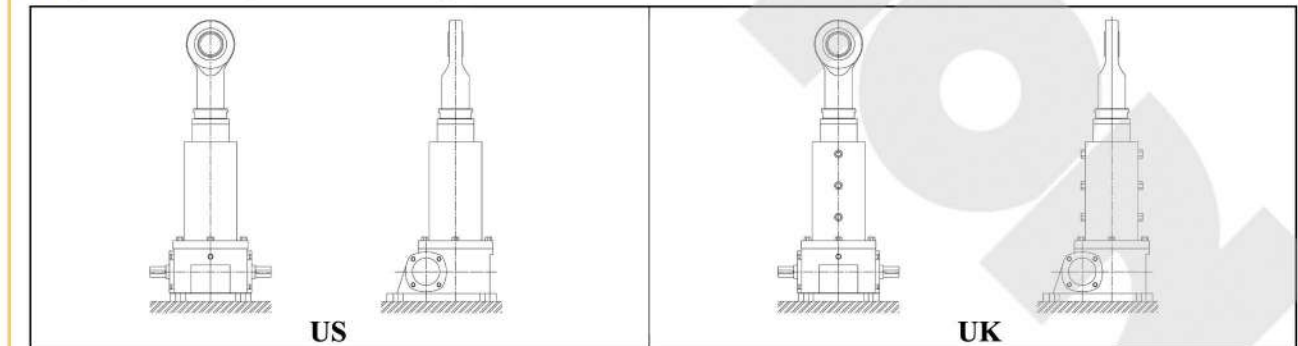

2.1) "US" are **Translating Electric Cylinders**, they are the most commonly specified electric cylinders. All that is required for proper function is to restrain the rotation of the lifting cylinder and apply torque to the input shaft. This is often achieved through the use of guides (guided load) or by attaching a common load across multiple electric cylinder actuator systems. Most applications use this electric cylinder design.



**Selection Guide**

**Sample Part Number**

2.2) "UK" are **Anti-rotation Electric Cylinders**. It is ideal for use in applications where a single electric cylinder must extend to meet and move a load to which it is not attached (unguided). This type electric cylinder is commonly used in single actuator applications where it would not otherwise be possible to restrain the rotation of the lifting cylinder.

- **Note:** Input torque required will increase by approximately 8%

**(3) Stroke and (5) Screw End Fittings**

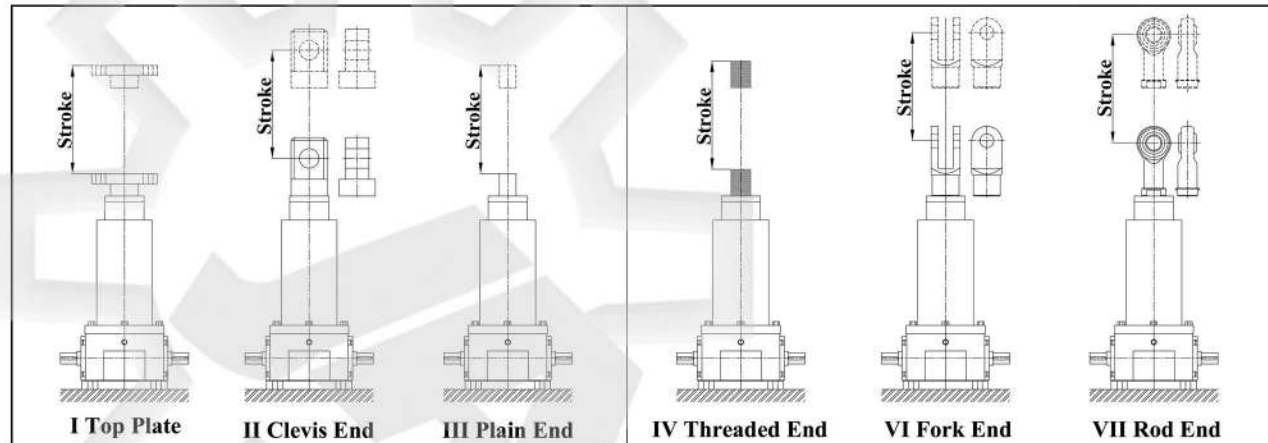

- Stroke is travel expressed in millimeter(mm) or inches and not the actual screw length.
- Standard Lifting Screw End Fittings: Top Plate (I), Clevis End (II), Plain End (III), Threaded End (IV), Forked End (VI) and Rod End (VII). Custom End Fittings are acceptable.

**(6) Input Shafts Codes and Motor Flange Adapters Codes (Top View)**

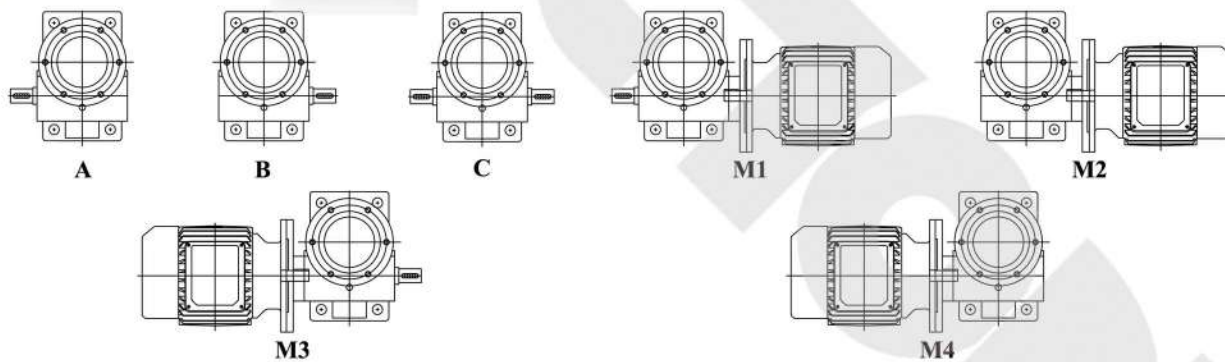

- 6.1) **A:** Single Input, Left Side Shaft.
- 6.2) **B:** Single Input, Right Side Shaft.
- 6.3) **C:** Double Input Shafts
- 6.4) **M1:** Left Side Shaft, Right Side Motor Flange Adapter (Motor Mounts).
- 6.5) **M2:** Right Side Motor Flange Adapter (Motor Mounts).
- 6.6) **M3:** Right Side Shaft, Left Side Motor Flange Adapter (Motor Mounts).
- 6.7) **M4:** Left Side Motor Flange Adapter (Motor Mounts).

- **Note:** Screw Jacks with IEC Motor Flange Adapter as a standard. Custom NEMA Motor Flange Adapter (Stepper Motor), Servo Motor Flange Adapter and Other Non-standard Motor Flange Adapters.

**Selection Guide**

**(7) Accessories**





### Permissible Buckling Load

The primary electric cylinders size selection factor is the buckling resistance of screw shaft, Also know as Euler cures, the graphs (**Euler III: Guided**) below give safety operating state for each size of electric cylinder. Buckling limits are relevant for compressive load only.

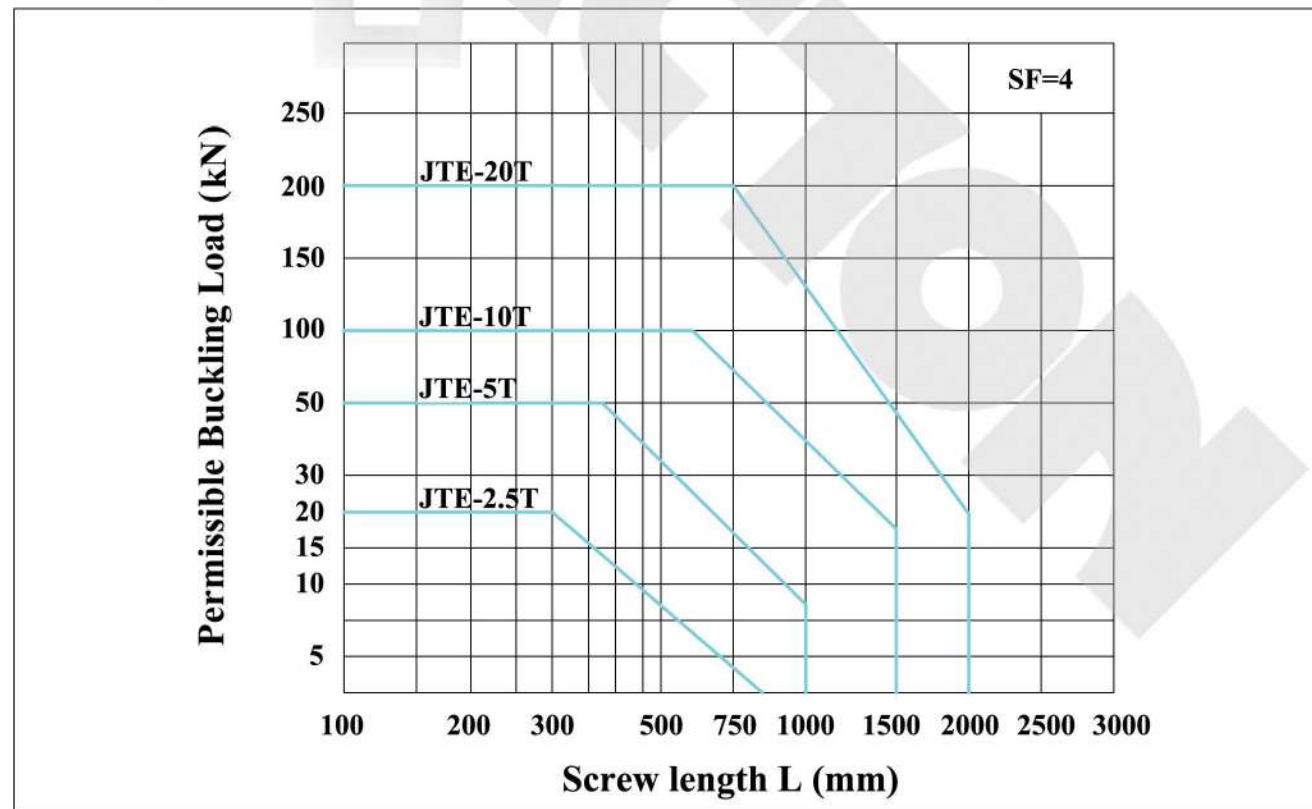
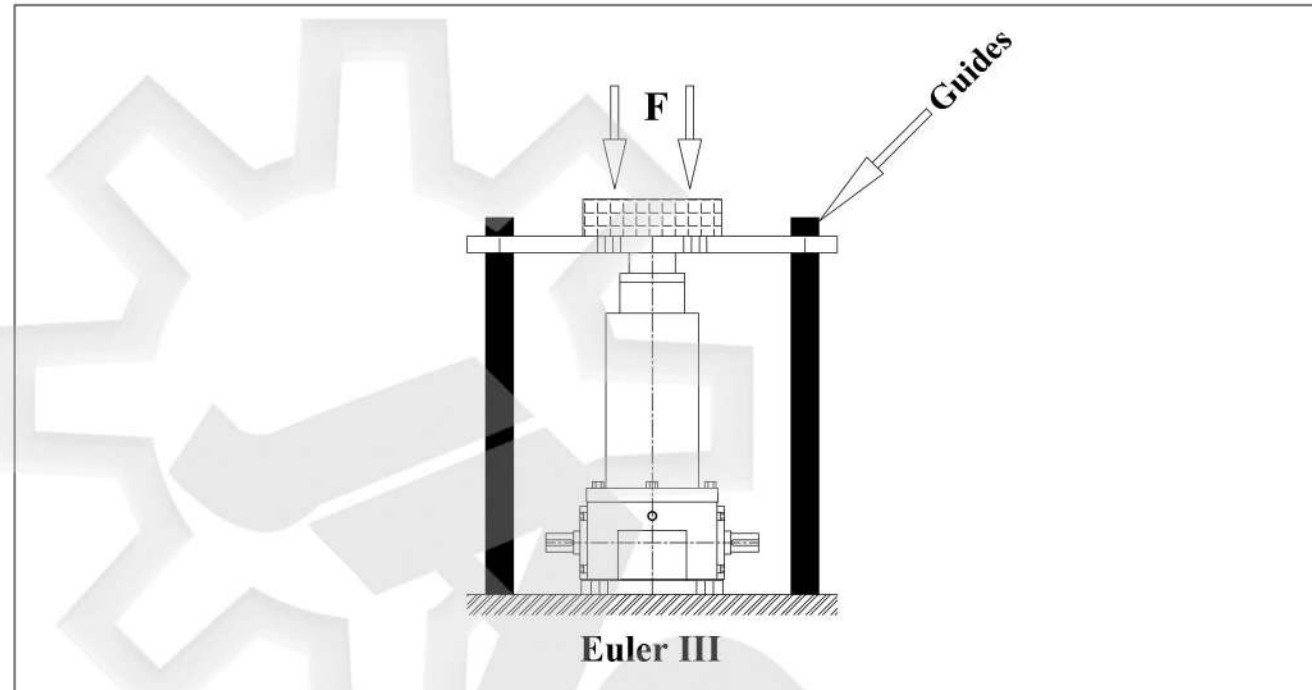

### Specifications

• **Remarks:**

- 1) H: high ratio, L: slow ratio
- 2) Max. allowable power is under the conditions that ambient temperature 20 degree C, duty cycle 20%h and input speed 1500rpm
- 3) Overall efficiency is under grease lubrication.
- 4) Self-locking under static conditions.

Model	JTE-2.5T	JTE-5T	JTE-10T	JTE-20T
Max. Load Capacity (Ton)	2.5	5	10	20
Lift screw sizes (mm)	Tr26 x 5	Tr40 x 8	Tr50 x 10	Tr65 x 12
Root Dia. of screw (mm)	19.7	30.5	38.4	51.3
Gear ratio	H: 6:1	6:1	8:1	8:1
Lift screw travel (mm), per turn of input shaft	H: 0.83	1.33	1.25	1.5
Efficiency %	H: 21	22	22	20
Gear ratio	L: 24:1	24:1	24:1	24:1
Lift screw travel (mm), per turn of input shaft	L: 0.21	0.33	0.42	0.5
Efficiency %	L: 12	14	15	13
Max. allowable power (kw)	H: 1	2	2.8	5
	L: 0.46	0.63	1.4	3.2
No-load torque (Nm)	0.62	1.4	2	3.9
Permissible torque of input shaft (Nm)	49	153.9	292	292
Required torque of input shaft at max. load (Nm)	H: 16.1	48.7	90.7	238.1
	L: 7.4	20	45.3	124
Permissible max. speed (RPM) of input shaft at max. load	H: 600	400	300	200
	L: 600	300	300	250
Lift screw rotational torque (Nm) at max. load	65.1	201.5	503.6	1287.7



Overall Dimensions

JTE-2.5T

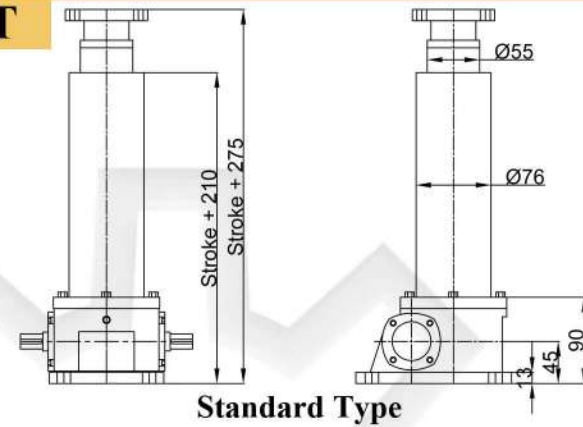

Standard Type

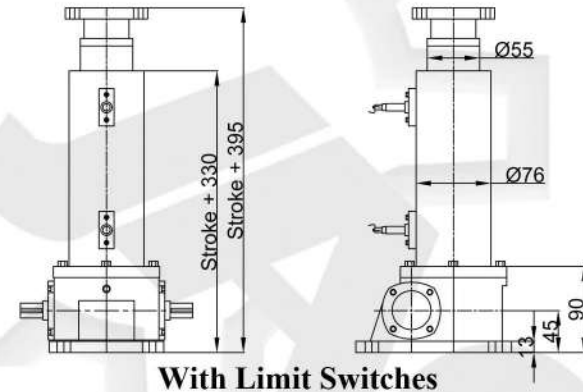

With Limit Switches

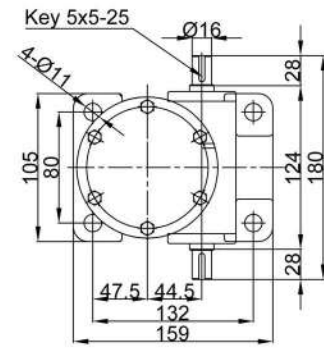

Screw End Types and Dimensions

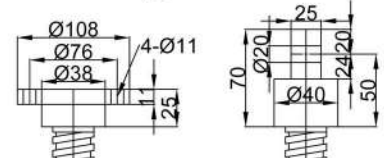

I Top Plate II Clevis End



III Plain End IV Thread End

JTE-5T

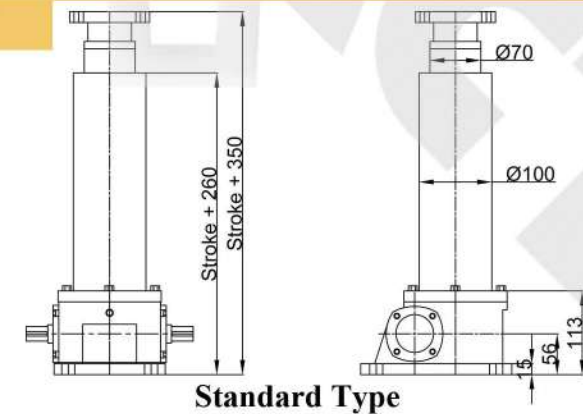

Standard Type

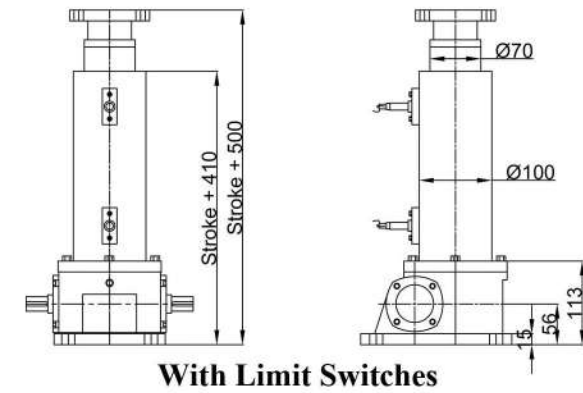

With Limit Switches

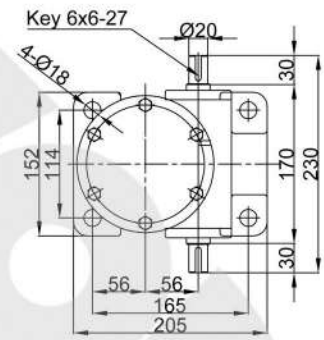

Screw End Types and Dimensions

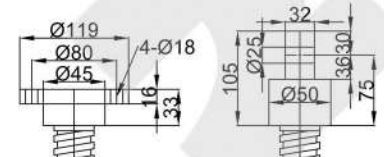

I Top Plate II Clevis End



III Plain End IV Thread End

\*. Dimensions are subject to change without notice

Overall Dimensions

JTE-10T

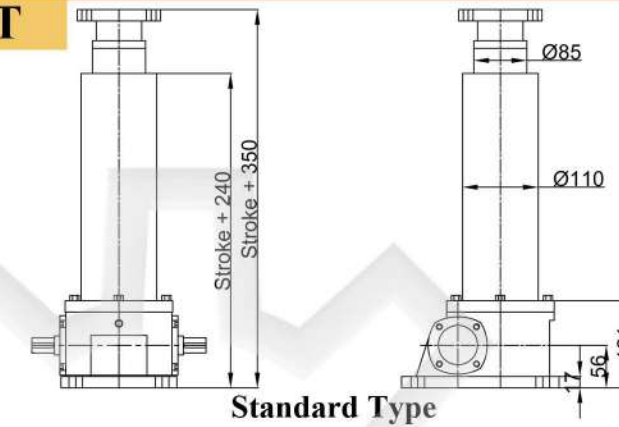

Standard Type

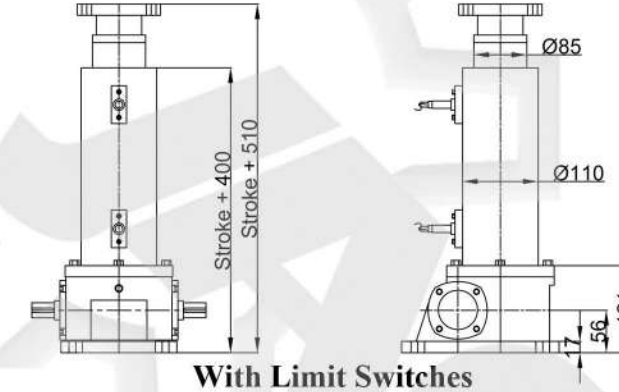

With Limit Switches

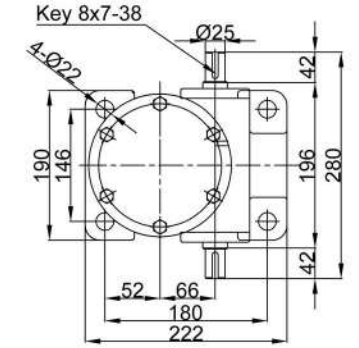

Screw End Types and Dimensions

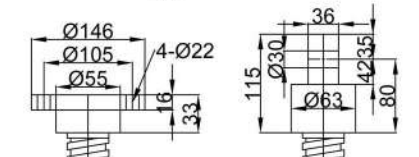

I Top Plate II Clevis End



III Plain End IV Thread End

JTE-20T

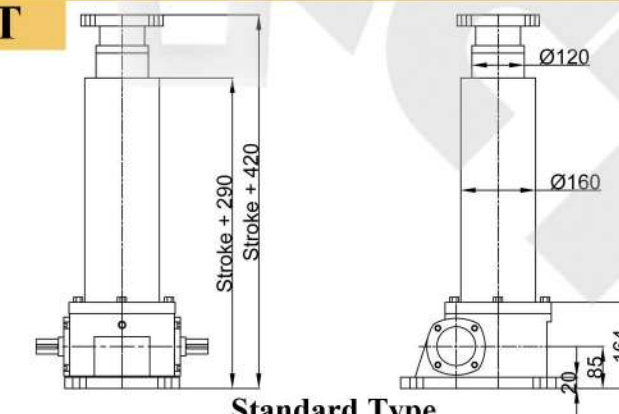

Standard Type

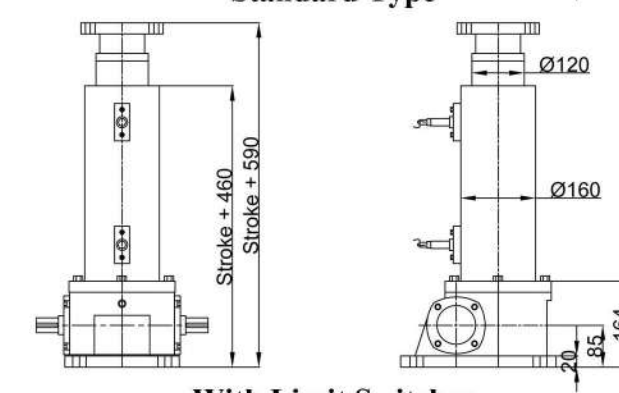

With Limit Switches

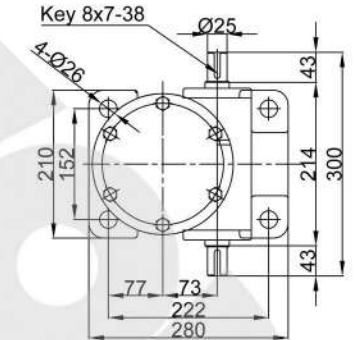

Screw End Types and Dimensions

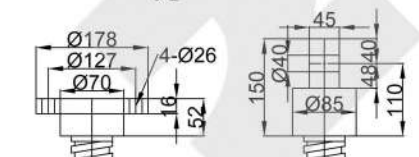

I Top Plate II Clevis End



III Plain End IV Thread End

\*. Dimensions are subject to change without notice



**Other Products**

**Cubic Machine Screw Jack**

- Cubic design permits any mounting position.
- High static loads, best for slow movement and low duty cycles.
- Static load capacities from 2.5 kN to 500 kN as Standard.
- Translating, Anti-rotation (keyed) and Rotating Screw configurations.
- Self locking trapezoidal screw offers maximum stroke of 7500 mm.
- Power source: Manual operation, Motor drive.
- Single jack, or synchronization of multiple jacks arrangement



**Cubic Ball Screw Jack**

- Cubic design permits any mounting position.
- High duty cycle, high precision, high speed, less power and long service life.
- Static load capacities from 10 kN to 350 kN as Standard.
- Translating, Anti-rotation and Rotating Screw configurations.
- Not self-locking ball screw offers maximum stroke of 6000 mm.
- Power source: Brake motor drive. Not suited for manual operation.
- Single jack, or synchronization of multiple jacks arrangements.



**Classic Machine Screw Jack**

- Classic design, no need to attach any construction elements to the housing.
- High static loads, best for slow movement and low duty cycles.
- Static load capacities from 0.5 ton to 100 tons as Standard.
- Translating, Anti-rotation (keyed) and Rotating Screw configurations.
- Self locking trapezoidal screw offers maximum stroke of 7500 mm.
- Power source: Manual operation, Motor drive.
- Single jack, or synchronization of multiple jacks arrangements.



**Stainless Steel Screw Jack**

- Classic design, no need to attach any construction elements to
- Complete Stainless Steel Screw Jack design.
- High static loads, best for slow movement and low duty cycles.
- Static load capacities from 1 ton to 20 tons as Standard.
- Translating, Anti-rotation (keyed) and Rotating Screw configurations.
- Self locking Stainless Steel trapezoidal screw offers maximum stroke of 7500 mm.
- Power source: Manual operation, Motor drive.
- Single jack, or synchronization of multiple jacks arrangements.



**Other Products**

**Classic Ball Screw Jack**

- Classic design, no need to attach any construction elements to the housing.
- High duty cycle, high precision, high speed, less power and long service life.
- Static load capacities from 1 ton to 35 tons as Standard.
- Translating, Anti-rotation and Rotating Screw configurations.
- Not self-locking ball screw offers maximum stroke of 6000 mm.
- Power source: Brake motor drive. Not suited for manual operation
- Single jack, or synchronization of multiple jacks arrangements.



**Bevel Gear Machine Screw Jack**

- High efficiency, high lifting speed, high duty cycle, long lifespan.
- Spiral bevel gear mechanism are used, with 2:1, 2.5:1 and 3:1 ratios.
- Static load capacities from 400 Kg to 3500 Kg as Standard.
- Translating, Anti-rotation (keyed) and Rotating Screw configurations.
- Self locking trapezoidal screw offers maximum stroke of 6000 mm.
- Power source: Manual operation, Motor drive.
- Single jack, or synchronization of multiple jacks arrangement



**Bevel Gear Ball Screw Jack**

- Higher efficiency, higher lifting speed, higher duty cycle, longer lifespan.
- Spiral bevel gear mechanism are used, with 2:1, 2.5:1 and 3:1 ratios.
- Static load capacities from 400 Kg to 3500 Kg as Standard.
- Translating, Anti-rotation and Rotating Screw configurations.
- Not self-locking ball screw offers maximum stroke of 6000 mm.
- Power source: Brake motor drive. Not suited for manual operation.
- Single jack, or synchronization of multiple jacks arrangements.



**Screw Jack Lifting Systems**

- Lifting systems are not limited to the number of screw jacks. Commonly used are 2, 4, 6, 8 jack systems.
- Full synchronization, self-locking, precision positioning, easy installation and operation, maintenance free.
- From a few kilograms to heavy-duty several hundred tons.
- Complete lifting systems with geared motors, shafting and couplings available.
- Power source: Synchronized drive from a single electric motor.
- With Inverter driven motor, soft start and stop, variable lifting speeds are all available.





**Other Products**

**Cubic Bevel Gearbox**

- Modular design spiral bevel gearboxes with cubic housing.
- Ultra Compact Design. All-round tapped holes for universal mounting, 6 possible mounting positions.
- Gear ratios of 1:1, 2:1, 3:1, 4:1 and 5:1 are actual ones.
- Power Ratings up to 156 kW. Torque Ratings up to 1199 N.m.
- Gear transmission average efficiency up to 94%.
- 2-way, 3-way and 4-way Configurations.
- Solid Shaft, Hollow Shaft, and Direct motor mount or via motor flanges.
- High efficiency, high transmission capacity, low backlash, Noiseless operation, low running temperature and long service life.



**Classic Bevel Gearbox**

- Used in pairs case hardened alloy steel spiral bevel gears.
- Gear ratios of 1:1, 1.5:1, 2:1, 2.5:1, 3:1, 4:1 and 5:1 are actual ones.
- Power Ratings up to 335 kW. Torque Ratings up to 5713 N.m.
- Gear transmission average efficiency up to 94%.
- 2-way, 3-way and 4-way Configurations.
- Solid Shaft, Hollow Shaft, and Direct motor mount or via motor flanges.
- Various Shafts Arrangements, Rotation Directions and Mounting Positions available.
- High efficiency, high transmission capacity, low backlash, noiseless operation, low running temperature and long service life.



**Lightweight Bevel Gearbox ( Aluminium Alloy)**

- Quality finished casing by die-casting, in lightweight aluminium alloy.
- Compact design, small-sized, ultra-lightweight, universal mounting.
- Utilizing carburized case-hardened spiral bevel gears
- Gear ratios of 1:1 and 2:1 are actual ones.
- Power Ratings up to 4.94 kW. Torque Ratings up to 40 N.m.
- Gear transmission average efficiency up to 94%
- 2-way and 3-way Configurations.
- High efficiency, low backlash, quiet operation, maintenance free, low running temperature and long service life.



**Other Products**

**Electric Cylinders**

- Be basically screw jacks with travelling nut, but with lifting cylinder design.
- High static loads, best for slow movement and low duty cycles.
- Static load capacities from 2.5 ton to 10 tons as Standard.
- Self-locking, precise positioning, and uniform speed.
- Power source: Manual operation, Motor drive.
- Single unit, or synchronization of multiple units.
- A better choice over hydraulic actuators or pneumatic cylinders with this clean alternative, simpler to install, control, low maintenance and a quieter solution.



**Electric Linear Actuators**

- Parallel or In-Line drive configurations.
- Self-locking ACME screw and nut, driven by an electric motor, through a reduction gearbox.
- Low maintenance due to high-quality grease and enclosed design.
- Load capacities from 100 Kgf to 15 tons as Standard (Parallel)
- Load capacities from 10 Kgf to 1000 Kgf as Standard (In-Line).
- Low noise system, higher dynamic capacity, higher speed capability and longer life.
- Low power consumption and running costs, no oil leaks, contamination or fire risk.
- Easy installation with two trunnion mounting feet, no pipework, powerpack and valves.
- Be a real alternative to pneumatic and hydraulic cylinders.



**Customized and molded products**

