

Ultra High Vacuum Stepper Motors

1.8°, two phase hybrid stepper motors



AML stepper motors are specifically designed for use in UHV environments making them ideally suited for low-speed precision in-vacuum manipulation without the use of particle generating motion feedthroughs.

The considerable reduction in mechanical complexity, absence of metal to metal sliding surfaces and low outgassing characteristics make these motors especially suitable for sensitive handling applications.



The model D motors are two phase hybrid stepper motors, available in a range of standard sizes and torque ratings. Standard motors provide 200 full steps per revolution, are suitable for use below 1×10^{-10} mbar and working temperatures between $-65\text{ }^{\circ}\text{C}$ to $+190\text{ }^{\circ}\text{C}$. Extended low temperature range ($-196\text{ }^{\circ}\text{C}$) versions, radiation hard versions (1×10^6 Gy), shaft modifications and hybrid bearings are all available options.

All motors are designed, cleaned, hand assembled and conditioned to UHV standards in our UK based ISO Class 7 cleanroom.

SPECIFICATIONS

Model	Holding Torque mNm	Detent Torque mNm	Rotor Inertia gcm ²	Max. Axial Force ⁽¹⁾ N	Max. Radial Force ^(1,2) N	Mass g	Current Per Phase A	Phase Resistance at 20 °C Ω	Phase Inductance mH
D28.1	55	6	14	5	9	145	1.0	5.0	2.8
D35.1	75	8	10	9	15	190	1.0	4.7	3.8
D42.1	250	8	25	9	15	350	1.0	5.3	6.6
D42.2	500	14	68	9	15	470	1.0	6.8	10.5
D42.3	550	20	102	9	15	610	1.0	8.5	19.5
D57.1	1,000	30	300	13	40	885	1.0	10.5	27.0

Vacuum environment	1×10^{-10} mbar
Operating temperature	$-65\text{ }^{\circ}\text{C}$ to $+190\text{ }^{\circ}\text{C}$
Temperature sensor	Type 'K' thermocouple standard or PT100 optional
Bakeout temperature	200 °C
Step angle	1.8°
Step angle tolerance	±5%
Lead length	1.5m

(1) Reduced by 40% for motors with option H/C.

(2) 20 mm from the flange.

CHARACTERISTICS

The performance shown on these graphs was obtained using an SMD3 drive configured for 256 step division up to a step frequency of 1000 Hz, and full step mode thereafter. Source voltage is 67 V.

The SMD3 stepper motor drive is a single-axis bipolar stepper motor drive, intended for use with AML's range of vacuum compatible stepper motors (VCSMs), with maximum performance and minimal heat.

Different drives will produce different speed / torque curves. Drives producing phase currents greater than 1 A RMS may damage the insulation. Reducing the drive voltage may impair high speed performance. Use of the embedded temperature sensor is essential for motor protection.

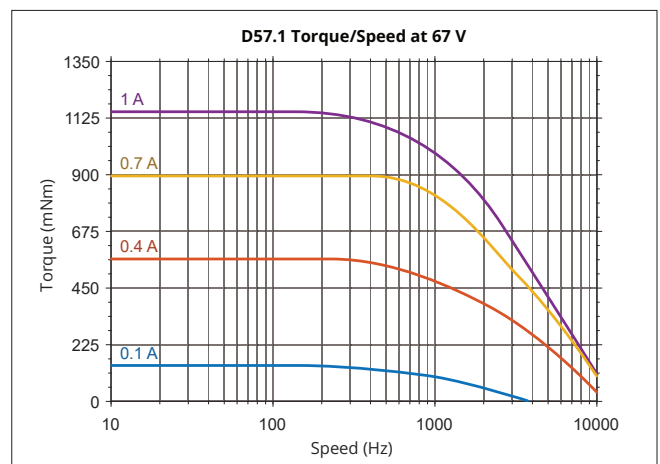
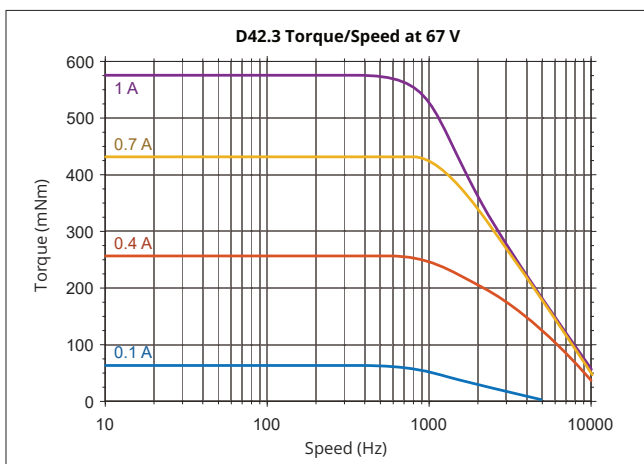
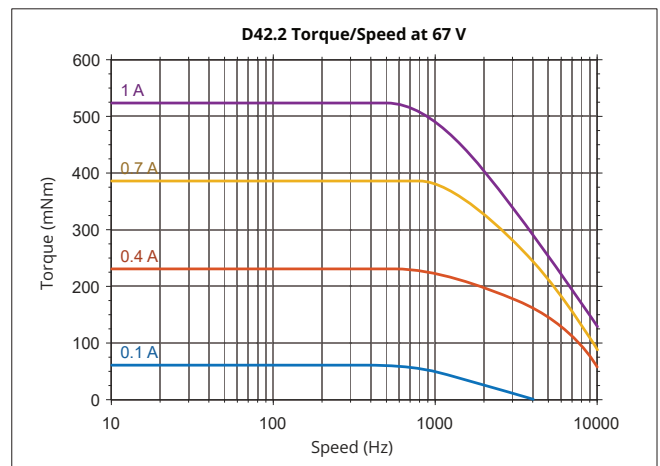
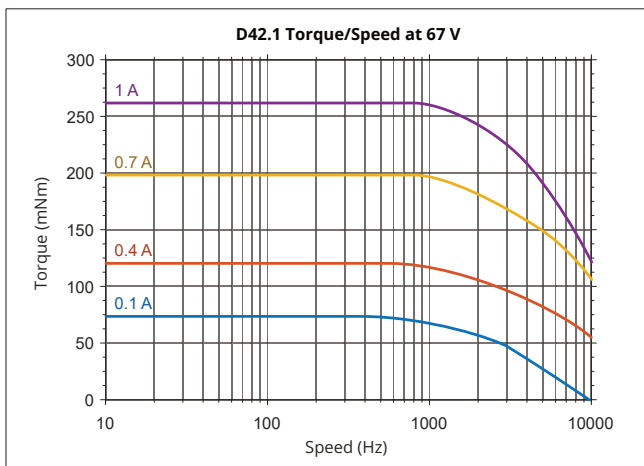
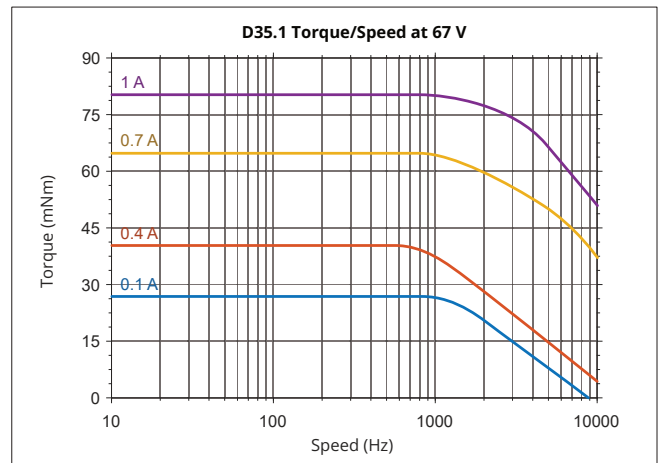
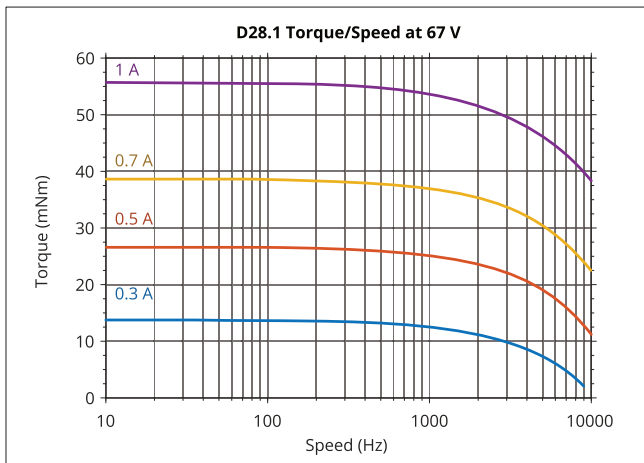

CHARACTERISTICS CONT.

The temperature performance shown on this graph demonstrates the importance of optimised duty cycles and drive current for stepper motors in a vacuum environment. This data was obtained using an SMD3 drive operating at 1000 Hz in full step mode with a source voltage of 67 V.

The absence of convection in a vacuum causes motors to heat up rapidly. For this reason, wherever possible applications should be designed so that the load may be held in a position by the detent torque of the motor, so that power may be removed between periods of motion; to minimise temperature rise and outgassing.

Use of the embedded temperature sensor is essential for motor protection. Irreversible damage of the motor windings will occur if the temperature exceeds the stated maximum operating temperature.

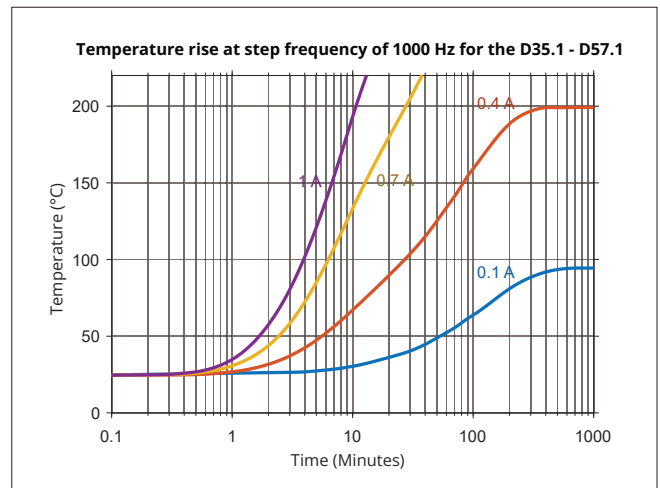
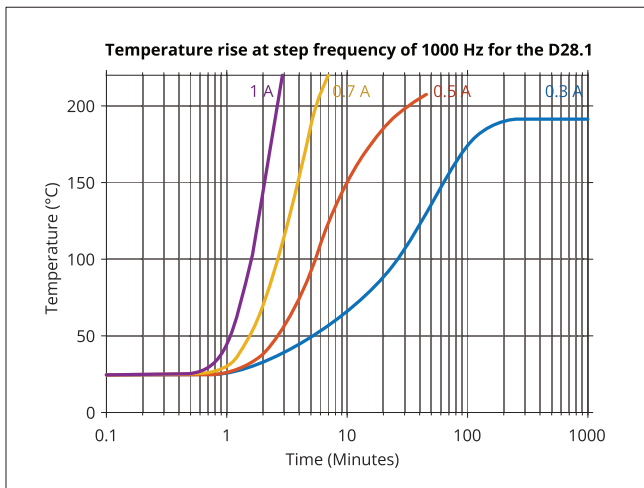

ELECTRICAL CONNECTION

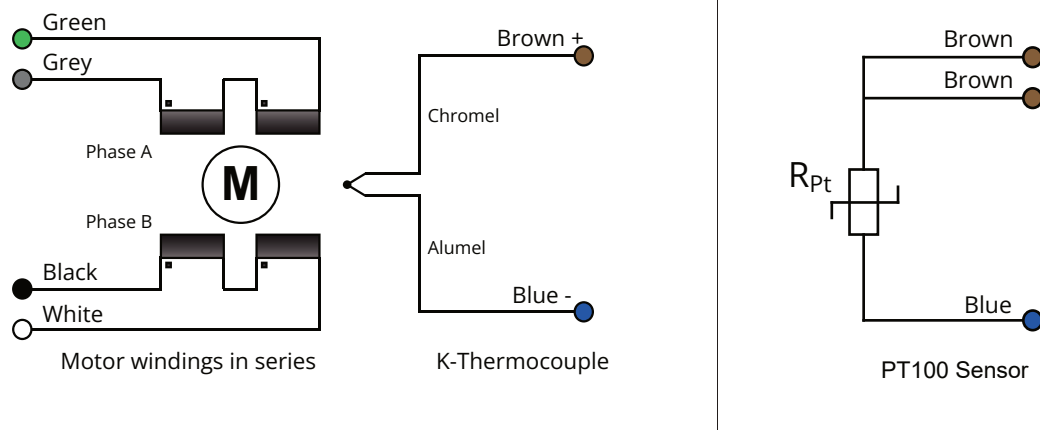

OPTIONAL CONNECTORS

AML offers a range of UHV compatible connectors, including MLF18 and D-sub types, which can be fitted to any AML stepper motor during manufacture for the price of the connector.



AML STEPPER MOTOR DRIVES

AML offers two stepper motor drives. The SMD3 and SMD4 stepper motor drives are single-axis bipolar stepper motor drives both engineered to drive vacuum-compatible stepper motors with maximum performance and minimal heat. They are optimised for use with AML UHV-compatible motors.

SMD3

Single-axis bipolar stepper motor drive.
Compact, cost effective option.



SMD4

All SMD3 features + advanced connectivity (Ethernet, RS232 or 485) and optional encoder module.



AML manufacture a range of airside cables to connect the SMD3 and SMD4 to your feedthrough of choice.

The AML Device Control Software is a powerful software package supplied with the SMD3 and SMD4 that enables you to control and configure multiple AML devices simultaneously in a single user-friendly graphical interface. Full details can be accessed on the SMD3 and SMD4 user manuals.

DIMENSIONS

D28.1

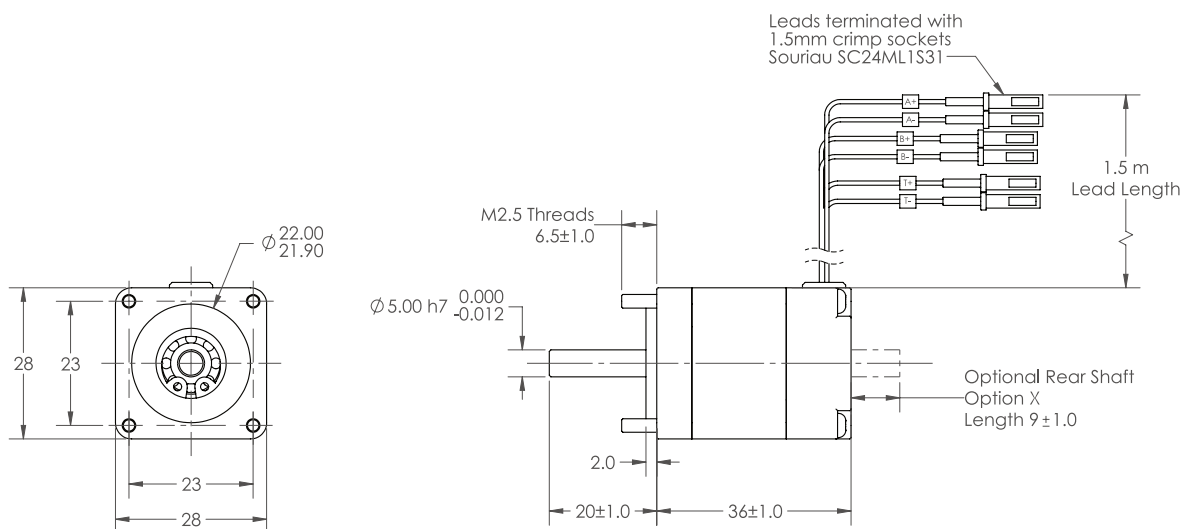

DIMENSIONS CONT.

D35.1

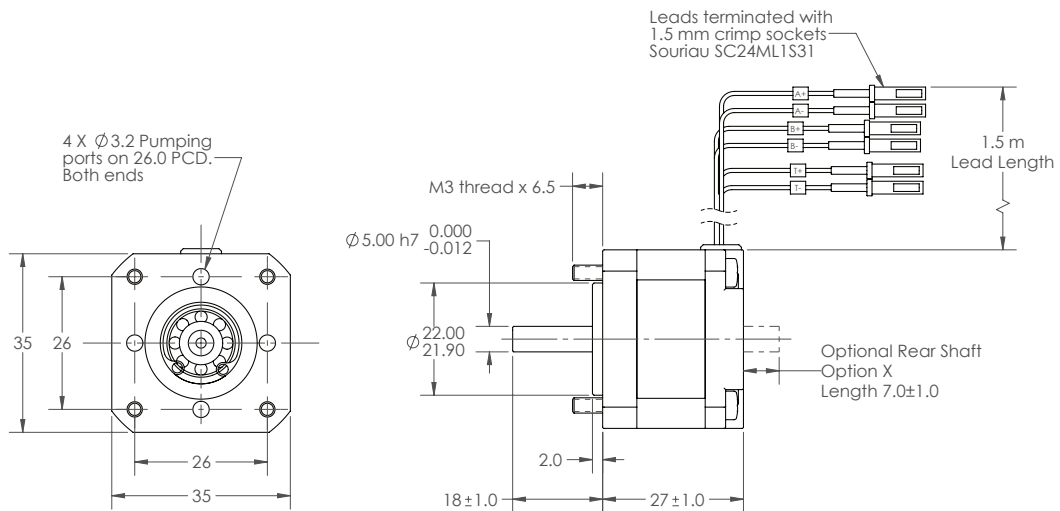

D42.X

Motor Part No.	L	RS
D42.1	33	10.5
D42.2	47	24.0
D42.3	60	24.0

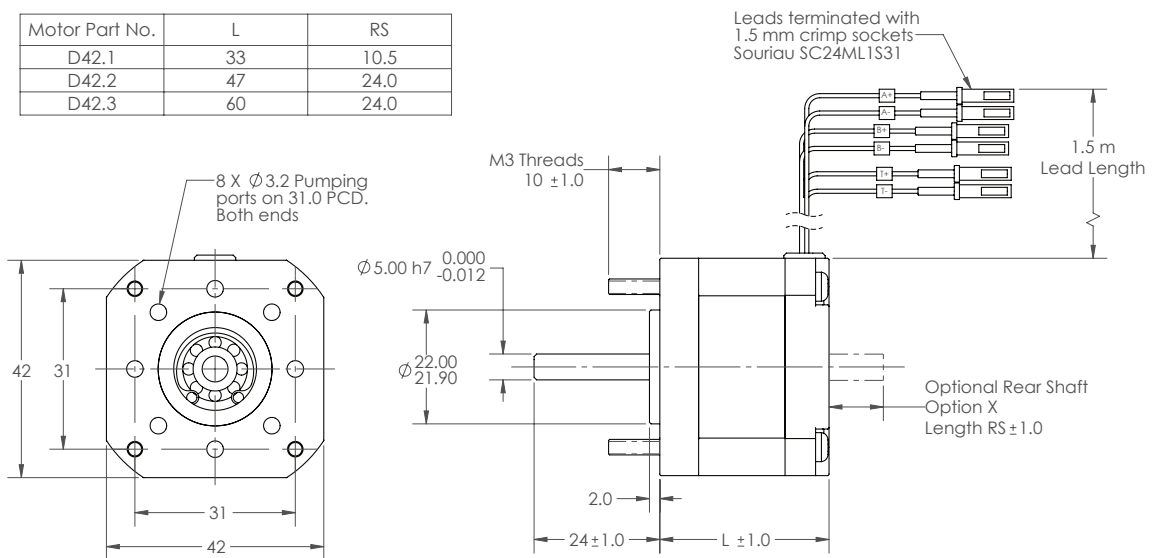

D57.1

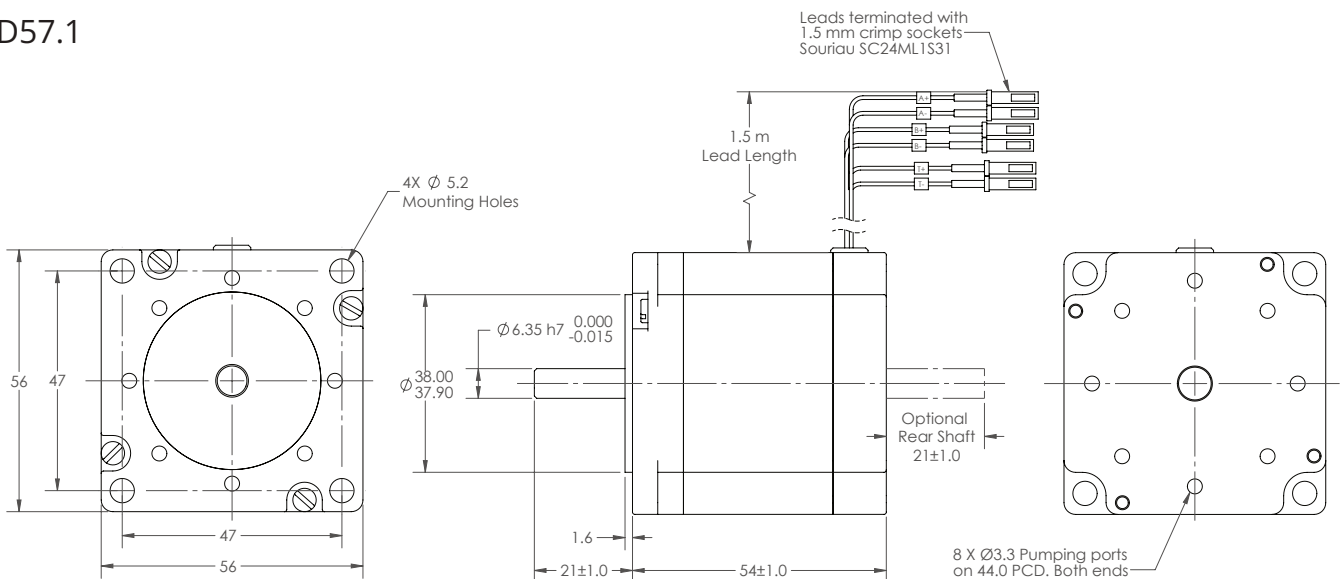

CUSTOMISATIONS

Further to our standard range of options listed below, we can also customise other aspects of our motors to meet your application needs. Our modification capabilities include, but are not limited to:

- Custom front/rear end caps
- Rear shaft
- Custom leadouts (length/connectors)
- Bearing design and lubrication

Contact our sales team to discuss how we can design a solution suitable for your application requirements.

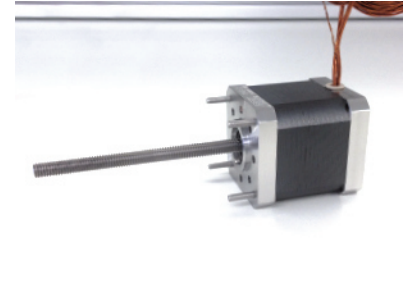
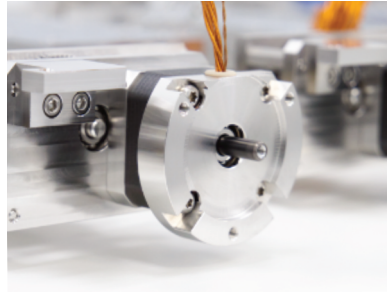

ORDERING INFORMATION

Bearings

Standard motors are fitted with open stainless steel bearings lubricated with NyeTorr® 6300 ultra low outgassing UHV grease.

! AML always recommends NyeTorr® UHV grease lubricated bearings if your application can accommodate it.

For low duty applications where UHV grease is not permitted, specify option 'H' hybrid bearings. These have silicon nitride ceramic balls, dry lubricated with Tungsten disulfide.

! Please note that the life expectancy of dry lubricated bearings may, depending on the application, be significantly shorter than bearings lubricated with NyeTorr® UHV grease.

Options

- H** Hybrid ceramic bearings (dry lubricated)
- R** Gamma radiation hardened to 1×10^6 Gy (dry lubricated bearings)
- X** Shaft modification. Please provide a sketch of your requirement
- C** Cryogenic. Extended operating temperature range. -196 °C to $+190$ °C (dry lubricated bearings)
- P** PT100 temperature sensor in lieu of thermocouple

Order Code	
D28.1	55 mNm UHV Stepper Motor
D35.1	75 mNm UHV Stepper Motor
D42.1	250 mNm UHV Stepper Motor
D42.2	500 mNm UHV Stepper Motor
D42.3	550 mNm UHV Stepper Motor
D57.1	1,000 mNm UHV Stepper Motor

Related Products	
SMD3	Stepper motor drive
SMD4	Stepper motor drive with advanced connectivity
MLF18VCF	In-vacuum bakeable female connector, 18-way
VCxxDF	D-sub 9/15-way female UHV connector



Distributors for Australia & New Zealand
MOTION TECHNOLOGIES PTY LIMITED



24/22-30 Northumberland Road
 Caringbah NSW 2229 Australia
 Phone: (02) 9524 4782

sales@motiontech.com.au
 www.motiontech.com.au

28/11/2025

AML pursues a policy of continuous improvement and reserves the right to make detail changes to specifications without consultation. E and OE.