

# VSM17-Z Translation Stage

Ultra High Vacuum Modular Translation Stages

AML ultra high vacuum compatible vertical linear translation stages for z-axis translation of loads up to 30 kg.

They can be used standalone or as part of a complex motion system, as they are compatible with the range of VSM17 modular stages. Specifically designed for Z-axis translation, the sample table is always above the mechanism across the stage's full range of travel.

They are manufactured with UHV compatible material and construction methods and utilise AML UHV stepper motors.



## FEATURES

- Standard travels from 50 to 70 mm
- 1  $\mu\text{m}$  resolution
- 0.26  $\mu\text{m}$  repeatability
- Maximum speed of 5 mm/sec
- Suitable for use to  $1 \times 10^{-10}$  mBar
- Bakeable to 200 °C
- 30 kg centred load capacity
- Features AML D35.1 stepper motor
- Can optionally be fitted with limit switches or an optical encoder
- Radiation resistant and dry lubricated versions available
- Designed for Z-axis translation
- Compatible with all VSM17 modular stages
- May be customised for specific requirements

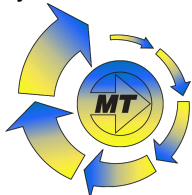

[www.motiontech.com.au](http://www.motiontech.com.au)

## SPECIFICATIONS

Specification	VSM17-Z-050	VSM17-Z-070
Travel	50	70
Resolution	1 µm	
Maximum Speed	5 mm/s	
Repeatability	0.26 µm	
Centred Load Capacity	30 kg	
Maximum Load Moment	80 Nm	42 Nm
Roll, Pitch and Yaw (Unloaded)	±78 µrad	±67 µrad
Roll, Pitch and Yaw Compliance	±54 µrad/Nm	±66 µrad/Nm
Straightness of Travel	3 µm/100 mm	
Stepper Motor	AML D35.1	
Vacuum Environment	<1 x 10 <sup>-10</sup> mBar	
Maximum Temperature	200 °C (reduces to 120 °C when an optional encoder is fitted)	
Mass Including Motor	2.1 kg	2.6 kg

Optional Encoder Specification	ER (Incremental Encoder)	EA (Absolute Encoder)
Readhead	Renishaw TONiC™ T1630-15M	Renishaw RESOLUTE™ RL26BVE050D15V
Scale	RKLC20 20 µm pitch	RELA30 30 µm pitch
Interface Module	T10040A10A 40x interpolation factor	None
Electrical Interface	Square wave differential line driver to EIA RS422A	BiSS-C (unidirectional) 26 bit
Resolution	500 nm	50 nm

## NOTES

**BACKLASH:** Backlash in the gearbox of the VSM17-Z is controlled by special gearing and is negligible. Backlash between the nut and leadscrew is controlled by gravity.

**LUBRICATION:** Running surfaces are dissimilar materials or dry lubricated with molybdenum disulfide. Leadscrews are lubricated with Nyetorr® 6300 UHV grease. Dry lubrication can be specified.

**VERNIER STOP:** These stages may be driven to the vernier stops at the limits of their travel and stalled without damage.

**STACKED MECHANISMS:** For 3-axis motion mount the stage moving the load vertically on top of the others to avoid adding their weight to its load.

## OPTIONS

**LS** Adds 2x limit switches to the stage.

**ER** Adds a Renishaw TONiC™ UHV incremental encoder on the stage.  
Renishaw readhead part number: T1630-15M.

**EA** Adds a Renishaw RESOLUTE™ UHV absolute encoder.  
Renishaw readhead part number: RL26BVE050D15V.

**R** Adapts the stage so that it is radiation hardened, making it compatible with a total dose of 1E6 Gy of gamma radiation.

**DIMENSIONS**

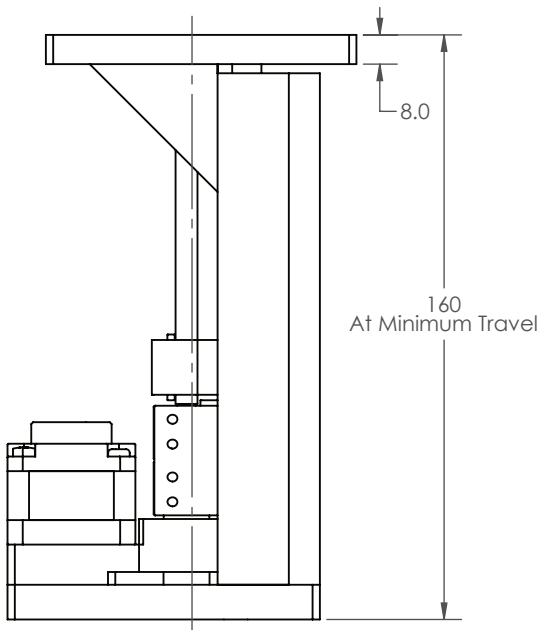
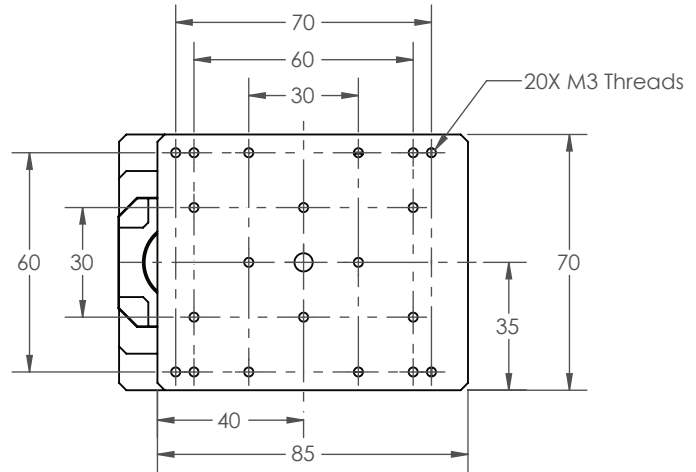

**VSM17-Z-070**

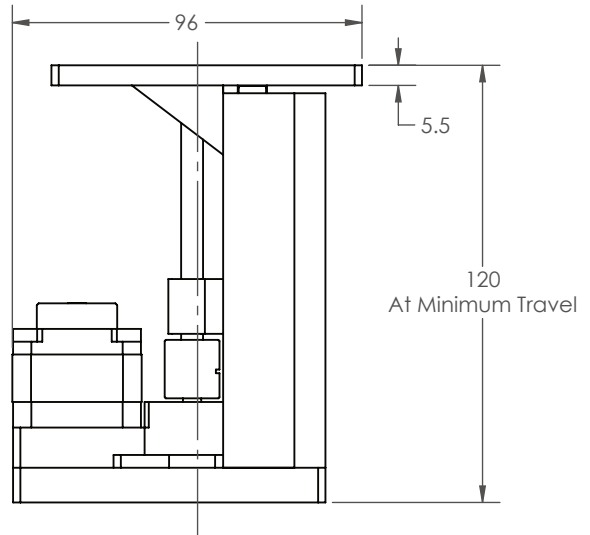

**VSM17-Z-050**

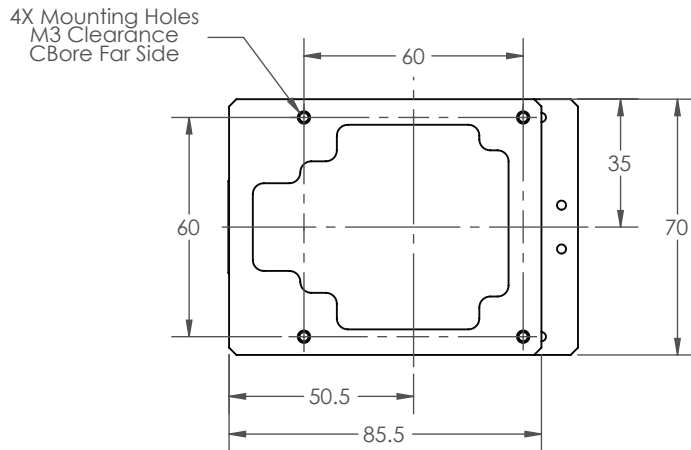

## RELATED PRODUCTS

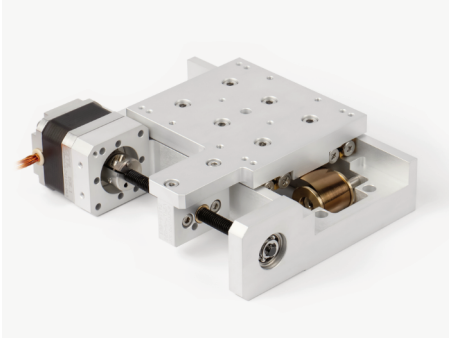

VSM17-X

High Performance, Modular UHV Compatible Stage.

Linear translation stage suitable for use in UHV. Can support loads of up to several kilograms and travel from 50 to 200 mm. 5  $\mu\text{m}$  resolution allows for precise in-vacuum motion.

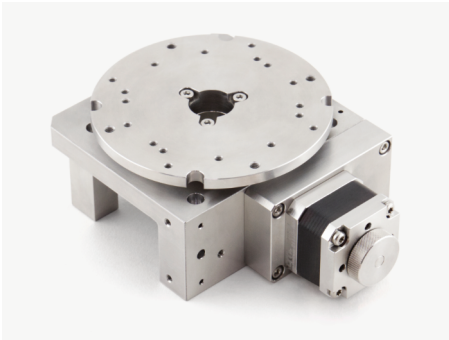

VSM17-R

High Performance, Modular UHV Rotation Stage.

Rotation stage suitable for use in UHV. Can support loads of up to 100 kilograms. Resolutions from 0.1° to 0.005° with 360° of continuous rotation.

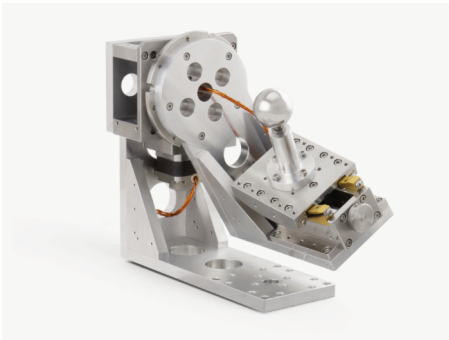

VSM17-G

High Performance, Modular UHV Goniometer Stage.

Goniometer stage suitable for use in UHV. It is possible to build a Euler goniometer with a common centre of rotation.

## ORDERING INFORMATION

Order Code	
VSM17-Z-xxx	1 $\mu\text{m}$ resolution (xxx=travel in mm)
VSM17-Z-xxx-LS	1 $\mu\text{m}$ resolution with 2 x limit switches
VSM17-Z-xxx-EA	1 $\mu\text{m}$ resolution with encoder (absolute)
VSM17-Z-xxx-ER	1 $\mu\text{m}$ resolution with encoder (incremental)
VSM17-Z-xxx-R	1 $\mu\text{m}$ resolution, radiation resistant

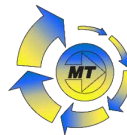

Distributors for Australia & New Zealand

**MOTION TECHNOLOGIES PTY LIMITED**

24/22-30 Northumberland Road  
Caringbah NSW 2229 Australia  
Phone: (02) 9524 4782

sales@motiontech.com.au  
www.motiontech.com.au

28/11/2025



AML pursues a policy of continuous improvement and reserves the right to make detail changes to specifications without consultation. E and OE.