

BONENG

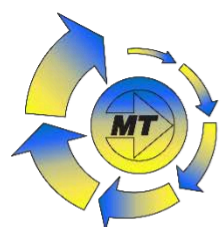

Distributors for Australia & New Zealand
MOTION TECHNOLOGIES PTY LIMITED



24/22-30 Northumberland Road
Caringbah NSW 2229 Australia
Phone: (02) 9524 4782

sales@motiontech.com.au
www.motiontech.com.au

19/01/2026

T系列螺旋锥齿轮转向箱

T Series Spiral Bevel Gear Units

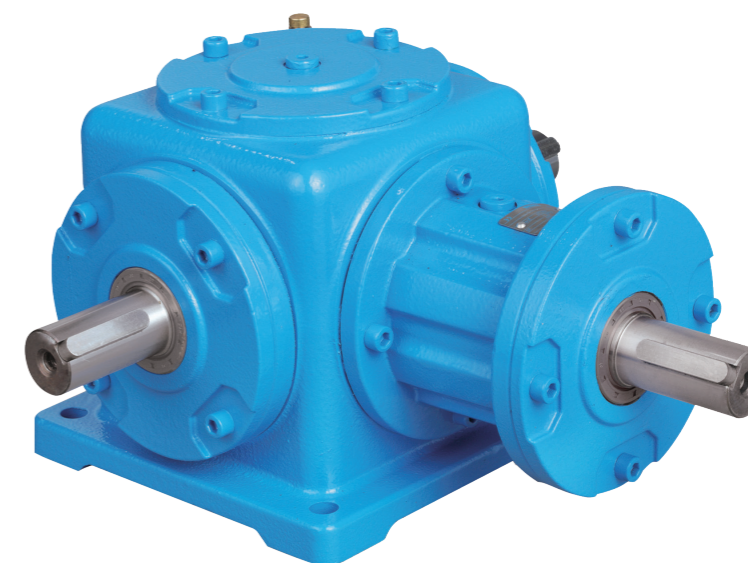

T系列螺旋锥
齿轮转向箱

T Series Spiral
Bevel Gear Units

Modified date 08/2023
Selection Sample C05.0010

BONENG

Boneng Transmission

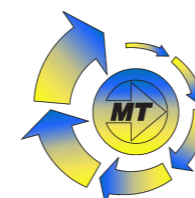

www.motiontech.com.au

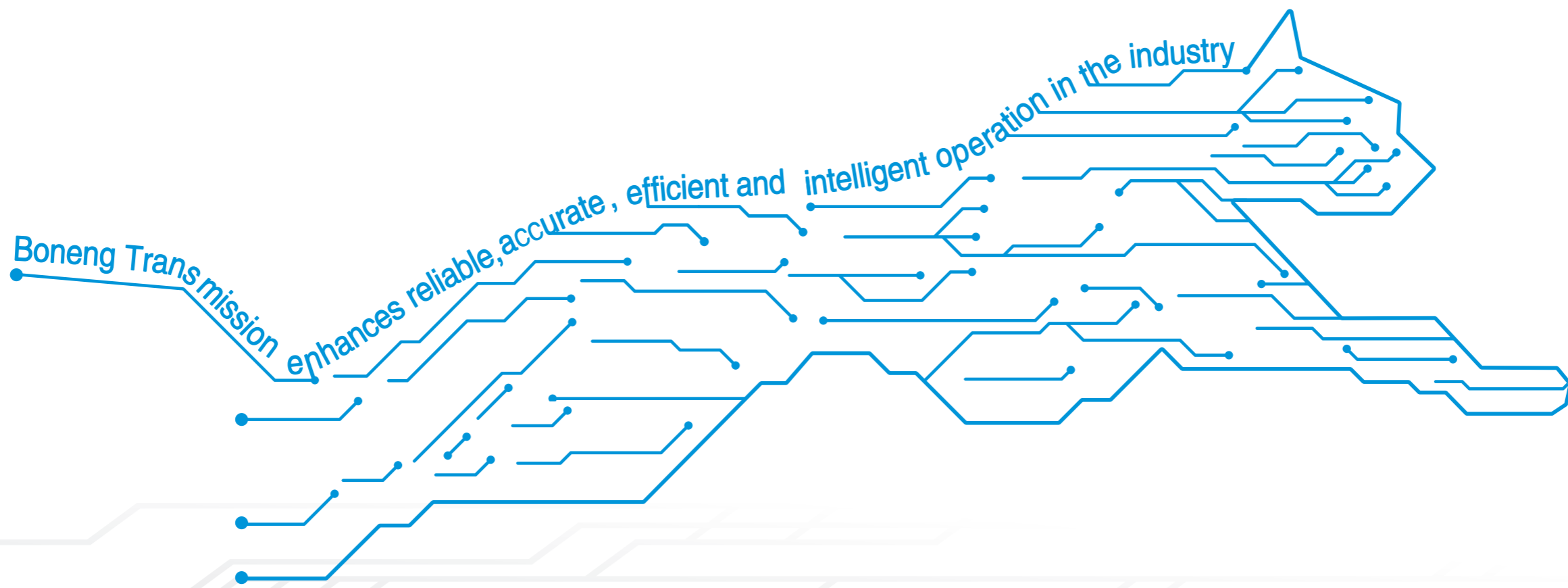

控制器/驱动器/马达/
齿轮马达/齿轮箱

Controller/ Drive/ Motor/
Gearmotor/ Gearbox

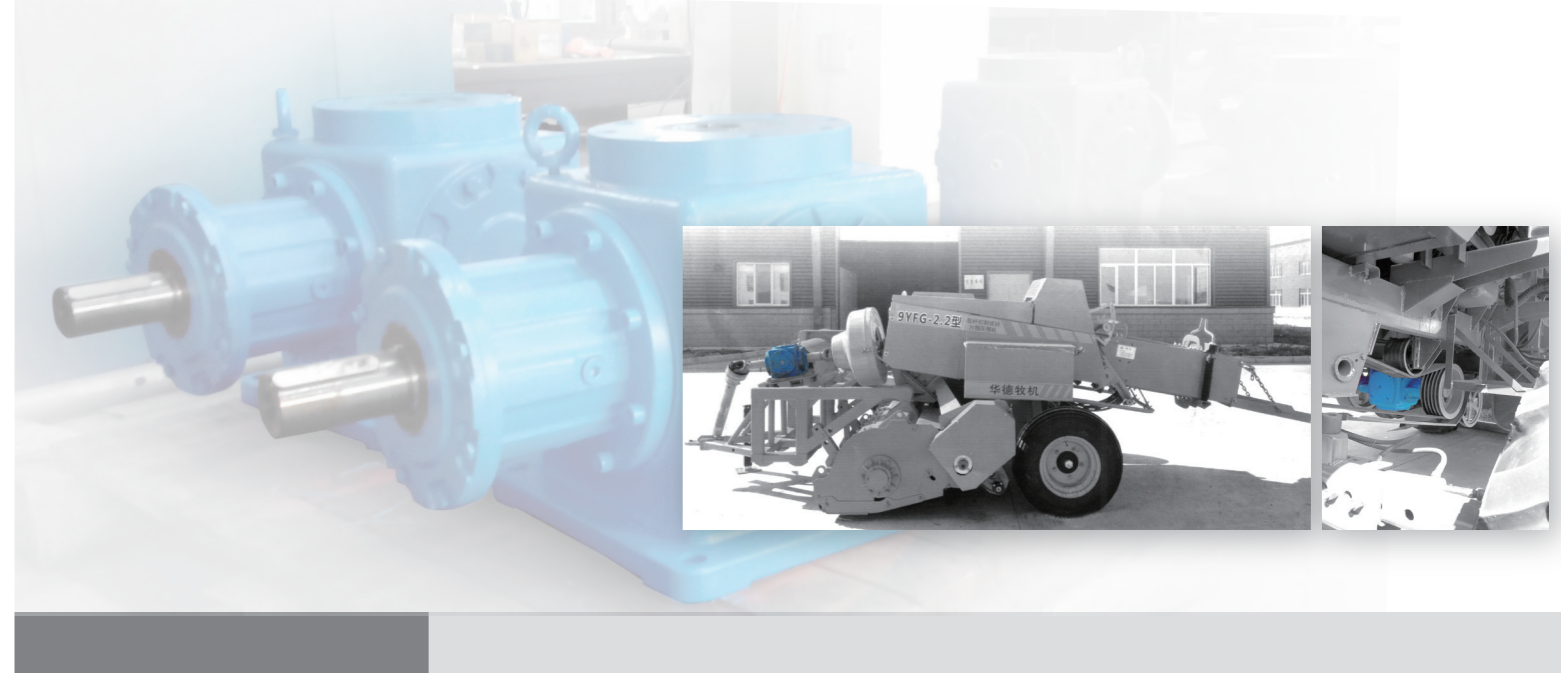

T系列螺旋锥齿轮转向箱

- ◆ 标准化,多品种,速比1:1、1.5:1、2:1、3:1全部为实际传动比。
- ◆ 可采用任意安装位置
- ◆ 可提供双输入轴形式
- ◆ 可实现多出轴
- ◆ 当速比不为1:1时,横轴输入、纵轴输出为减速,纵轴输入、横轴输出为增速
螺旋锥齿轮可以正反运转,低速或高速传
- ◆ 动平稳,而且噪声低,振动小,承受力大

在农业、食品、化工、环保、林木、造纸、建筑建材等等各个领域;
博能传动公司总部和各大区域的技术专家以及各区域办事处的应用工程师、售后服务技师竭诚为您提供全面的技术咨询和完善的服

Spiral Bevel Gear Units

- ◆ The exact ratio of T series can be 1:1,1.5:2.1,2:1,3:1
- ◆ Mounting position can be selected by clients
- ◆ Double input shaft
- ◆ Multiple output shaft
- ◆ T series can be used for speed increase and decrease when the ratio is not 1.
- ◆ The spiral bevel gear can be forward reverse,-transmission stability,quiet running,small vibration and large bearing capacity.

In all industry,all technology team and sales of BONENG will offer best technical solution and best service to you.

注意事项!必须严格遵守以下各项!

- ◆ 样本中的结构示意图、外形图及其他附图只属范例,无严格比例要求。(未注尺寸单位均为mm)。
- ◆ 所注重量仅为平均值,并不具有约束力。
- ◆ 为防止意外事故发生,所有旋转部件均按照使用者所在国家和地区的安全规范由购置方加罩保护。
- ◆ 试车之前必须认真阅读使用说明书。
- ◆ 齿轮箱在供货时已处于准运行状态,运行前需加注润滑油。
- ◆ 本样本中注油量只作为参考值,实际注油量应以油镜上的标记为准。
- ◆ 润滑油粘度应按齿轮箱使用工况及使用环境温度选取。
- ◆ 只能采用国际知名品牌的润滑油。

产品功能标识



油 镜



通气帽



进油孔



放油孔

Note: You must conform to the following instructions

- ◆ The structure scheme,appearance diagram and other attached diagrams in sample are examples,there is no strict pproportion requirement.(the unmarked dimension units are mm). We can only refer to the marked weight in the manual.
- ◆ To prevent accidents,all the rotation parts should be added with protective covers according to local safety regulations and laws.
- ◆ Berore testing,users should read instruction manual carefully. Gear unit has been tested before delivered,users should add lubrication oil before running.
- ◆ We can only refer to the marked oil in the manual.Actual oil filling level should be the same with the mark on oil immersion lens.
- ◆ Lubrication oil viscosity should be selected according to working conditions and the temperature of local environment. Users can only use high quality lubrication oil.

Product Function Mark



Oil immersion lens



Breather



Oil filler



Oil drainage

目录

01.结构示意图	01
02.型号表示方法	01
03.旋转方向	02
04.输入轴与转速的关系	02
05.应用实例	02
06.被驱动设备系数	03
07.选型举例	03
08.轴径向力Fr表	04
09.传动能力表	05
10.轴配置及轴旋转方向的关系、安装方位及尺寸图表	07
11.附件	09
12.应用举例	09
13.轴端中心孔	10
14.平键与键槽的尺寸	11

CONTENTS

01.Sectional Drawings ..	01
02.Type Designation	01
03.Direction of Rotation	02
04.Relation between input shaft and speed	02
05.Application Examples	02
06.Drven Machine Factor	03
07.Examples of Type Swlection	03
08.Radial Force on Shafts(Fr)	04
09.Transmission Capacity	05
10.Relation between Shaft Arrangement and Direction of Rottion;Mounting Positions and Dimensions	07
11.Accessories	09
12.Application Exmaples	09
13.Screw hole in shaft end	10
14.Parallel keys and keyway	11

1 结构示意图

1 Sectional Drawings:

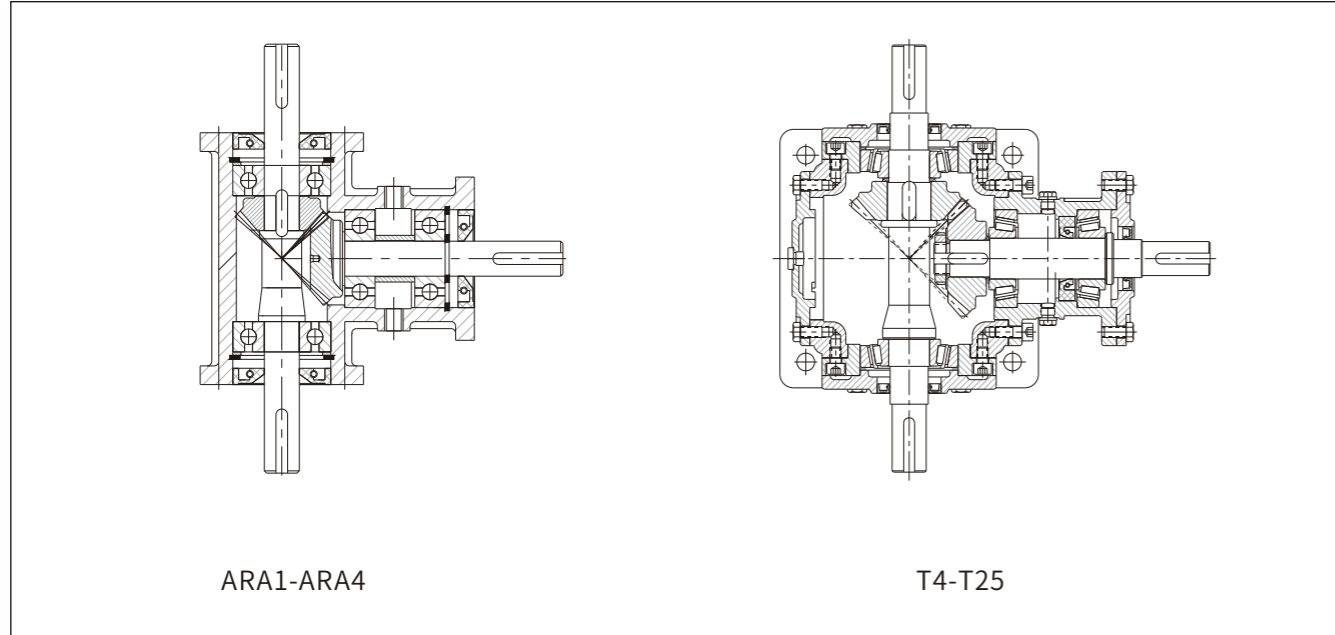

2 型号表示方法

2 Type Designation:

2.1 T系列

2.1 T Series:

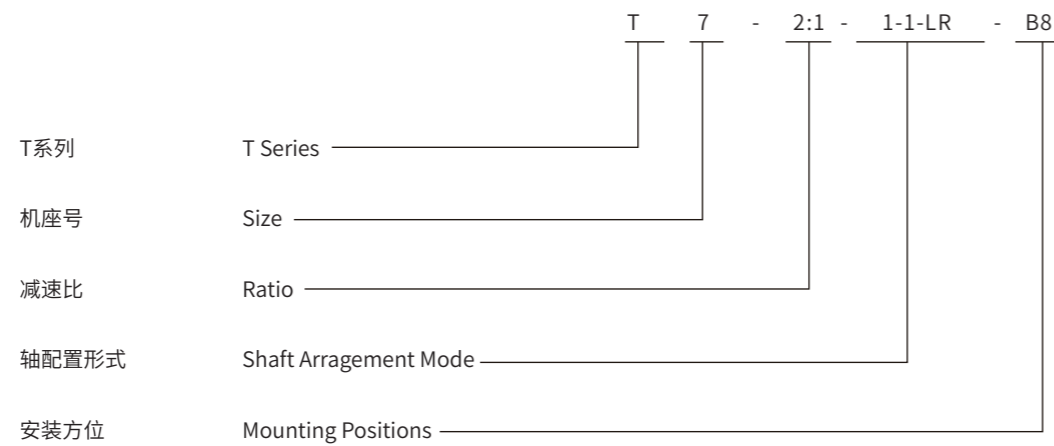

2.2 ARA系列

2.1 ARA Series:

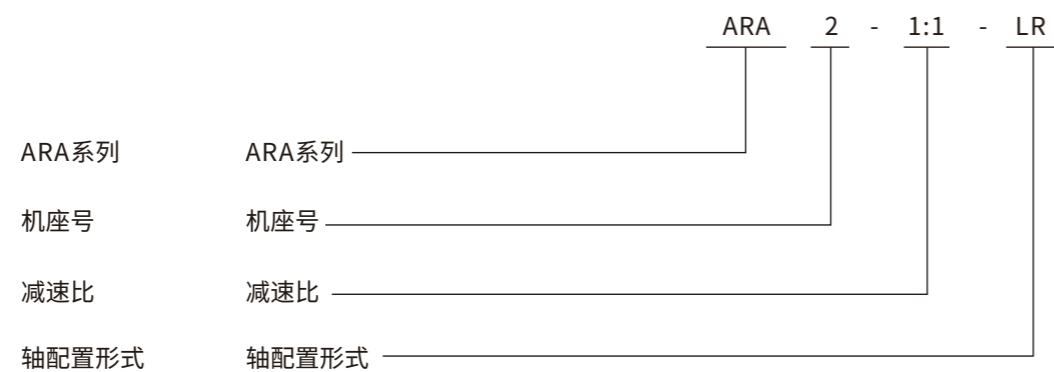

3 旋转方向

3 Direction of Rotation

1横轴 One X-shaft		2横轴 Two X-shafts	
2轴 Two extended shafts	3轴 Three extended shafts	3轴 Three extended shafts	4轴 Four extended shafts
纵轴 Y-shaft	纵轴 Y-shaft	横轴 X-shaft	横轴 X-shaft
横轴 X-shaft	横轴 X-shaft	纵轴 Y-shaft	纵轴 Y-shaft
		横轴 X-shaft	横轴 X-shaft

说明:当输入轴旋转方向改变,输出轴相应改变。

Note: Direction of rotation of the output shaft varies with that of the input shaft.

4 输入轴与转速的关系

4 Relation between input shaft and speed

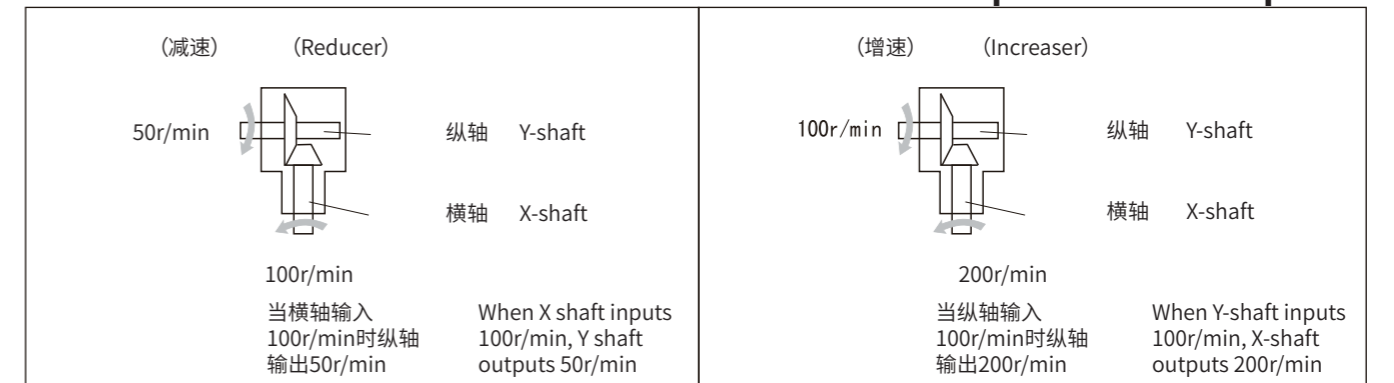

5 应用实例

5 Application Examples

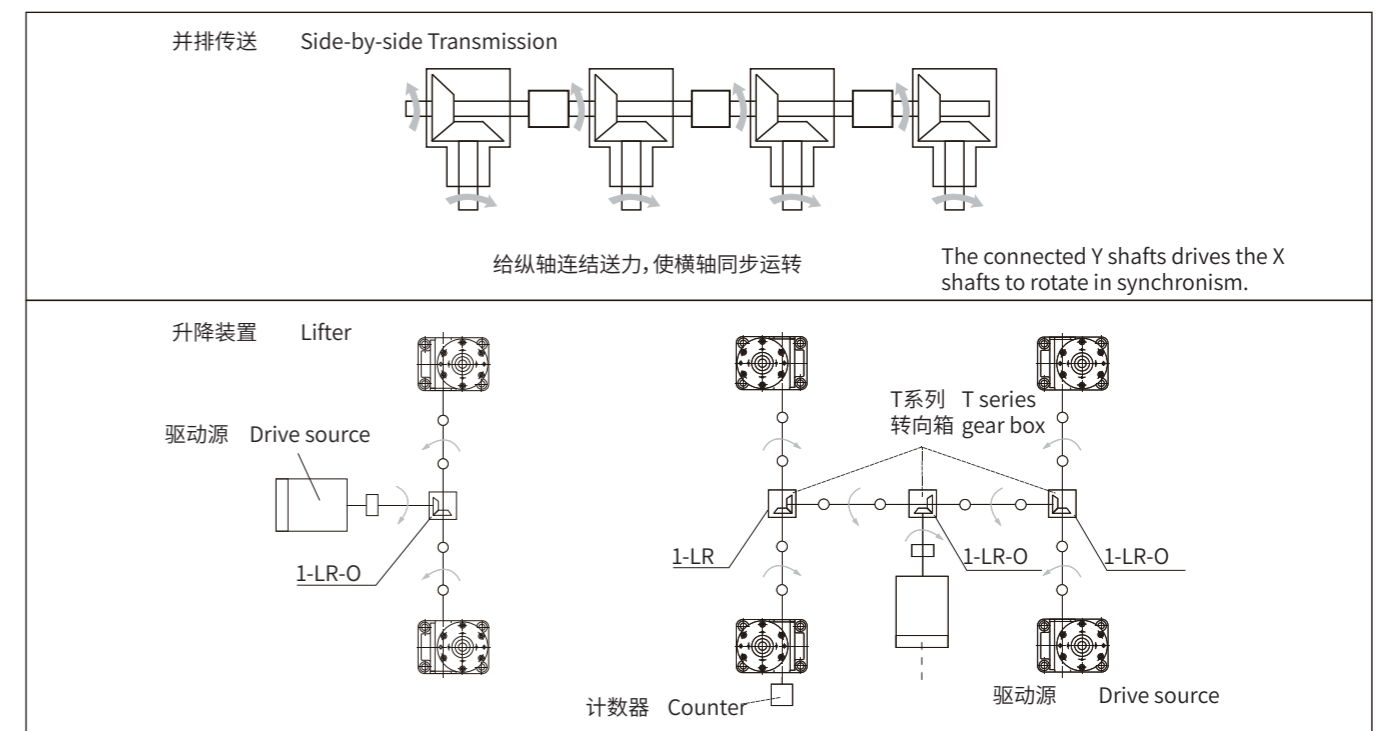

6 被驱动设备系数 f1

6 Driven Machine Factor(f1)

负荷性质 Load Characteristic	每天使用时间(小时) Operating hours per day (h)		
	≤2	2~10	10~24
均匀负载 Uniform	1.00(1.00)	1.00(1.25)	1.25(1.50)
一般冲击 Moderate	1.00(1.25)	1.25(1.50)	1.50(1.75)
强烈冲击 Heavy	1.25(1.50)	1.50(1.75)	1.75(2.00)

注:当每小时启动、停止次数在10次以上,请使用括号内数值。

Note: Apply values in the brackets when starts per hour are no less than 10 times.

7 选型举例

7 Examples of Type Selection

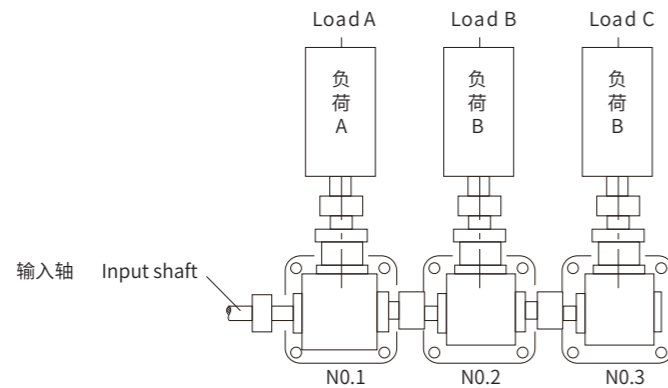

3台负载全部为196N·m,一般冲击,每天连续工作8小时,即使用系数f1=1.25,输入转速以300r/min,速比全部为1。

根据公式:每台齿轮箱本身所需的负载:
 $T2N \geq T2 \times f1 = 196 \times 1.25 = 245N \cdot m$

※1号齿轮箱:

因1号齿轮箱本身的负载为245N·m,而2号、3号齿轮箱需通过1号齿轮箱体传递扭矩。所以1号齿轮箱应承担的负载为:
 $245N \cdot m + 245N \cdot m + 245N \cdot m = 735N \cdot m$,依据传动能力表,应选T12。

※2号齿轮箱:

除本身的负载245N·m,还需传递3号齿轮箱的扭矩。所以总负载应为
 $245N \cdot m + 245N \cdot m = 490N \cdot m$,依据传动能力表,应选T10。

※3号齿轮箱:

由于仅一个负载C进行运转,即所需负载在245N·m以上即可,依据传动能力表可选T8。

注意事项:

1. $i \neq 1$ 时,请确定或告知输入轴;选横轴输入为减速,选纵轴输入为增速,安装方位和尺寸确定了以后,就不能更改两轴的位置。
2. 多台连动输出校对连动轴的承载能力。

Load characteristics of each gear unit: 196N.m, moderate, working 8 hours/d continuously; i.e: driven machine factor $f1=1.25$, input speed=300r/min, ratio $i=1$. Calculated with the following formula, the torque required by each gear unit is $T2N \geq T2 \times f1 = 196 \times 1.25 = 245N \cdot m$

No.1 gear unit:

No.1 gear unit carries its own torque of 245N.m and at the same time transmits torques to No.2 and No.3 gear units, so the total load is: $245N \cdot m + 245N \cdot m + 245N \cdot m = 735N \cdot m$. In the table of Transmission Capacity, T12 is selected.

No.2 gear unit:

Besides its own torque, No.2 gear unit has to transmit torque to No.3 gear unit, so the total load is: $245N \cdot m + 245N \cdot m = 490N \cdot m$. In the table of Transmission Capacity, T10 is selected.

No.3 gear unit:

As only load C exists, torque larger than 245N.m is acceptable. In the table of Transmission Capacity, T8 is selected.

Notes:

1. When $i \neq 1$, please make a choice of the input shaft. When X shaft acts as the input shaft, the machine is a reducer; when Y shaft acts as the input shaft, it is an increaser. The positions of the two shafts cannot be changed once the mounting positions and dimensions are fixed.
2. When several gear units are connected for output, load capacity of the connection shaft should be checked.

8 轴径向力Fr表(N)

8 Radial Force on Shafts (Fr)(N)

i_N	n_1 (r/min)	T4		T6		T7		T8		T10		T12		T16		T20		T25	
		X-shaft	Y-shaft	X-shaft	Y-shaft	X-shaft	Y-shaft	X-shaft	Y-shaft	X-shaft	Y-shaft	X-shaft	Y-shaft	X-shaft	Y-shaft	X-shaft	Y-shaft	X-shaft	Y-shaft
1	1450	833	951	1911	2450	2450	3136	3234	3381	4165	4508	5096	5586	10633	10976				
	960	882	1029	2058	2597	2744	3234	3479	3626	4459	4851	5488	6076	11368	11760	15386	15608		
	730	960	1127	2205	2842	2989	3381	3773	3969	4851	5292	5880	6566	12446	12740	16660	17150	24794	25480
	580	1078	1323	2499	3185	3381	3822	4263	4459	5488	5880	6713	7301	14014	14504	18816	19404	28028	28910
	480	1372	1715	3185	3528	4018	4900	4851	5978	6272	7056	7742	8134	15680	16170	21070	21756	31360	32340
	360	1519	1960	3430	3528	4410	5537	5243	6958	6713	7987	8232	9065	17150	17640	23422	24108	34300	35280
	240	1911	1960	3430	3528	5096	6272	7889	8820	8575	9604	9261	10290	19600	19894	25970	26754	38612	39788
	100	1911	1960	3430	3528	5096	6272	8428	8820	9996	11760	11368	12593	22540	22540	28420	32928	39200	49000
1.5	1450	1078	1960	2548	2842	3430	5390	4361	7987	5194	9212	5978	10486	5978	12152	7693	14602		
	960	1078	1960	3038	3087	4067	5978	5096	8820	6174	10486	7252	12152	6419	13083	8771	17934	12985	24647
	730	1078	1960	3430	3332	4753	6076	6076	8820	7448	11760	8869	14504	6958	14210	9506	19453	13573	29400
	580	1078	1960	3430	3528	5096	6174	7644	8820	9555	11760	11466	14504	7840	16072	10780	22001	15680	33222
	480	1078	1960	3430	3528	5096	6272	8428	8820	9996	11760	11858	14504	8820	17934	12005	24598	17542	37142
	360	1078	1960	3430	3528	5096	6272	8428	8820	9996	11760	11858	14504	9604	19600	13132	27342	19159	40474
	240	1078	1960	3430	3528	5096	6272	8428	8820	9996	11760	11858	14504	10829	22148	14798	30282	21658	45766
	100	1078	1960	3430	3528	5096	6272	8428	8820	9996	11760	11858	14504	13328	22540	18228	33320	26656	49000
3	1450	1078	1960	3430	3528	5096	6272	8428	8820	9996	11760	11858	14504	22540	22540	28420	33320	39200	49000
	960	1078	1960	3430	3528	5096	6272	8428	8820	9996	11760	11858	14504	22540	22540	28420	33320	39200	49000
	730	1078	1960	3430	3528	5096	6272	8428	8820	9996	11760	11858	14504	22540	22540	28420	33320	39200	49000
	580	1078	1960	3430	3528	5096	6272	8428	8820	9996	11760	11858	14504	22540	22540	28420	33320	39200	49000
	480	1078	1960	3430	3528	5096	6272	8428	8820	9996	11760	11858	14504	22540	22540	28420	33320	39200	49000
	360	1078	1960	3430	3528	5096	6272	8428	8820	9996	11760	11858	14504	22540	22540	28420	33320	39200	49000
	240	1078	1960	3430	3528	5096	6272	8428	8820	9996	11760	11858	14504	22540	22540	28420	33320	39200	49000
	100	1078	1960	3430	3528	5096	6272	8428	8820	9996	11760	11858	14504	22540	22540	28420	33320	39200	49000

备注:各规格更低的输出转速按以上最大的Fr值。

Note: For lower output speed, apply the largest Fr2 value in each type.

9 传动能力表

9 Transmission Capacity

i	n ₁ r/min	ARA1		ARA2		ARA4		T4		T6		T7	
		T _{2N} (N·m)	P _{1N} (kw)	T _{2N} (N·m)	P _{1N} (kw)	T _{2N} (N·m)	P _{1N} (kw)	T _{2N} (N·m)	P _{1N} (kw)	T _{2N} (N·m)	P _{1N} (kw)	T _{2N} (N·m)	P _{1N} (kw)
1	1450	7.15	1.108	12.25	1.92	31.9	4.94	31.9	4.94	96	14.90	142	22.00
	960	7.15	0.733	14.3	1.48	35.2	3.61	36.0	3.69	108	11.08	152	15.59
	730	7.15	0.558	16.5	1.3	39.5	3.08	38.0	2.96	115	8.97	170	13.26
	580	7.15	0.443	17.74	1.11	39.5	2.45	39.5	2.45	119	7.37	184	11.40
	480	7.15	0.367	17.74	0.92	39.5	2.03	40.1	2.06	122	6.26	192	9.85
	360	7.15	0.275	17.74	0.69	39.5	1.52	40.5	1.56	125	4.81	197	7.58
	240	7.15	0.183	17.74	0.46	41.2	1.06	41.0	1.05	124	3.18	200	5.13
	100	7.15	0.076	17.74	0.19	41.2	0.44	41.9	0.45	127	1.36	206	2.20
	10	7.15	0.008	17.74	0.02	41.2	0.04	43.0	0.05	132	0.14	214	0.23
1.5	1450									117	12.08	145	14.98
	960									122	8.34	148	10.12
	730									123	6.40	150	7.80
	580									126	5.21	153	6.32
	480									127	4.34	155	5.30
	360									128	3.28	156	4.00
	240									130	2.22	160	2.74
	100									134	0.95	163	1.16
	10									139	0.10	169	0.12
2	1450									102	7.90	137	10.61
	960									105	5.39	140	7.18
	730									106	4.13	142	5.54
	580									108	3.35	144	4.46
	480									109	2.80	146	3.74
	360									110	2.12	147	2.83
	240									111	1.42	149	1.91
	100									114	0.61	152	0.81
	10									116	0.06	157	0.08
3	1450									93.6	4.83	105	5.42
	960									95.1	3.25	107	3.66
	730									96.2	2.50	108	2.81
	580									97.6	2.02	109	2.25
	480									99.3	1.70	110	1.88
	360									100	1.28	111	1.42
	240									100	0.85	113	0.97
	100									102	0.36	115	0.41
	10									104	0.04	118	0.04

1、横轴转速未达到10r/min时, 请使用10r/min的数据。

1. Apply 10r/min when speed of X-shaft is less than 10r/min.

T8	T10	T12	T16	T20	T25	n ₁ r/min	i						
								T _{2N} (N·m)	P _{1N} (kw)	T _{2N} (N·m)	P _{1N} (kw)	T _{2N} (N·m)	P _{1N} (kw)
294	45.55	421	65.23	619	96.00	1019	162.86	\	\	\	\	1450	1
304	31.18	460	47.18	670	68.80	1120	118.51	1842	194.91	\	\	960	
315	24.57	485	37.83	740	57.78	1230	98.97	2050	164.95	3740	302.5	730	
319	19.77	493	30.55	802	49.75	1343	85.86	2274	145.38	3940	253.2	580	
323	16.57	500	25.64	810	41.59	1470	77.77	2330	123.27	4100	218.1	480	
328	12.62	510	19.62	830	31.96	1550	61.50	2590	102.77	4500	179.5	360	
335	8.59	516	13.23	843	21.64	1700	44.97	2900	76.72	4900	130.3	240	
346	3.70	535	5.72	875	9.36	1842	20.30	3205	35.33	5439	60.3	100	
361	0.39	561	0.60	919	0.98	1940	2.14	3205	3.53	5713	6.3	10	
185	19.11	374	38.71	564	58.31							1450	1.5
190	12.99	385	26.38	620	42.44							960	
193	10.04	392	20.43	675	35.14							730	
197	8.14	396	16.39	699	28.91							580	
200	6.84	401	13.74	705	24.13							480	
203	5.21	410	10.54	716	18.38							360	
204	3.49	420	7.19	730	12.49							240	
210	1.50	426	3.04	754	5.38							100	
218	0.16	443	0.32	785	0.56								
180	13.94	305	23.68	516	40.01	921	73.60	1578	126.10			1450	2
185	9.49	309	15.88	516	26.49	940	49.73	1625	85.97	3180	169.1	960	
189	7.37	318	12.43	520	20.30	965	38.82	1670	67.19	3280	132.7	730	
191	5.92	322	10.00	524	16.25	980	31.33	1695	54.18	3332	107.1	580	
192	4.92	325	8.35	530	13.61	990	26.19	1710	45.24	3380	89.9	480	
195	3.75	330	6.36	540	10.40	1000	19.84	1735	34.42	3450	68.8	360	
198	2.54	335	4.30	545	7.00	1115	14.75	1760	23.28	3520	46.8	240	
202	1.08	344	1.84	563	3.01	1058	5.83	1833	10.10	3646	20.2	100	
209	0.11	357	0.19	586	0.31	1098	0.61	1921	1.06	3822	2.1	10	
159	8.21	270	13.97	458	23.65	904	48.21	1529	82.32	2935	158.0	1450	3
161	5.50	276	9.46	465	15.90	930	32.84	1570	55.97	3100	110.5	960	
165	4.29	282	7.35	472	12.27	950	25.51	1620	43.91	3200	86.7	730	
166	3.43	285	5.90	480	9.92	960	20.48	1644	35.41	3246	69.9	580	
167	2.86	287	4.92	485	8.29	970	17.12	1655	29.50	3280	58.5	480	
168	2.15	290	3.73	490	6.28	980	12.98	1685	22.52	3350	44.8	360	
170	1.45	292	2.50	500	4.27	1000	8.83	1720	15.33	3400	30.3	240	
173	0.62	300	1.07	510	1.82	1038	3.82	1777	6.60	3537	13.1	100	
179	0.06	308	0.11	527	0.19	1076	0.40	1865	0.69	3713	1.4	10	

2、以上有黄色标识的规格定货时必须咨询, 横轴输入转速超过1450r/min时, 向本公司咨询。

2. Please consult us when order models with yellow mark or when input speed is more than 1450r/min.

10 轴配置及轴旋转方向的关系、安装方位及尺寸图表

10 Relation between Shaft Arrangement and Direction of Rotation; Mounting Positions and Dimensions:

轴配置形式 Shaft Arrangement Mode			安装方位 Mounting Positions			T4-T16		
1-LR	1-R	1-L	B3	B6	V5			
1-LR-O	1-R-O	1-L-O	B8	B7	V6			
1-UD	1-U	1-D	B3	B6	V5			
1-UD-O	1-U-O	1-D-O	B8	B7	V6			
U-LR	U-R	U-L	B3	B6	V5			
U-LR-O	U-R-O	U-L-O	B8	B7	V6			
D-LR	D-R	D-L	B3	B6	V5			
D-LR-O	D-R-O	D-L-O	B8	B7	V6			
1-1-LR	1-1-R	1-1-L	B3	B6	V5			
1-1-LR-O	1-1-R-O	1-1-L-O	B8	B7	V6			
1-1-UD	1-1-U	1-1-D	B3	B6	V5			
1-1-UD-O	1-1-U-O	1-1-D-O	B8	B7	V6			
U-D-LR	U-D-R	U-D-L	B3	B6	V5			
U-D-LR-O	U-D-R-O	U-D-L-O	B8	B7	V6			

T20-T25		

ARA1-ARA4												
A	56	72	110	155	190	210	235	285	340	390	490	580
A1	40	54	80	125	152	174	195	240	290	330	430	520
b	5	6	8	6	8	10	12	14	14	18	20	22
B	70	98	110	155	190	210	235	285	340	390	410	480
B1	54	76	80	125	152	174	195	240	290	330	110	130
C	8	12	10.5	13	15	19	20	25	28	30	32	35
d	14k6	19k6	24k6	19k6	25k6	32k6	40k6	45k6	50k6	60m6	70m6	85m6
D	42H7	42H7	62H7	100	128	142	170	195	215	215	270	270
D1	/	/	/	100	128	142	170	195	230	270	320	390
E	38	50	60	38	50	62	75	90	100	105	105	130
f	5	5	5	5	5	5	5	5	5	7	10	10
f1	/	/	/	2	11	13	13	10	1	6	0	0
G	155.5	226	265	360	444	530	616	720	830	910	1090	1324
G1	120.5	177	210	180	222	265	308	360	415	455	545	660
G2	/	/	/	53.5	81	88	110.5	120	130	150	195	235
G3	/	/	/	117.5	146	178	210.5	240	270	290	330	400
G4	/	/	/	2	17	13	18	10	0	10	10	10
h	/	/	/	76	90	100	115	140	175	200	245	290
h1	/	/	/	76	87	97	114.5	133	160	186	217	255
L	60	76	110	/	/	/	/	/	/	/	/	/
M2	/	/	/	155H8	190H8	220H8	250H8	305H8	370H8	420H8	360H8	430H8
n	/	/	/	4	4	4	4	4	4	4	8	8
Q1	108	152	160	156	214	226	266	300	350	420	510	600
s	6.8	9	10.8	9	13.5	13.5	13.5	17.5	22	26	22	26
t	16	21.5	27	21.5	28	35	43	48.5	53.5	64	74.5	90
w	24	38	40	/	/	/	/	/	/	/	/	/
Wt. (kg)	1.5	3.3	5.3	10	21	32	49	78	124	188	297	488

11 附件
润滑油

11 Accessories
Oil

		油量表						Oil level (L)					
Type		ARA1	ARA2	ARA4	T4	T6	T7	T8	T10	T12	T16	T20	T25
V		Filled	Filled	Filled	Filled	0.95	1.5	1.9	3.5	7	10	11	18

注:在环境温度-10°C~+40°C时,
(1) ARA1/ARA2/ARA4/T4系列润滑油
为000#锂基脂;
(2) T6-T16系列润滑油牌号为
VG220(ISO粘度等级), 附件代号V22;
(3) T20-T25系列润滑油牌号为
VG320(ISO粘度等级), 附件代号V32。

Note: When ambient temperature is -10°C+40°C,
(1) ARA1\ARA2\ARA4\T4 series lubricant is
000#lithium grease;
(2) T6-T16 Series lubricant brand is VG220(I-
SO viscosity class), accessory code is V22;
(3) T20-T25 Series lubricant brand is VG320(I-
SO viscosity class), accessory code is V32.

12 应用举例

12 Application Exmaples:

升降装置 Lifter

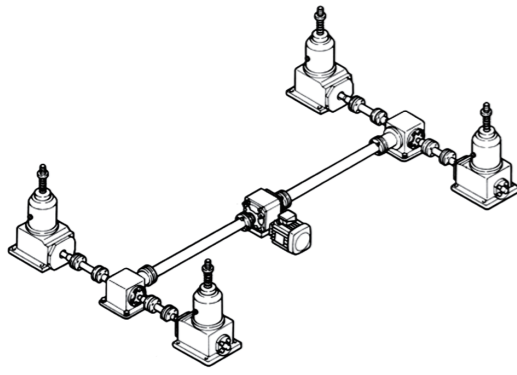

1台减速机左右输出,通过转向,同时升降。
As the gear unit outputs on both sides, after shifting directions, it can lift things at the same time.

立体车库 Stereo Garage

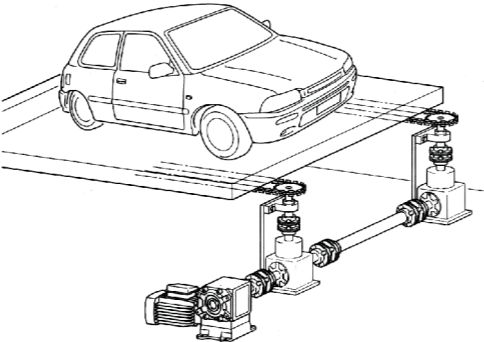

1台减速机驱动左右链轮同步运转。
One gear unit drives both chain pulleys to roll at the same speed.

游戏机 Amusement

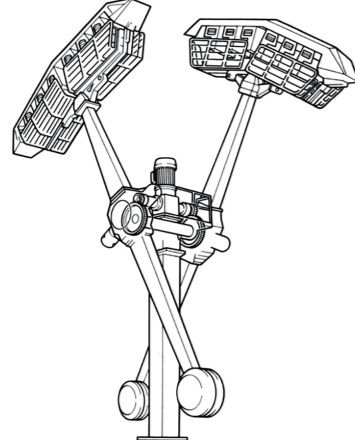

纵横输入,2横轴相反运转
Input on Y-shaft, two X-shafts run in reverse directions.

包装机 Packer

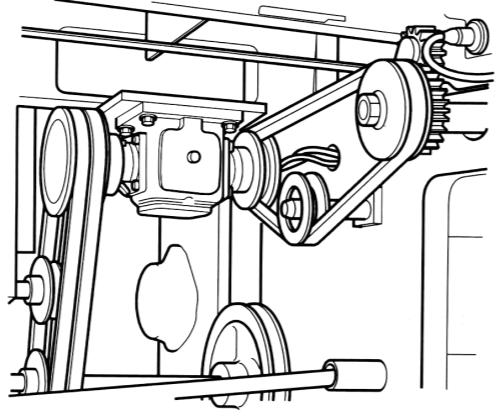

13 轴端中心孔

13 Screw hole in shaft end

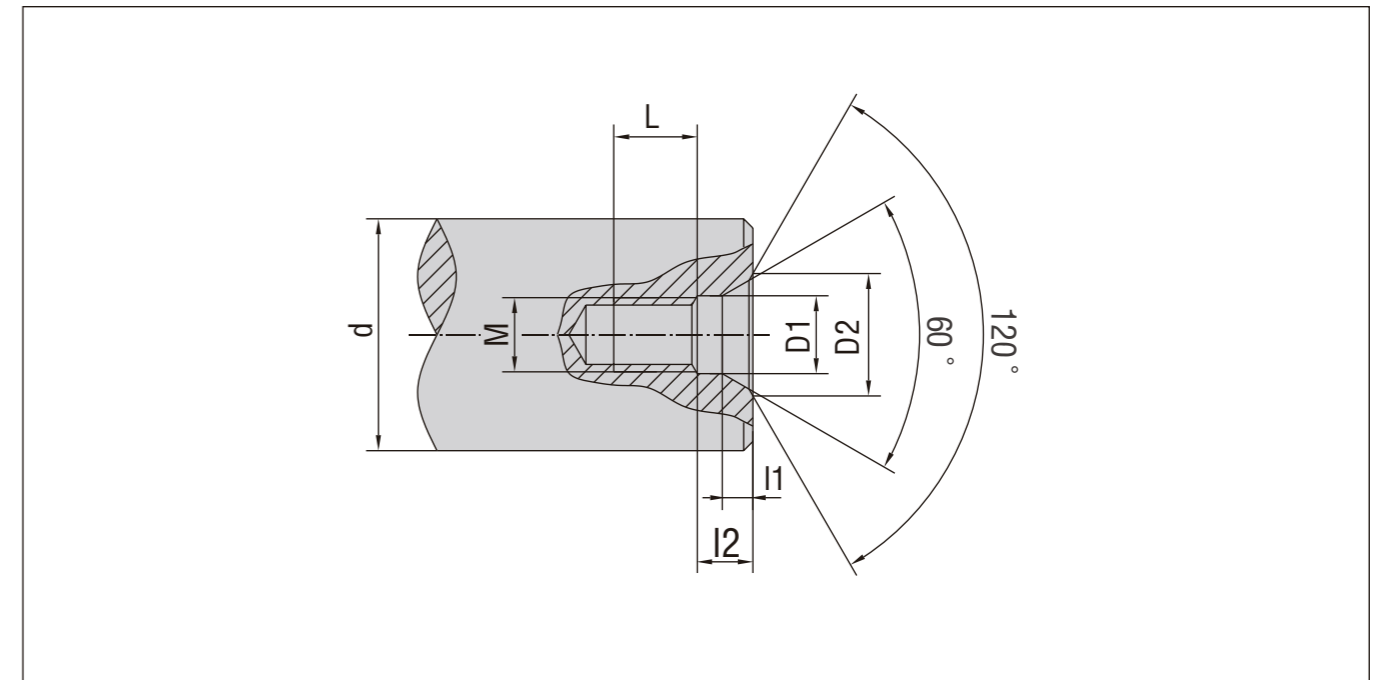

d	M	L	l2	l1	D1	D2
7<d≤10	M3	10	2.6	1.8	3.2	5.8
10<d≤13	M4	10	3.2	2.1	4.3	7.4
13<d≤16	M5	10	4	2.4	5.3	8.8
16<d≤21	M6	12	5	2.8	6.4	10.5
21<d≤24	M8	12	6	3.3	8.4	13.2
24<d≤30	M10	15	7.5	3.8	10.5	16.3
30<d≤38	M12	20	9.5	4.4	13	19.8
38<d≤50	M16	25	12	5.2	17	25.3
50<d≤85	M20	30	15	6.4	21	31.3
85<d≤130	M24	35	18	8	25	38
130<d≤225	M30	45	18	11	31	48

注: d>255时, 轴端取双螺纹孔。

Note: If d>255, double screw hole in shaft end is taken.

14 平键与键槽的尺寸 14 Parallel keys and keyway

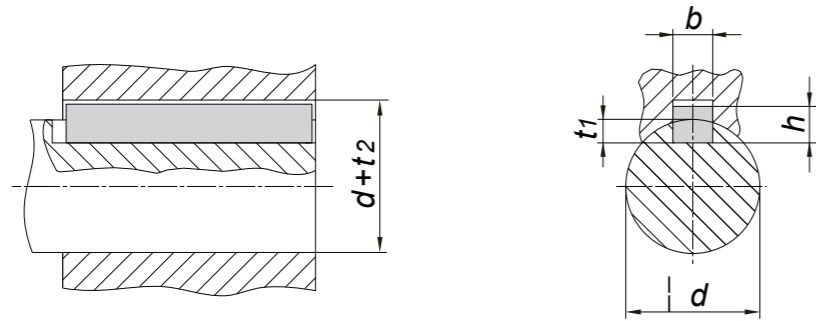

d	b	h	t ₁	d+t ₂
8<d≤10	3	3	1.8	d+1.4
10<d≤12	4	4	2.5	d+1.8
12<d≤17	5	5	3	d+2.3
17<d≤22	6	6	3.5	d+2.8
22<d≤30	8	7	4	d+3.3
30<d≤38	10	8	5	d+3.3
38<d≤44	12	8	5	d+3.3
44<d≤50	14	9	5.5	d+3.8
50<d≤58	16	10	6	d+4.3
58<d≤65	18	11	7	d+4.4
65<d≤75	20	12	7.5	d+4.9
75<d≤85	22	14	9	d+5.4
85<d≤95	25	14	9	d+5.4
95<d≤110	28	16	10	d+6.4
110<d≤130	32	18	11	d+7.4
130<d≤150	36	20	12	d+8.4
150<d≤170	40	22	13	d+9.4
170<d≤200	45	25	15	d+10.4
200<d≤230	50	28	17	d+11.4
230<d≤260	56	32	20	d+12.4

随着技术迭代进步，博能产品样本将会同步更新，请见谅。
 Along with the technology advancedet.,the product of the manual of Boneng will be changed,please forgive.

博能产品集成图

Boneng Product Integration Diagram

CONTROL
控制层

DRIVE
驱动层

MOTOR
马达层

GEAR
齿轮层

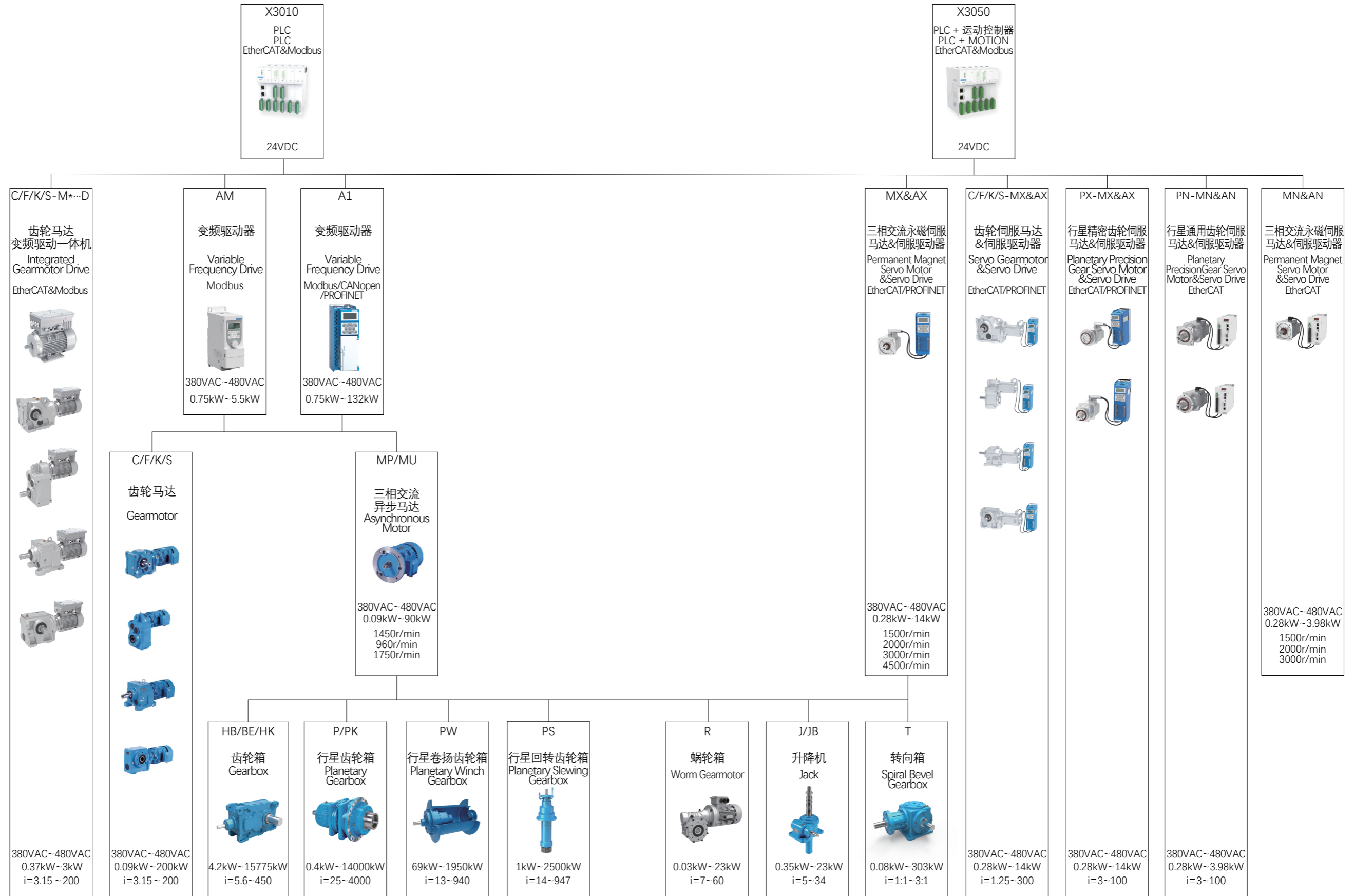

博能传动(沈阳)有限公司	BONENG TRANSMISSION(SHENYANG)CO.,LTD.
沈阳市沈北新区 太平洋工业城A区A73-6号 电话: 024-31271571	No. A73-6, Area A, Pacific Industrial City, Shenbei New District, Shenyang, Liaoning Province, China TEL: 024-31271571

博能传动(天津)有限公司	BONENG TRANSMISSION(TIANJIN)CO.,LTD.
天津市北辰区双海道6号 宏鹏工业园7号车间 电话: 022-26929556	7th Workshop, Hongpeng Industrial Park, No. 6 Shuanghai Road, Beichen District, Tianjin City,China TEL: 022-26929556

博能传动(潍坊)有限公司	BONENG TRANSMISSION(WEIFANG)CO.,LTD.
山东省潍坊市安丘市经济开发区 汶水路与昆仑大街交叉口往北 100米路东1号车间 电话: 0536-2141166	1st Workshop, Economic Development Zone, Anqiu, Weifang City, Shandong Province, China TEL: 0536-2141166

博能传动(开封)有限公司	BONENG TRANSMISSION(KAIFENG)CO.,LTD.
河南省开封市宋城路四大街11号 海神机械院内五号厂房 电话: 0371-23335238	5th Workshop, Haishen Machinery, No.11, Fourth Street, Songcheng Road,New District, Kaifeng City, Henan Province, China TEL: 0371-23335238

博能传动(长沙)有限公司	BONENG TRANSMISSION(CHANGSHA)CO.,LTD.
湖南省长沙市望城经济开发区 普瑞大道1288号 电话: 0731-88386958	No. 1288 Puri Avenue, Wangcheng Economic Development Zone, Changsha City, Hunan Province, China TEL: 0731-88386958

博能传动(苏州)有限公司	BONENG TRANSMISSION(SUZHOU)CO.,LTD.
江苏省苏州市相城区如元路100号 电话: 0512-66189662	No. 100, Ruyuan Road, Xiangcheng District, Suzhou, Jiangsu Province, China TEL: 0512-66189662

博能传动(美国)有限公司	BONENG TRANSMISSION(USA)LLC.
1250 E 222nd Euclid, OH 44117, United Staes TEL: 1-216-618-3099 TEL: 1-216-618-0138	1250 E 222nd Euclid, OH 44117, United Staes TEL: 1-216-618-3099 TEL: 1-216-618-0138

博能传动(印度)有限公司	BONENG TRANSMISSION(INDIA)PVT.LTD
Plot No. E-10/3, MIDC sinnar (Malegaon) Industrial Area, Nashik, 422123, Maharashtra, India. TEL:+91-11- 4507 6293 (DELHI) TEL:+91-22-2781 3385 (MUMBAI)	Plot No. E-10/3, MIDC sinnar (Malegaon) Industrial Area, Nashik, 422123, Maharashtra, India. TEL:+91-11- 4507 6293 (DELHI) TEL:+91-22-2781 3385 (MUMBAI)